

PARTS MANUAL

BALE KING

AVENGER 2880



BRIDGEVIEW

MANUFACTURED BY: BRIDGEVIEW MANUFACTURING INC.
P.O. BOX 4
GERALD, SASK. CANADA
S0A 1B0
PHONE: (306) 745-2711
FAX: (306) 745-3364

TABLE OF CONTENTS

BALE KING AVENGER 2880

EXTERNAL PARTS AND CONTROLS.....	1 - 3
HUB ASSEMBLY.....	4
PTO ASSEMBLY.....	5 - 8
INNER TUB PARTS.....	9 - 11
HYDRAULIC ASSEMBLIES.....	12
HYDRAULIC SCHEMATICS.....	13

EXTERNAL PARTS AND CONTROLS

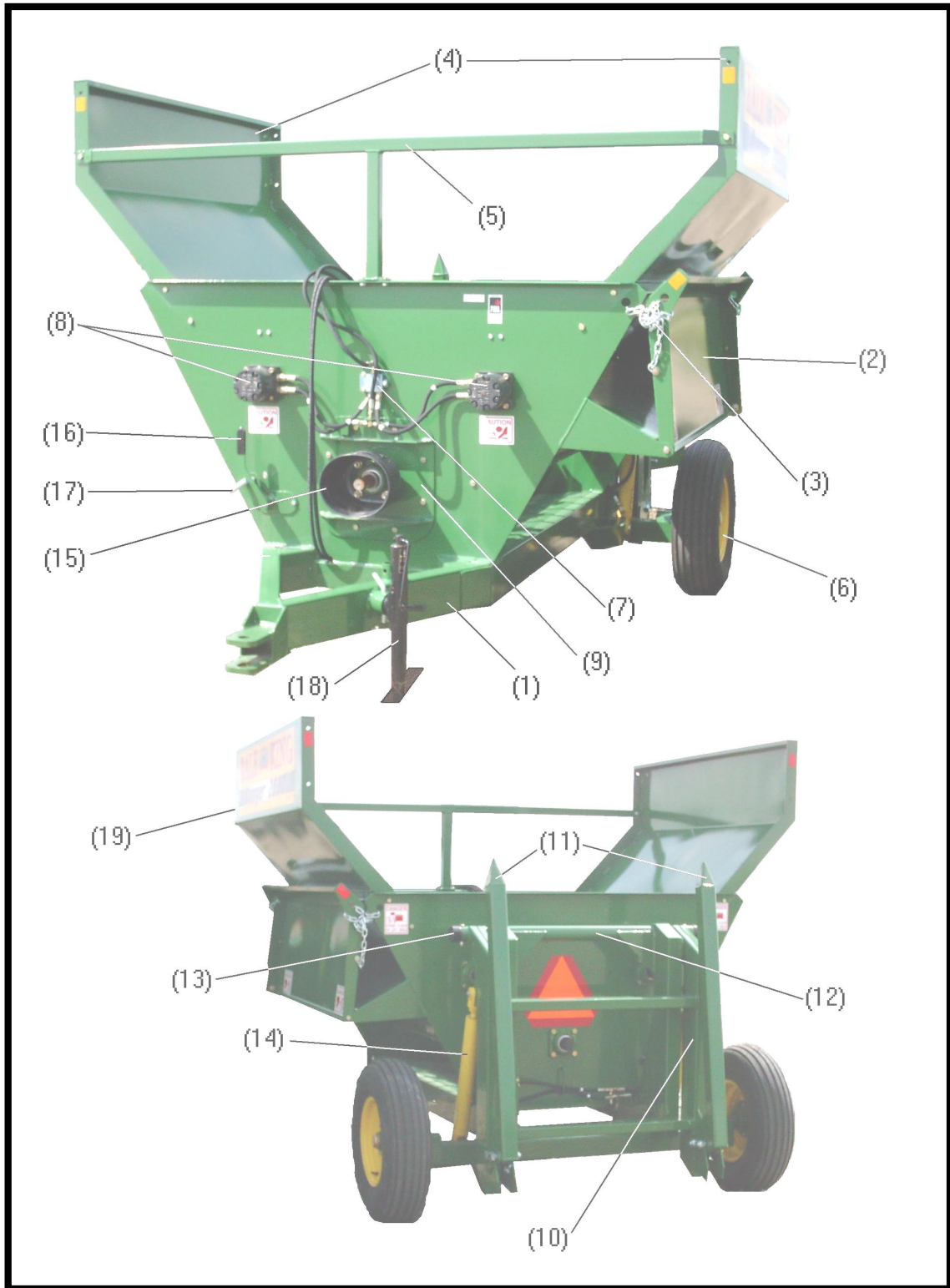

EXTERNAL PARTS AND CONTROLS

PARTS LIST

<u>Ref#</u>	<u>BMI#</u>	<u>Description</u>	<u>Qty.</u>
GREEN/YELLOW			
1	16626	Frame/Tub Assembly	1
2	16632	Deflector	1
3	14636	Plated Chain	2
Not Shown	14461	1/2" x 1 1/2" NC Bolt	2
Not Shown	14443	1/2" NC Locknut	2
Not Shown	13790	1/2" Flat Washer	2
Not Shown	13768	3/8" x 1 1/4" NC Bolt	2
Not Shown	13802	3/8" NC Locknut	2
Not Shown	13772	3/8" Flat Washer	2
Not Shown	10239	Main Deflector Bushing	2
4	16628	Top Rack	2
Not Shown	14460	1/2" x 1" NC Bolt	8
Not Shown	10278	1/2" NC Serrated Flange Nut	8
Not Shown	10807	3/8" x 3/4" Fin Bolt	8
Not Shown	11818	3/8" NC Serrated Flange Nut	8
5	16629	Front Rack	1
Not Shown	14460	1/2" x 1" NC Bolt	4
Not Shown	10278	1/2" NC Serrated Flange Nut	4
6	14396	9.5L-15, 8 Ply Implement Tire and Rim	2
Not Shown	10077	11L-15 Tire (Optional)	2
Not Shown	10287	8" x 15" 6 Bolt Rim (Yellow)	2
7	11742	Flow Divider/Combiner (See Page 13)	1
Not Shown	13761	1/4" x 2" NC Bolt	2
Not Shown	15402	1/4" NC Locknut	2
Not Shown	13763	1/4" Flat Washer	2
8	10045	Hydraulic Beater Motors (See Page 9)	2
9	16631	Rotor Plate	1
Not Shown	14460	1/2" x 1" NC Bolt	8
Not Shown	10278	1/2" NC Serrated Flange Nut	8
Not Shown	16625 17589	PTO and Hose Support	1
10	16627	Fork Frame	1
11	16630	Fork Tines	2
12	16624	Pivot Pipe	1
Not Shown	15397	1/2" x 3 3/4" NC Bolt	1
Not Shown	14443	1/2" NC Locknut	1
Not Shown	10280	1/4" Grease Zerk	2
13	10504	End Cap	2
Not Shown	10580	1/4" x 2" Cotter Pin	8
Not Shown	15431	1" x 5" NC Bolt	4

Not Shown	15436	1" NC Locknut	4
Not Shown	16638	Hose Clip, PTO holder	1
Not Shown	16641	Hose Clip, Frame	1
Not Shown	13802	3/8" NC Locknut	2
14		Fork Hydraulic (See Pages 12 - 13)	
Not Shown	10339	Butt End Cylinder Pin	2
Not Shown	10341	Ram End Cylinder Pin	2
Not Shown	16640	Cylinder Safety Lock	1
Not Shown	12050	PTO Clip, Safety Lock	1
15	14539	Plastic PTO Shield	1
16	10297	Rubber Handle Grip	1
17	11784	Plated S-Handle	1
Not Shown	10301	Compression Spring	1
Not Shown	10302	3/16" x 1 1/4" Roll Pin	1
18	14408	Telescoping Jack	1
Not Shown	11785	Jack Pin (w/ hairpin)	1
Not Shown		PTO (See Pages 5 – 8)	
19		Avenger Decal Kit	1
Not Shown		Safety Decals:	
	12229	Danger Sign (Lift Area)	2
	12230	Danger Sign	4
	12219	Caution Sign	2
	12228	SMV	1
	13324	1 1/2" x 3" Amber Reflective Decal	3
	13325	1 1/2" x 3" Red Reflective Decal	3

HUB ASSEMBLY

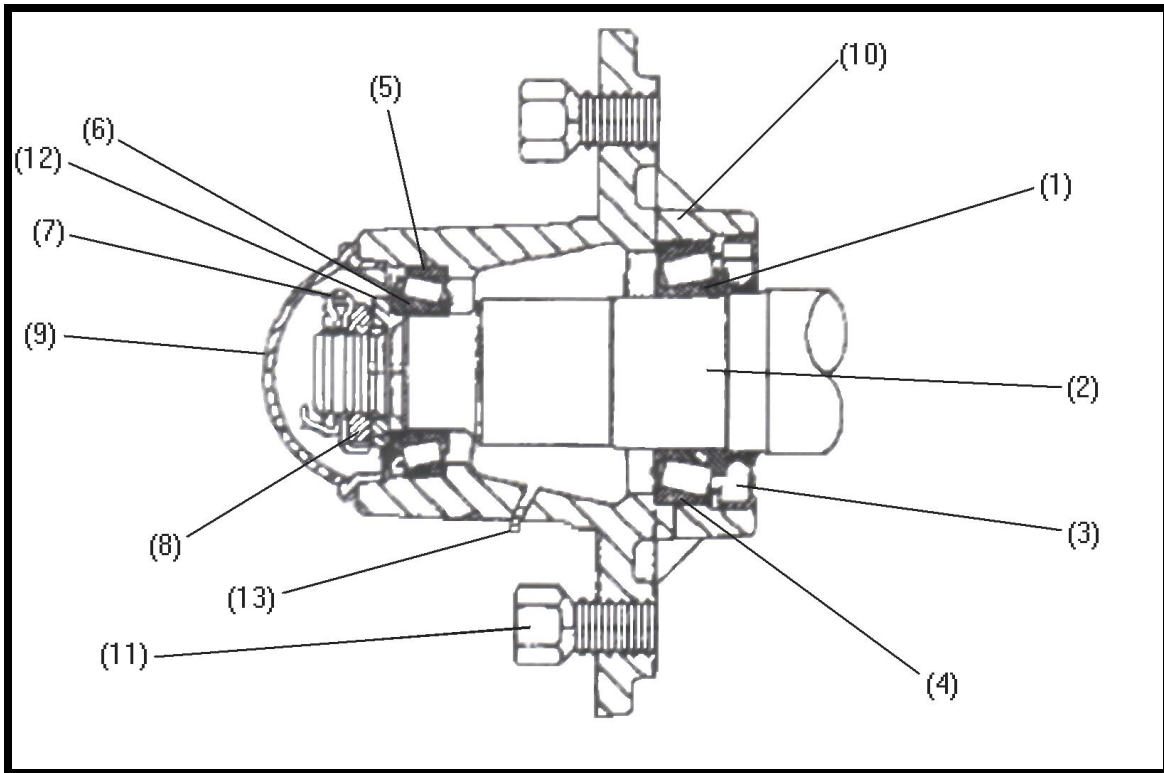

**NOTE: Axle Repair Kit on Next Page
HUB ASSEMBLY**

PARTS LIST

<u>Ref#</u>	<u>BMI#</u>	<u>Description</u>	<u>Qty.</u>
1	10067	Inside Cone	2
2	10065	Spindle w/nut	2
3	10066	Dirt Seal	2
4	10068	Inside Cup	2
5	10070	Outside Cup	2
6	10069	Outside Cone	2
7	10072	3/16" x 1 1/2" Cotter Pin	2
8	10153	Castle Nut	2
9	10073	Dust Cap	2
10	10074	Hub w/Grease Zerk	2
11	10075	Wheel Stud	12
12	10071	Washer	2
13	10280	1/4" Grease Zerk	2

Axle Repair Kit

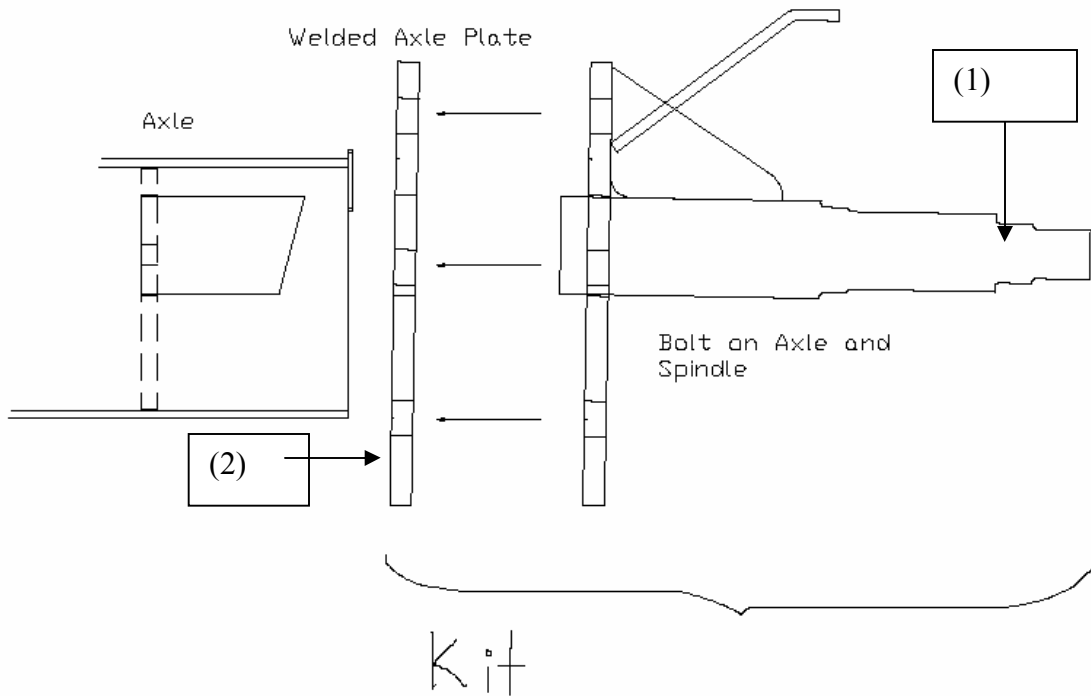

Axle Repair Kit

PARTS LIST

<u>Ref#</u>	<u>BMI#</u>	<u>Description</u>	<u>Qty.</u>
Kit	17647	Axle repair kit spindle	1
1	17648	spindle assembly	1
2	N/A	weldment plate	1
Not Shown	17665	Gusset	1
Not Shown	13800	bolt $\frac{3}{4}$ x 2 NC	6
Not Shown	12455	Nut $\frac{3}{4}$ NC	6
Not Shown	13795	Lock Washer $\frac{3}{4}$	6

PTO ASSEMBLY (BONDIOLI)

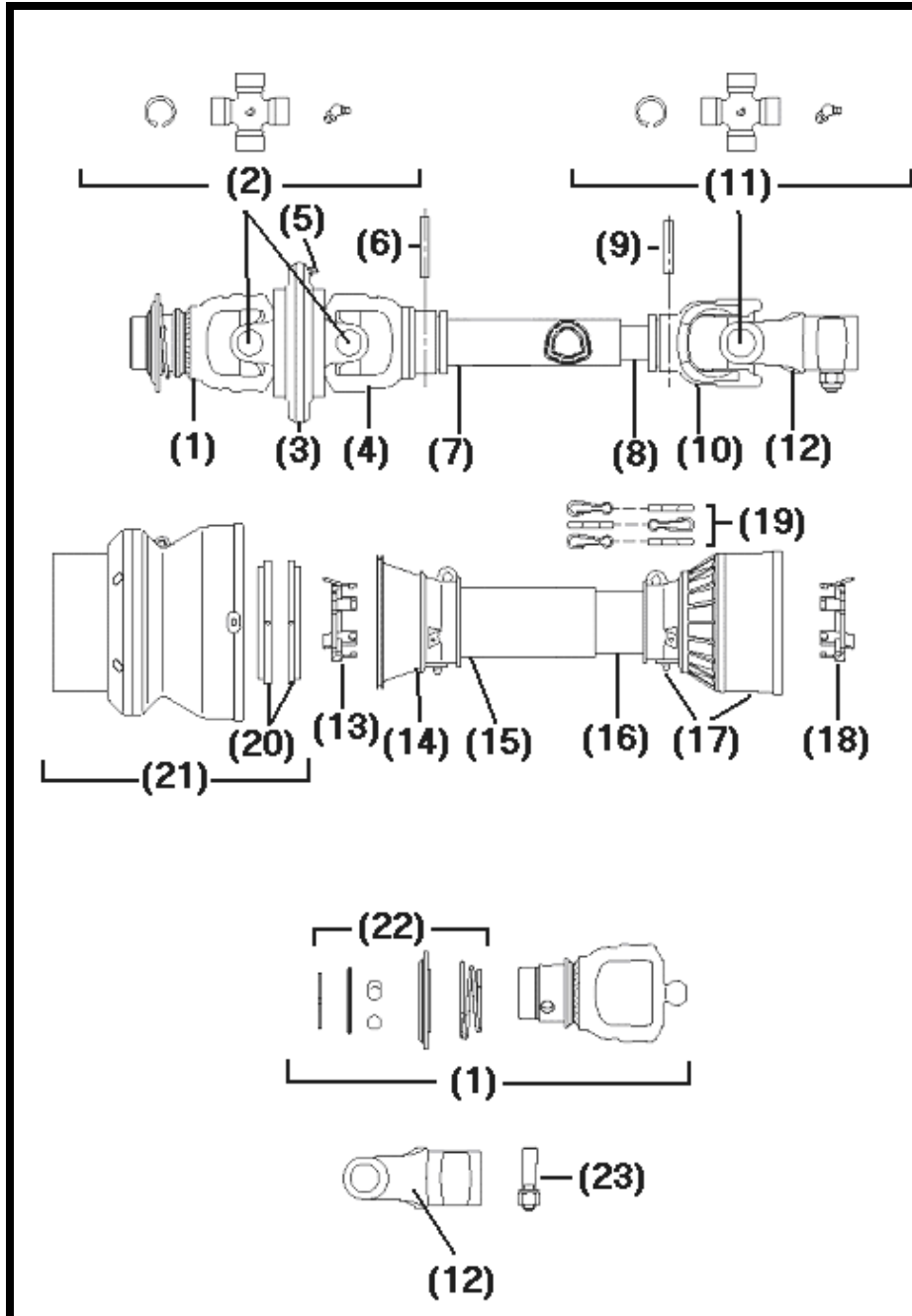

PTO ASSEMBLY (BONDIOLI)

PARTS LIST

<u>Ref#</u>	<u>BMI#</u>	<u>Description</u>	<u>Qty.</u>
	GREEN/YELLOW		
	14540	Complete PTO Assembly	
1	16041	Yoke 1 3/8" 21 Spline	1
2	16042	U-Joint Cross Kit	2
3	16043	Central Body CV Joint	1
4	16044	Yoke	1
5	10121	Grease Zerk	1
6	16046	Roll Pin	1
7	16047	Cardan Tube Outer	1
8	16048	Cardan Tube Inner	1
9	16049	Roll Pin	1
10	16050	Inner Tube Yoke	1
11	16051	U-Joint Cross Kit	1
12	16052	Yoke	1
13	16053	Bearing Shield	1
14	16054	Safety Cone	1
15	16055	Safety Tube Outer	1
16	16056	Safety Tube Inner	1
17	16057	I Cone Shield Cones	1
18	16058	Shield Bearing	1
19	10419	Shield Chain	3
20	16059	CV Shield Bearing	1
21	16060	CV Shield W / Bearing	1
22	16061	Ball Collar Kit	1
23	16062	Pin	1

NOTE:

Bondioli: Identified by *Cone Shaped* Shield on machine end

PTO ASSEMBLY (WALTERSCHEID) 2380 SERIES

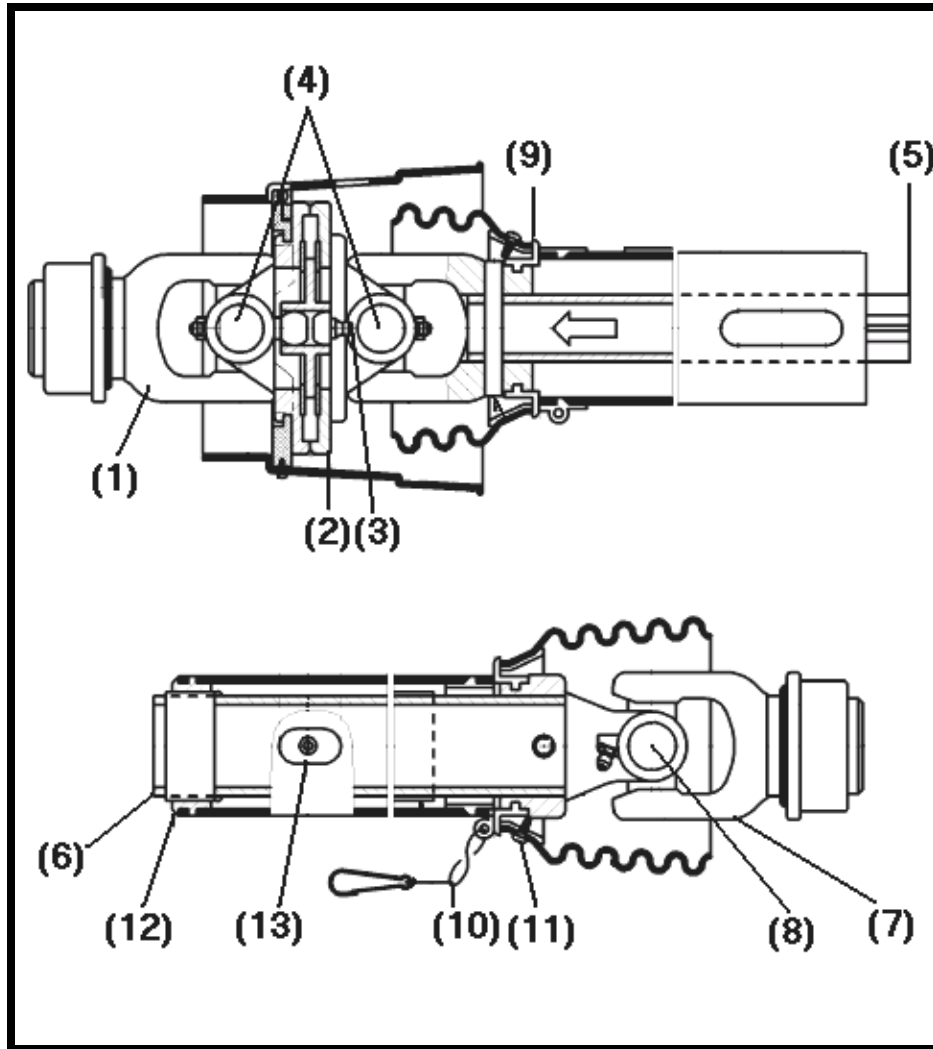

PTO ASSEMBLY (WALTERSCHEID)

PARTS LIST

<u>Ref#</u>	<u>BMI#</u>	<u>Description</u>	<u>Qty.</u>
	15598	Complete PTO Assembly	
1	15990	Yoke 1 3/8" - 21 SPL. ASG	1
2	15992	Double Yoke	1
3	10089	Zerk - In Item 2	1
4	15991	Cross and Bearing Kit	2
5	15996	Inner Profile 1bGA	1
6	15995	Profile and Sleeve W.A.	1
7	15994	Yoke 1 3/4" - 20 SPL. ASG	1
8	15993	Cross and Bearing Kit	1
9	10099	Bearing and Ring SC25	2
10	10105	Safety Chain	1
11	10108	Screw in Items 15, 16, 17	8
12	10109	Support Bearing	1
13	10110	Zerk - In Item 8	1
Not Shown	10113	ASG Col. Kit - In Item 1	1

NOTE:

Walterscheid: Identified by *Accordian Style* bell shield on machine end of PTO

INNER TUB PARTS

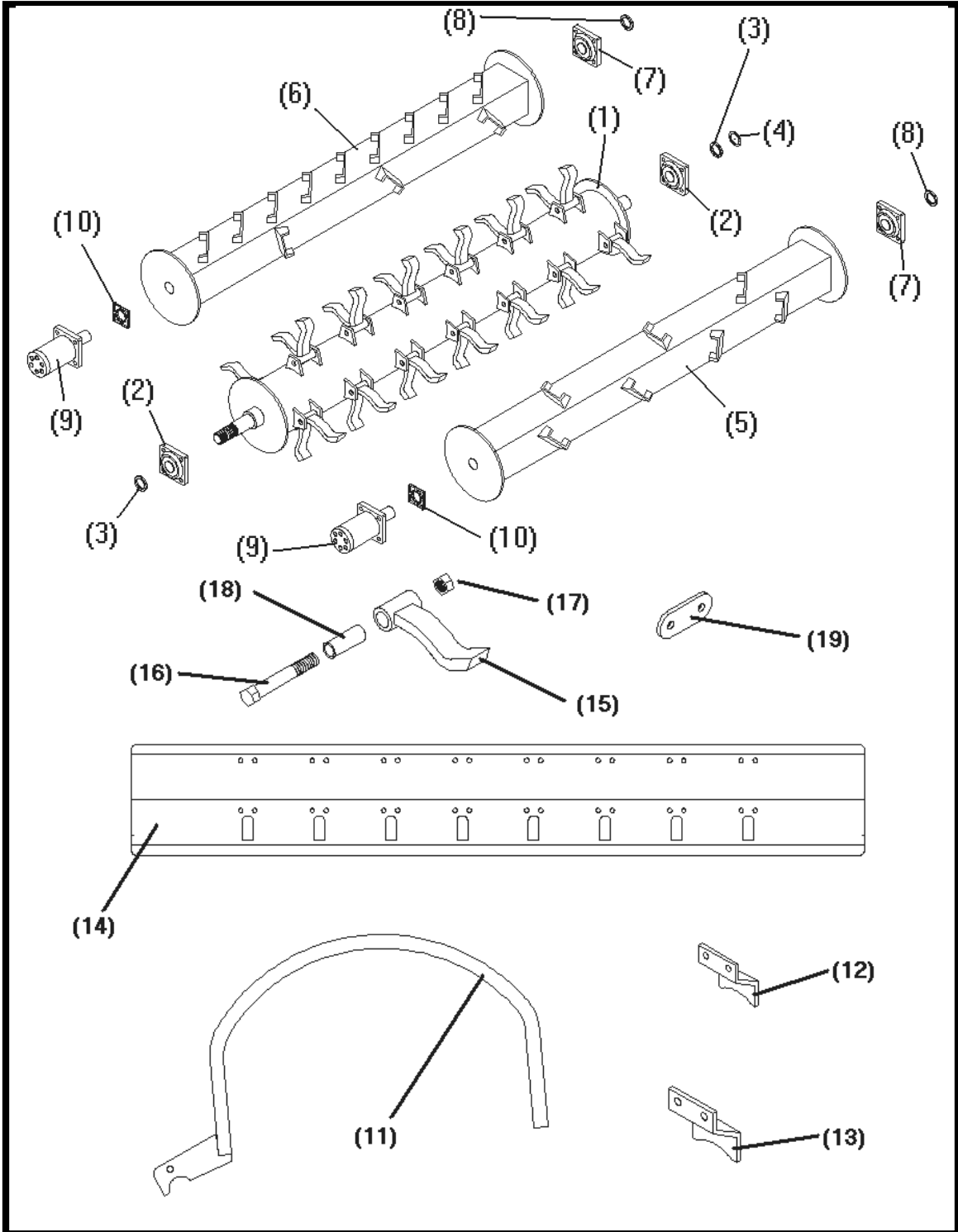

INNER TUB PARTS

PARTS LIST

<u>Ref#</u>	<u>BMI#</u>	<u>Description</u>	<u>Qty.</u>
1	15609	Rotor	1
2	10221	1 15/16" Rotor Bearings	2
3	10268	1 15/16" Lock Collar	2
4	10227	Split Collar (Back of Rotor)	1
Not Shown	14649	5/8" x 2 1/2" NF Gr. 8 Bolt	4
Not Shown	10274	5/8" x 1 3/4" NF Gr. 8 Bolt	4
Not Shown	15599	5/8" NF Gr. 8 Nut	8
Not Shown	15608	5/8" Washer	8
Not Shown	15398	5/8" Flange Locknut	4
Not Shown	10270	1/8" NPT Grease Zerk	2
5	15611	Beater (Discharge Side)	1
6	15804	Beater (Non-Discharge Side)	1
7	10038	1 3/4" Bearings (Beaters)	2
8	10040	1 3/4" Lock Collar	
9	10045	Hydraulic Beater Motors	2
Not Shown	10048	Hydraulic Beater Motor Seal Kit	
Not Shown	10172	1/2" x 2 1/2" NC Socket Head Bolt	8
Not Shown	14461	1/2" x 1 1/2" NC Bolt	8
Not Shown	10183	1/2" High Collar Lock Washer	8
Not Shown	10278	1/2" NC Serrated Flange Nut	16
Not Shown	10270	1/8" NPT Grease Zerk	2
10	10021	Coupler Assembly	
11	15610	Hoop	8
Not Shown	16531	3/8" x 2" NC U-Bolt	16
Not Shown	11818	3/8" NC Serrated Flange Nut	32
12	16639	Twine Guard (Beater)	2
13	16636	Twine Guard (Rotor)	1
Not Shown	13806	3/8" x 1" NC Bolt	10
Not Shown	13768	3/8" x 1 1/4" NC Bolt	2
Not Shown	11818	3/8" NC Serrated Flange Nut	12
Not Shown	15715	Twine Guard Shim (14 Ga.)	Use as Required
Not Shown	15716	Twine Guard Shim (12 Ga.)	Use as Required
14	16633	Charging Panel	1
Not Shown	14461	1/2" x 1 1/2" NC Bolt	2
Not Shown	14443	1/2" NC Locknut	2
Not Shown	16345	1/2" Fender Washer	2
Not Shown	10239	Charging Panel Bushing	2

15	10220 17460	Flails (Replace in Pairs)	18
16	10443	Shoulder Bolt	18
17	10007	3/4" NC Locknut	18
18	10005	Flail Bushing	18
Not Shown	16635	Hoop Adjustment Pivot Pipe	1
Not Shown	13806	3/8" x 1" NC Bolt	2
Not Shown	11818	3/8" NC Serrated Flange Nut	2
Not Shown	16634	Hoop Manifold	1
Not Shown	13806	3/8" x 1" NC Bolt	8
Not Shown	13802	3/8" NC Locknut	8
19	16637	Cam Link	3
Not Shown	10175	1/2" x 1 1/4" NC Bolt	6
Not Shown	14443	1/2" NC Locknut	6

HYDRAULIC CYLINDER (RAM INDUSTRIES)

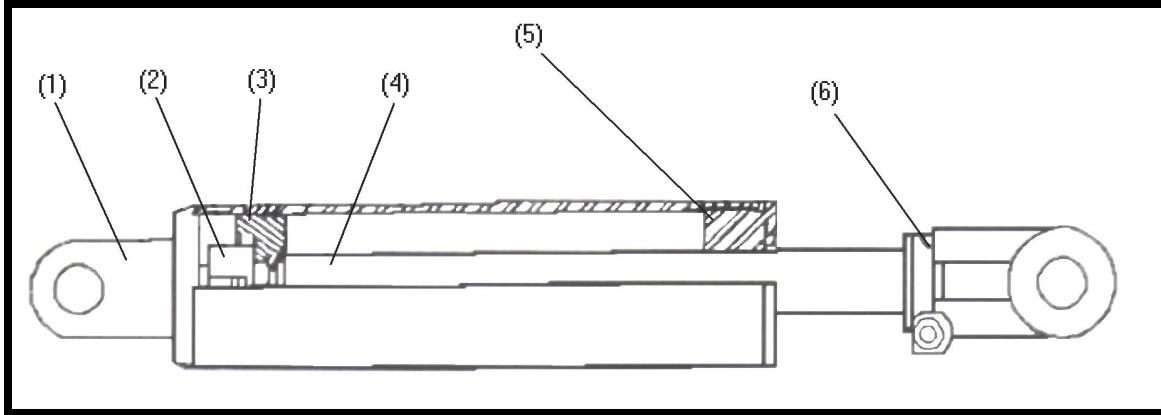

HYDRAULIC CYLINDER (RAM INDUSTRIES)

PARTS LIST

<u>Ref#</u>	<u>BMI#</u>	<u>Description</u>	<u>Qty.</u>
	10517	Hydraulic Cylinder Assembly	
1	10522	Barrel Assembly w/Clevis	1
2	10062	Lock Nut Piston Rod	1
3	10519	Piston 2.5" Dia.	1
4	10058	Cylinder Shaft	1
5	10060	Gland	1
6	10061	Clevis	1
Not Shown	10521	Seal Kit	1

HYDRAULIC SCHEMATICS

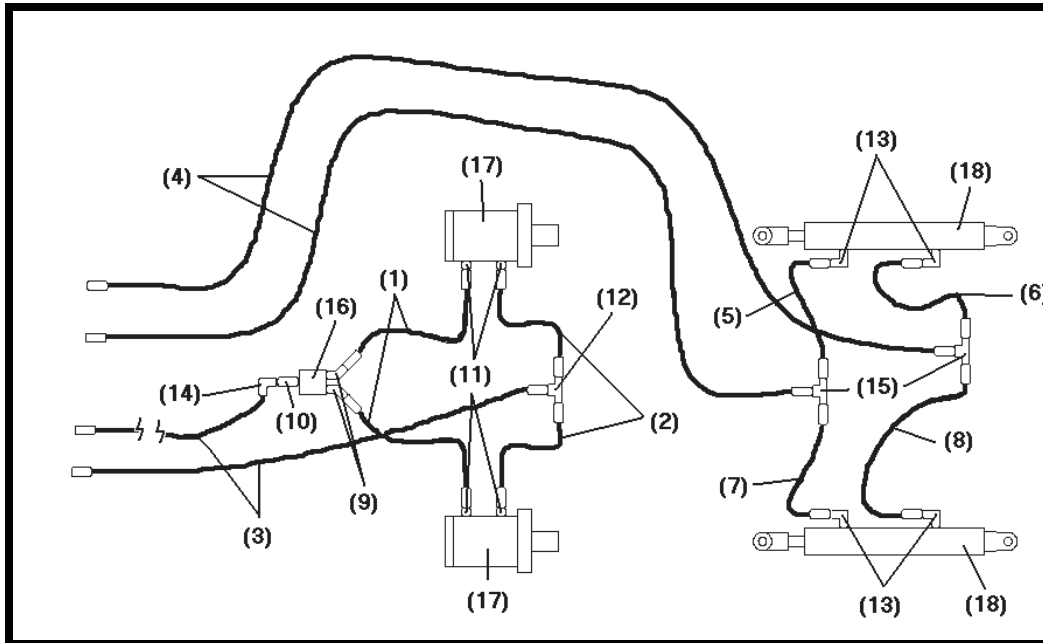

HYDRAULIC SCHEMATICS

PARTS LIST

<u>Ref#</u>	<u>BMI#</u>	<u>Description</u>	<u>Qty.</u>
	GREEN/YELLOW		
1	16663	Hose - 21" OAL 6FJX - 8FJX	2
2	16664	Hose - 18" OAL 6FJX - 8FJX	2
3	16665	Hose - 84" OAL 6FJX - 8MP	2
4	16653	Hose - 182" OAL 6FJX - 8MP	2
5	16654	Hose - 26" OAL 6FJX - 6FJX	1
6	16655	Hose - 12" OAL 6FJX - 6FJX	1
7	16656	Hose - 46" OAL 6FJX - 6FJX	1
8	16657	Hose - 34" OAL 6FJX - 6FJX	1
9	11725	Adapter - 8MP - 6MJ45	2
10	11739	Adapter - 10MB - 6MJ	1
11	10161	Adapter - 10MB - 8MJ	4
12	10188	Adapter - 6MJBH - 6MJT	1
13	10200	Adapter - 8MB - 6MJ90	4
14	12162	Adapter - 6MJ - 6FJX90	1
15	10163	Adapter - 6MJ - 6MJT	2
16	11742	Flow Divider/Combiner	1

17	10045	Hydraulic Beater Motors	2
18		Hydraulic Cylinders (See Page 12)	
19	10167 17379	Pioneer Male Tip	4