



BRIDGEVIEW MFG. INC.



**SHOWN WITH OPTIONAL 3 BALE KIT*

BALE KING 5300

Bale Processor

Operator's & Parts Manual

Last Updated: April 2025



Bridgeview Manufacturing Inc.

P.O. Box 4

Gerald, Saskatchewan, Canada

S0A 1B0

Phone: 1-306-745-2711

Fax: 1-306-745-3364

Email: bmi@sasktel.net

www.bridgeviewmanufacturing.com

Your Authorized Dealer
Your Serial Number

The Serial Number is located the front tub panel, next to the operator manual box.

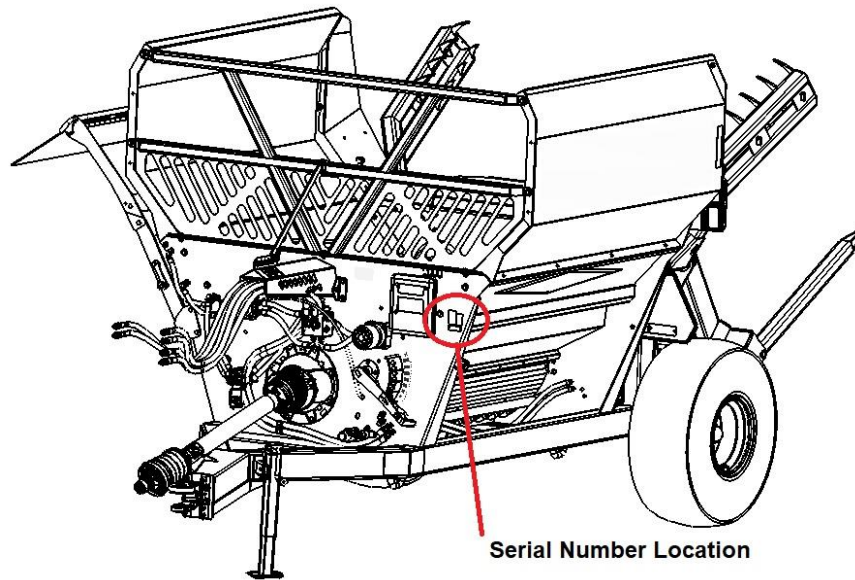

	<p>⚠ WARNING</p> <p>Failure to read and understand operator's manual & all safety signs could result in serious injury. Manual must remain with machine.</p>
---	--

TABLE OF CONTENTS

INTRODUCTION	1
Safety Precautions.....	1
Safety Decals	2
Transportation.....	4
FEATURES & OPERATION.....	6
Power Take-off	6
Hydraulics.....	10
Hose Holder	13
Implement Tongue.....	14
Rear Forks.....	14
Loading Bales	15
Hoop Grate Adjustment	16
Deflector	17
Agitators.....	19
Optional Diverter Kit	20
Optional Fine Chop Kit.....	21
Optional Total Ration Grain Tank (5300TR)	22
Optional 3 Bale Kit (5300X).....	23
Optional Back-up Camera.....	27
SERVICE AND MAINTENANCE.....	28
Greasing Locations	28
Tires	31
Twine Removal.....	32
Gearbox and Flail Replacement Procedure.....	34
Trouble-shooting Guide.....	35
Features and Specifications.....	36
PARTS MANUAL.....	38
HYDRAULIC SCHEMATICS.....	95

INTRODUCTION

Thank you for purchasing a **Bale King** bale processor. With the proper operation and service as outlined in this manual, the Bale King will provide you with years of trouble-free operation.

This is a complete safety, operation and parts manual for the Bale King 5300. The manual covers in detail how to safely and effectively use your new processor. The procedures outlined in this manual should be followed to ensure safe operation and longevity of your machine. The parts manual covers all parts you may need to order in case of accident or breakdown. Please read completely through this manual before beginning operation of your new machine.

Safety Precautions

The following safety precautions MUST be followed to ensure safe operation of the Bale King bale processor.

- **ALWAYS** turn **OFF** the tractor when leaving the operating platform.
- **DO NOT** stand in front of the discharge chute while the machine is running.
- **DO NOT** walk or move under the bale forks when they are in the upward position, unless the cylinder safety lock is in place.
- **DO NOT** enter the machine while in operation.
- **DO NOT** clean machine while in operation.
- **DO NOT** stick any device into the machine to clear debris while the machine is in operation.
- **ALWAYS** turn off the machine when cleaning the machine, removing twine, or hooking/unhooking the machine
- **ALWAYS** use safety chain when towing the machine on a highway.
- **DO NOT** operate if any part of the **PTO safety shielding** is missing or is not secured.

Safety Decals

Power Take-off:

The operator must obey all safety labels and must maintain the proper shielding. A high percentage of drive-line injuries occur when safety shielding is missing or not functioning properly.

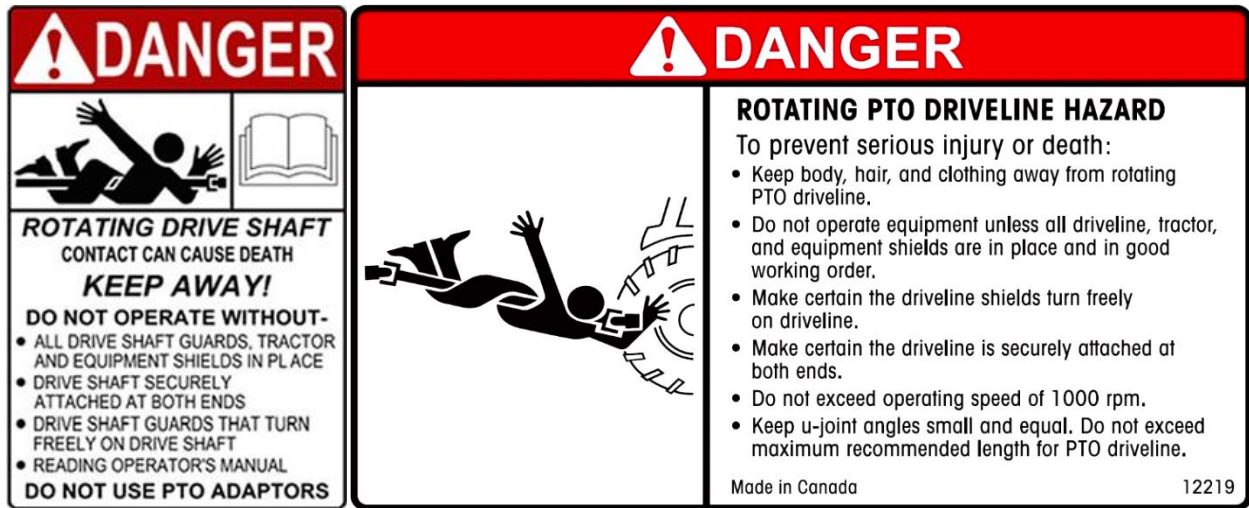

DANGER: *Contact with a rotating drive-line can cause serious injury or death.*

Discharge:



DANGER: *Do not stand on the discharge side of the machine while it is in operation.*

Rear Fork Lift Area:



DANGER: *Stand clear of lift area. Do not stand under the forks if tractor is running or if bale is resting on forks. Automatic hydraulic safety locks are installed.*

Deflector Safety Lock:

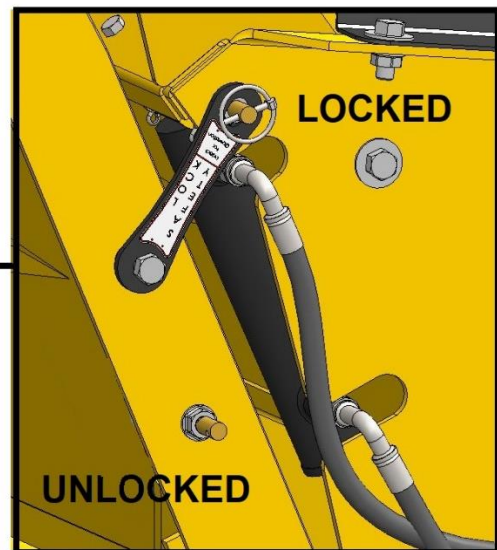

Unlock for operation, Lock for transport and storage

Transportation

The Bale King 5300 can be safely towed on public roads, provided the following precautions are met:

Weights and Dimensions

- The towing vehicle must be suitable for the weight being towed.
- Check with local authorities regarding transport on public roads. Follow all applicable laws and regulations.
- Be aware of your size and weight. Adjust your driving accordingly

	Empty			Loaded		
	5300	5300X ¹	5300TR ²	5300	5300X ¹	5300TR ²
Total Weight	4400 lb	5070 lb	5200 lb	8000 lb	10 500 lb	10 750 lb
Hitch Weight	1250 lb	1320 lb	1540 lb	2000 lb	1600 lb	2200 lb
Length	16'-6"	16'-6"	16'-6"	20'-10"	20'-10"	20'-10"
Width ³	9'-10"	9'-10"	10'-9"	9'-9"	9'-9"	10'-7"
Height	8'-7"	8'-7"	8'-7"	11'-0"	11'-8"	11'-0"

NOTE 1. The 5300X features the optional 3-bale kit

NOTE 2. The 5300TR features the optional Total Ration grain tank

NOTE 3. Width can be reduced to 8'-6" by folding the deflector

Speed

Tow Vehicle Weight	Empty Processor	Loaded Processor
10000 lb and Under	32 km/h (20 mph)	Not recommended
Over 10000 lb	40 km/h (25 mph)	32 km/h (20 mph)

- The processor features implement tires and hubs and is not suitable for high speed travel
- The processor does not have brakes.
- Slow down for rough conditions, turns, and steep declines.
- If towing long distances, ensure the machine is empty (no bales in tub or on fork)
- If hauling one bale only, place it in the tub instead of on the fork.
- If hauling two or more bales, speed should be further reduced. Note that there will be a significant amount of weight behind the processor axle, causing more "tail whip". This also raises the center of weight of the machine.
- Failure to heed these warning may result in loss of control or death.

Safety Chain, Jack, PTO, and Hydraulics

- ALWAYS ensure that the safety chain is properly installed. There should be enough slack to allow for turning, but not so much that the chain drags on the ground.
- Ensure that the jack is installed in its storage position on the front tub wall.
- Ensure that the PTO and hydraulic hoses are properly secured
- PTO and hydraulic lines must be connected to the tractor during transport.
- If towing with a pickup, the outer PTO shaft must be removed, and the inner shaft and hydraulic hoses properly secured. The exposed end of the inner PTO shaft should be covered to protect the splines from dust/rocks, etc.

Wheels and Tires

- Check tire pressure and wheel torque. Wheels must be retorqued after 1 hr if being transported for the first time.

Tire Pressure	24 psi	Wheel Torque	125 ft-lb
----------------------	--------	---------------------	-----------

- If transporting long distances, periodically check the tires and hubs for high temperatures. If heating up, you must slow down.

Lights and Marking

- Tow vehicle must have a 7-pin round trailer plug
- Plug in lights and check for proper function and visibility (flashing amber lights, red tail lights and brake lights).
- If towing with a pickup, an adapter will be required to plug into the trailer plug. When braking, both amber lights should activate. Tail lights should always be on.
- Ensure that the supplied SMV (Slow Moving Vehicle) sign is clearly visible from the rear
- Ensure that the reflective markers are cleaned, and visible from all sides

Safety Locks

- Lift the forks all the way up. If carrying a bale, only lift enough for appropriate ground clearance.
- If applicable, the 3-bale clamp should be closed.
- If possible, the deflector should be in the folded position.
- Ensure that the deflector safety lock is installed



FEATURES & OPERATION

Power Take-off

The Bale King bale processor has a PTO shaft which is splined on both ends. The implement end uses a 1-3/4"-20 spline with wedge lock bolts. Install onto the gearbox and tighten the wedge bolts. The bolts should be torqued to **160 ft-lb** and re-torqued after 8 hrs of use.

The tractor end comes standard with a 1-3/8"-21 spline quick detach constant velocity joint. An optional 1-3/4"-20 spline yoke is available through your Bale King dealer.

The Bale King processor is designed to use a minimum of **100 HP**. The drive shaft is shear-bolt protected. The machine must be operated at **1000 PTO RPM**.

NOTE: *Spread yokes and twisted drive shafts are signs of OVERLOAD, not a manufacturer's defect and therefore not covered by warranty.*

- **DO NOT** operate the machine using a spline adaptor. Use of adaptors will **void warranty** due to damage caused to the tractor PTO, PTO driveshaft, or implement.
- **DO NOT** operate at 540 rpm, or use any kind of adaptor to connect to a 540 rpm spline.
- **ALWAYS** ensure that the PTO shaft is attached securely to the tractor. When the processor is not hooked to the tractor, store the shaft on the PTO holder.
- **DO NOT** transport the processor without securing the PTO shaft. See next page for securing instruction.
- **ALWAYS** ensure that the drawbar is adjusted to **16"** from the end of the tractor PTO shaft to the center of the hole in the drawbar.

Operation

To engage the rotor for processing a bale, be sure the PTO shaft is properly connected to the tractor. Engage the PTO at idle. After the PTO is fully engaged, increase PTO speed until it reaches 1000 RPM.

The processor must not run at any speed less than 1000 PTO RPM as it may result in the flails springing back against the rotor after they come in contact with the bale. This "***backslap***" may cause flails to fatigue and excessive vibration which may cause the bearings to fail. Bales may be dumped into the tub while the rotor is stopped or while it is running.

Shear Bolt

All new Bale King processors are equipped with a **shear bolt** clutch located at the implement end of the PTO shaft. The correct size shear bolt is **3/8 x 2" Fine Thread Grade 5 with Stover Lock Nut**. Any other size or grade will **damage** the shear assembly. Spare shear bolts are shipped with each new machine and are stored along the front top lip of the tub.

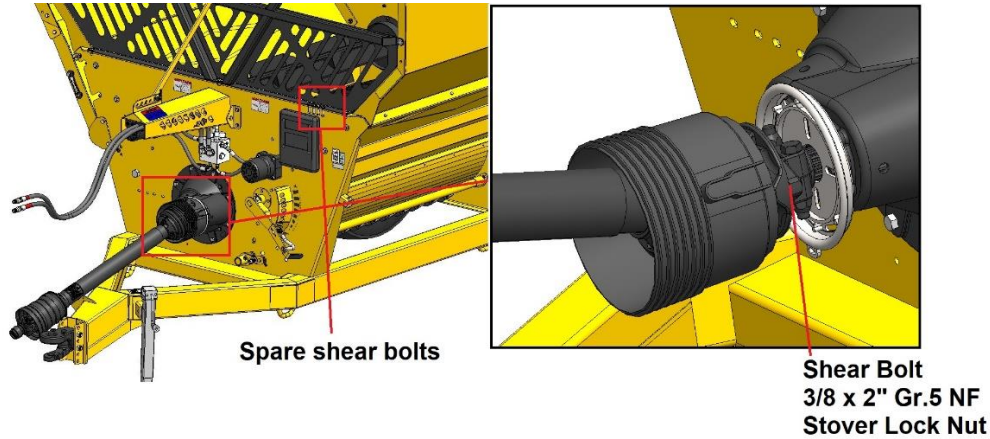

If your shear bolt is shearing excessively you may be over-loading the machine. If this occurs raise the grate assembly to make the machine less aggressive, or roll the bale more slowly. **Always ensure that your machine is running at 1000 PTO RPM.**

NOTE: Please consult your local dealer to help pinpoint any problems.

PTO Holder

A PTO shaft holder is standard with your new Bale King, for safe storage of the PTO shaft when the processor is not in use.

When unhooking the PTO shaft from the tractor, retract and then swing the PTO to the right to rest the PTO on the holder.

DO NOT transport the machine with the PTO in the holder. Slide the outer PTO shaft out and secure elsewhere. When transporting, fasten the inner PTO shaft to the machine and cover the open splined end.

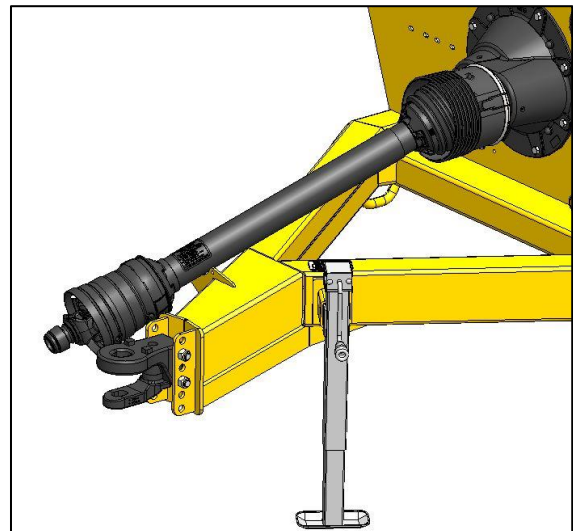

PTO Use and Maintenance

Shut **OFF** the tractor engine and remove the key before doing any maintenance on the machine. Use **ONLY** genuine **Weasler** parts when replacing any worn or damaged PTO components.

Length:

Confirm the minimum and maximum working lengths of the drive-line. The telescoping tubes must overlap at least 1/3 of their length when in use. The PTO is designed to be used with a drawbar length of 16" from the end of the PTO shaft. Adjust your tractor accordingly.

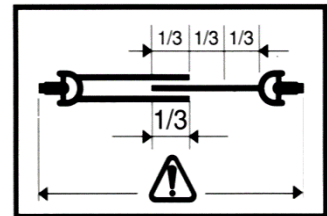

Shielding:

Be sure that the shielding is not damaged and rotates freely on the drive shaft.

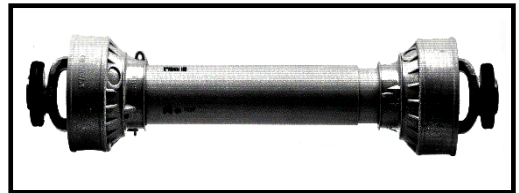

Working Angles:

Constant Velocity joints can operate up to 80 degrees for short periods of time. Do not operate for long periods on sharp angles.

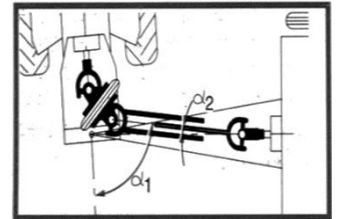

Attachment:

Be sure the drive-line is properly attached and all bolts and screws are tight on the implement input shaft and on the tractor PTO shaft.

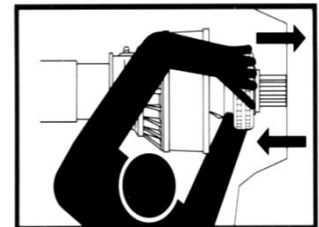

Storage:

When not in use, cover or protect the drive shaft from the weather.

When removed from the machine store both halves together to prevent damage. Check all components for proper function and lubrication before use.

**BEFORE ATTEMPTING ANY REPAIR PROCEDURES,
ALWAYS USE APPROPRIATE EQUIPMENT SUCH AS
SAFETY GLASSES, SAFETY SHOES, AND GLOVES**

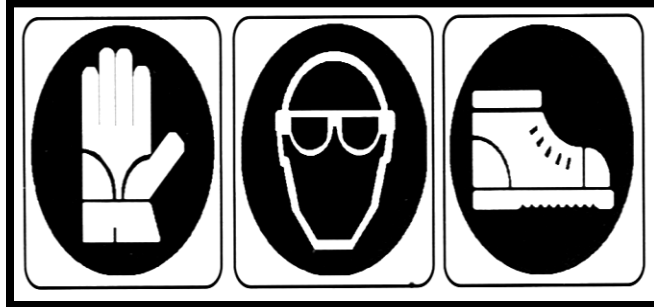

Shield Removal:

- To remove the shield, pop out the red snap, then rotate the guard on the bearing to line up the three tabs with the openings and pull it off away from the knuckle joint.
- Remove the nylon bearing from the shaft by spreading it open.



Shield Assembly:

- Be sure to lubricate the groove in the inner yokes where the shield bearing rides. Reinstall shields in the reverse order that they were removed.

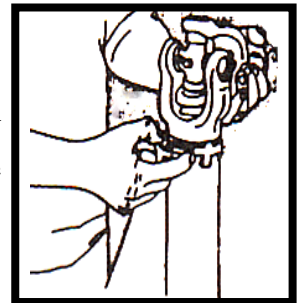

Hydraulics

WARNING: *Pressurized hydraulic fluid can cause serious injury.*

- When working with hydraulic equipment, eye and hand protection should be worn.
- Do not test for leaks with bare hands.
- Relieve any pressure before removing a hose or fitting.
- Never work under components raised by hydraulic equipment unless supported externally.



There are three sets of hydraulic hoses to connect to the tractor. Each hose has a coloured marker to identify its function. They should be connected at best convenience for the tractor's controls. Note that the hoses are paired by colour and the following tables show the operation when pushing oil into the hose with the longer marker.

26483		5300 – 3 Remote	
	Long Blue		Lift rear fork
	Long Yellow		Lift deflector
	Long Red		Agitators rotate clockwise

An optional diverter kit is available to allow the Bale King 5300 to run using only two sets of hoses. The function is then determined by a control box, mounted in the cab of the tractor.

25091		5300 – 2 Remote	
	Control Box	<i>“FORK”</i>	<i>“DEFLECTOR”</i>
	Long Blue	Lift rear fork	Lift deflector
	Long Red		Agitators rotate clockwise



Always set the tractor's hydraulic flow at a lower rate and adjust it upward until the desired speed is reached. Excessive oil flow may damage the flow divider cartridge.

An optional 3-bale kit is available to allow the Bale King 5300 to carry an extra bale on the rear of the machine (see page 23). If this kit is installed, an additional clamp is added to the hydraulic functions. This changes the hydraulic setup as shown in the following table.

34986	5300X – 2 Remote			
	Control Box	<i>“AUXILIARY”</i>	<i>“FORK”</i>	<i>“DEFLECTOR”</i>
	Long Blue	Clamp bale	Lift rear fork	Lift deflector
	Long Red	Agitators rotate clockwise		
22044	5300X – 3 Remote			
	Control Box	<i>“FORK”</i>		<i>“DEFLECTOR”</i>
	Long Blue	Lift rear fork		Lift deflector
	Long Red	Agitators rotate clockwise		
	Long Green	Clamp bale		
22043	5300X – 4 Remote			
	Long Blue	Lift rear fork		
	Long Red	Agitators rotate clockwise		
	Long Yellow	Lift deflector		
	Long Green	Clamp bale		

An optional grain tank kit is available to allow the Bale King 5300 to carry 40 bushels of grain on the side of the machine (see page 22). If this kit is installed, additional motors are added to the hydraulic functions. This changes the hydraulic setup as shown below:

22045	5300TR – 2 Remote			
	Control Box	<i>“AUXILIARY”</i>	<i>“FORK”</i>	<i>“DEFLECTOR”</i>
	Long Blue	Discharge grain	Lift rear fork	Lift deflector
	Long Red	Agitators rotate clockwise		
22044	5300TR – 3 Remote			
	Control Box	<i>“FORK”</i>		<i>“DEFLECTOR”</i>
	Long Blue	Lift rear fork		Lift deflector
	Long Red	Agitators rotate clockwise		
	Long Green	Discharge grain		
22043	5300TR – 4 Remote			
	Long Blue	Lift rear fork		
	Long Red	Agitators rotate clockwise		
	Long Yellow	Lift deflector		
	Long Green	Discharge grain		

If both kits are installed on the machine, the hydraulic setup is as shown below:

		5300XTR – 2 Remote			
32006	Control Box *	<i>“GRAIN TANK”</i>	<i>“AUXILIARY”</i>	<i>“FORK”</i>	<i>“DEFLECTOR”</i>
	Long Blue	Discharge grain	Clamp bale	Lift rear fork	Lift deflector
	Long Red	Agitators rotate clockwise			
		5300XTR – 3 Remote			
32005	Control Box	<i>“AUXILIARY”</i>	<i>“FORK”</i>	<i>“DEFLECTOR”</i>	
	Long Blue	Clamp bale	Lift rear fork	Lift deflector	
	Long Red	Agitators rotate clockwise			
	Long Green	Discharge grain			
		5300XTR – 4 Remote			
32007	Control Box	<i>“FORK”</i>	<i>“DEFLECTOR”</i>		
	Long Blue	Lift rear fork	Lift deflector		
	Long Red	Agitators rotate clockwise			
	Long Yellow	Clamp bale			
	Long Green	Discharge grain			



* 2 Option – 2 Remote Control Box with additional push button switch

Hose Holder

The hydraulic hoses may need to be adjusted to avoid damage from rubbing on the PTO shaft. This can be done by lifting or lowering the hose holder. Loosen the pin handle, then lift the end of the hose holder to drop the pin into the slot. Then adjust the height as desired and catch the pin into the desired notch. Finally, retighten the pin handle to prevent it from switching positions if the machine bounces.

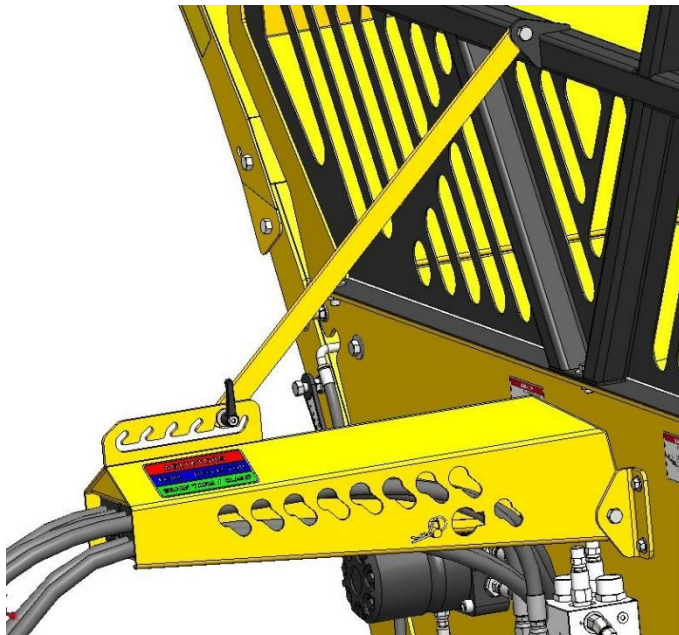

Loosen handle
Lift end of holder
Slide pin in slot
Choose setting
Tighten handle

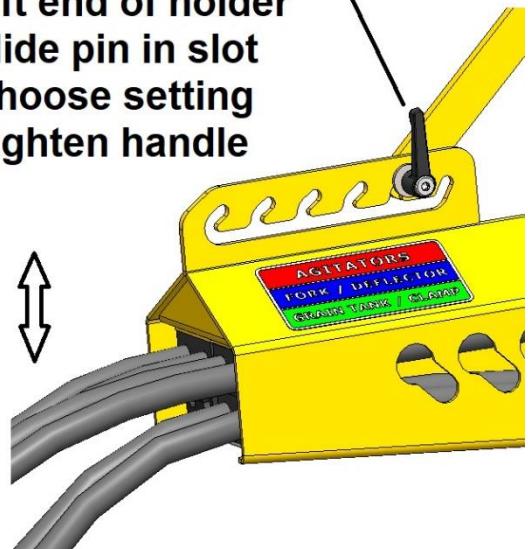

Implement Tongue

The adjustable hitch on the Bale King features a cast single tongue with optional clevis insert (BMI #29786). This allows for use with tractors equipped with a hammer strap or with a single drawbar. It also allows the machine to move independently over rough terrain without bending the draw pin.

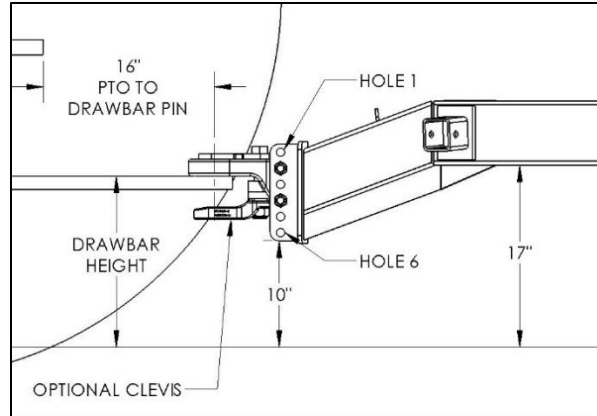

- Make sure that the drawbar is set to **16 inches** behind the PTO shaft for proper PTO length.
- Adjust the hitch height to match the tractor drawbar height as close as possible per the chart

Drawbar Height	Holes
17.5"	1 & 3
16"	2 & 4
14.5"	3 & 5
13"	4 & 6

- This will make the frame run level and keep the PTO as straight as possible.
- **DO NOT** install the clevis insert if using a tractor with a hammer strap as this will bend the hitch pin.
- **ALWAYS** connect the safety chain during road transport

Rear Forks

The rear fork bale tines can be adjusted side to side by removing the pin connecting the tine to the machine and replacing the tine in the other available gap. The widest position is recommended for all situations, except for the smallest bales. Always use tines in the same position on either side to keep the load on the forks and cylinders balanced.

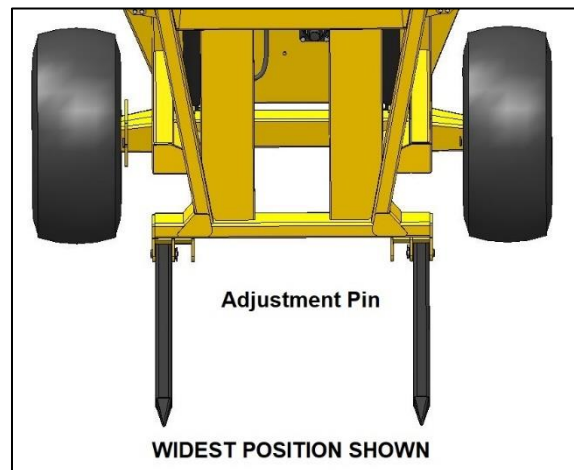

For transport, and safety when working under the forks, the Bale King 5300 is equipped with hydraulic safety valves that do not allow the forks to come down without hydraulic pressure. Lowering the forks using the tractor controls overrides this valve and allows the forks to lower. Never stand under the forks. When greasing or servicing around the rear end, the forks should be down. Never attempt to loosen or replace hydraulic hoses while the forks are up.

Loading Bales



When loading bales into your Bale King bale processor, the following procedure should be followed:

- Position the tractor and the Bale King so as to be lined up to back straight into the row of bales.
- When close to the bale, lower the forks completely (you will feel a light vibration as the forks bottom out against the frame.)
- Back completely under the first bale.
- Allow the tractor to move forward while lifting the bale, because the bale fork moves away from the machine while loading.
- If you are loading from the same row you can dump the bale into the machine and back straight into the second bale. If you are going to a different stack for the second bale only raise the first bale enough to clear the ground. Move to the next row and align the machine to the bale before dumping the bale into the tub. This gives you good visibility to line up to the second bale.
- Once you have the first bale in the tub and the second bale on the forks, raise the bale fork about 1/4 of the way up. You can now transport to your feeding or bedding area to begin processing.

Note: *Carry the bale as low as possible to lessen the stress on the cylinder shafts. Carrying the bale too high may bend hydraulic cylinder shafts.*

- When the first bale has been processed, it is common practice to leave the rotor running at full speed when loading the second bale into the bale chamber from the rear forks. However, the agitators should be stopped during loading.

For information on the optional 3-bale kit, see page 23.

Hoop Grate Adjustment

There are eight adjustment settings for the hoop grate on the bale processor. These settings determine the rate of feed of the bale you are processing and the how fine the cut will be. To adjust, pull the spring handle outward, then swing the handle “UP” for a more aggressive cut, or “DOWN” for less aggression. Then release the spring handle to engage the pin in the desired hole

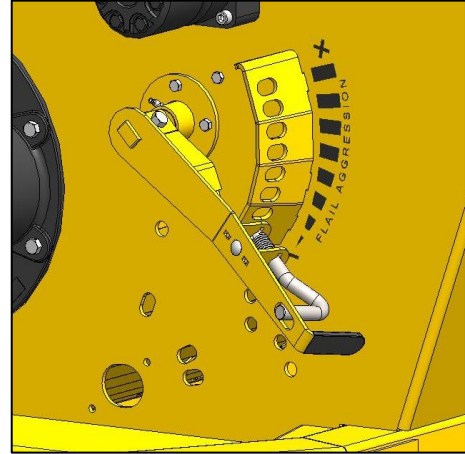

When there is a bale in the tub, the bale’s weight will be placed on the hoop grates, making adjustment more difficult. Adjust the machine when it is empty when possible.

- **Position #1 (Bottom):** Highest grate setting for finest cut and slowest rate of feed. Used for tough processing feeds such as silage bales, or other wet materials.
- **Position #2 - #5:** Normal operating range. Machine gets more aggressive as grate is lowered (handle moves “up”).
- **Position #6-8 (Top):** Lowest grate positions, most aggressive, fastest rate of feed.

The Bale King should be adjusted according to bale conditions to achieve a rate of feed of approximately **1.5 to 2 minutes**. Light brittle material such as wheat straw may allow faster processing while tough stringy material such as slough hay, green feed, or flax will require slower processing. Hoop grate adjustment should be checked periodically.

NOTE: Processing a bale too rapidly may cause unnecessary machine deterioration.

NOTE: Upper grate position should be approximately 1/8” flail protrusion. Lower grate position should allow 2-1/2” flail protrusion. Contact your Bale King dealer if this can’t be achieved.

Deflector

The Bale King 5300 is equipped with a hydraulic side deflector to change the discharge distance and distribution. It also comes with a flipping rubber flap for superior control of the spread pattern.

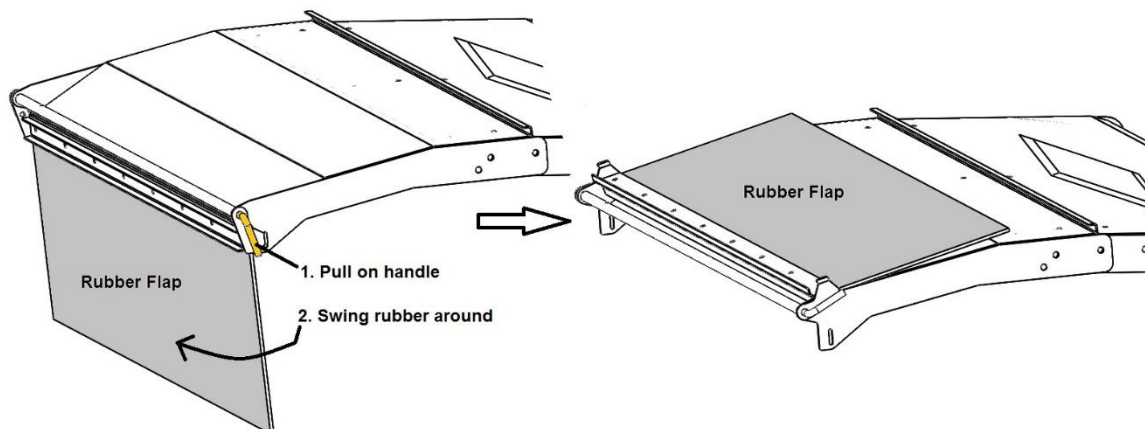

Moving the deflector to the **down** position and flipping the rubber down (above left) will allow the hay to be laid in a windrow, or bunk feeder. Swinging the deflector **up** will allow you to spread straw out over a large area. If you also flip the rubber up (above right), you will be able to "fine tune" the discharge, to control the height and distance.

To flip the rubber, simply pull on the handle and swing into position. Then push the handle so that the tabs catch in the notches and lock into place.

The Bale King 5300 deflector will bunk feed to a distance of 35" from the tire when in the lowest position. When the deflector is not folded, the transport width of the machine is 9'-10".

For transport and storage, the deflector lock should be put in place by swinging the lock as shown and fastening with a lynch pin.

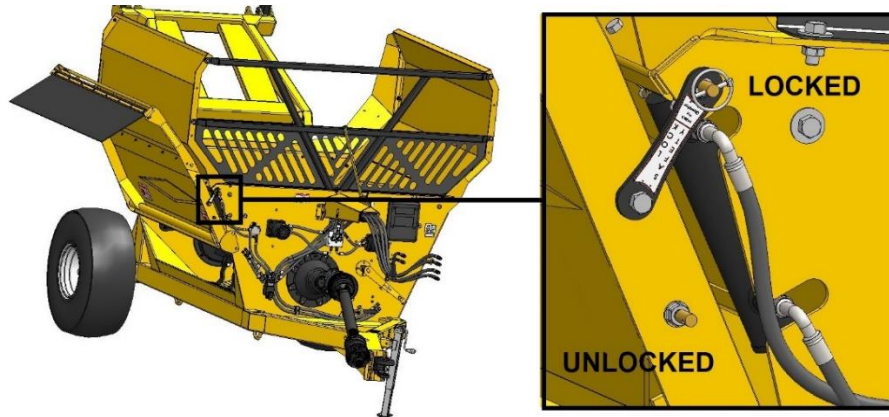

The Bale King 5300 deflector also has the ability to fold for more compact long-term storage or long-distance transport.

- Move the deflector to its lowest position
- Remove the 7 top carriage bolts from the deflector.
- Loosen all the 4 bolts on the front and back of the deflector.
- Raise the deflector to its highest position with the hydraulics. Remove the bolts closest to the machine center (both front and back) and swing the outer deflector down.

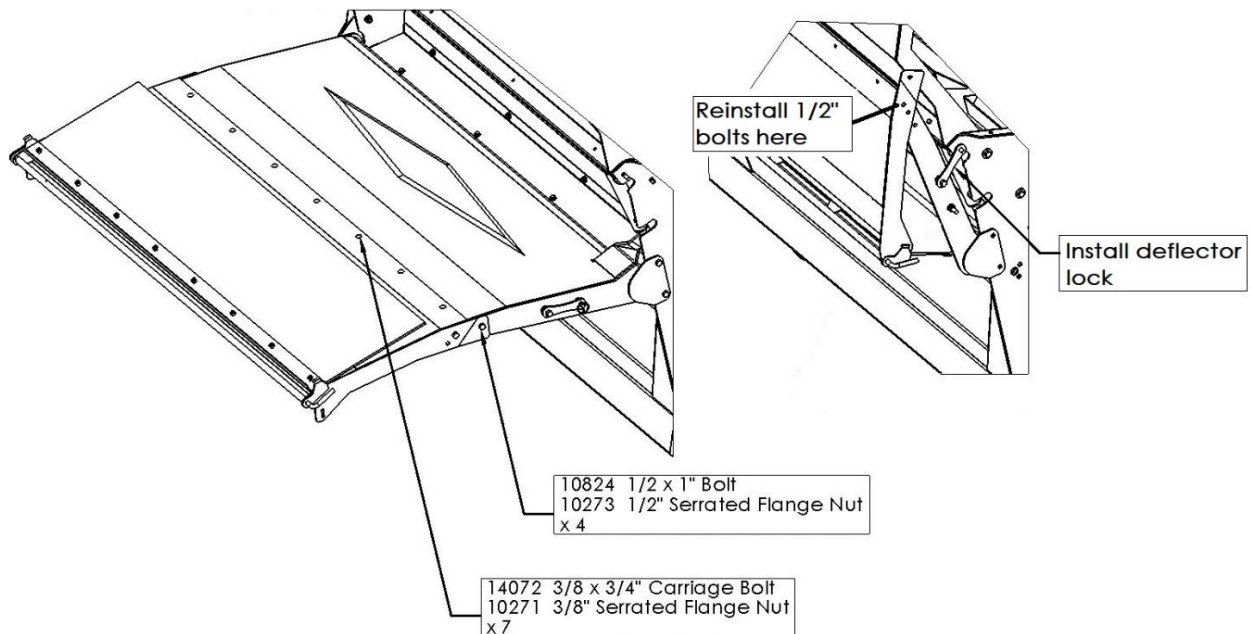

BE CAREFUL WHEN LIFTING THE DEFLECTOR WITH THE OUTER PANEL ABLE TO PIVOT TO AVOID CONTACTING THE TIRES.

Agitators

The Bale King is equipped with a flow divider/combiner and two hydraulic motors for turning the bale.

Once the main rotor is turning at full speed the bale can be turned in either direction to begin processing. The faster the bale is turned in either direction, the faster it will be processed. It may be necessary to change direction of the bale when loose debris builds on either side of the bale chamber. This will remove the loose debris preventing spillage from the machine. This is especially true when processing soft core bales. By reversing direction regularly, soft core bales will process more evenly.

If the tractor has a flow control, adjust the oil flow so that the agitators run at a low rate. Adjust the flow as needed to find the best speed to process a bale (approximately 30 rpm or 12 gpm flow). Turning bales too fast can result in rotor overloading resulting in flail “backslap” which in turn causes flail and bushing damage. High agitator speed may also cause damage to the hydraulic motors and excessive twine and material build-up on the agitators.

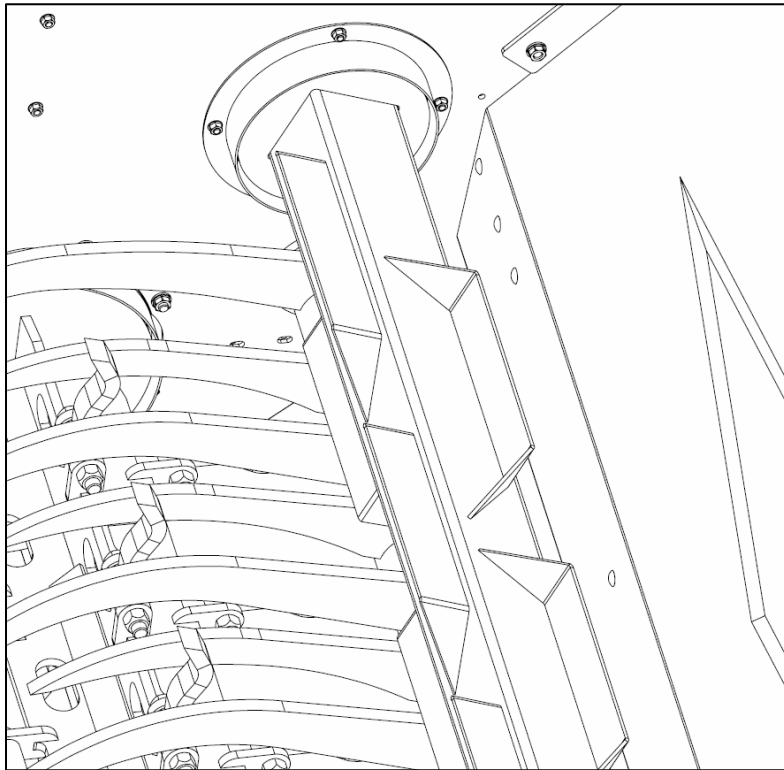

Optional Diverter Kit

The Bale King 5300 processor has an optional diverter kit which allows it to operate using only 2 hydraulic remotes. The fork and deflector functions are then controlled by a cab-mounted switch box. This box must be wired up to the tractor's electrical system. You may use the provided plug to plug into the accessory outlet. If this is not available, the plug can be disassembled, and wired as necessary.

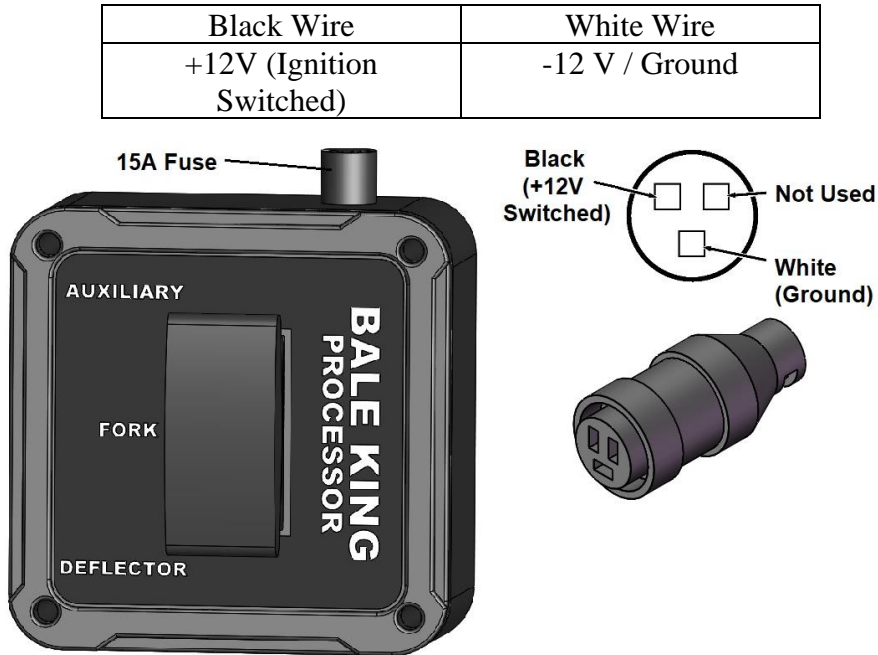

	5300	5300X	5300TR	5300XTR
Diverter Kit (4 Remote)	-	22043	22043	* 32007 *
Diverter Kit (3 Remote)	26483	*22044 *	* 22044 *	* 32005 *
Diverter Kit (2 Remote)	* 25091 *	* 34986 *	* 22045 *	* 32006 *

*** These kits require a control box.**

If changing from one package to another, contact Bridgeview to obtain an adaptor kit

A 4-pin plug is used to power the diverter valve on the processor. If no power is supplied, the hydraulics will still control the rear forks, but the deflector will not be functional. If the switch in the tractor is activated, the deflector can be controlled. On 5300 machines with an optional “TR” Grain Tank or “X” Three Bale Kit, this box can also control grain flow or the 3 Bale Clamp (as “Auxiliary”).

The diverter kit also features a pilot operated check valve to ensure that the deflector will not fall down due to leaking across the valve.

Optional Fine Chop Kit

The Bale King 5300 processor has an optional fine chop knife kit (**BMI # 32117**) available to go into the lower tub area. This option is available if you require a finer cut on the material which you are processing such as slough hay and silage bales.

It is recommended that the knives be lowered when bedding straw as it will affect your spread pattern. Adjust the machine as needed.

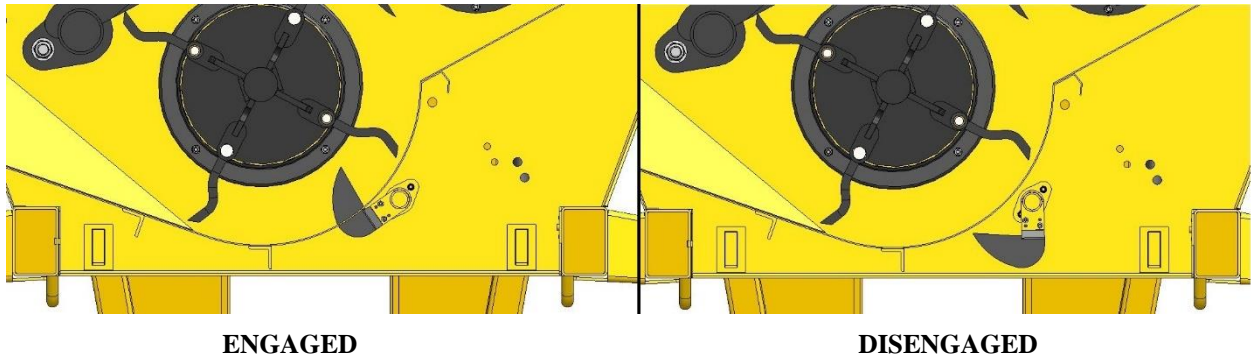

There are two settings for the fine chop, depending on how fine you wish to cut the material. These settings achieved by pulling on the handle (towards the back of the machine), then selecting the desired hole.

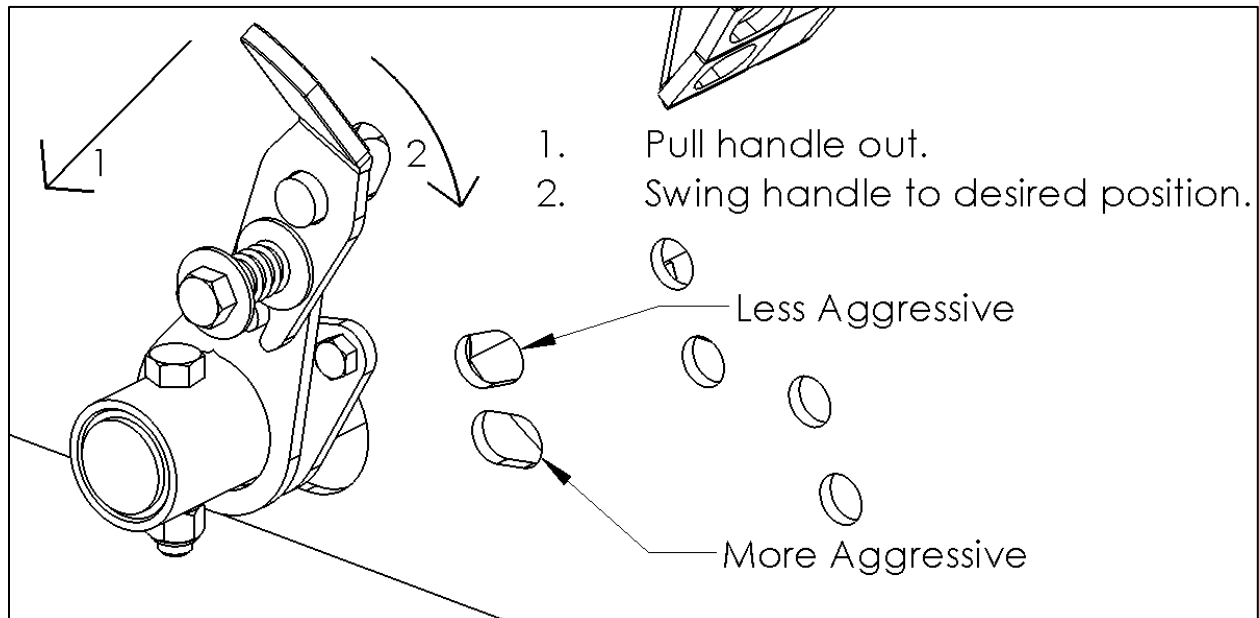

Optional Total Ration Grain Tank (5300TR)



The Bale King 5300 has an available 40-bushel grain tank, which allows grain to be discharged on top of a windrow of processed hay, or independently out the right side of the machine. This bolt-on kit changes the processor to a 5300TR (Total Ration).

The tank is located on the left side of the machine and features a large opening, 5 ft off the ground for easy filling. A flow control valve allows you to adjust the speed of the augers so that you can meter the grain flow for different situations. It is recommended to determine your desired rate based on driving speed and the flow rate of the tractor. Setting the valve to "0" will give no grain, while setting it to "10" will be full speed.

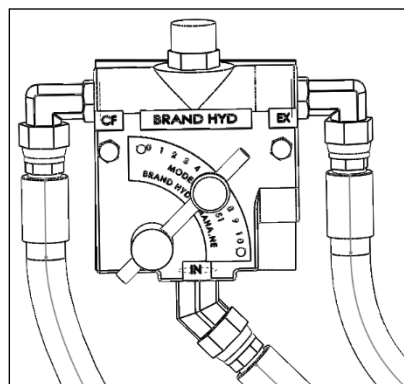

Cleanout doors are located at the bottom end of both the cross-auger, and the grain tank. It is recommended that both be cleaned out at the end of every season.

Contact Bridgeview for inquiries about adding this kit to an existing machine.

Optional 3 Bale Kit (5300X)



The Bale King 5300 has an available attachment kit which increases the carrying capacity of the processor by 50%, while maintaining the easy maneuverability of the two-bale processor. The attachment kit stores the second loaded bale behind the first and above the third in a set of powerful hydraulic clamps.

The 3 Bale Kit changes the loading process of the bale processor slightly. The loading of the second bale involves lifting the bale so the fork and bale are parallel to the ground, or just above this point. The clamp will be closed around the bale at this point and the fork can be lowered back to the ground. The third bale can then be backed under and lifted until it is lightly supporting the second bale. After the first bale processing is complete, the clamp can be opened (while the third bale is supporting the second), and the fork can be lifted until the third bale pushes the second into the tub.

Contact Bridgeview for inquiries about adding this kit to an existing machine.

An optional back-up camera (pg. 27) is available to aid in the loading process by giving the operator direct visibility of the loading forks, even with a bale in the tub. See the next section for more information about loading.

3 Bale Kit Loading Sequence:

1. Position the tractor and the Bale King so as to be lined up to back straight into the row of bales.
2. Ensure the bale clamp is opened fully.
3. When close to the bale, lower the forks completely (you will feel a light vibration as the forks bottom out against the frame).
4. Back completely under the first bale.
5. Lift the first bale, allowing the tractor to roll forward slightly while lifting the bale. This is because the lifting fork moves away from the machine slightly when loading.
6. If you are loading from the same row, you can dump the bale into the machine and back straight into the second bale. If you are going to a different stack for the second bale, only raise the first bale enough to clear the ground. Move to the next row and align the machine to the bale before dumping the bale into the tub. This gives you good visibility to line up to the second bale.
7. Once you have the first bale in the tub and the second bale on the forks, raise the second bale until it presses on the bale in the tub and then lower it until the fork is approximately horizontal or just above. Raising and then lowering the bale puts it in the optimal position for clamping and clearance on the bottom bale.



8. Once the bale is in the appropriate location, close the clamp fully and then lower the lifting fork.



9. Back under the third bale and lift the forks until the third bale is lightly supporting the second bale. You will see when to stop lifting as the clamped bale will tilt forward slightly.



10. When the first bale has been processed and the third bale is still lightly supporting the second, open the clamp to release the second bale. Once the clamp is opened, lift the fork until the third bale pushes the second bale into the tub.



11. Once the second bale is processed, the fork can be fully lifted to load the third bale into the tub.



Lockout Mechanism Adjustment and Setting

The 3 Bale Kit is equipped with a lockout mechanism that prevents damage to the clamps if the fork is lifted before the clamps are released. The lockout mechanism works by allowing the clamps to “break-away” if contacted, or if a bale in the fork pushes too hard on a clamped bale. When this happens, a valve is activated which locks out the forks and prevents them from lifting any higher. To reset, lower the bale slightly to release the valve, then open the clamps.



Clamps lift up in slot, activating the valve. Lowering the forks resets this.

Optional Back-up Camera

The Bale King 5300 processor has an optional back-up camera to provide increased visibility while loading bales. This is especially helpful when combined with a 3-bale kit.



There are two versions of the kit.

Standard Kit	Pro Kit
32619	32628
Camera Rated to -20°C (-4°F)	Camera Rated to -40°C (-40°F)

The kit includes a mounting bracket to install the camera on the rear axle of the processor, as well as cables to run to the tractor. The monitor can be installed in the tractor cab, with a plug between the tractor and processor.

SERVICE AND MAINTENANCE

Greasing Locations

Lubricating the Bale King bale processor should be done on a regular basis.

Every 50 bales			
C	Rotor Gearbox	1	3-5 pumps
Every 150 bales			
A	Bale Fork Pivot	2	3-5 pumps
B	3-Bale Kit Arm Pivot *	2	3-5 pumps
D	Hoop Handle	1	3-5 pumps
E	PTO Cross & Bearings	4	5 pumps
	PTO Guard Bushings	2	5 pumps
	PTO Spline	1	8-10 pumps
Every 500 bales (or Annually)			
E	PTO CV Joint	1	30 pumps
F	Agitator Bearings	2	3-5 pumps (DO NOT OVERGREASE)
G	Rotor Bearing	1	3-5 pumps (DO NOT OVERGREASE)
H	3-Bale Kit Cylinder Eye *	2	3-5 pumps
I	Jack	1	8 - 10 pumps
Annually			
J	Wheel Hubs	2	Pack hubs full

* Optional 3-bale kit only

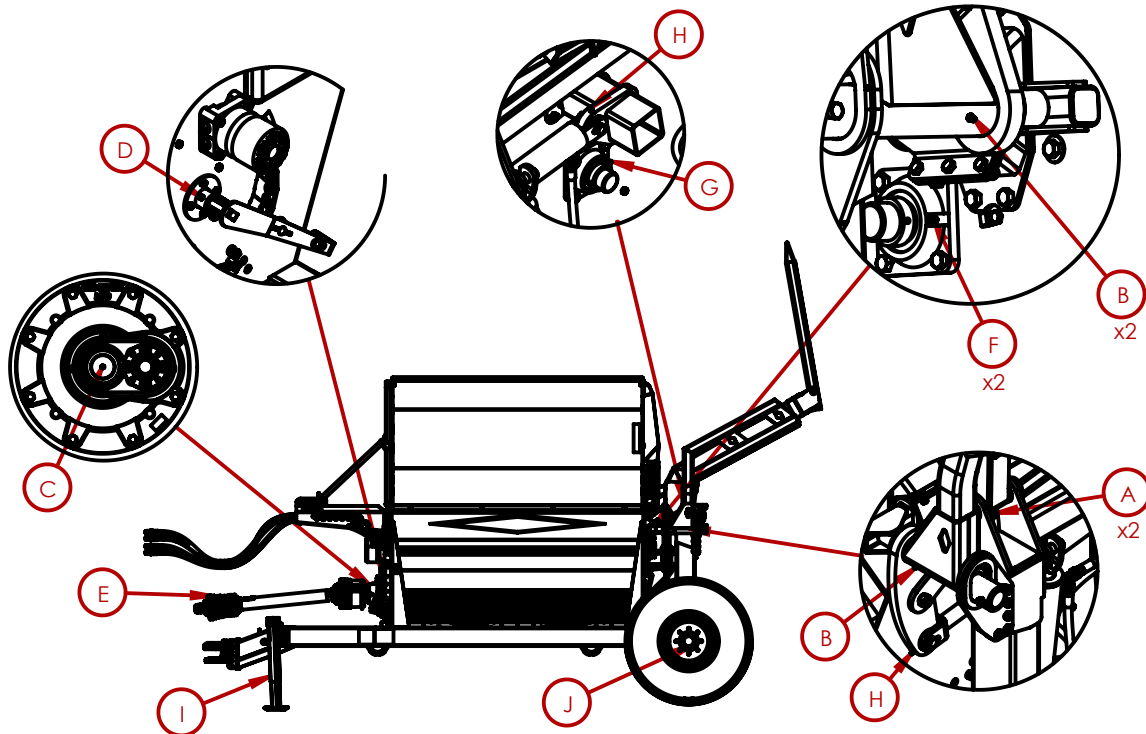

PTO/Driveline

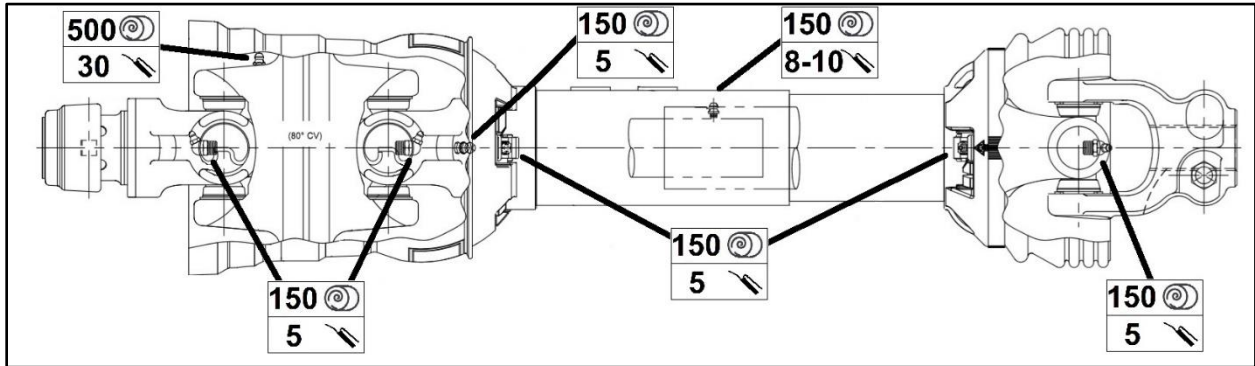

After storage for long periods of time, lubricate and check the function of every driveline component before operating. Failure to grease all the joints will **VOID** warranty.

All zerks can be accessed while the PTO is connected to the tractor **EXCEPT** for the telescoping spline, which can only be accessed when the PTO is fully retracted.

Gearbox

There is one grease zerk on the front of the gear box. Apply 3-5 pumps of good quality grease every 150 bales.

If the gearbox is removed to replace the rotor or perform any other service, add **80 pumps** of grease to the grease zerk upon reinstallation.

The gear box requires GL5 80W90 gear oil. The oil should be filled to the level plug (approximately **500 mL**) and checked on a regular basis. The oil should also be changed at the following intervals:

- 500 bales after first use
- 1000 bales after first use
- Every 5000 bales afterwards, or annually (whichever comes first)

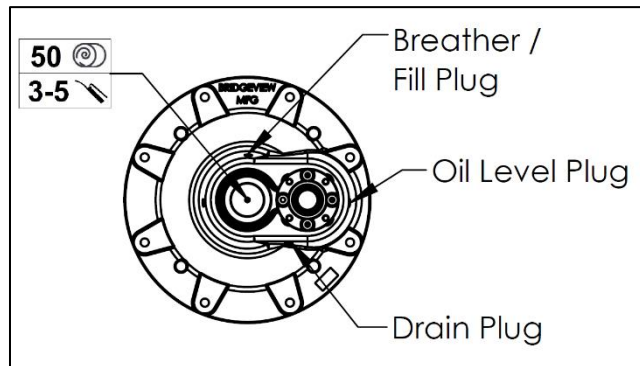

Cylinder Maintenance

The hydraulic cylinders are easily removed for repair or maintenance simply by:

- Lowering the fork (or deflector) to the down position and unhooking the hydraulic lines. Be sure there is no pressure on the lines and mark the line locations so there is no confusion when reinstalling the cylinders. Check hydraulic schematics.
- Removing the cotter pin closest to the frame of the machine and sliding the cylinder pins out
- To reinstall, reverse the removal procedure

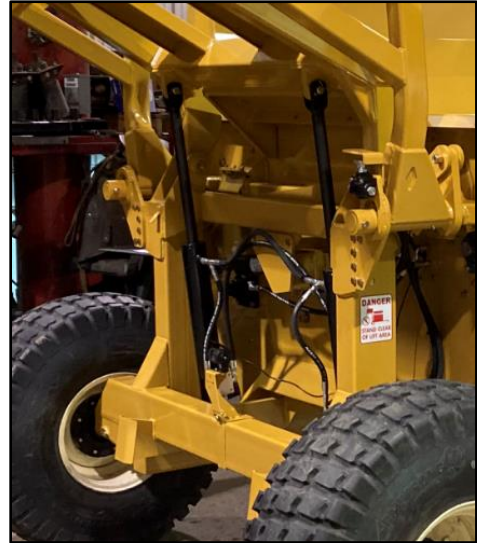

NOTE: *Always cover exposed cylinder shafts with grease to avoid rusting of shafts if the unit is not used for extended periods of time. Rusted cylinder shafts are NOT covered by warranty*

NOTE: *Check all hoses and fittings periodically for leaks. Tighten or replace any dripping components or any worn out hoses.*

Tires

Wheel bearings should be inspected annually for adjustment and lubricated annually. Inspect more often for extensive traveling.

- To tighten the wheel bearings, lift up each wheel (one at a time) until the wheel spins freely.
- Remove dust cap and the cotter pin which retains the castle nut.
- Tighten the nut until the wheel will rotate approximately two turns when given a firm spin.
- Align castle nut to closest hole and insert the cotter pin.
- Pack hub full of grease and reinstall the dust cap.

Proper tire inflation will help to alleviate puncture problems when towing and operating on rough terrain.

Check for proper tire inflation	24 psi
Replace any damaged or worn tires	16Lx16.1 8-ply
Check and tighten wheel bolts on a regular basis	125 ft.lb

Note: Warranty does not cover damaged rims and hubs due to loose wheel bolts or flat tires.

Tire warranty is covered by the tire manufacturer.



Note: When inflating tires, use a clip-on chuck and extension hose long enough to allow you to stand to one side and NOT in front of or over the tire assembly.

Twine Removal

It is natural that twine from the bales will wrap around the rotor as they are being processed. It is recommended to remove the twine from the rotor every 10-15 bales to avoid having so much that it begins to hinder the flail movement. The more often this is done, the easier it is to remove, since the twine has not had a chance to wrap more tightly. The patented “X” shape makes twine removal much easier.

WARNING: Before attempting the removal of twine from the rotor, be sure that the machine is stopped and the tractor is shut **OFF**. Place the tractor in park. Twines can be removed with the use of the optional knife, or any other knife.

An electric device is also available from suppliers to melt the twine & allow it to be pulled off. Once melted, the twine should be removed immediately to prevent damage to the rotor. It is **NOT PERMITTED** to leave the twine burning on the rotor as this has several adverse effects:

- It may take the temper out of the steel, rendering it weaker.
- Loose straw and hay remaining in the machine may ignite causing a fire in the processor.
- Excessive buildup of melted plastic.
- Dry out bushings causing them to wear prematurely.

NOTE: *Bridgeview Manufacturing Inc. VOIDS warranty for any damage caused by twine burning in the processor.*



Twine guards are installed on the machine to keep bale twine out of important areas such as bearings.

- The wheel hubs have a twine guard to keep anything from getting tangled in the wheel bearing. Check for and remove any twine which may have wrapped around the spindle.
- The main rotor and the agitators are equipped with removable twine guards. The guards are mounted to inside of the front and rear walls of the machine. The twine guards are bolted and need to be removed if you need to remove or tighten the bolts on the bearings or the hydraulic motors.
- Remove any twine which may have wrapped around the agitators.

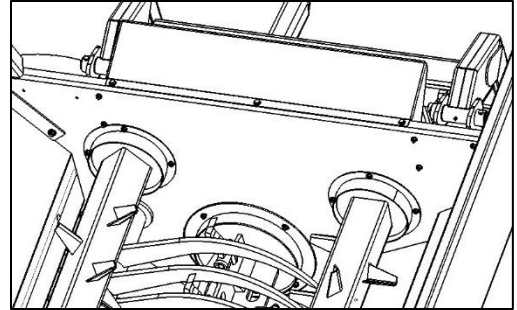
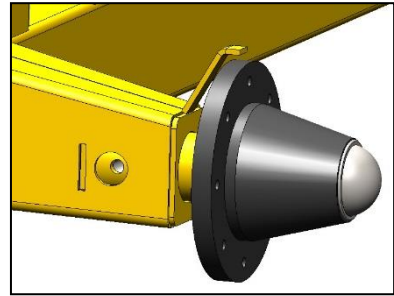

Gearbox and Flail Replacement Procedure

Flail replacement is accomplished by removing the 3/4" x 4-3/4" bolt holding the flail to the rotor. The flail is then lifted away from the rotor. The bushing can now be removed by using slight pressure to push it out of the flail. Inspect the bolt, bushing, and the flail for wear. If wear is excessive, replace with new parts.

Bridgeview Manufacturing Inc. recommends when changing flails to change in **PAIRS** (opposite each other). Processing bales with broken flails causes the rotor to be out of balance and excessive vibration may cause machine deterioration.

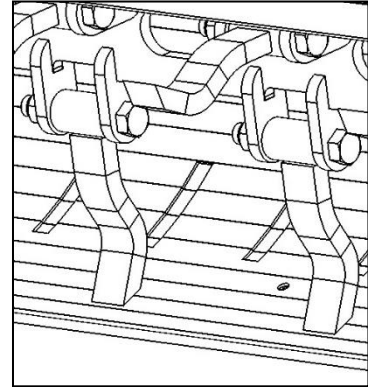

If a new rotor is required, care must be taken when reinstalling:

- Clean the spline and shaft ends of the rotor of any debris
- Clean the inside of the gearbox. Check the splines for damage.
- Slide rear twine guard over the rotor
- Install new rotor bearing (if necessary). Torque to **200 ft-lb**
- Slide the rotor through the rear bearing. Do not tighten collar yet
- Install the gearbox over the rotor spline and bolt to the tub
- Check flail clearance of **1/2 to 5/8"** to tub panel
- Center the rotor in the tub so that the flails are centered between the hoops and slots
- Tighten bearing lock collar **counter-clockwise**. Apply *loc-tite* to the set screw and torque to **100 in-lb**.
- Check gearbox oil to the side plug level (~500 mL). Replace if necessary.
- Add **80 pumps** of grease to the front gearbox grease zerk.
- Install rear twine guard using 3/8" bolts.

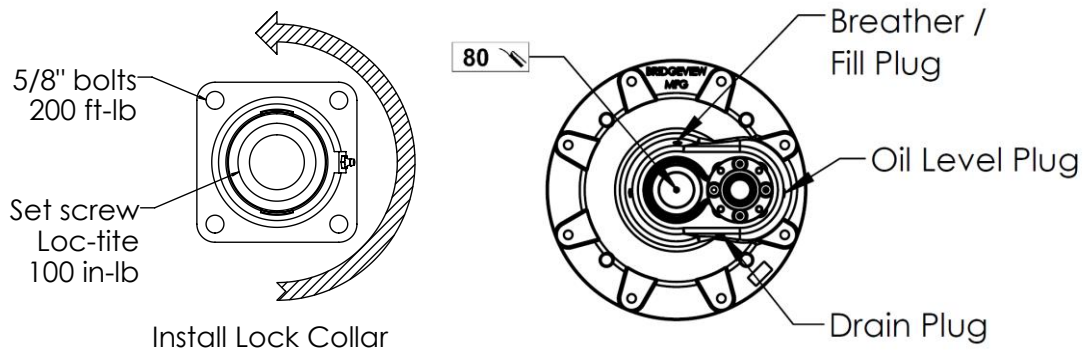

Trouble-shooting Guide

Problem	Possible Cause	Remedy
Excessive main shear bolt breakage	Engaging PTO at high engine speed or too quickly	<ul style="list-style-type: none"> • Idle tractor to engage PTO then bring up to full operating speed • Feather PTO lever into position
	Excessive twine wrapped on rotor causing flail movement to be restricted	<ul style="list-style-type: none"> • Cut twine off rotor
	Broken flails causing rotor to be out of balance	<ul style="list-style-type: none"> • Replace broken flails (in pairs opposite each other)
	Overloading rotor	<ul style="list-style-type: none"> • Set hoops to less aggressive position • Slow rotation of bale • Change direction of bale rotation
	Excessive horsepower	<ul style="list-style-type: none"> • Use smaller tractor
	Incorrect shear bolt used	<ul style="list-style-type: none"> • Use correct shear bolt
	Operating machine at less than 1000 PTO RPM	<ul style="list-style-type: none"> • Operate machine at rated 1000 PTO RPM
Excessive vibration while processing bales	Excessive twine wrapped on rotor causing flail movement to be restricted	<ul style="list-style-type: none"> • Cut twine off rotor
	Broken flails causing rotor to be out of balance	<ul style="list-style-type: none"> • Replace broken flails (in pairs opposite each other)
	Overloading rotor	<ul style="list-style-type: none"> • Set hoops to less aggressive position • Slow rotation of bale • Change direction of bale rotation
	Operating machine at less than 1000 PTO RPM	<ul style="list-style-type: none"> • Operate machine at rated 1000 PTO RPM
	Rotor bearing failure	<ul style="list-style-type: none"> • Replace failed parts
Agitators stopping	Excessive loose material in tub causing agitator to jam	<ul style="list-style-type: none"> • Reverse direction of bale rotation • Turn bale more slowly
	Tractor relief pressure set too low	<ul style="list-style-type: none"> • Set tractor relief pressure to at least 2500 PSI
A single agitator stopping	Mechanical flow divider valve not functioning correctly	<ul style="list-style-type: none"> • Contact your dealer for repairs
	Coupler between motor and agitator broken	<ul style="list-style-type: none"> • Replace failed parts
No grain Flow	Flow control valve set too low	<ul style="list-style-type: none"> • Increase flow rate in tractor or on flow control valve
Flow Control Valve going over relief	Flow control valve relief pressure set too low	<ul style="list-style-type: none"> • Use hydraulic pressure gauge to ensure relief pressure is set to 2200psi.
	Auger chute at too shallow of an angle for grain to clear fast enough	<ul style="list-style-type: none"> • Run auger slower • Run chute at steeper angle
3 Bale Kit not clamping at full pressure	Second bale is being lifted too high before clamping	<ul style="list-style-type: none"> • Lower fork height to horizontal before clamping bale
	Lockout mechanism is set too early	<ul style="list-style-type: none"> • Adjust lockout mechanism to stop clamp at higher fork position

With 3 Bale Kit, fork is not lifting to full stroke	3 Bale Kit is slightly closed	<ul style="list-style-type: none"> • Lower fork and open 3 Bale Kit fully before lifting
--	-------------------------------	---

Features and Specifications

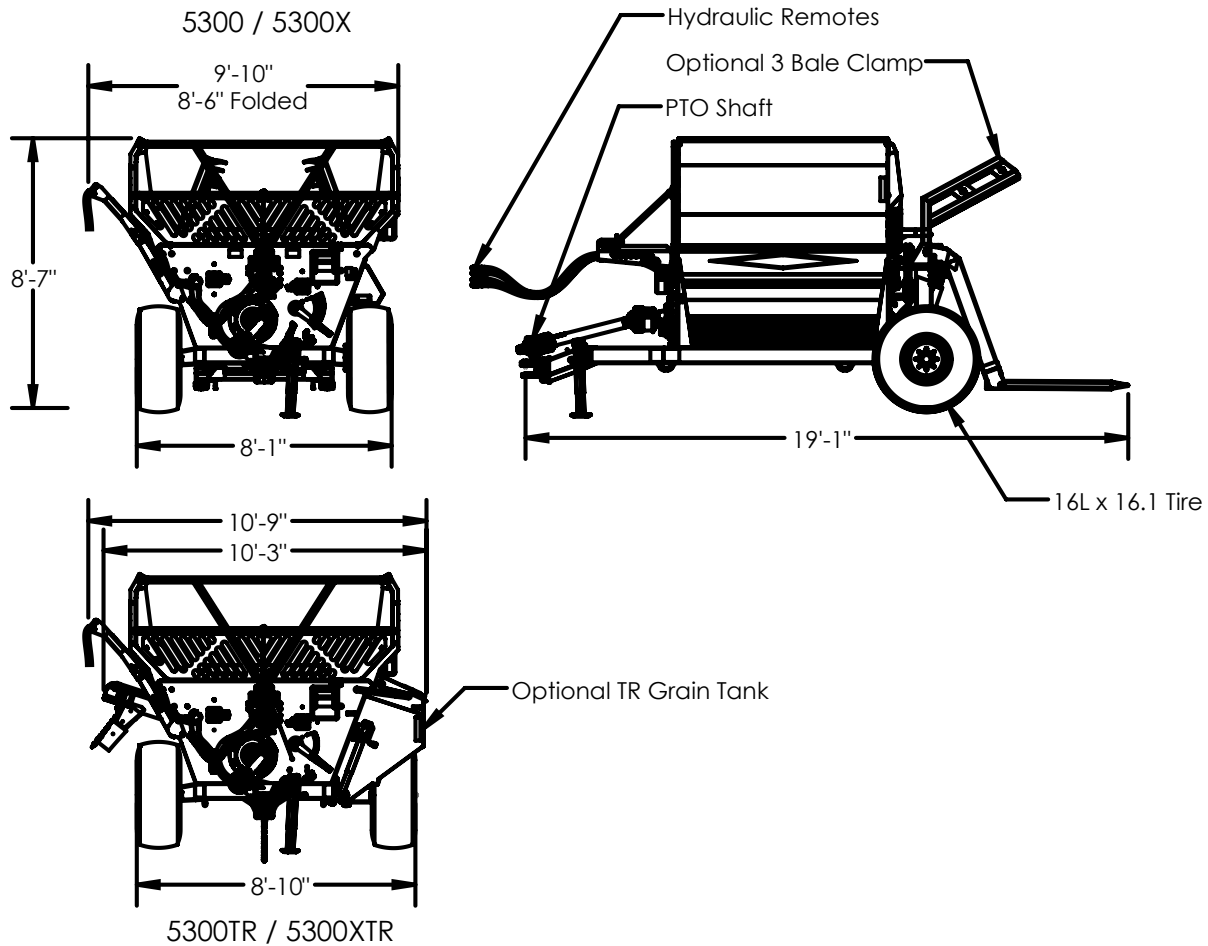

Dimensions:

	5300	5300TR	5300X	5300XTR
Overall Weight	4400 lb	5200 lb	5070 lb	5700 lb
Drawbar Weight	1250 lb	1540 lb	1320 lb	1570 lb
Overall Length (Forks Up)	16'-6"	16'-6"	16'-6"	16'-6"
Overall Width (Deflector Down)	11'-4"	12'-3"	11'-4"	12'-3"
Grain Tank Capacity		40 bushels		40 bushels
Rotor Extended Tip Diameter		27 in.		
Discharge Opening		12 x 80 in.		

Wheels:

Tire Size	16L x 16.1 8-ply
Tire Inflation	24 psi
Wheel Nut Torque	125 ft-lb

Driveline:

Minimum Horsepower	100 HP
	*Ensure sufficient horsepower for terrain driven.
PTO Shaft	Weasler: Cat. 6 80 deg. C.V.
Shear Bolt	3/8 x 2" Fine Thread Gr. 5
Rated PTO RPM	1000 RPM
Flail Tip Speed at 1000 RPM	7000 FPM
Number of Flails	28
Flail Size	3/4 x 1-1/2 x 7 in.
Flail Bushing	Oil Impregnated Brass
Rotor Shaft	1-15/16" Bearing
Gearbox Oil	GL5 80W90
Gearbox Oil Capacity	500 mL

Hydraulics:

Required Remotes	3 Standard 2 Optional 4 Optional (5300TR, 5300X or 5300XTR)
Minimum Flow Requirements	15 GPM
Minimum Pressure Requirements	1800 psi

Other:

Agitator Shaft	1-3/4" Bearings
Twine Guards	Rotor, Agitators, Axles
Adjustable Bale Fork Width (on centers)	48 in. or 40.5 in.
Adjustable Hitch Height	4 settings at 1.5 in. intervals (13" -17.5")
Discharge deflector	Adjustable top and bottom Removable rubber end flap

PARTS MANUAL

Machine Overview	39
Jack & Hitch	40
Wheels & Hub	41
Spindle	42
Rotor & Drive Components.....	43
Gearbox	44
PTO Shaft	46
Grates.....	47
Agitators	49
Rear Tub Components	50
Rear Deflector / Lights.....	50
Wing and Bale Slide.....	51
Front Rack	52
Rear Forks	54
Deflector & Hose Cover	55
Front Tub Components	59
Hose Holder and Manual Holder	60
Hose Clamps.....	62
Slow Moving Vehicle (SMV) Sign Kit	64
Lights & Harness	65
Decals	66
Three Bale Kit Option	68
Three Bale Kit Left Arm (Series 1).....	69
Three Bale Kit Lockout Mechanism (Series 1).....	71
Three Bale Kit Center (Series 1).....	73
Three Bale Kit Right Arm (Series 1).....	74
Three Bale Kit Left Arm (Series 2).....	75
Three Bale Kit Center (Series 2).....	76
Three Bale Kit Right Arm (Series 2).....	77
Total Ration Grain Tank Option.....	79
Total Ration Tank Front.....	80
Total Ration Tank Rear	82
Total Ration Cross Auger.....	84
Total Ration Tank Lid.....	86
Fine Chop Option	87
Twine Cutter Option	89
Back-up Camera Option	90
Diverter Control Box	91
HYDRAULIC SCHEMATICS.....	95

Machine Overview

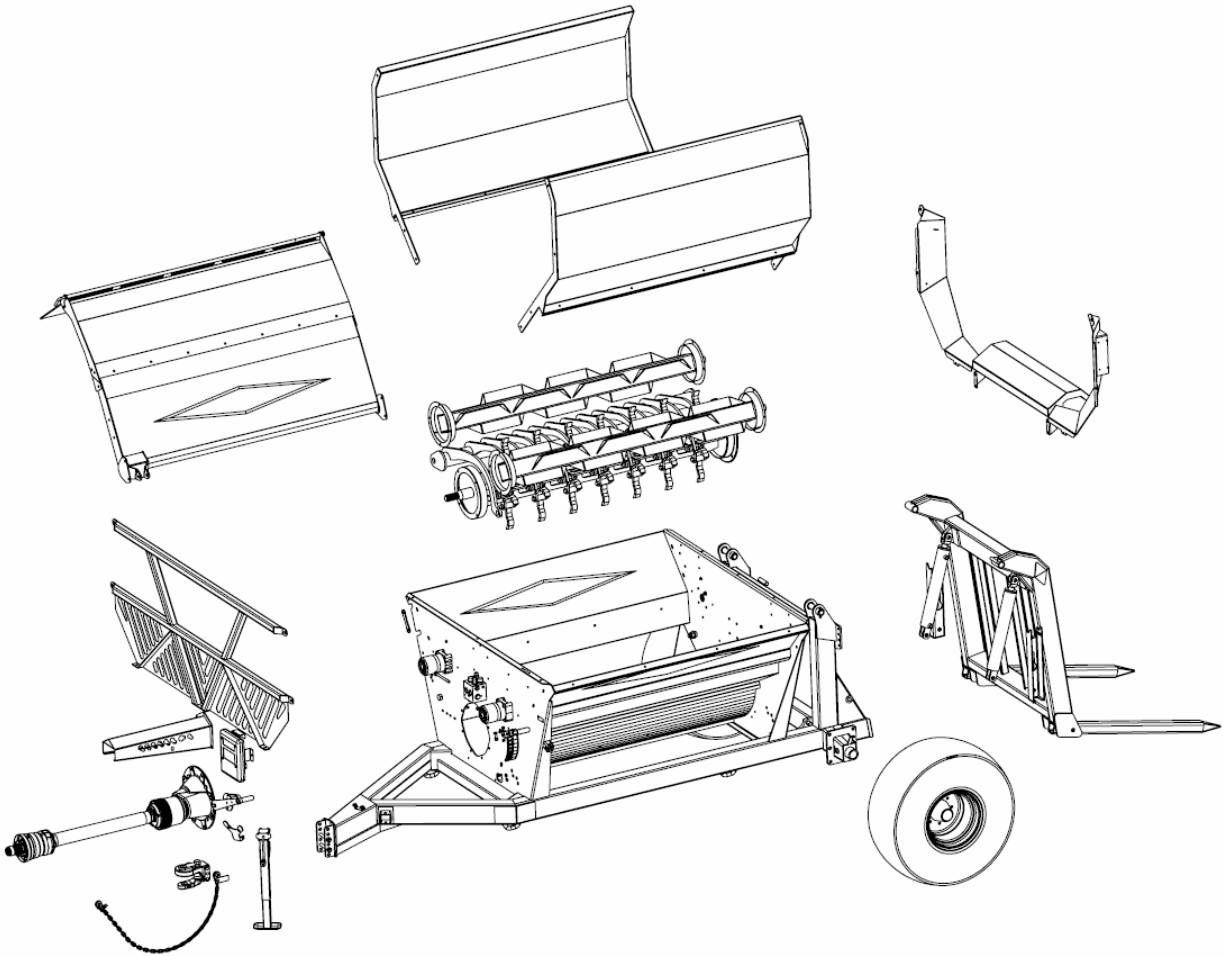

**** CHECK YOUR SERIAL NUMBER BEFORE ORDERING PARTS ****
**** PAY ATTENTION TO SERIAL NUMBER SPLITS WHERE INDICATED ****

Per Quantities: A/R = As Required
Per ID#: NSS = Not Sold Separately

Jack & Hitch

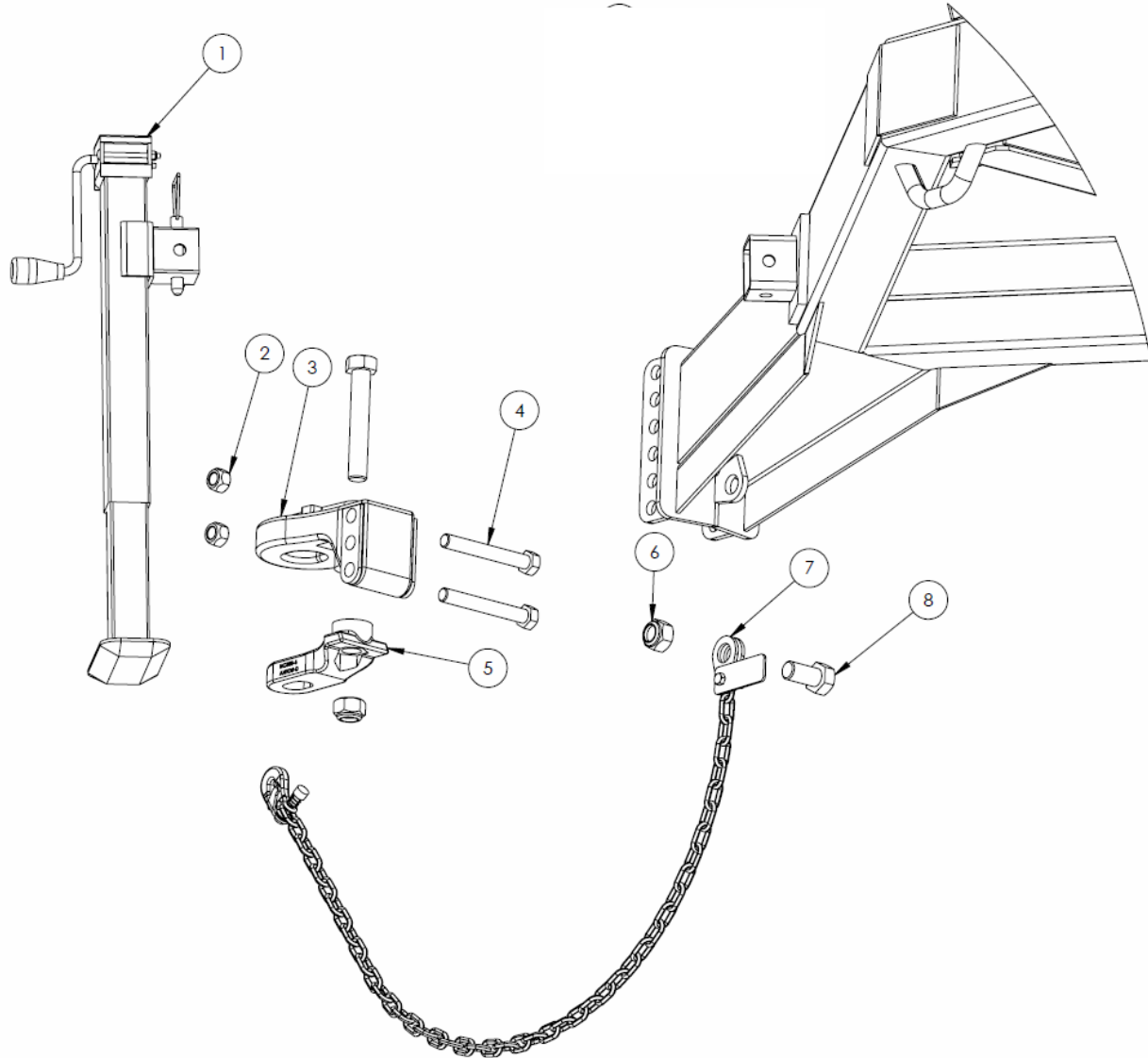

#	DESCRIPTION	PART #	QTY
1	Jack, 5000 lb	31637	1
2	Nut, 3/4" Stover Lock	11823	2
3	Hitch Tongue	29785	1
4	Bolt, 3/4" x 5-3/4"	10802	2
5	Hitch Clevis Kit	29786	1
6	Nut, 1" Stover Lock	21746	1
	Nut, 1/2" Nylon Lock	10241	1
7	Safety Chain, 11000lb x 53"	21715	1
8	Bolt, 1" x 2"	18992	1
	Bolt, 1/2" x 2"	10322	1

Wheels & Hub

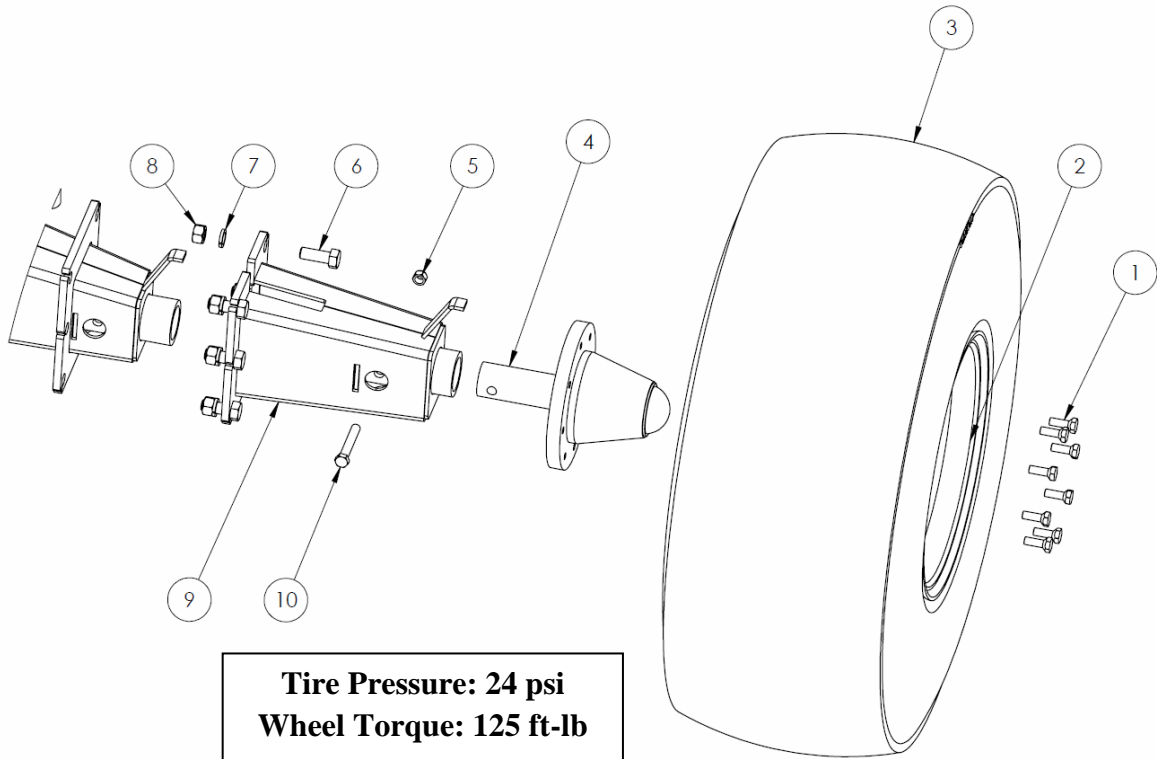

#	DESCRIPTION	PART #	QTY
1	Wheel Stud, 9/16 x 1-3/4" NF	10347	16
2	Rim, 16.1x14, 8 on 8"	10354	2
3	Tire, 16L-16.1 8 ply	See your local tire dealer	-
4	Spindle Assembly	See breakdown*	29679
5	Stover Lock Nut, 9/16"	21165	2
6	Bolt, 3/4 x 2"	13800	6
7	Lock Washer, 3/4"	13795	6
8	Nut, 3/4"	10283	6
9	Axle Extension	*TR ONLY*	30259
10	Bolt, 9/16 x 4"	33912	2

Spindle

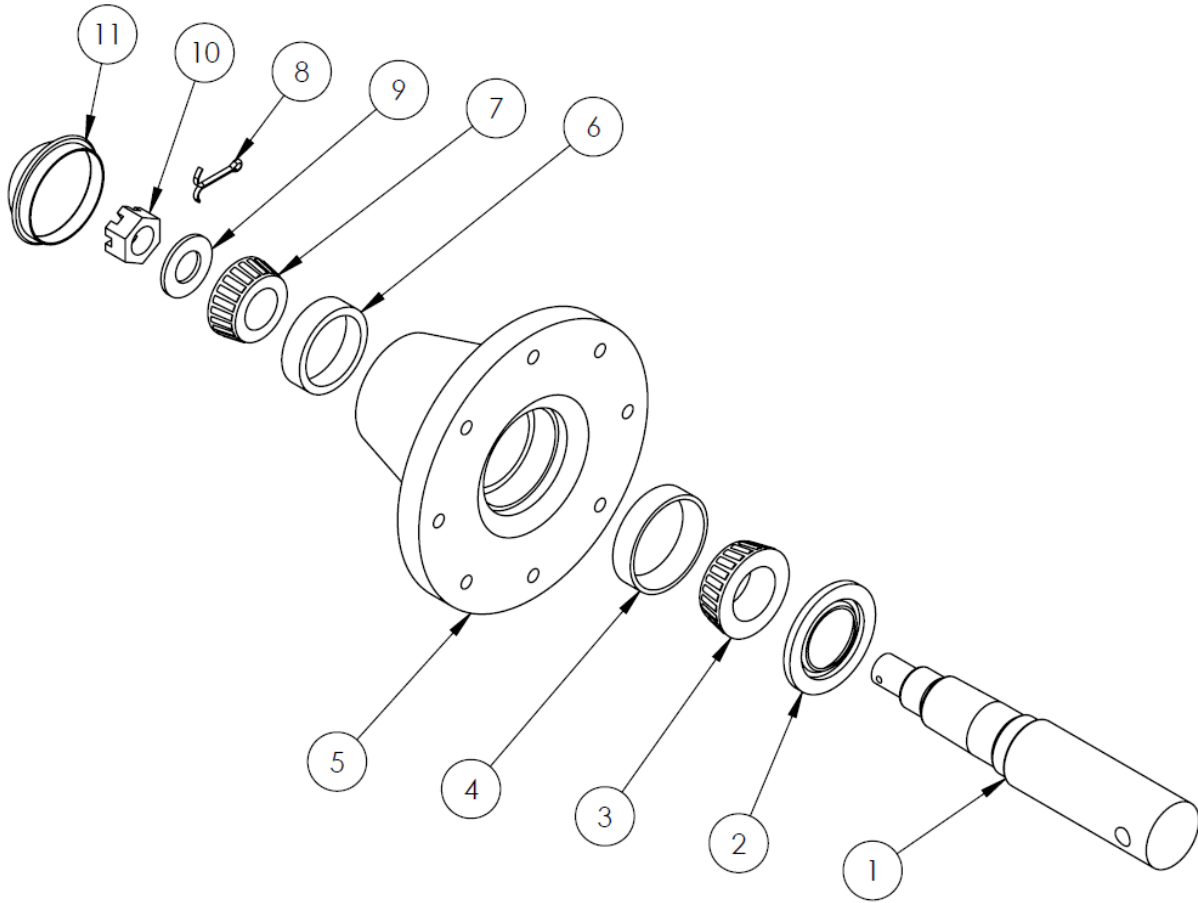

#	DESCRIPTION	PART #	QTY	
	Complete Assembly	29679	1	
1	6500lb Spindle	29730	2	
2	Seal, 2" ID	10344	2	
3	Inner Bearing Cone, 1.796" ID	LM25590	10345	2
4	Inner Bearing Race	25520	10349	2
5	Hub Housing	Includes #4 & #6	10343	2
6	Outer Bearing Race	25821	10346	2
7	Outer Bearing Cone, 1-3/8" ID	LM25877	10348	2
8	Cotter Pin, 3/16" x 1-1/2"		10072	2
9	Flat Washer, 1-1/6" ID x 2" OD		10071	2
10	Castle Nut, 1" NF		10153	2
11	Dust Cap		10350	2

Rotor & Drive Components

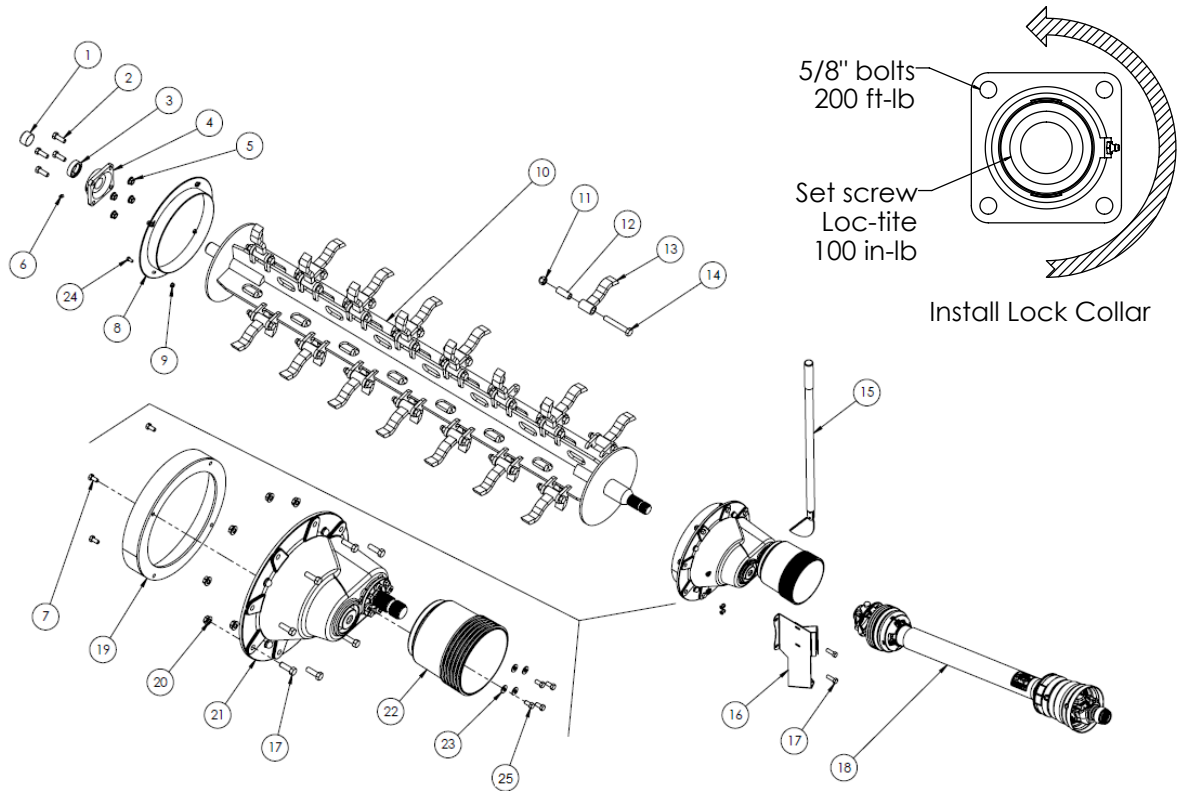

#	DESCRIPTION	PART #	QTY	
1	Rotor Shaft Cap	17380	1	
2	Bolt, 5/8" x 1-3/4" NF Gr. 8	10274	4	
3	Lock Collar	10268	1	
4	Rotor Bearing	Includes # 3 & 6	10221	1
5	Nut, 5/8" NF Serrated Flange Gr. 8	15398	4	
6	Grease Zerk, 1/8" NPT Straight	10270	1	
7	Bolt, 3/8" x 3/4"	11816	4	
8	Rotor Twine Guard, Rear	22413	1	
9	Nut, 3/8" Serrated Flange	10271	4	
10	X-Rotor Weldment	22449	1	
11	Nut, 3/4" Stover Lock	11823	28	
12	Brass Flail Bushing	10005	28	
13	Rotor Flail	22412	28	
14	Bolt, 3/4" x 4-3/4"	10443	28	
15	OPTIONAL Twine Cutter	See Breakdown	-	
16	OPTIONAL Twine Cutter Holder	See Breakdown	-	
17	Bolt, 1/2" x 1-1/2"	10174	8	
18	PTO Shaft	See Breakdown	-	
19	Gearbox Twine Guard	23002	1	
20	Nut, 1/2" Stover Lock	20154	8	
21	Gearbox Assembly	See Breakdown	-	
22	PTO Safety Shield	34899	1	
23	Flat Washer, 3/8"	11667	4	
24	Bolt, 3/8 x 1"	13806	4	
25	Bolt, M10 x 16	25154	4	

Gearbox

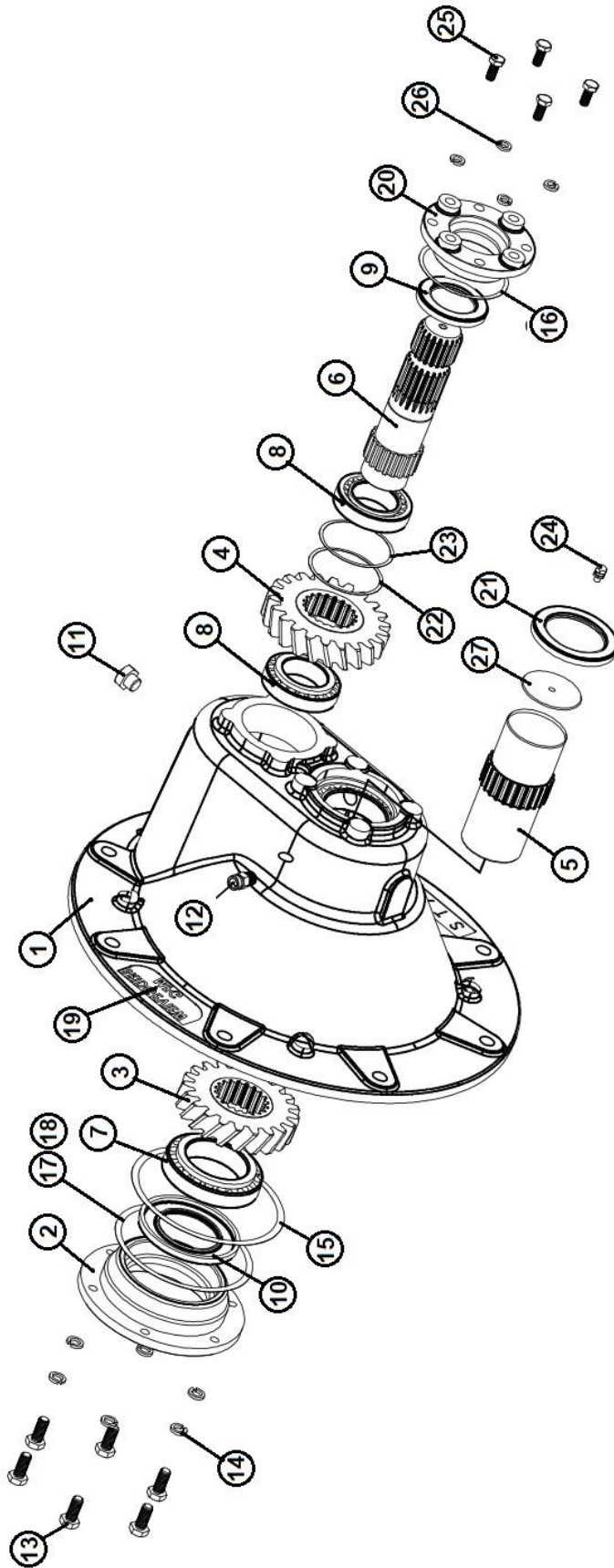

Gearbox

#	DESCRIPTION	PART #	QTY
	Complete Gearbox Assembly	22158	1
1	Housing	-	1
2	End Cap	-	1
3	Output Gear	-	1
4	Input Gear	-	1
5	Output Shaft	-	1
6	Input Shaft	-	1
7	Bearing (32012) 60mm	10496	2
8	Bearing (32009) 45mm	10497	2
9	Seal, 45 x 60 x 8	24013	1
10	Seal, 60 x 100 x 10	10498	1
11	Pipe Plug, 3/8" NPT	24014	2
12	Relief Plug, 3/8" NPT	24015	1
13	Bolt, M8 x 25 Gr. 8.8	24026	6
14	Lock Washer, M8	24016	6
15	O-Ring	24017	1
16	O-Ring	24018	1
17	Shim, 125 x 164 x 0.1	24022	2
18	Shim, 125 x 164 x 0.3	24023	2
19	Name Plate (Bridgeview)	-	1
20	End Cap	-	1
21	Seal, 60 x 85 x 10	10500	1
22	Shim, 68 x 74.5 x 0.1	24024	2
23	Shim, 68 x 74.5 x 0.3	24025	2
24	Grease Zerk, 1/4"-28 Straight	26219	1
25	Bolt, M10 x 25	15087	4
26	Lock Washer, M10	24021	4
27	Press Cup	24446	1

NOTE: Items with no part number are not sold separately. A complete gearbox is required.

PTO Shaft

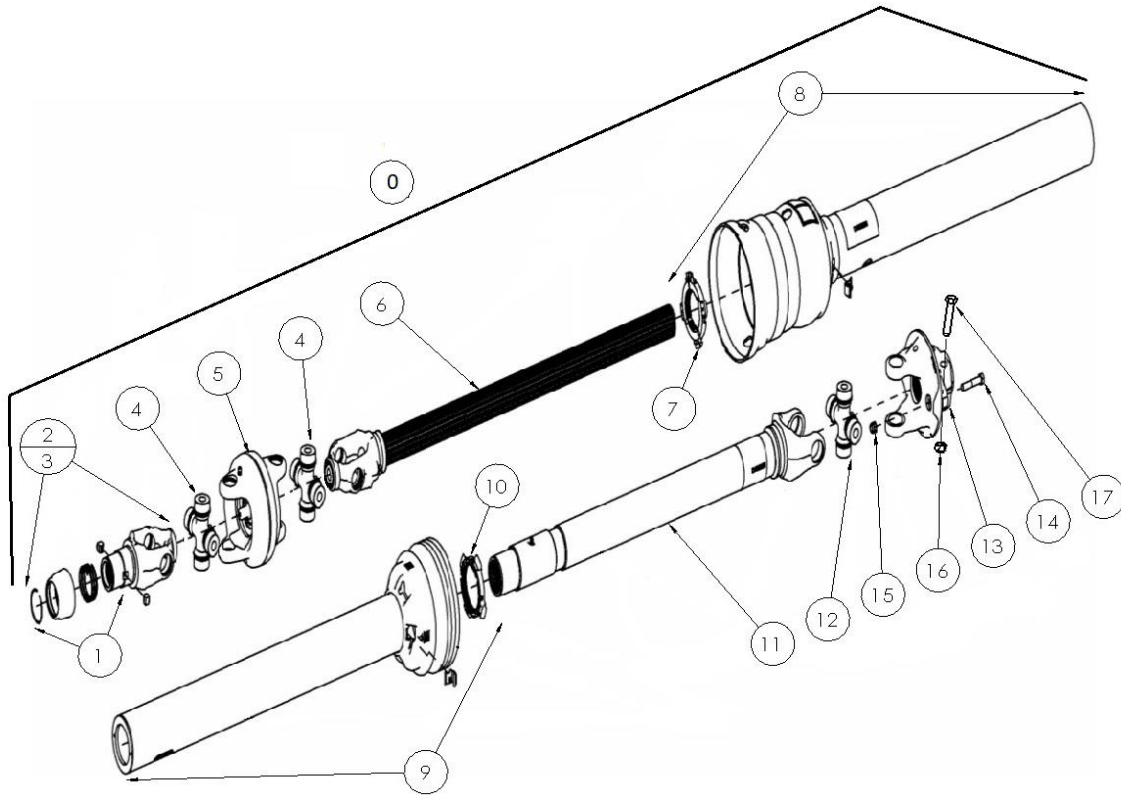

#	DESCRIPTION	PART #	QTY
	Complete PTO Shaft Assembly (1-3/8")	20546	1
0a	Tractor Half PTO Assembly (1-3/8"-21 Spline)	32505	1
0b	Tractor Half PTO Assembly (1-3/4"-20 Spline)	32506	1
1a	Safety Slide Lock Repair Kit (1-3/8"-21 Spline)	17567	1
1b	Safety Slide Lock Repair Kit (1-3/4"-20 Spline)	24981	1
2	WWCV Auto-Lok Yoke Assembly (1-3/8"-21 Spline)	20549	1
3	WWCV Auto-Lok Yoke Assembly (1-3/4"-20 Spline)	20556	
4	CV Cross and Bearing Kit (Equal Length)	20550	2
5	CV Center Housing	20551	1
6	Yoke & Shaft Assembly Tractor Side	20552	1
7	Guard Repair Kit Tractor Side	20553	1
8	Guard Assembly Tractor Side	17583	1
9	Guard Assembly Implement Side	17585	1
10	Guard Repair Kit Implement Side	17572	1
11	Yoke & Tube Assembly Implement Side	17584	1
12	U-joint Cross & Bearing Kit	17573	1
13	Shear Assembly * Does not come with bolts 14 or 17 *	29963	1
14	Shear Bolt, 3/8" x 2" Fine Thread	33285	1
15	Nut, 3/8" Fine Thread Stover Lock	33286	1
16	Nut, 5/8" Stover Lock	24982	2
17	Bolt, 5/8" x 3-1/2"	24983	2

NOTE: Ensure that the PTO shaft on the machine is correct to the drawings below. Equal length CV cross (4.19") with bearing cup diameter 1.38". If the damaged PTO has different dimensions, consult the Bridgeview Manufacturing website.

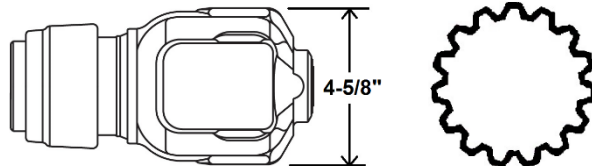

Grates

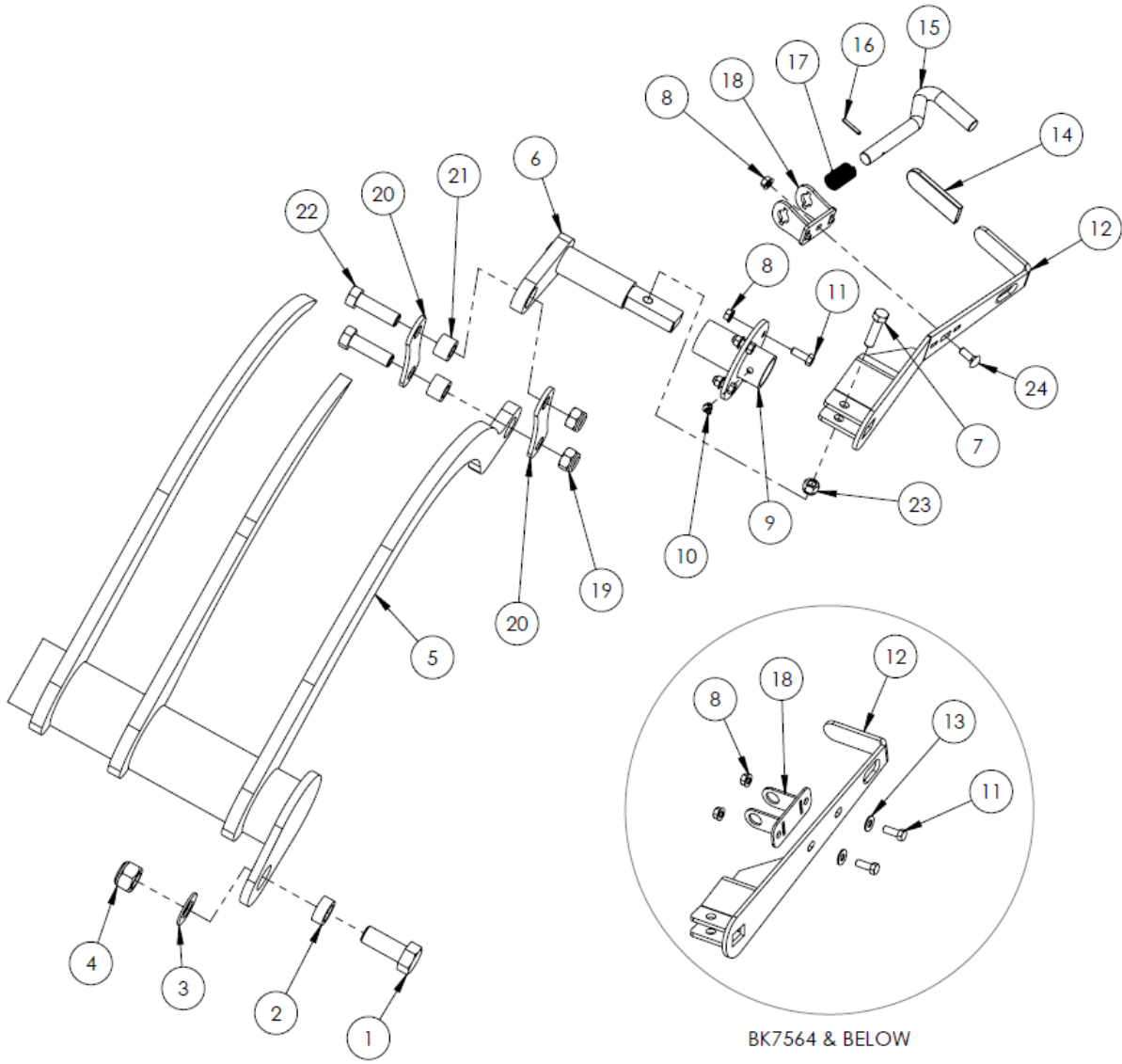

Grates

#	DESCRIPTION	PART #	QTY
1	Bolt, 1" x 2-1/2"	21820	2
2	Grate Pivot Bushing	22417	2
3	Flat Washer, 1"	14472	2
4	Nut, 1" Stover Lock	21746	2
5	Grate Assembly	29944	1
6	Grate Adjustment Cam	Includes #9,10 31720	1
7	Bolt, 1/2" x 2"	10322	1
8	Nut, 3/8" Serrated Flange	10271	5
9	Grate Handle Pivot	NSS	1
10	Grease Zerk, 1/4"-28 x 45°	20888	1
11	Bolt, 3/8" x 1"	13806	4
12	Grate Handle	Comes with #18,24,8 31725	1
13	Washer, 3/8" Flat	S/N BK7564 & below 11667	-
14	Rubber Cover	10297	1
15	S-Handle	22187	1
16	Roll Pin, 3/16" x 1-1/4"	10302	1
17	Grate Handle Spring	10301	1
18	Handle Spring Guide	S/N BK7565 & above S/N BK7564 & below 33693 31711	1
19	Nut, 3/4" Nylon Lock	10007	2
20	Grate Shackle	31709	2
21	Grate Shackle Bushing	22415	2
22	Bolt, 3/4" x 2-1/2"	14470	2
23	Nut, 1/2" Nylon Lock	10241	1
24	Bolt, 3/8 x 1" Carriage	15718	1

Agitators

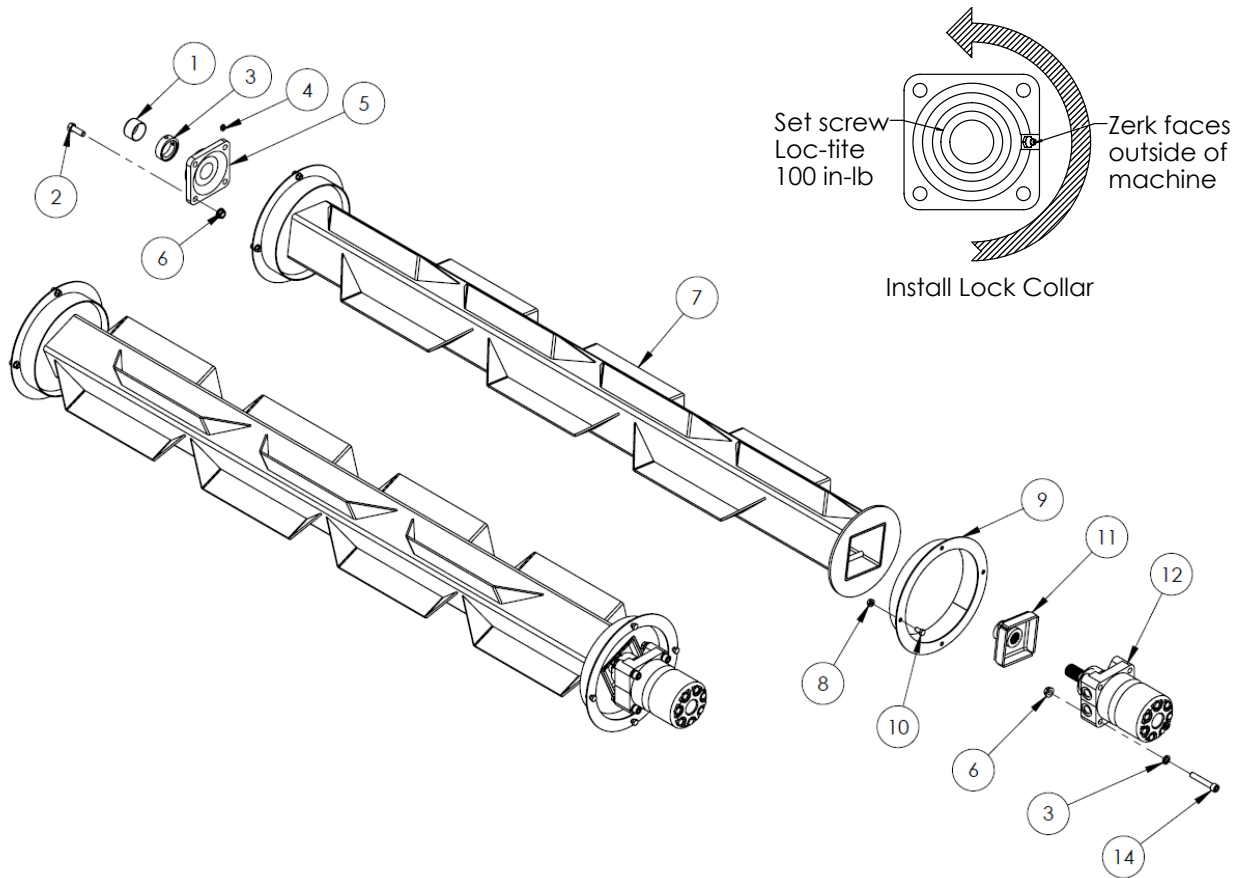

#	DESCRIPTION	PART #	QTY
1	Agitator Shaft Cap	17381	2
2	Bolt, 1/2" x 1-1/2"	10174	8
3	Lock Collar	10040	2
4	Grease Zerk, 1/8" NPT Straight	10270	2
5	Agitator Bearing	Includes # 3 & 4 10038	2
6	Nut, 1/2" Serrated Flange	10273	16
7	Agitator	31596	2
8	Nut, 3/8" Serrated Flange	10271	16
9	Agitator Twine Guard	22419	4
10	Bolt, 3/8" x 3/4"	11816	16
11	Agitator Insert	22084	2
12	Agitator Motor, 8" Long * Seal Kit	25872 25891	2
13	Lock Washer, 1/2"	14447	8
14	Socket Head Bolt, 1/2" x 3"	25952	8

Rear Tub Components

Rear Deflector / Lights

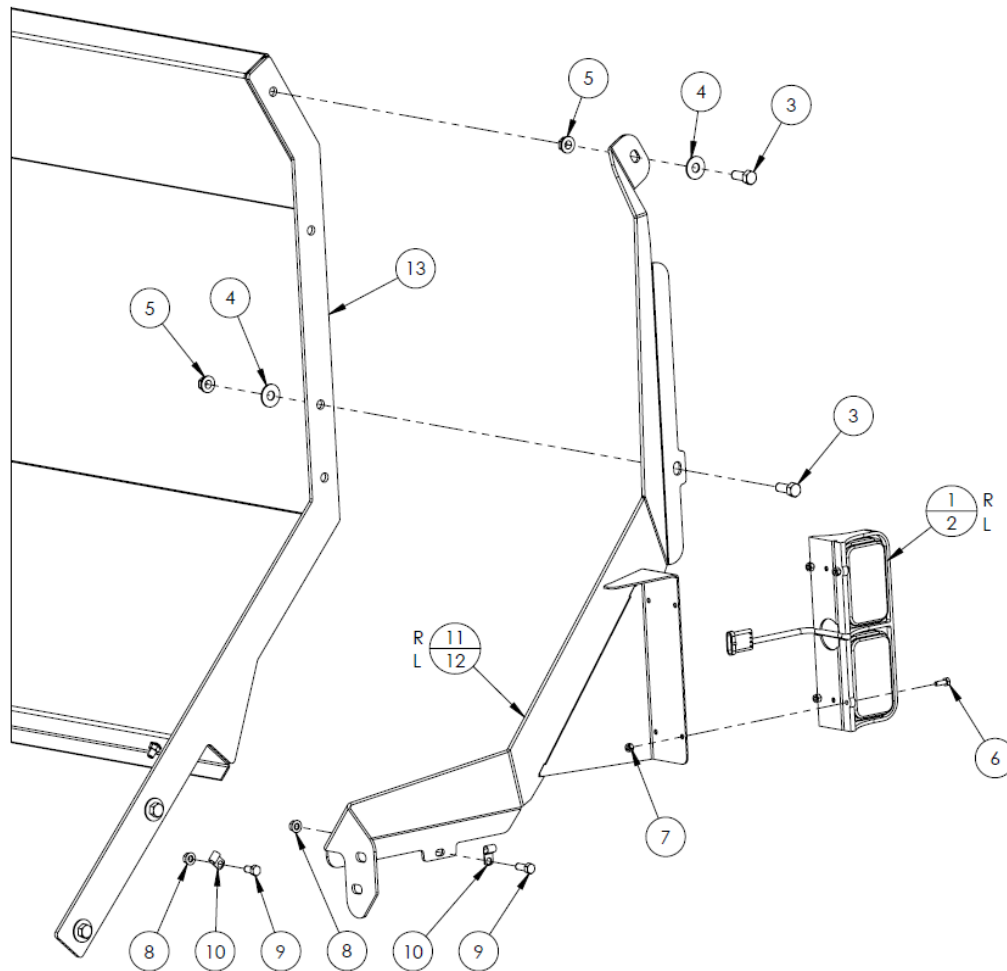

#	DESCRIPTION	PART #	QTY/ SIDE
1	Light Assembly, Right Hand	31088	1
2	Light Assembly, Left Hand	31087	1
3	Bolt, 1/2" x 1 1/4"	10240	2
4	Flat Washer, 1/2"	11668	2
5	Nut, 1/2" Serrated Flange	10273	2
6	Bolt, 1/4" x 3/4"	11809	4
7	Nut, 1/4" Nylon Lock	11664	4
8	Nut, 3/8" Serrated Flange	10271	2
9	Bolt, 3/8" x 1"	13806	2
10	Wiring Clamp	13629	2
11	Rear Deflector, Right Hand	S/N BK7254 & above 32780 S/N BK7253 & lower 31699	1
12	Rear Deflector, Left Hand	S/N BK7254 & above 32779 S/N BK7253 & lower 31695	1
13	Wing	31692	1

Wing and Bale Slide

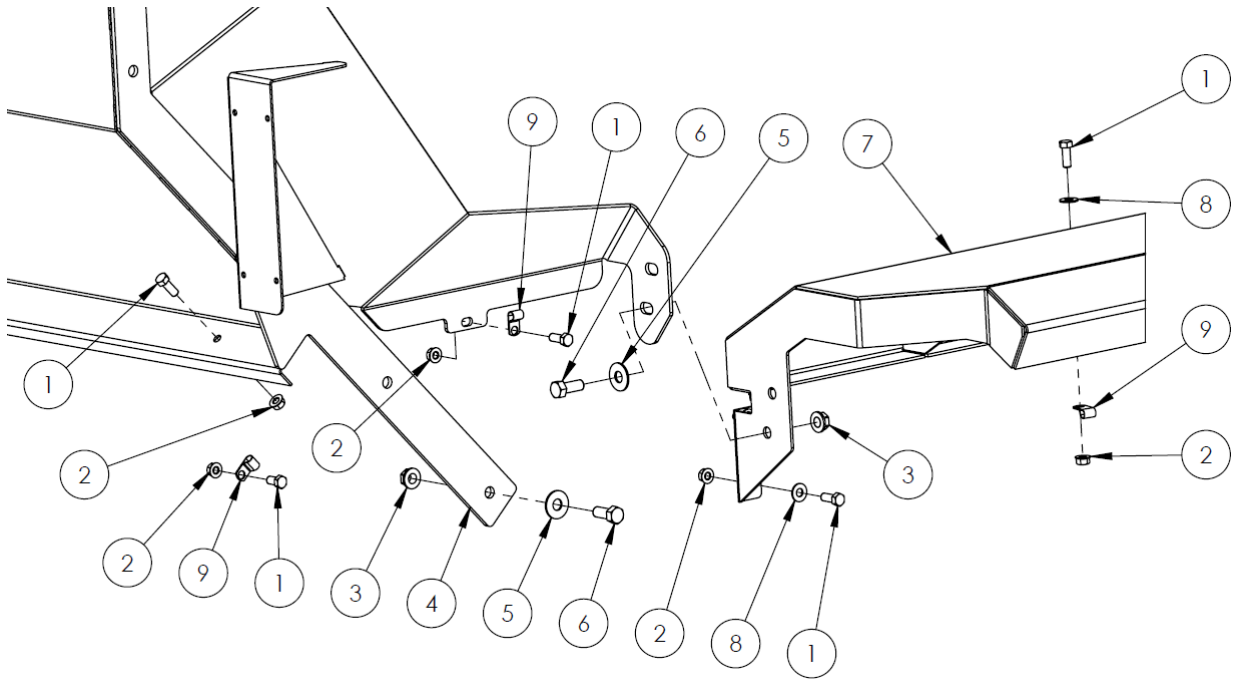

#	DESCRIPTION	PART #	QTY/ SIDE
1	Bolt, 3/8" x 1"	13806	9
2	Nut, 3/8" Serrated Flange	10271	9
3	Nut, 1/2" Serrated Flange	10273	4
4	Wing	31692	1
5	Flat Washer, 1/2"	11668	4
6	Bolt, 1/2 x 1-1/4"	10240	4
7	Bale Slide	31703	1
8	Flat Washer, 3/8"	11667	7
9	Wiring Clamp	13629	2

Front Rack

S/N BK7362 & above

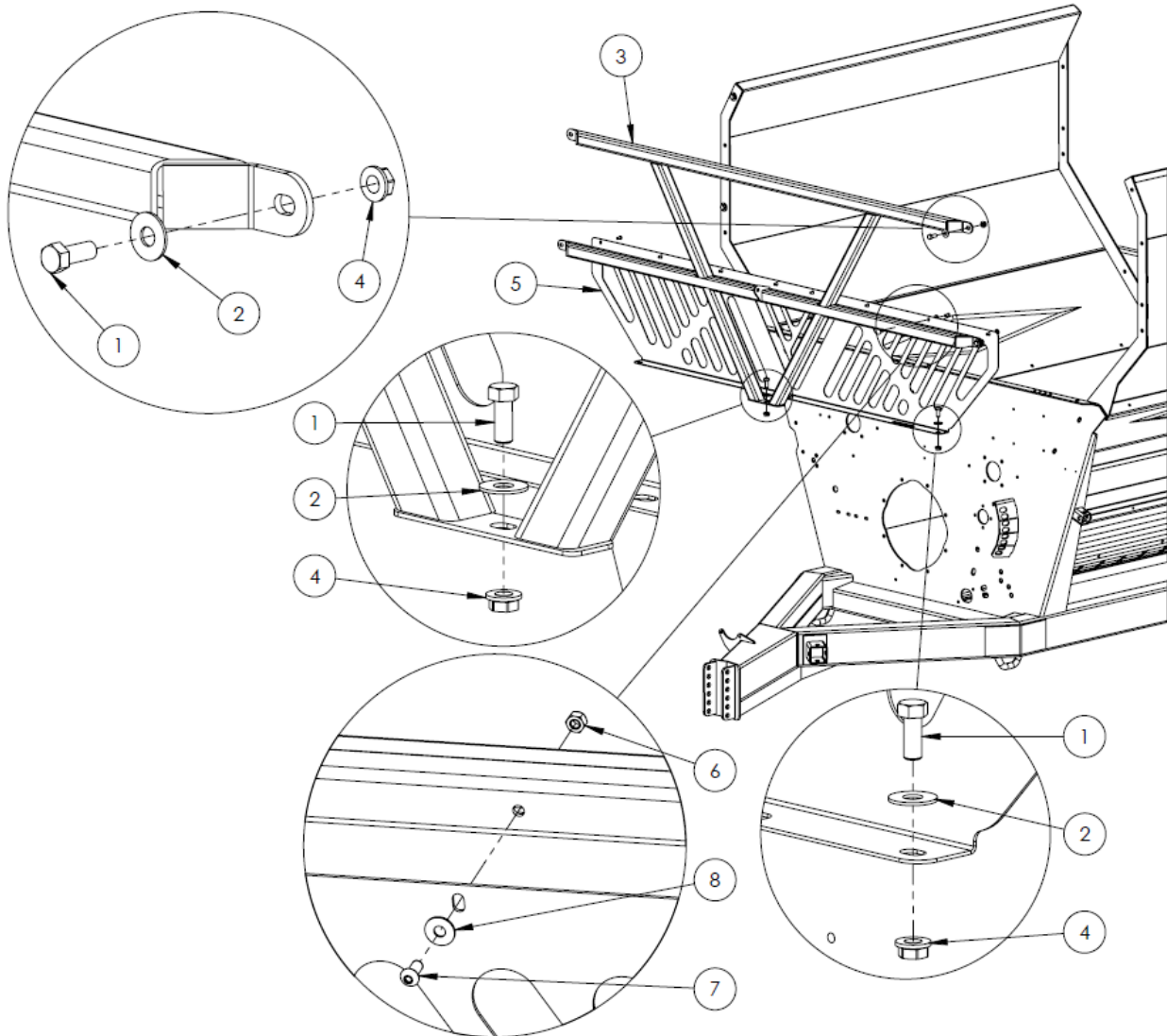

#	DESCRIPTION	PART #	QTY
1	Bolt, 1/2" x 1 1/4"	10240	7
2	Flat Washer, 1/2"	11668	7
3	Front Rack	31730	1
4	Nut, 1/2" Serrated Flange	10273	7
5	Front Rack Grating	32479	1
6	Nut, 5/16" Nylon Lock	11815	8
7	Bolt, 5/16" x 3/4" Button Head	32513	8
8	Washer, 5/16" Flat	12496	8

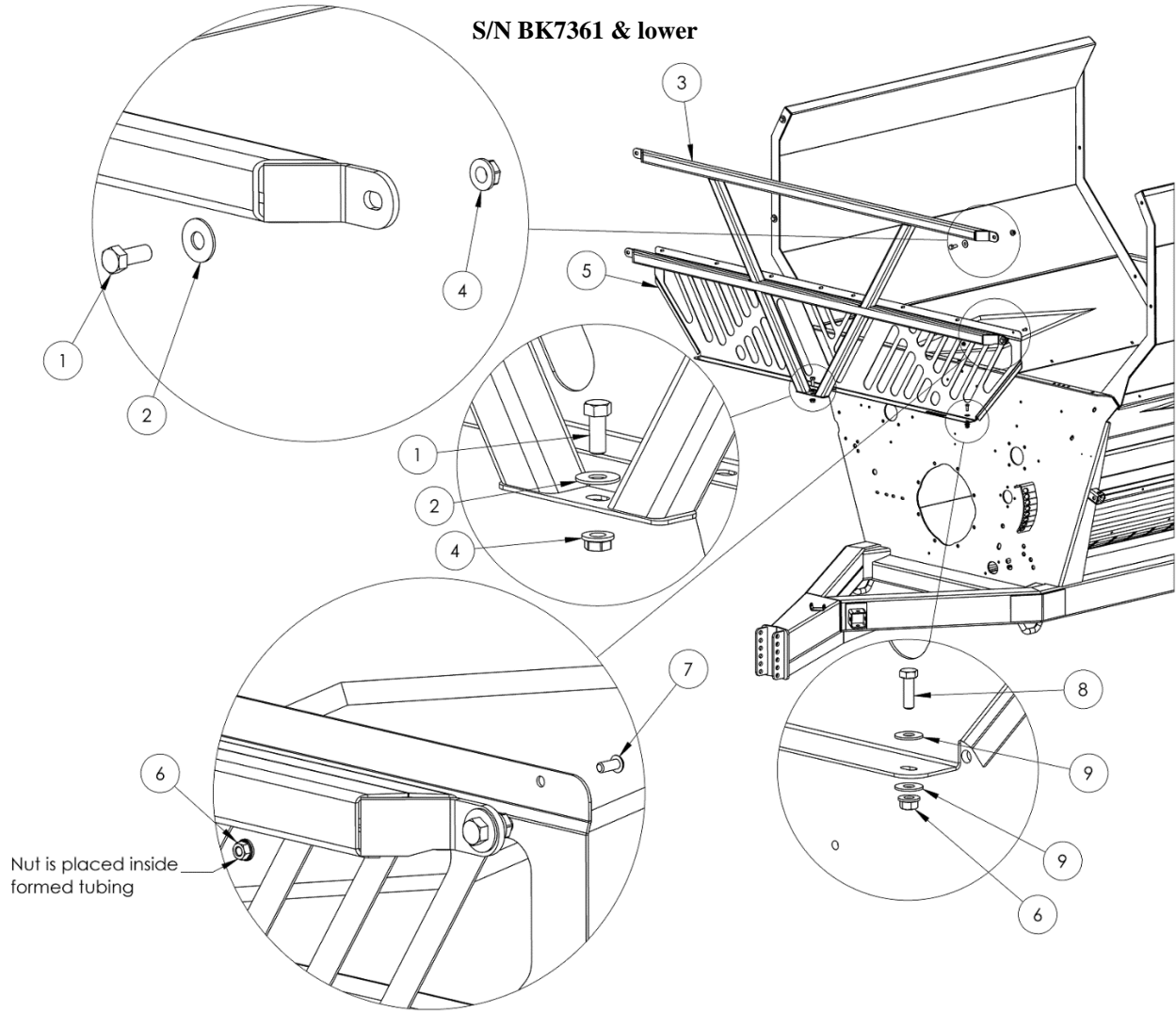

#	DESCRIPTION	PART #	QTY
1	Bolt, 1/2" x 1-1/4"	10240	5
2	Flat Washer, 1/2"	11668	5
3	Front Rack	31730	1
4	Nut, 1/2" Serrated Flange	10273	5
5	Front Rack Grating	32479	1
6	Nut, 5/16" Nylon Lock	11815	10
7	Bolt, 5/16" x 3/4" Button Head	32513	8
8	Bolt, 5/16" x 1" Bolt	20906	2
9	Flat Washer, 5/16"	15413	4

Rear Forks

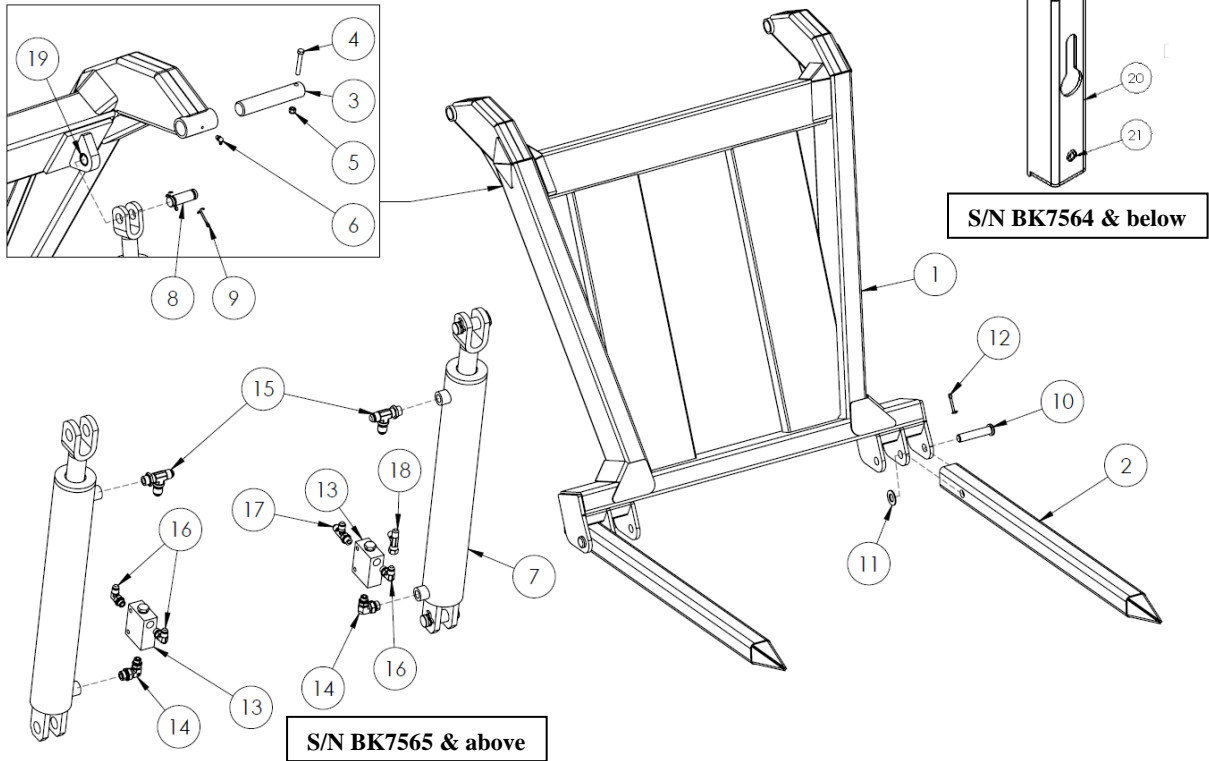

#	DESCRIPTION	PART #	QTY
1	Tapered Rear Fork Frame	S/N BK7362 & above 33759	1
	Square Rear Fork Frame	S/N BK7361 & below 31766	
2	Fork Tine	S/N BK7690 & above	2
		S/N BK7689 & below	
3	Rear Fork Pivot Pin	22006	2
4	Bolt, 3/8" x 2-3/4"	20908	2
5	Nut, 3/8" Nylon Lock	10806	2
6	Grease Zerk, 1/4" x 90°	S/N BK7362 - 7689	2
		S/N BK7159-7361, 7690 & above	
7	Hydraulic Cylinder, 3" x 18" x 1-1/2" * Seal Kit	21717	2
		20807	
8	Cylinder Pin, 1 x 3-1/2"	S/N BK7565 & above	4
		S/N BK7564 & below	
9	Cotter Pin, 3/16" x 1-1/2"	10072	8
10	Fork Tine Pin	10031	2
11	Flat Washer, 1"	14472	2
12	Cotter Pin, 1/4" x 2"	10580	2
13	Hydraulic Check Valve	19114	2
14	Hyd. Fitting, 8MB - 6MB90	33739	2
15	Hyd. Fitting, 8MBR - 8MJT	22159	2
16	Hyd. Fitting, 6MB - 6MJ90	10201	3
17	Hyd. Fitting, 6MBR - 6MJT	23726	1
18	Hyd. Fitting, 6FJXR - 6MJT	15760	1
19	Bushing Insert, 1"	23708	4
20	Cylinder Safety Lock	S/N BK7564 & below 31761	2
21	Grommet	S/N BK7564 & below 21428	2

Deflector & Hose Cover

Deflector & Hose Cover - S/N BK7169 & up

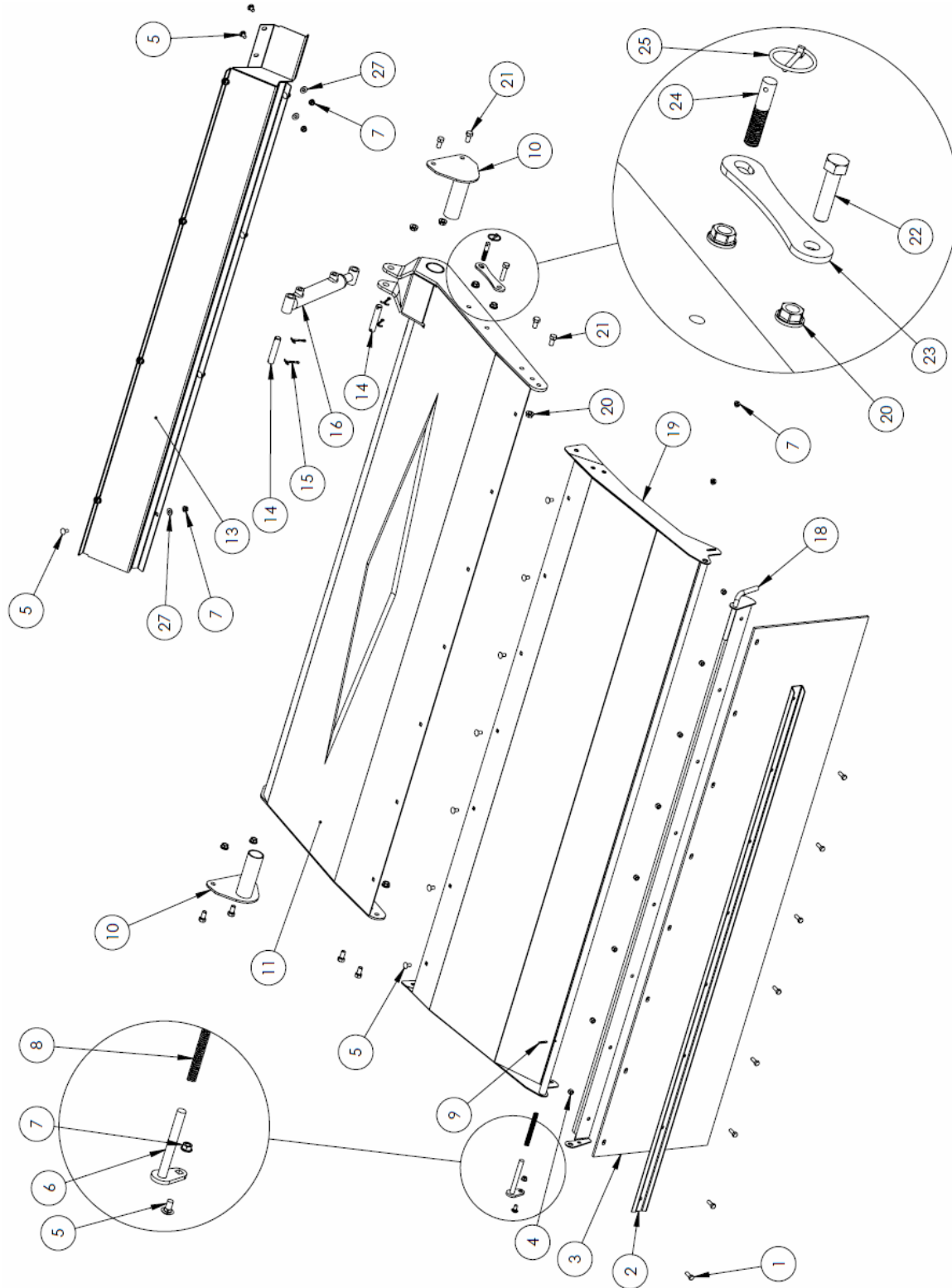

Deflector & Hose Cover - S/N BK7169 & up

#	DESCRIPTION	PART #	QTY
1	Bolt, 3/8" x 1"	13806	8
2	Deflector Rubber Channel	22423	1
3	Deflector Rubber	10477	1
4	Nut, 3/8" Nylon Lock	10806	8
5	Carriage Bolt, 3/8" x 3/4"	14072	18
6	Deflector Flipper Pin	24464	1
7	Nut, 3/8" Serrated Flange	10271	18
8	Compression Spring	24461	1
9	Roll Pin, 3/16" x 1-1/4"	10302	1
10	Deflector Pivot	22426	2
11	Inner Deflector	32196	1
13	Hose Cover	32191	1
14	Cylinder Pin, 3/4" x 3" Usable	22007	2
15	Cotter Pin, 3/16" x 1-1/4"	11669	4
16	Hydraulic Cylinder, 1-1/2" x 6" x 1" * Seal Kit	21711 23738	1
18	Deflector Rubber Flipper	24463	1
19	Outer Deflector	31754	1
20	Nut, 1/2" Serrated Flange	10273	12
21	Bolt, 1/2" x 1"	10824	8
22	Bolt, 1/2" x 2"	10322	1
23	Deflector Lock	22422	1
24	Pin Stud	13231	1
25	Lynch Pin	13233	1
27	Flat Washer, 3/8"	11667	10

S/N BK7168 & Down

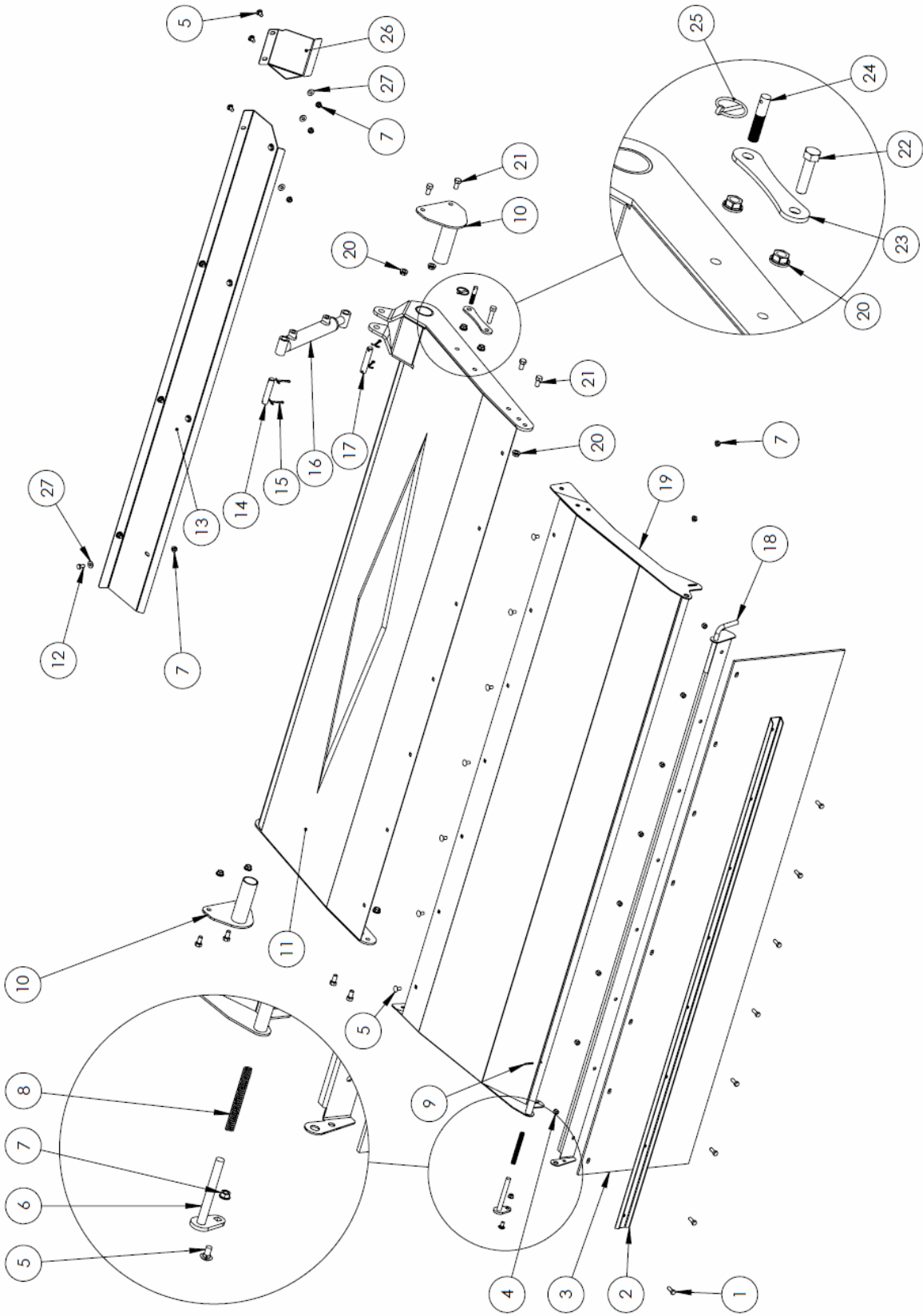

Deflector & Hose Cover - S/N BK7168 & Down

#	DESCRIPTION	PART #	QTY
1	Bolt, 3/8" x 1"	13806	8
2	Deflector Rubber Channel	22423	1
3	Deflector Rubber	10477	1
4	Nut, 3/8" Nylon Lock	10806	8
5	Carriage Bolt, 3/8" x 3/4"	14072	14
6	Deflector Flipper Pin	24464	1
7	Nut, 3/8" Serrated Flange	10271	18
8	Compression Spring	24461	1
9	Roll Pin, 3/16" x 1-1/4"	10302	1
10	Deflector Pivot	22426	2
11	Inner Deflector	31749	1
12	Bolt, 3/8" x 3/4"	11816	4
13	Hose Cover	22436	1
14	Cylinder Pin, 3/4" x 3" Usable	22007	1
15	Cotter Pin, 3/16" x 1-1/4"	11669	4
16	Hydraulic Cylinder, 1-1/2" x 6" x 1" * Seal Kit	21711 23738	1
17	Cylinder Pin, 3/4" x 3" Usable	22007	1
18	Deflector Rubber Flipper	24463	1
19	Outer Deflector	31754	1
20	Nut, 1/2" Serrated Flange	10273	12
21	Bolt, 1/2" x 1"	10824	8
22	Bolt, 1/2" x 2"	10322	1
23	Deflector Lock	22422	1
24	Pin Stud	13231	1
25	Lynch Pin	13233	1
26	Hose Cover Front	22945	1
27	Flat Washer, 3/8"	11667	10

Front Tub Components

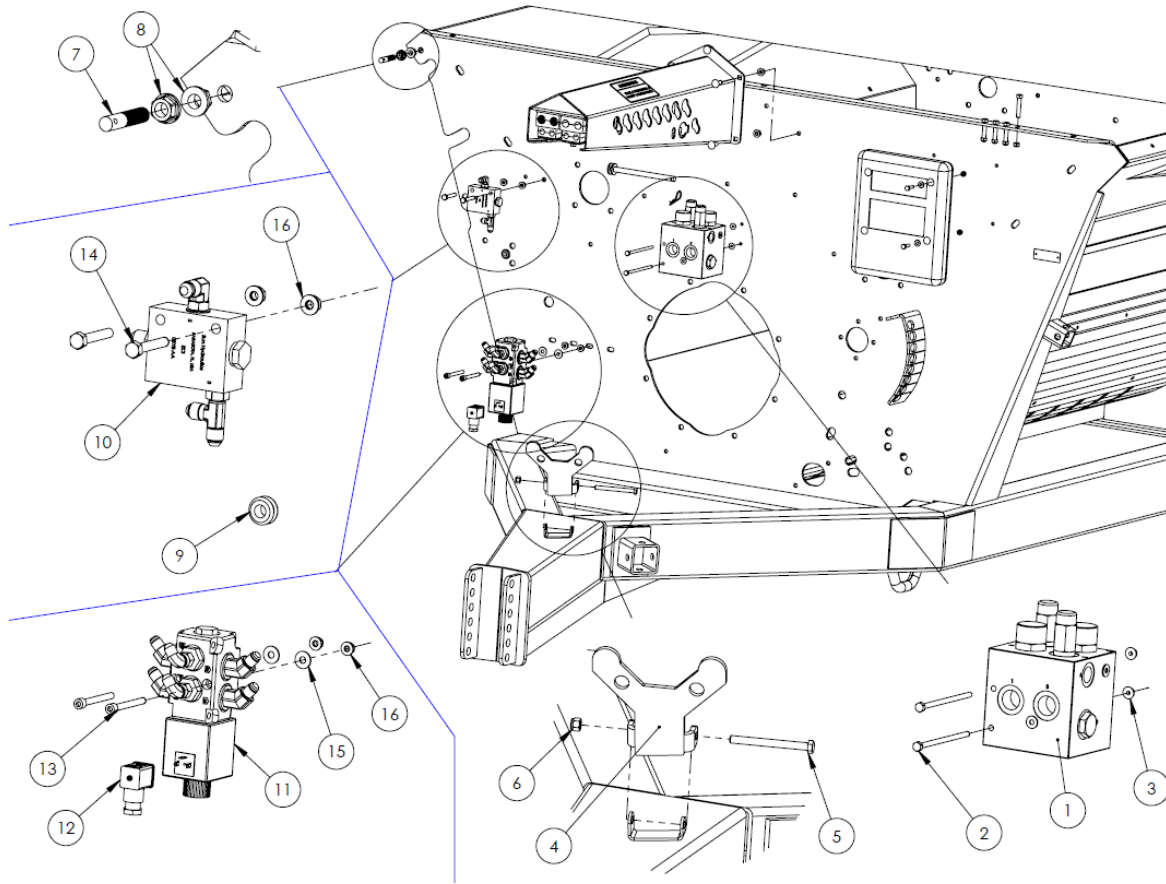

#	DESCRIPTION	PART #	QTY
1	Flow Divider Valve	25778	1
2	Bolt, 1/4 x 5"	25951	2
3	Nut, 1/4" Nylon Lock	11664	2
4	PTO Cradle	S/N BK7564 & below 31760	1
5	Bolt, 3/8 x 4"	S/N BK7564 & below 14379	1
6	Nut, 3/8" Nylon Lock	S/N BK7564 & below 10806	1
7	Threaded Pin	13231	1
8	Nut, 1/2" Serrated Flange	10273	2
9	Grommet	21428	2
10	Pilot Check Valve	19114	
11	Diverter Valve #	11743	1
	* Double Stack Kit	12895	
	* Triple Stack Kit	12897	
	* Nut & O-Ring Kit	17977	
	* Magnet Kit	11798	
12	Valve Plug	One per valve. Harness sold separately. 13657	-
13	Bolt, 5/16 x 3" Socket Head	11783	2
14	Bolt, 5/16 x 2"	15572	2
15	Washer, 5/16" Flat	12496	2
16	Nut, 5/16" Nylon Lock	11815	4

NOTE: See page 91 for information on the control box

Hose Holder and Manual Holder

S/N BK7565 & above

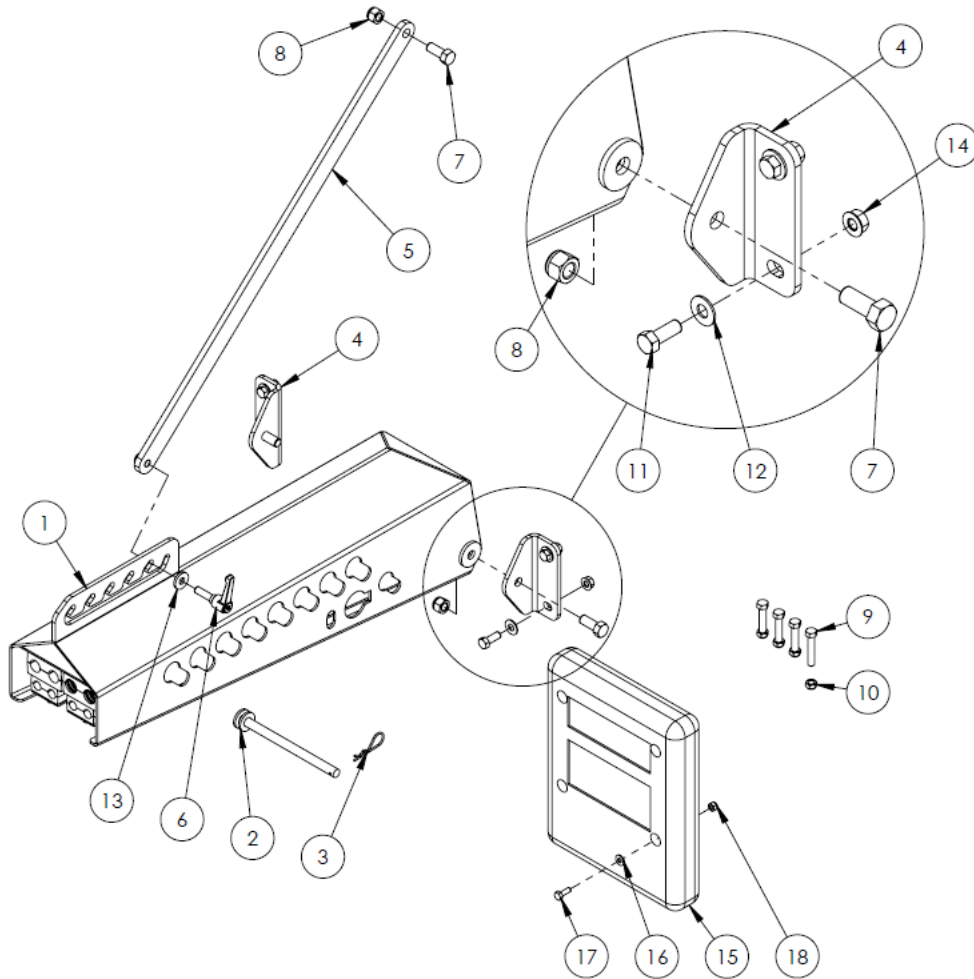

#	DESCRIPTION	PART #	QTY
1	Adjustable Hose Holder	35038	1
2	Hose Holder Pin	31745	1
3	Hairpin, 3/32 x 5/8"	11786	1
4	Hose Holder Pivot Bracket	35041	2
5	Hose Holder Linkage	35040	1
6	Threaded Adjustable Handle	34944	1
7	Bolt, 1/2 x 1-1/4"	10240	3
8	Nut, 1/2" Nylon Lock	10241	3
9	Shear Bolt, 3/8" x 2" Fine Thread Gr. 5	33285	4
10	Nut, 3/8" Fine Thread Stover Lock	33286	4
11	Bolt, 3/8" x 1"	13806	4
12	Flat Washer, 3/8"	11667	4
13	Flat Washer, 3/8" Heavy	33189	1
14	Nut, 3/8" Serrated Flange	10271	4
15	Operator Manual Holder	22409	1
16	Flat Washer, 1/4"	11666	4
17	Bolt, 1/4" x 3/4"	11809	4
18	Nut, 1/4" Nylon Lock	11664	4

S/N BK7564 & below

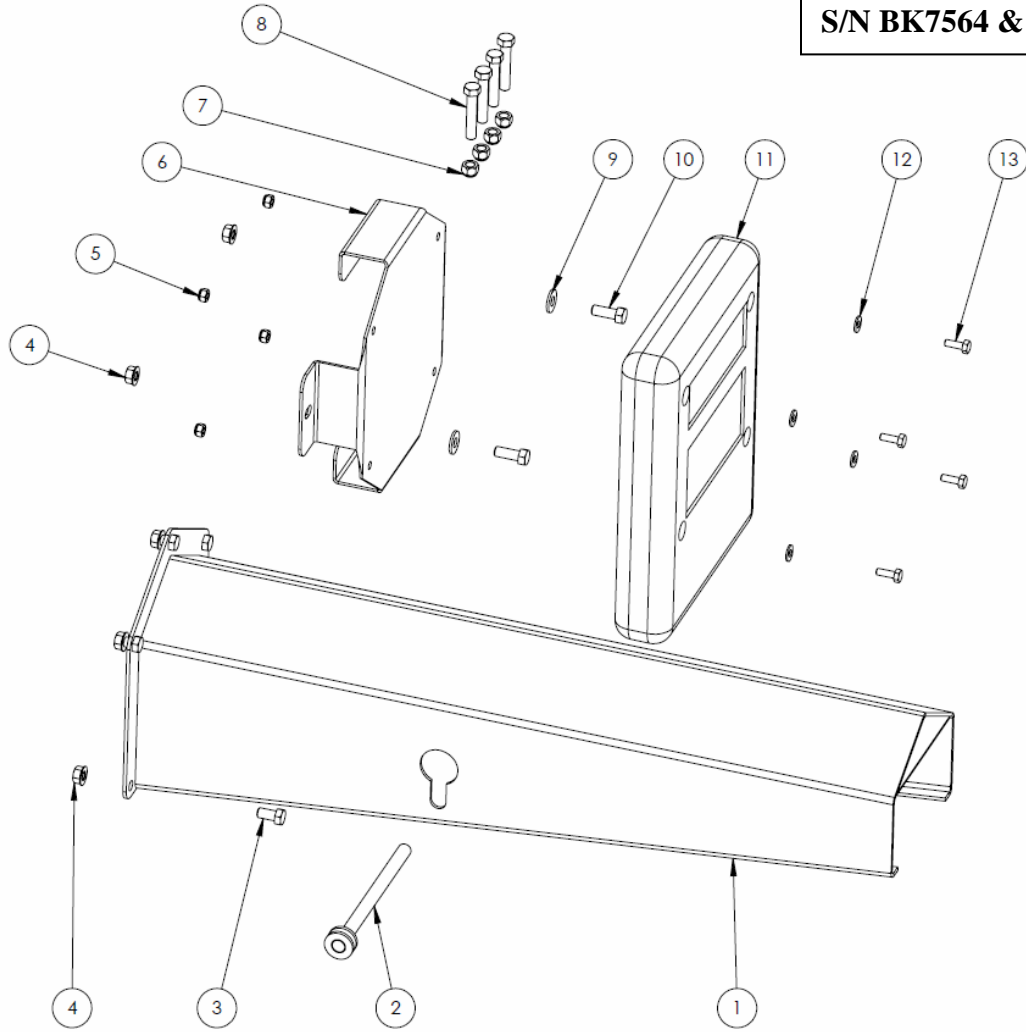

#	DESCRIPTION	PART #	QTY
1	Hose Holder	31740	1
2	Hose Holder Pin Hairpin, 3/32 x 5/8"	31745 11786	1 1
3	Bolt, Carriage 3/8" x 1"	15718	5
4	Nut, 3/8" Serrated Flange	10271	7
5	Nut, 1/4" Nylon Lock	11664	4
6	Manual Holder Bracket	S/N BK7361 & below 31781	1
7	Nut, 3/8" Fine Thread Stover Lock	33286	4
8	Shear Bolt, 3/8" x 2" Fine Thread Gr. 5	33285	4
9	Flat Washer, 3/8"	11667	2
10	Bolt, 3/8" x 1"	13806	2
11	Operator Manual Holder	22409	1
12	Flat Washer, 1/4"	11666	4
13	Bolt, 1/4" x 3/4"	11809	4

Hose Clamps

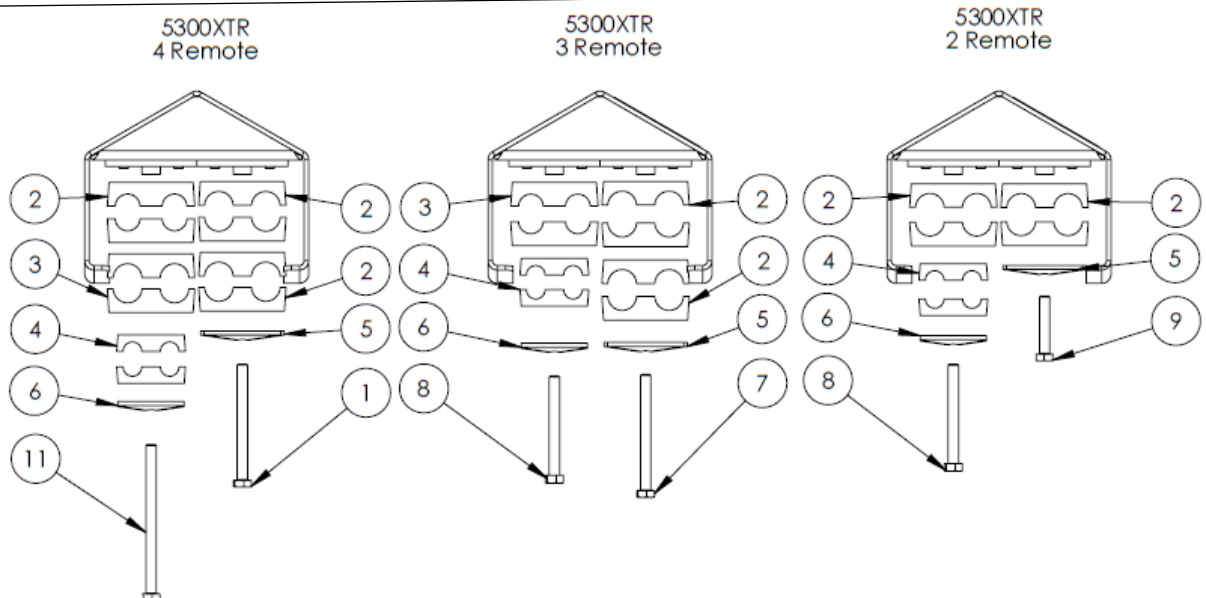
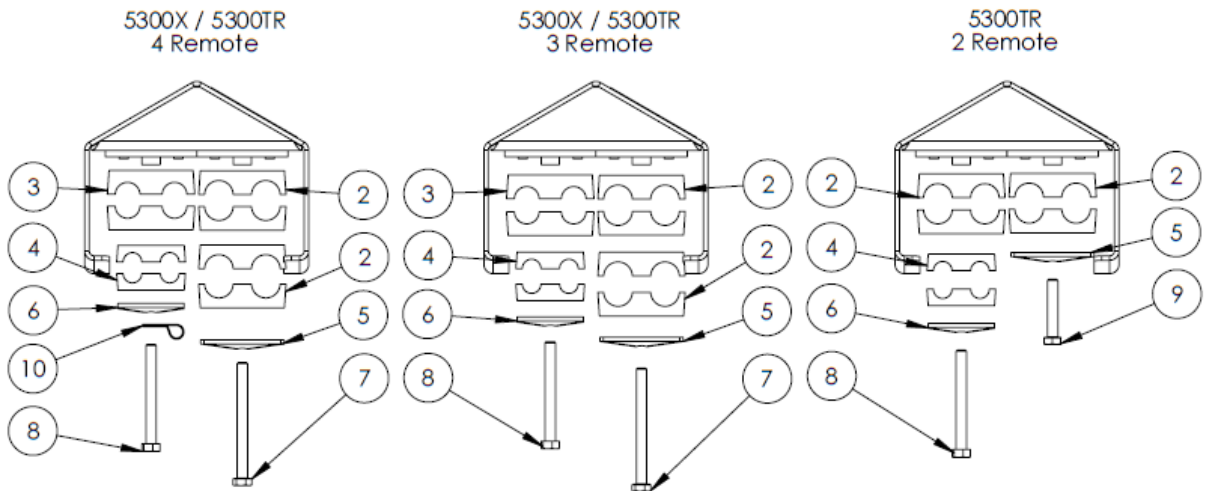
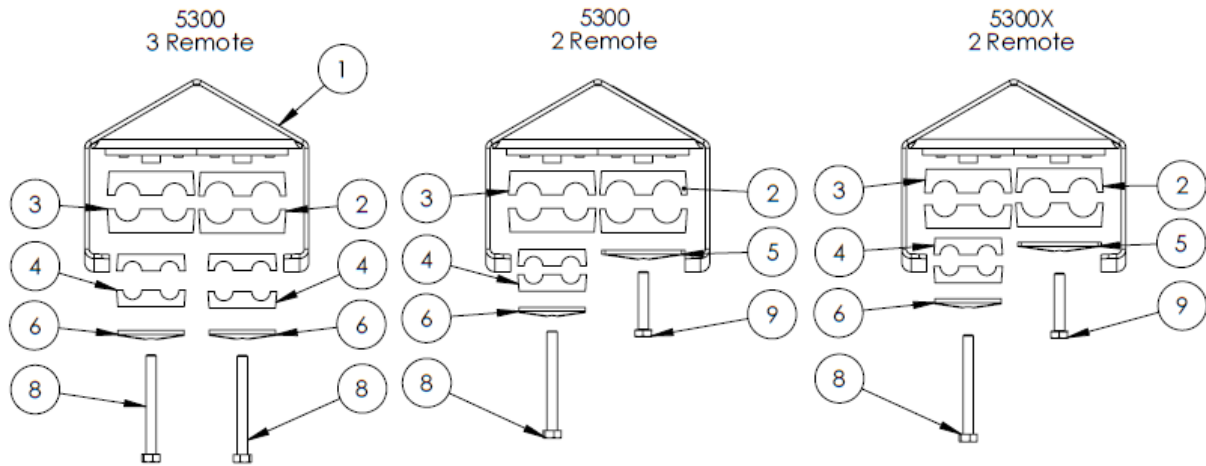

Hose Clamps...continued

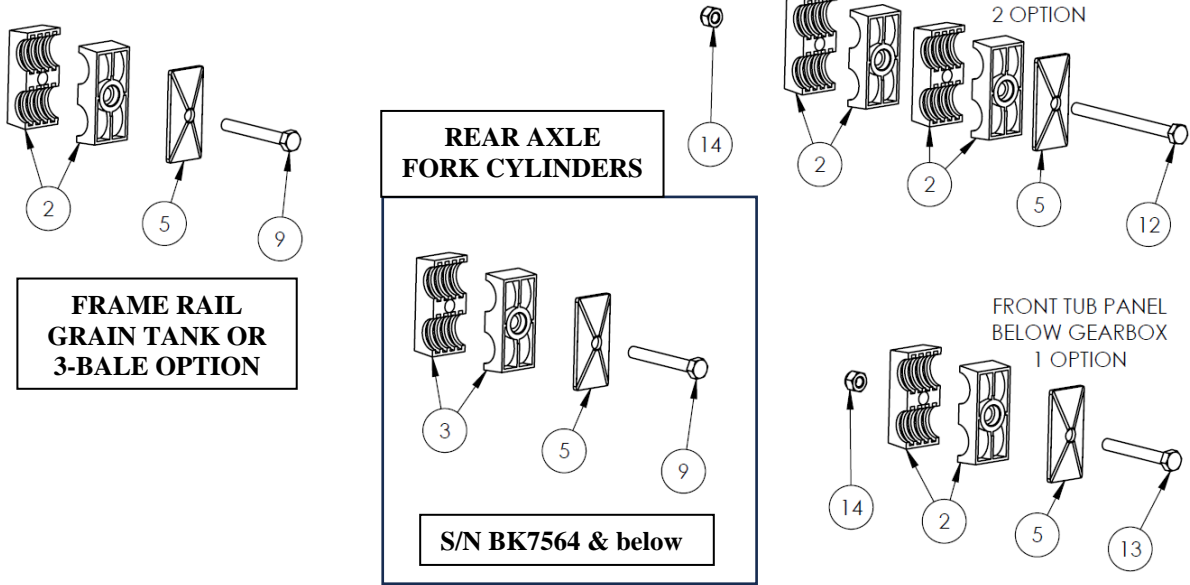

#	DESCRIPTION	PART #
1	Hose Holder	31740
2	Hydraulic Hose Clamp, 1/2"	21561
3	Hydraulic Hose Clamp, 3/8"	22180
4	Hydraulic Hose Clamp, 1/4"	22181
5	Hydraulic Hose Clamp Cap, Large	21725
6	Hydraulic Hose Clamp Cap, Small	22182
7	Bolt, 5/16" x 3-1/2"	13765
8	Bolt, 5/16" x 3"	22844
9	Bolt, 5/16" x 1-3/4"	21726
10	Wiring Clamp	13629
11	Bolt, 5/16" x 4-1/2"	21836
12	Bolt, 5/16 x 4"	31837
13	Bolt, 5/16 x 2-1/2"	19115
14	Nut, 5/16" Nylon Lock	11815

NOTE: Quantities are as required

Slow Moving Vehicle (SMV) Sign Kit

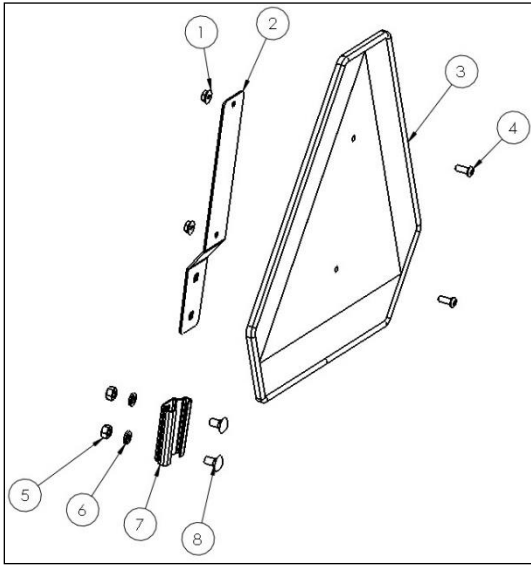

S/N BK7361 & below

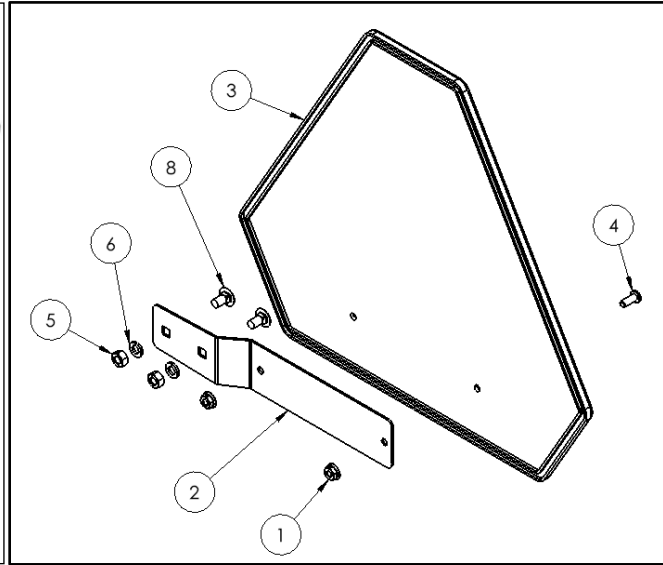

S/N BK7362 & above

NOTE: Only the parts shown above are used on the Bale King 5300. Additional parts are included in the SMV sign kit which are not required.

#	DESCRIPTION	PART #	QTY
	Complete SMV Sign Kit	22411	1
1	Nut, 1/4" Nylon Lock	11664	2
2	Galvanized Sign Bracket	-	1
3	Plastic SMV Sign	-	1
4	Pan Head Bolt, 1/4" x 5/8"	-	2
5	Nut, 5/16"	-	2
6	Lock Washer, 5/16"	-	2
7	Galvanized Tapered Receiver Bracket	-	1
8	Carriage Bolt, 5/16" x 1/2"	-	2
9	Carriage Bolt, 5/16" x 2"	-	-
10	Lock Washer, 1/4"	-	-

Lights & Harness



Decals

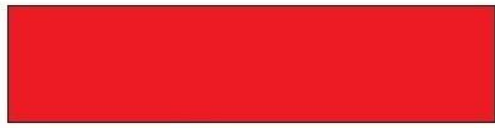
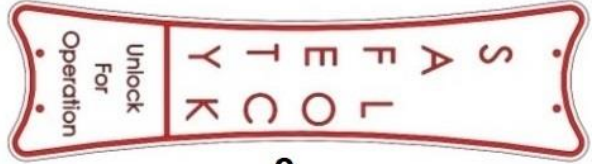

12



DECALS

#	DESCRIPTION	PART #	QTY
1	“BALE KING”	32804	2
	“5300”	31657	2
2	“DANGER”, PTO	12219	2
3	“DANGER”, Discharge	12230	4
4	“DANGER”, Stand Clear of Lift	12229	1
5	AMC Member	12239	1
6	FEMA Member	25347	1
7	Wheel Torque Reminder	28385	2
8	Deflector Safety Lock	22292	1
9	Red Reflector	28383	1
10	Amber Reflector	28384	4
11	Hoop Adjustment	32782	
12	Total Ration **TR Only**	24862	1
13	Speed Limit Decal	33159	
14(a)	Hyd. Decal (2 Remote Machine)	33138	1
14(b)	Hyd. Decal (0 Option, 3 Remote Machine)	33137	
14(c)	Hyd. Decal (1 Option, 3 Remote Machine)	33139	
14(d)	Hyd. Decal (2 Option, 3 Remote Machine)	33141	
14(e)	Hyd. Decal (1 Option, 4 Remote Machine)	33140	
14(f)	Hyd. Decal (2 Option, 4 Remote Machine)	33142	

***NOTE: Options refer to either the Three Bale Kit, or Total Ration Grain Tank Kit**

Three Bale Kit Option

Two different versions of the three bale kit have been produced. Check the serial number of your machine to determine which version to order. The primary difference is the lockout mechanism, though most other parts different.

Serial Number	Three Bale Kit	Lockout Mechanism
BK7361 & lower	Series 1	2 Valves Non-Discharge Side
BK7362 & above	Series 2	Single Valve Discharge Side

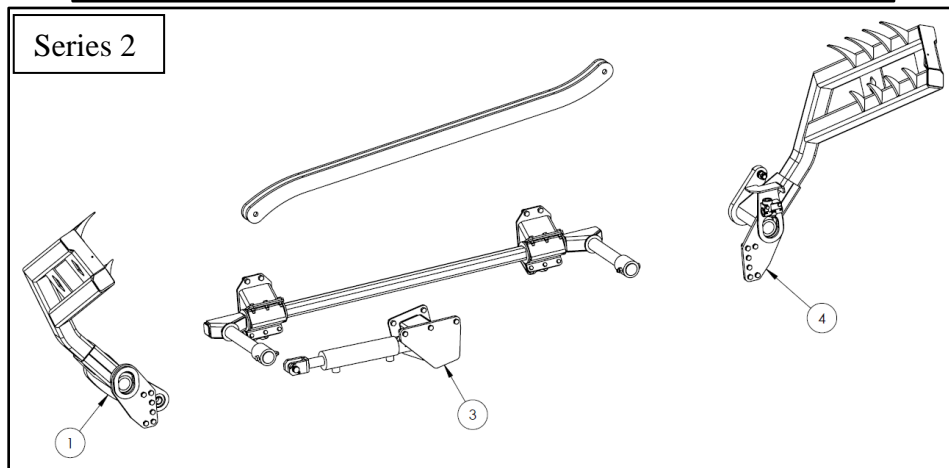
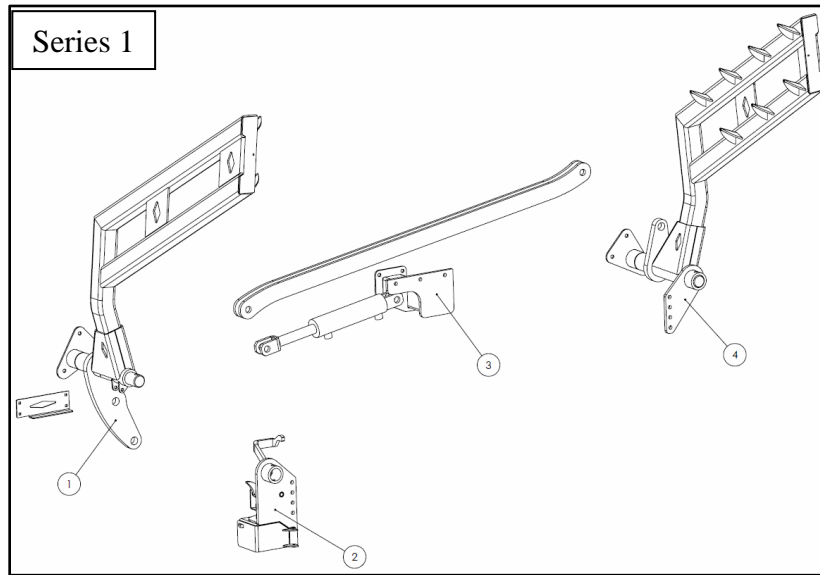

Item #	Description	Series 1	Series 2
1	Left Arm	Page 69	Page 75
2	Lockout Mechanism	Page 71	-
3	Center	Page 73	Page 75
4	Right Arm	Page 74	Page 77

Three Bale Kit Left Arm (Series 1)

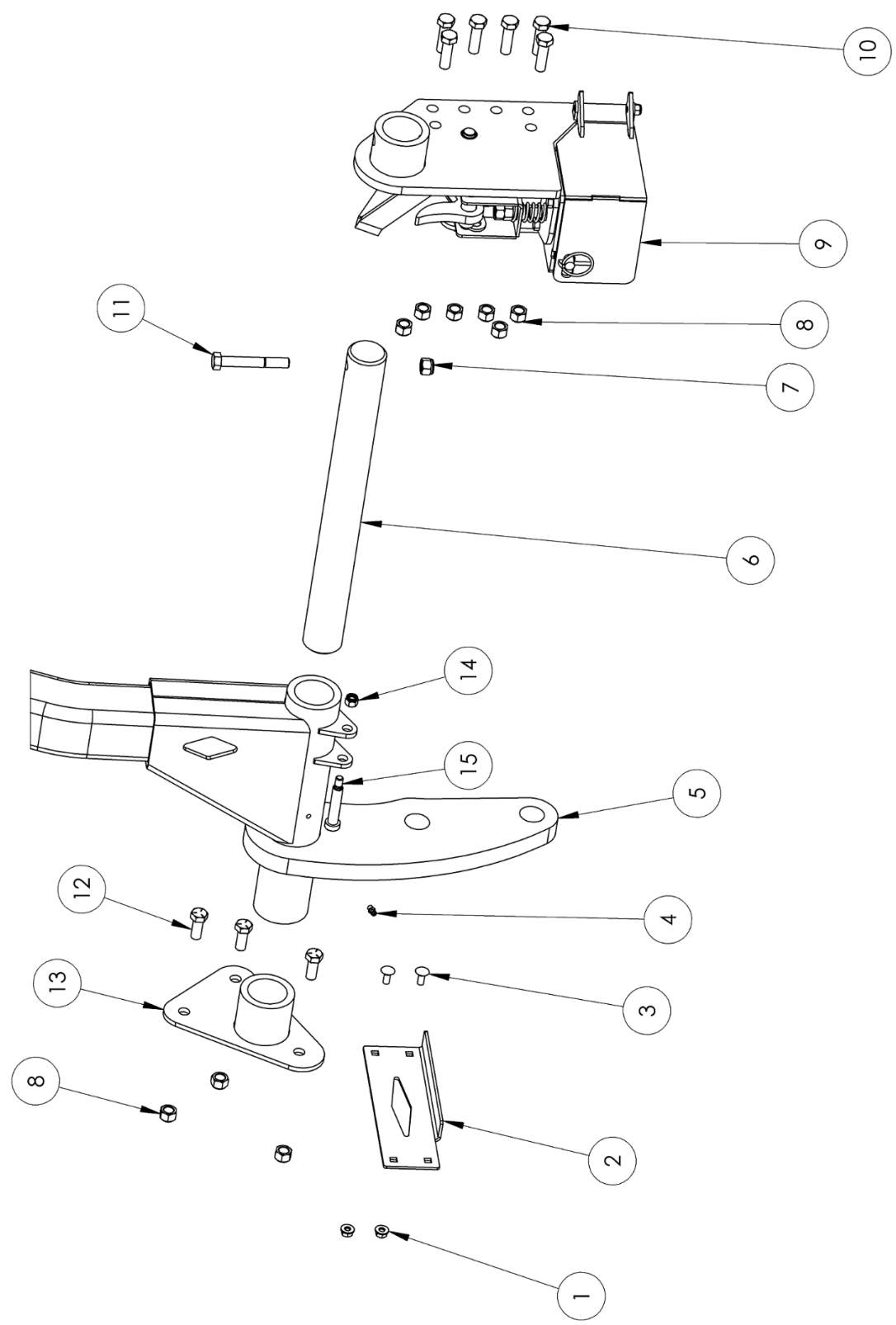

Three Bale Kit Left Arm (Series 1)

#	DESCRIPTION	PART #	QTY
1	Nut, 5/16" Serrated Flange	11814	2
2	SMV Adapter	31896	1
3	Bolt, 5/16" x 3/4" Carriage	11662	2
4	Grease Zerk	16364	1
5	3 Bale Kit Left Arm	31852	1
6	Arm Pin	31660	1
7	Nut, 1/2" Nylon Lock	16741	1
8	Nut, 1/2" Stover Lock Fine Thread	32153	9
9	Lockout Mechanism	SEE DETAIL	-
10	Bolt, 1/2" x 1-3/4" Fine Thread Gr. 8 NOTE: If your machine only has accommodation for 4 bolts instead of 6, the holes should be drilled out to 5/8" and a 5/8" x 1-3/4" UNF Gr.8 Bolt should be installed.	32151	6
11	Bolt, 1/2" x 3-1/2"	10353	1
12	Bolt, 1/2" x 1-1/4" Fine Thread Gr. 8	32152	3
13	Tub Mount	31873	2
14	Nut, 3/8" Nylon Lock	10806	1
15	Bolt, Shoulder 1/2" x 2-1/4" x 3/8"	31358	1

Three Bale Kit Lockout Mechanism (Series 1)

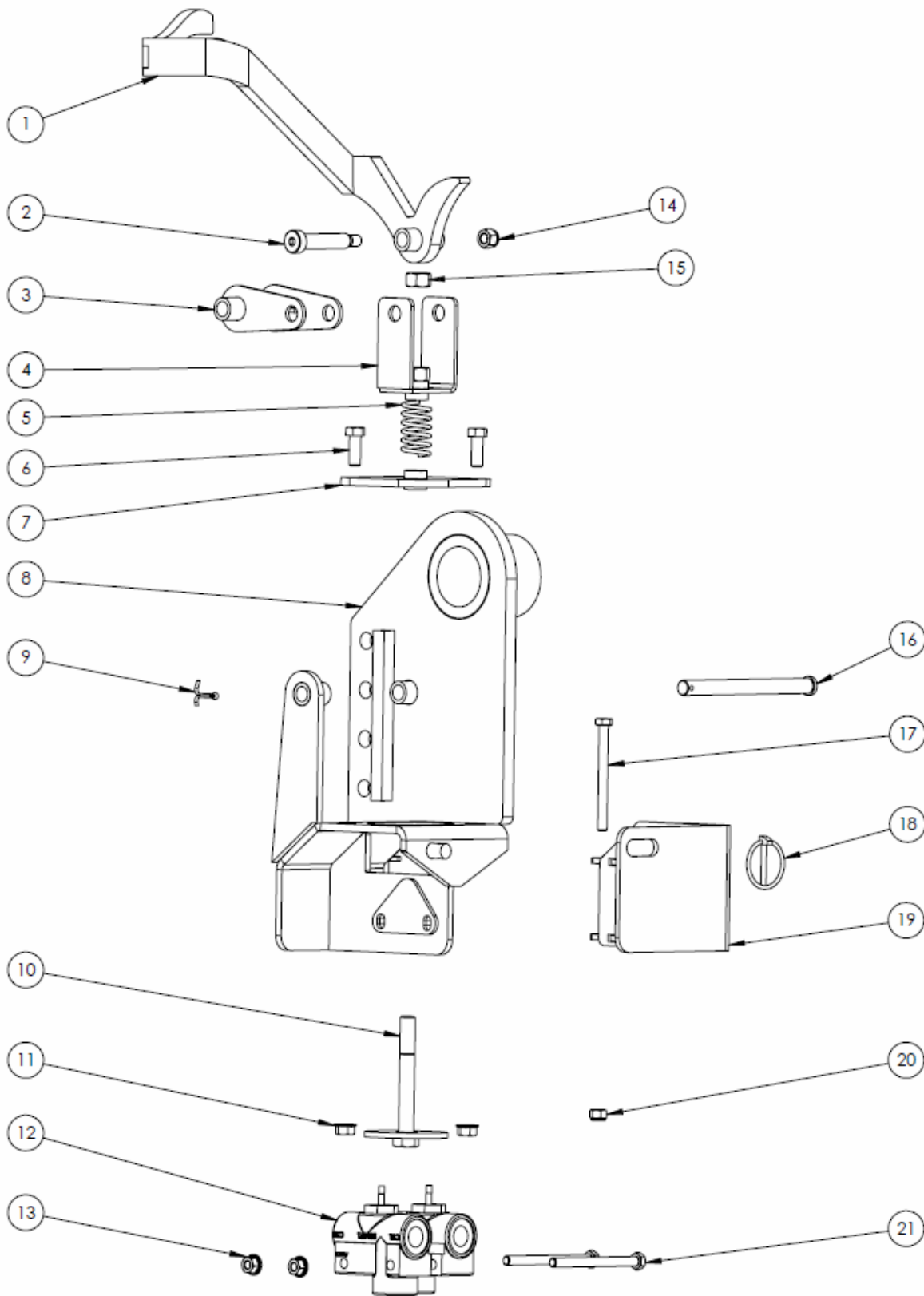

Three Bale Kit Lockout Mechanism (Series 1)

#	DESCRIPTION	PART #	QTY
1	3 Bale Kit Rocker	31934	1
2	Bolt, Shoulder 1/2" x 2-1/4" x 3/8"	31358	1
3	3 Bale Kit Spring Guide Rotator	31920	1
4	3 Bale Kit Upper Spring Guide	31915	1
5	Spring	19471	1
6	Bolt, 3/8" x 1"	13806	2
7	3 Bale Kit Lower Spring Guide	31911	1
8	3 Bale Kit Left Mount	31898	1
9	Cotter Pin	21169	1
10	3 Bale Kit Plunger	31925	1
11	Nut, 3/8" Serrated Flange	10271	2
12	3 Bale Kit Valve	30980	2
13	Nut, 5/16" Serrated Flange	11814	2
14	Nut, 3/8" Nylon Lock	10806	1
15	Nut, 1/2" Fine Thread	32167	1
16	Clevis Pin, 1/2" x 6"	31835	1
17	Bolt, 5/16" x 3-1/2"	30914	1
18	Lynch Pin	13233	1
19	Lockout Door	31928	1
20	Nut, 5/16" Nylon Lock	11815	1
21	Bolt, 5/16" x 4 1/2"	21836	2

Three Bale Kit Center (Series 1)

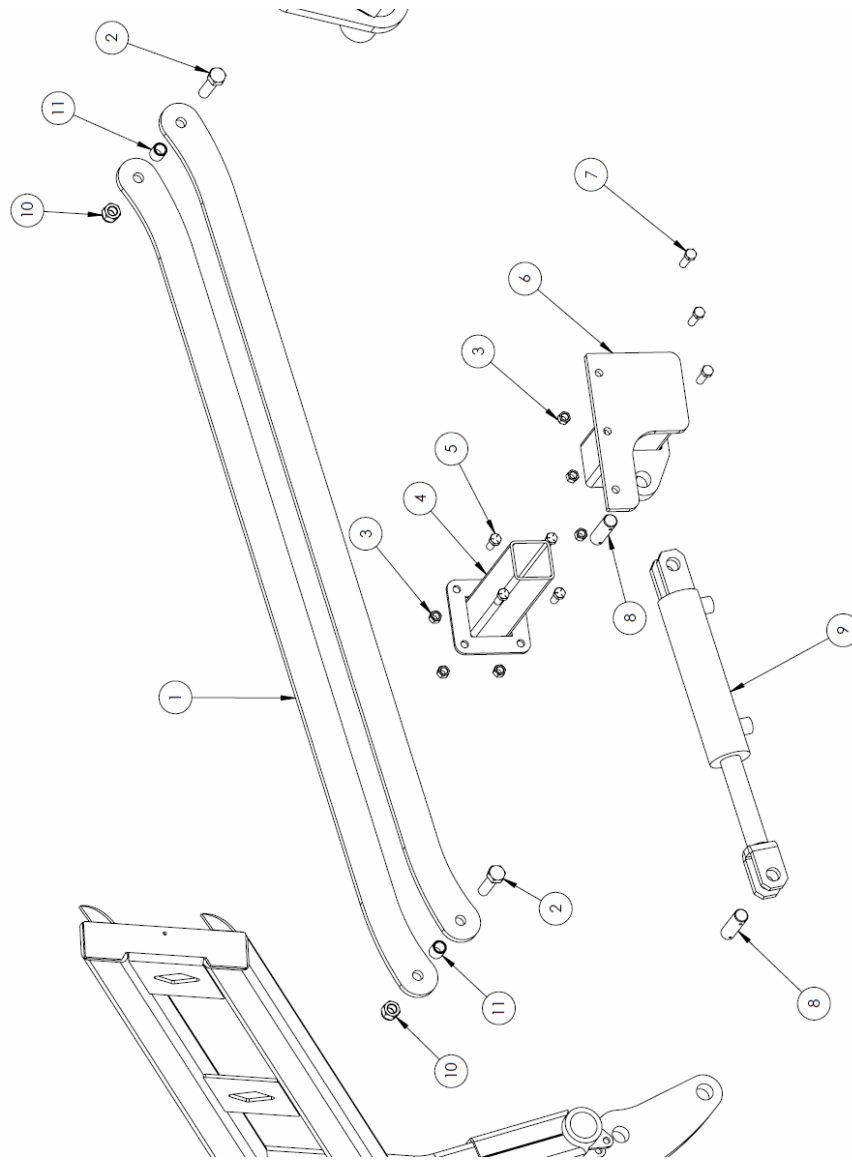

#	DESCRIPTION		PART #	QTY
1	3 Bale Kit Timing Bar	S/N BK7169 - BK7361	32236	2
	3 Bale Kit Timing Bar	S/N BK7168 & Below	32202	1
2	Bolt, 3/4 x 3"		27451	2
3	Nut, 1/2" Stover Lock Fine Thread		32153	7
4	3 Bale Kit Slider		31892	1
5	Bolt, 1/2" x 1-1/4" Fine Thread		32152	4
6	3 Bale Kit Cylinder Mount		31887	1
7	Bolt, 1/2" x 1-3/4" Fine Thread		32151	3
8	Cylinder Pin		22291	2
9	Hydraulic Cylinder		30126	1
10	Nut, 3/4" Nylon Lock		10007	2
11	Brass Spacer Bushing		29063	2

Three Bale Kit Right Arm (Series 1)

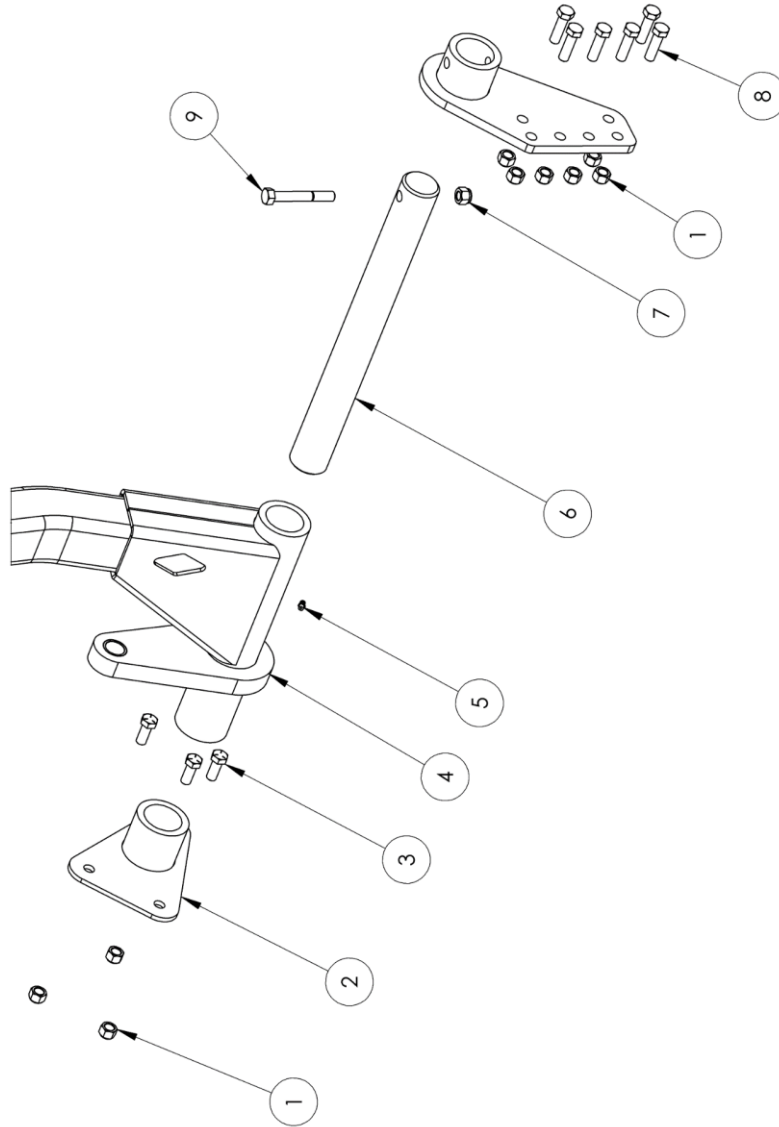

#	DESCRIPTION	PART #	QTY
1	Nut, 1/2" Stover Lock Fine Thread	32153	9
2	Tub Mount	31873	2
3	Bolt, 1/2" x 1-1/4" Fine Thread	32152	3
4	3 Bale Kit Right Arm	31854	1
5	Grease Zerk	16364	1
6	Arm Pin	31660	1
7	Nut, 1/2" Nylon Lock	16741	1
8	Bolt, 1/2" x 1-3/4" Fine Thread NOTE: If your machine only has accommodation for 4 bolts instead of 6, the holes should be drilled out to 5/8" and a 5/8" x 1-3/4" UNF Gr.8 Bolt should be installed.	32151	6
9	Bolt, 1/2" x 3-1/2"	10353	1

Three Bale Kit Left Arm (Series 2)

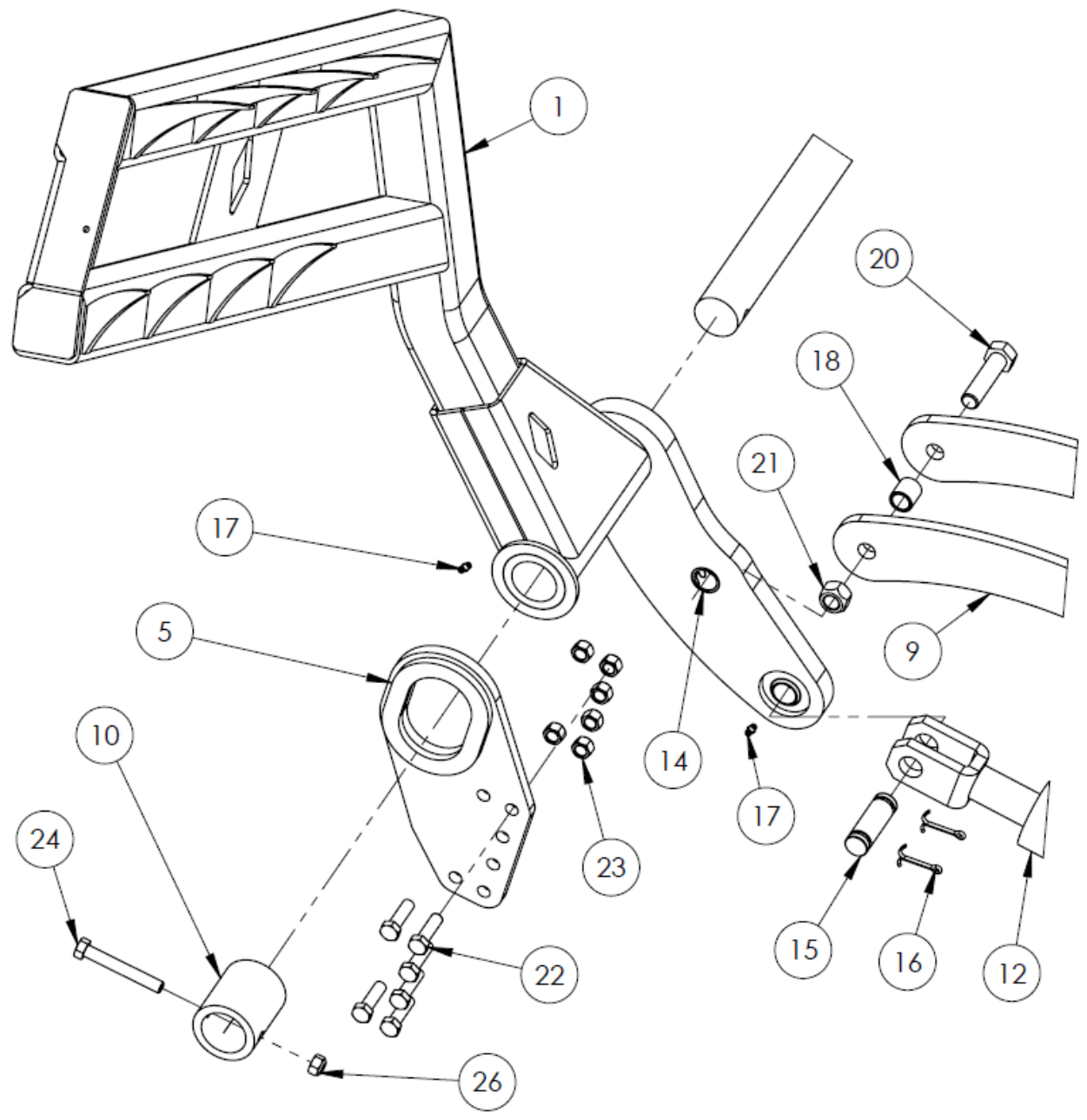

Three Bale Kit Center (Series 2)

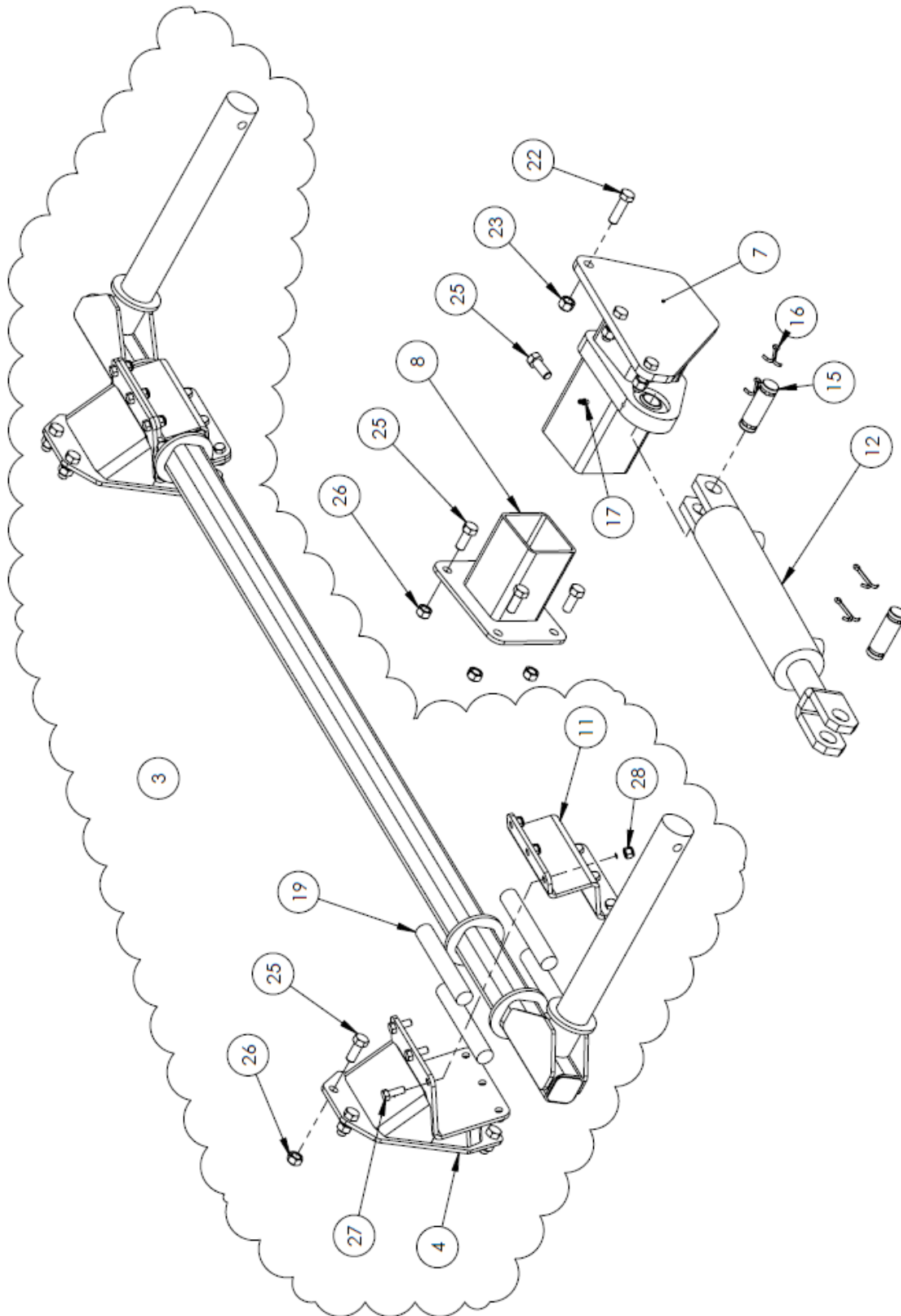

Three Bale Kit Right Arm (Series 2)

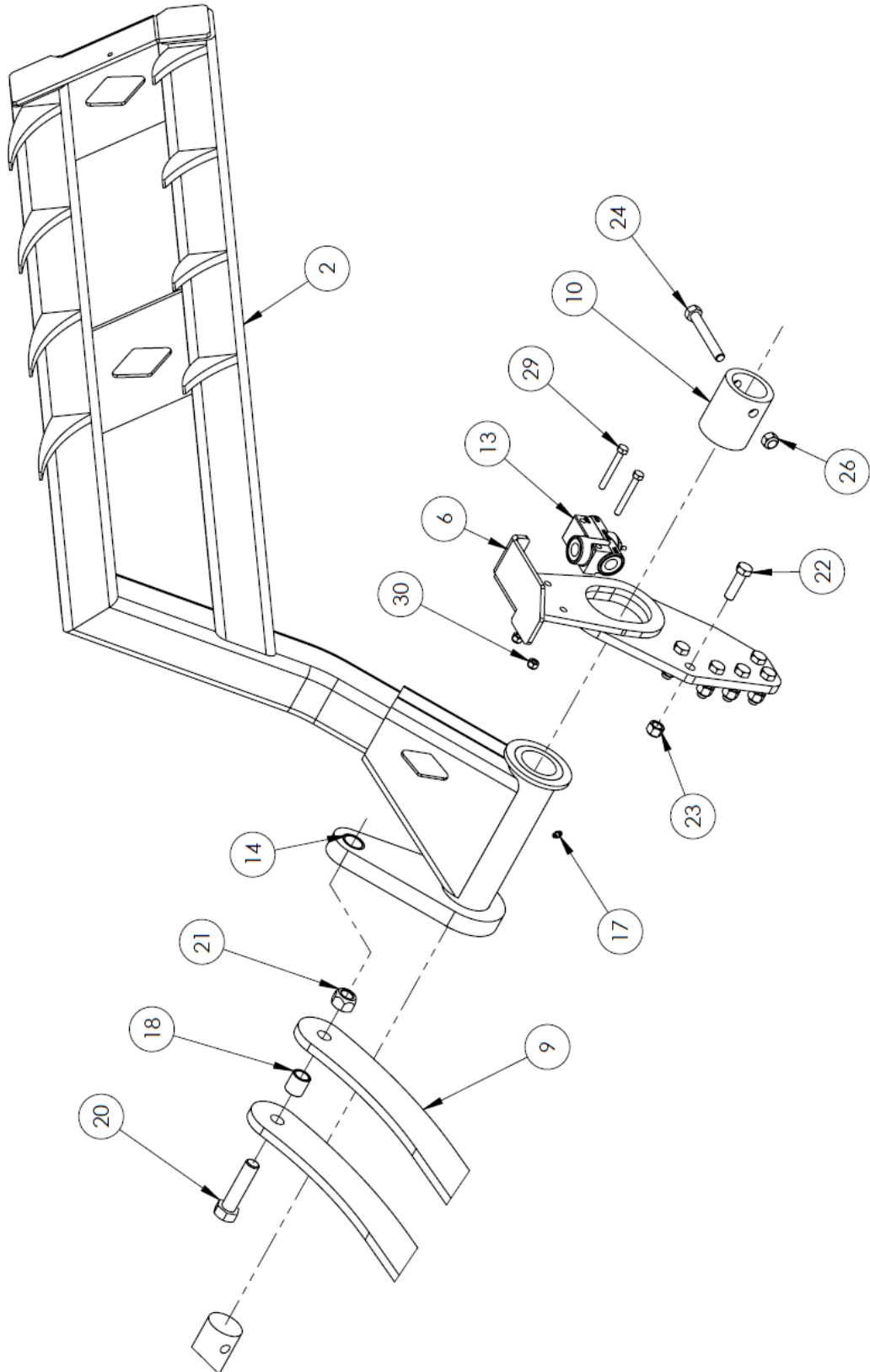

Three Bale Kit (Series 2)

#	DESCRIPTION	PART #	QTY
1	Left Arm	33328	1
2	Right Arm	33329	1
3	Torsion Bar Assembly * Individual parts not sold separately. Assembly not recommended *	33926	1
4	Torsion Bar Mount	NSS	2
5	Rear Support Left	33332	1
6	Rear Support Right	33333	1
7	Cylinder Base Mount	33334	1
8	Cylinder Mount Tub Adaptor	33387	1
9	Timing Bar	33335	2
10	Shaft Rear Bushing	33336	2
11	Torsion Clamp	NSS	2
12	Hydraulic Cylinder, 2-1/2" x 8" * Seal kit	Comes with pins 15 30126 17609	1
13	Depth Control Valve	30980	1
14	Press-in Bushing, 1"	23708	2
15	Cylinder Pin, 1 x 3-1/8"	10339	2
16	Cotter Pin, 3/16 x 1-1/2"	10072	4
17	Grease Zerk, 1/4"	16364	4
18	Bushing, 1" OD x 3/4" ID x 1-1/16"	29063	2
19	Rubber Torsion Bar	NSS	8
20	Bolt, 3/4 x 3"	27451	2
21	Nut, 3/4" Stover Lock	11823	2
22	Bolt, 1/2 x 1-3/4" Fine Thread	32151	15
23	Nut, 1/2" Stover Lock Fine Thread	32153	15
24	Bolt, 1/2 x 3-1/2"	10353	2
25	Bolt, 1/2 x 1-1/4"	10240	9
26	Nut, 1/2" Stover Lock	20154	10
27	Bolt, 3/8 x 1"	13806	12
28	Nut, 3/8" Nylon Lock	10806	12
29	Bolt, 5/16 x 2-1/2"	19115	2
30	Nut, 5/16" Nylon Lock	11815	2

Total Ration Grain Tank Option

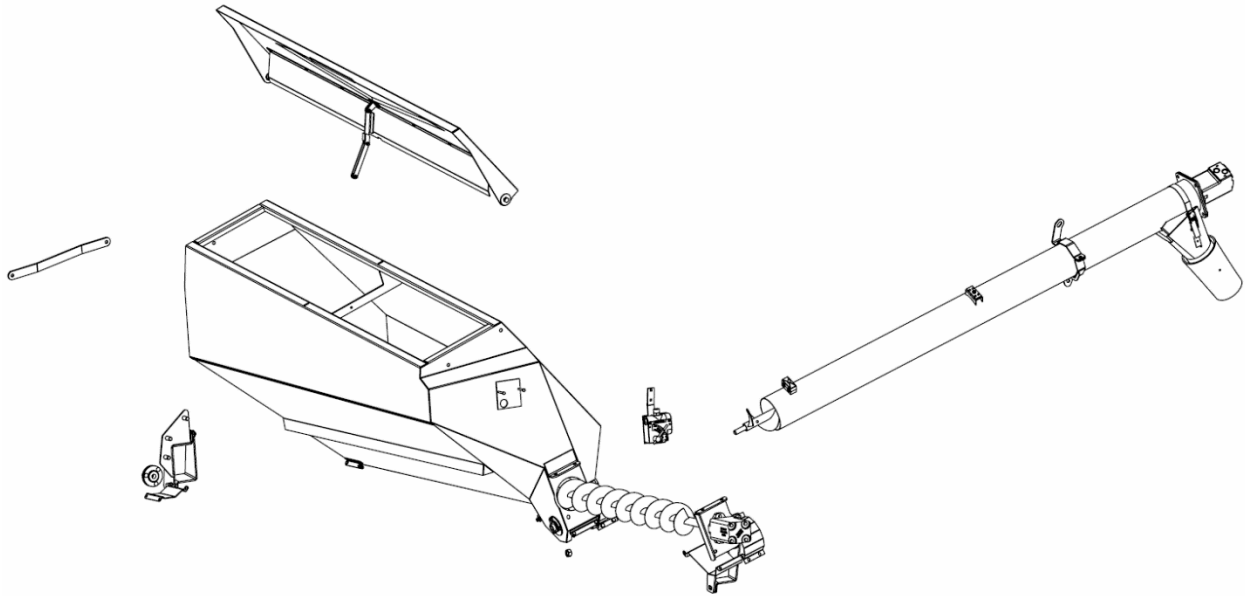

Item #	Description	
1	Tank Front	Page 80
2	Tank Rear	Page 82
3	Cross Auger	Page 84
4	Lid	Page 86

Total Ration Tank Front

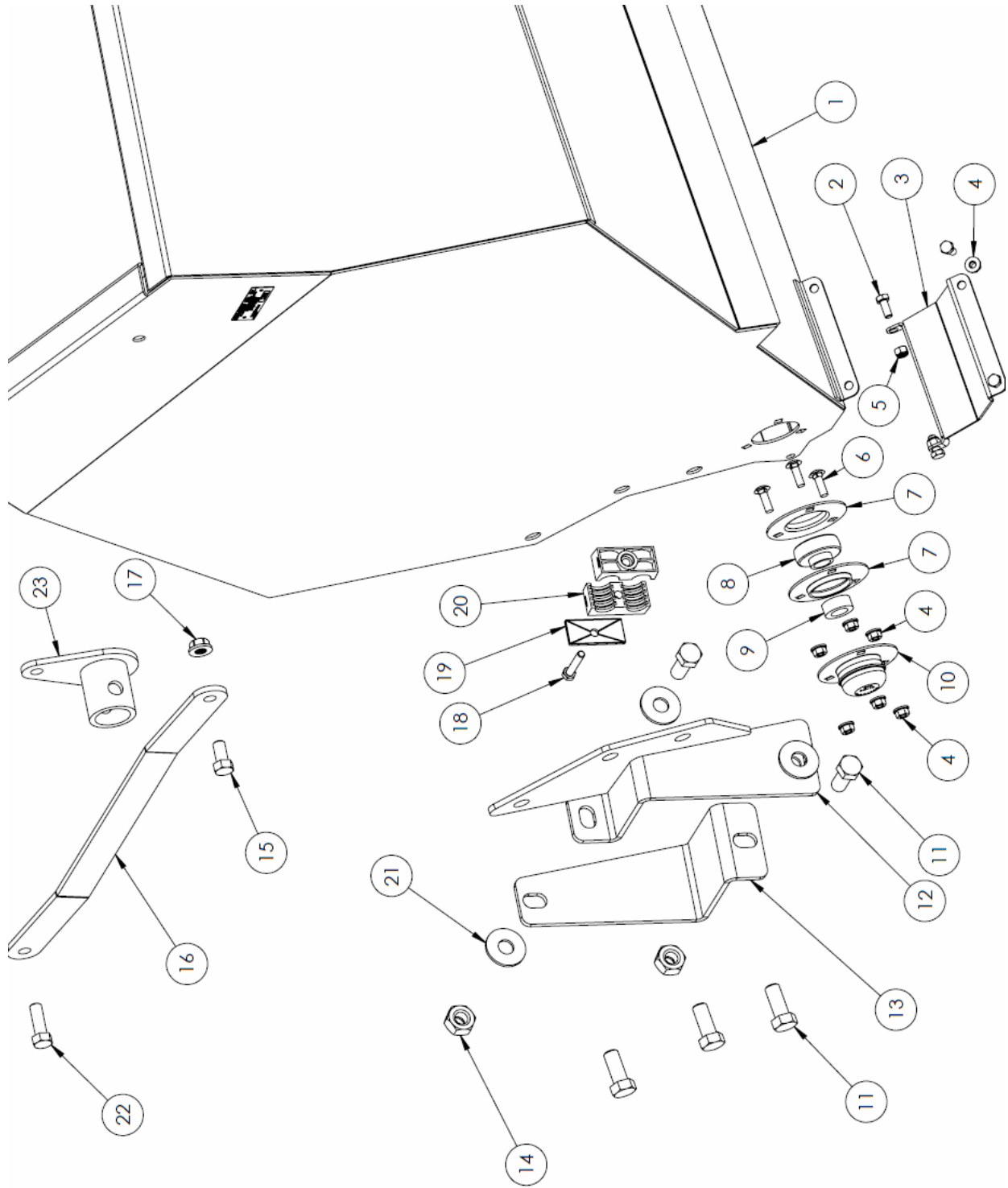

Total Ration Tank Front

#	DESCRIPTION	PART #	QTY
1	Total Ration Grain Tank	30199	1
2	Bolt, 5/16" x 3/4"	20903	4
3	Tank Cleanout Cover	30237	1
4	Nut, 5/16" Serrated Flange	11814	8
5	Nut, 5/16" Nylock	11815	2
6	Bolt, 5/16" x 1" Carriage	17884	3
7	Bearing, 3-Bolt Pressed Flange Housing	10368	2
8	Bearing, 3/4" Includes #9	10366	1
9	Bearing Lock Collar	10367	1
10	Bearing Cover	25117	1
11	Bolt, 5/8" x 1-1/2"	10173	5
12	5300 Front Mount Bracket	30242	1
	6200 Front Mount Bracket	30252	1
13	5300 Front Mount Strap	30239	1
	6200 Front Mount Strap	30250	1
14	Nut, 5/8" Stover Lock	20150	2
15	Bolt, 1/2" x 1"	10824	2
16	Grain Tank Top Strap	30402	2
17	Nut, 1/2" Serrated Flange	10273	2
18	Bolt, 5/16" x 1.75"	21726	1
19	Hydraulic Hose Clamp Cap, Large	21715	1
20	Hydraulic Hose Clamp, 1/2"	21561	2
21	Washer, 5/8" Flat	13975	4
22	Bolt, 1/2" x 1-1/2"	10174	2
23	Jack Stow Position Mount 6200 ONLY	30501	1

Total Ration Tank Rear

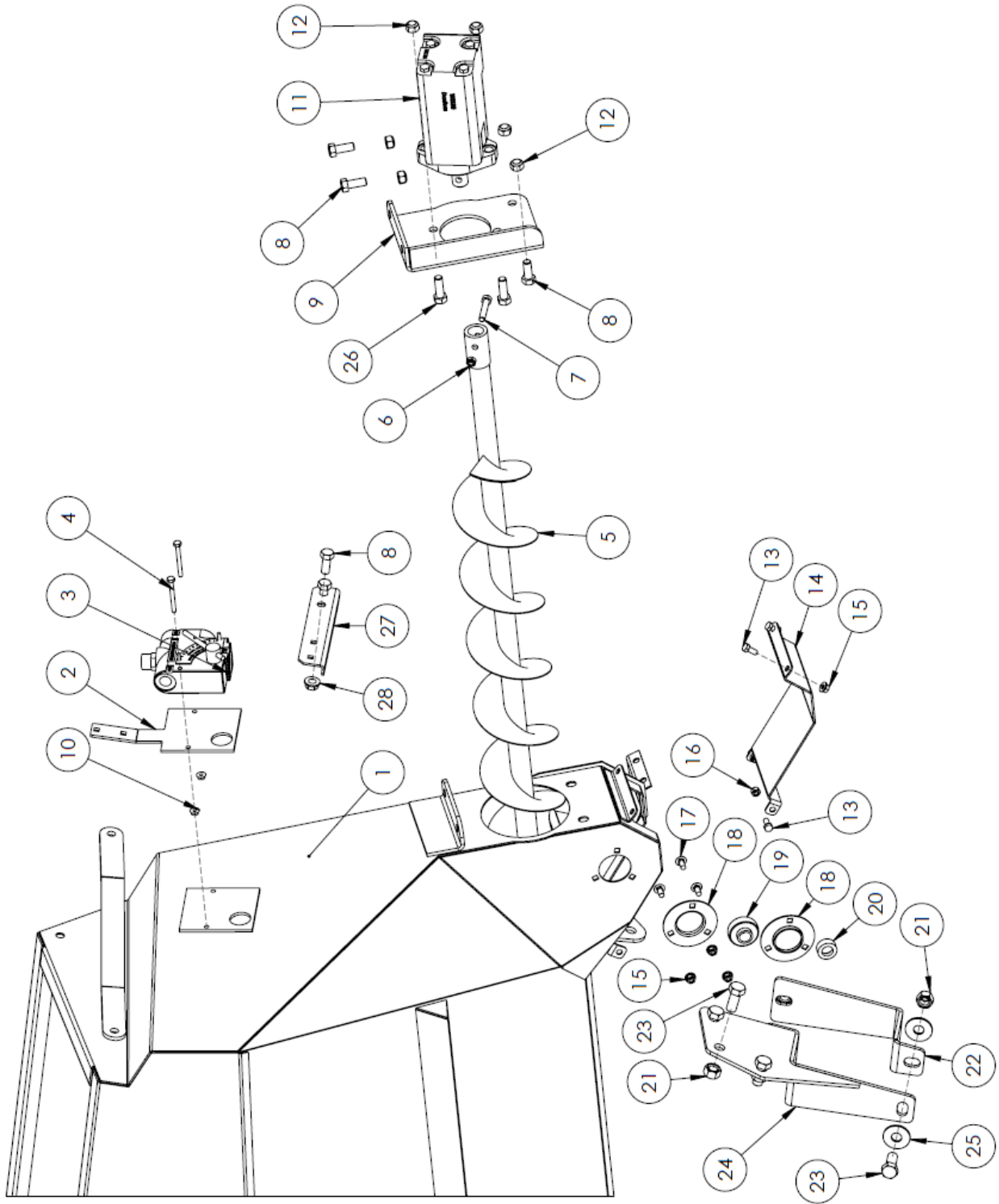

Total Ration Tank Rear

#	DESCRIPTION	PART #	QTY	
1	Total Ration Grain Tank	30199	1	
2	5300 SMV Sign Mount	S/N BK7253 & below	30389	1
3	Flow Control Valve	10455	1	
4	Bolt, 1/4 x 2-1/2"	S/N BK7254 & up	20954	2
	Bolt, 1/4 x 2-3/4"	S/N BK7253 & below	11811	
5	Tank Auger	30175	1	
6	Nut, 3/8" Stover Lock	17586	1	
7	Bolt, 3/8" x 2"	10279	1	
8	Bolt, 1/2 x 1-1/4"	10240	6	
9	Tank Motor Mount	30233	1	
10	Nut, 1/4" Nylon Lock	11664	2	
11	Tank Motor, WS230	31172	1	
12	Nut, 1/2" Stover Lock	14393	6	
13	Bolt, 5/16 x 3/4"	20903	4	
14	Cross Auger Cleanout Cover	30235	1	
15	Nut, 5/16" Serrated Flange	11814	5	
16	Nut, 5/16" Nylon Lock	11815	2	
17	Bolt, 5/16 x 3/4" Carriage	11662	3	
18	Bearing, 3-Bolt Pressed Flange Housing	10368	2	
19	Bearing, 3/4"	Includes #20	10366	1
20	Bearing Lock Collar	10367	1	
21	Nut, 5/8" Stover Lock	20150	5	
22	5300 Rear Mount Strap	30245	1	
	6200 Rear Mount Strap	30255	1	
23	Bolt, 5/8" x 1-1/2"	10173	5	
24	5300 Rear Mount Bracket	30247	1	
	6200 Rear Mount Bracket	30257	1	
25	Washer, 5/8" Flat	13975	4	
26	Bolt, 1/2 x 1-1/2"	10174	2	
27	SMV Sign Bracket	S/N BK7254 & up	33799	1
28	Nut, 1/2" Serrated Flange	10273	2	

Total Ration Cross Auger

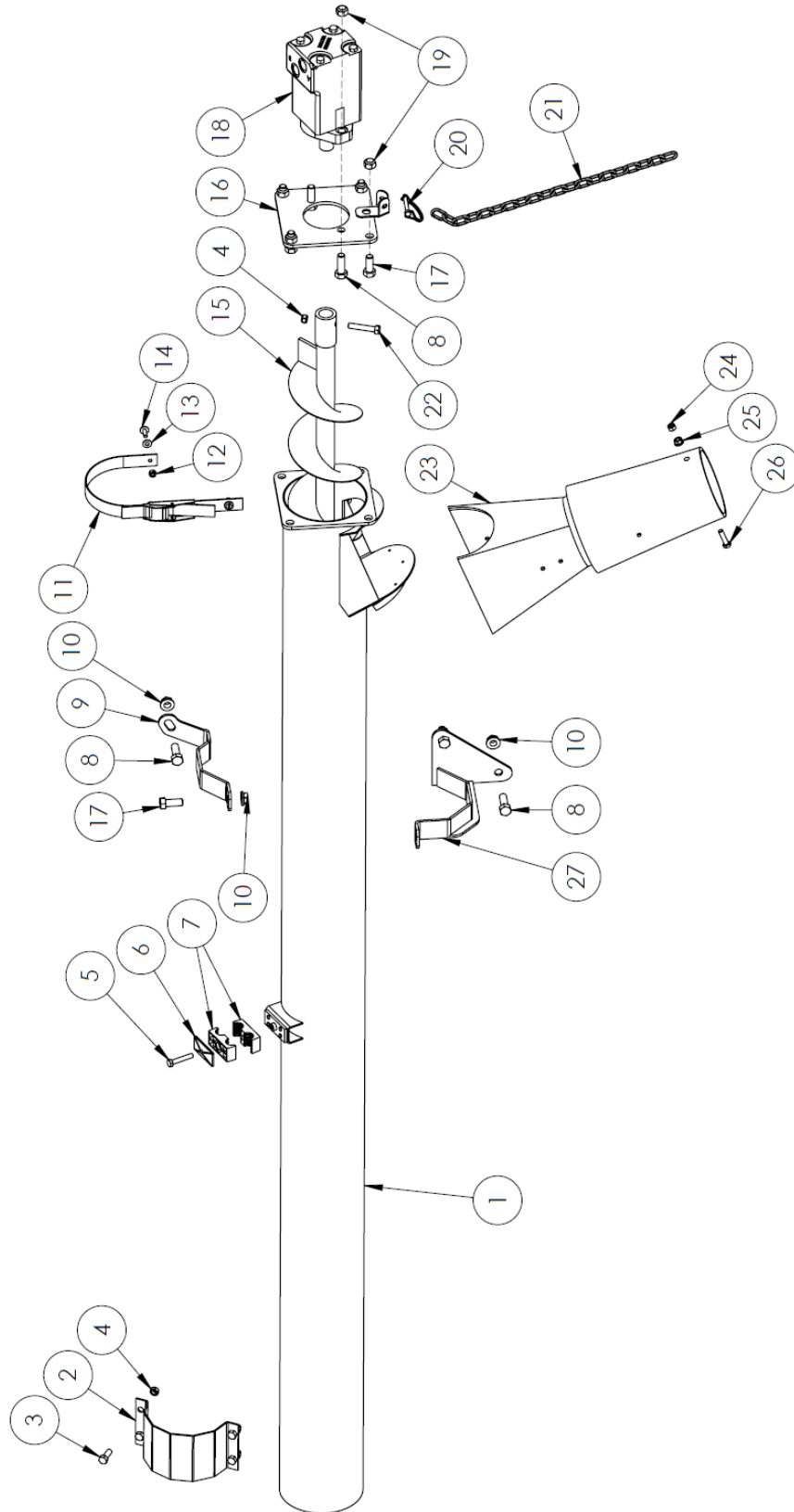

Total Ration Cross Auger

#	DESCRIPTION	PART #	QTY	
1	Cross Auger Pipe	30179	1	
2	Cross Auger Half Clamp	30401	1	
3	Bolt, 3/8" x 1"	13806	4	
4	Nut, 3/8" Stover Lock	17586	5	
5	Bolt, 5/16" x 1-3/4"	21726	1	
6	Hydraulic Hose Clamp Cap, Large	21715	1	
7	Hydraulic Hose Clamp, 1/2"	21561	2	
8	Bolt, 1/2" x 1-1/2"	10174	5	
9	Cross Auger Top Clamp	30187	1	
10	Nut, 1/2" Serrated Flange	10278	8	
11	Spout Strap	Includes both parts	25122	1
12	Nut, 1/4" Nylon Lock	11664	2	
13	Washer, 1/4" Flat	14448	2	
14	Bolt, 1/4" x 3/4" Truss Head	17638	2	
15	Cross Auger	30169	1	
16	Cross Auger Motor Mount	30194	1	
17	Bolt, 1/2" x 1-1/4"	10240	4	
18	Cross Auger Motor, WS080	30132	1	
19	Nut, 1/2" Stover Lock	14393	6	
20	Lock Pin, 1/4" x 1.25"	13951	1	
21	Chain, 3/16" x 20 links	25121	1	
22	Bolt, 3/8" x 2"	10279	1	
23	Auger Spout	10543	1	
24	Nut, 5/16" Nylon lock	11815	1	
25	Nut, 5/16" Serrated Flange	11814	1	
26	Bolt, 5/16" x 1-1/4"	24418	1	
27	Cross Auger Bottom Clamp	30189	1	

Total Ration Tank Lid

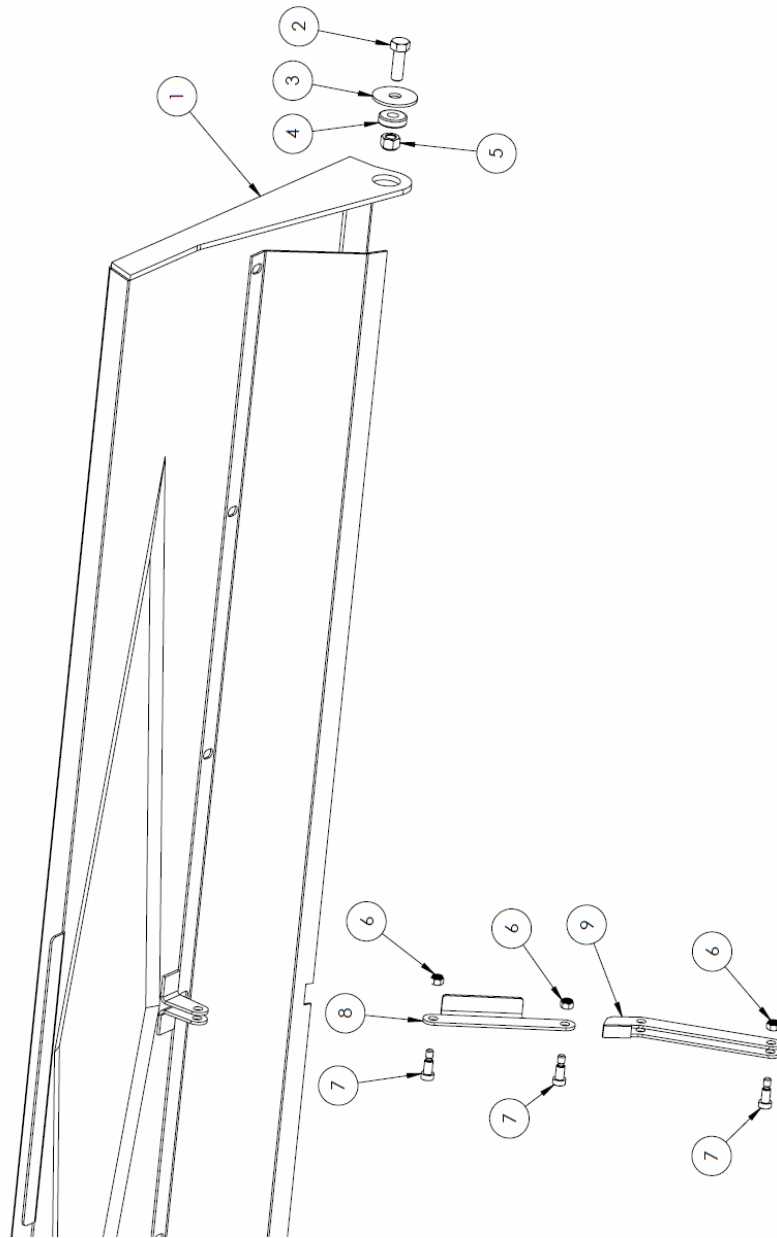

#	DESCRIPTION	PART #	QTY
1	Grain Tank Lid	30165	1
2	Bolt, 1/2" x 1-1/4"	10240	2
3	Washer, 1/2" Fender	10238	2
4	Bushing, 1/2" ID x 1.250" OD	10239	2
5	Nut, 1/2" Stover Lock	14393	2
6	Nut, 5/16" Nylon Lock	11815	3
7	Bolt, 3/8" x 5/8" Shoulder	30466	3
8	Lid Upper Support	30163	1
9	Lid Lower Support	30166	1

Fine Chop Option

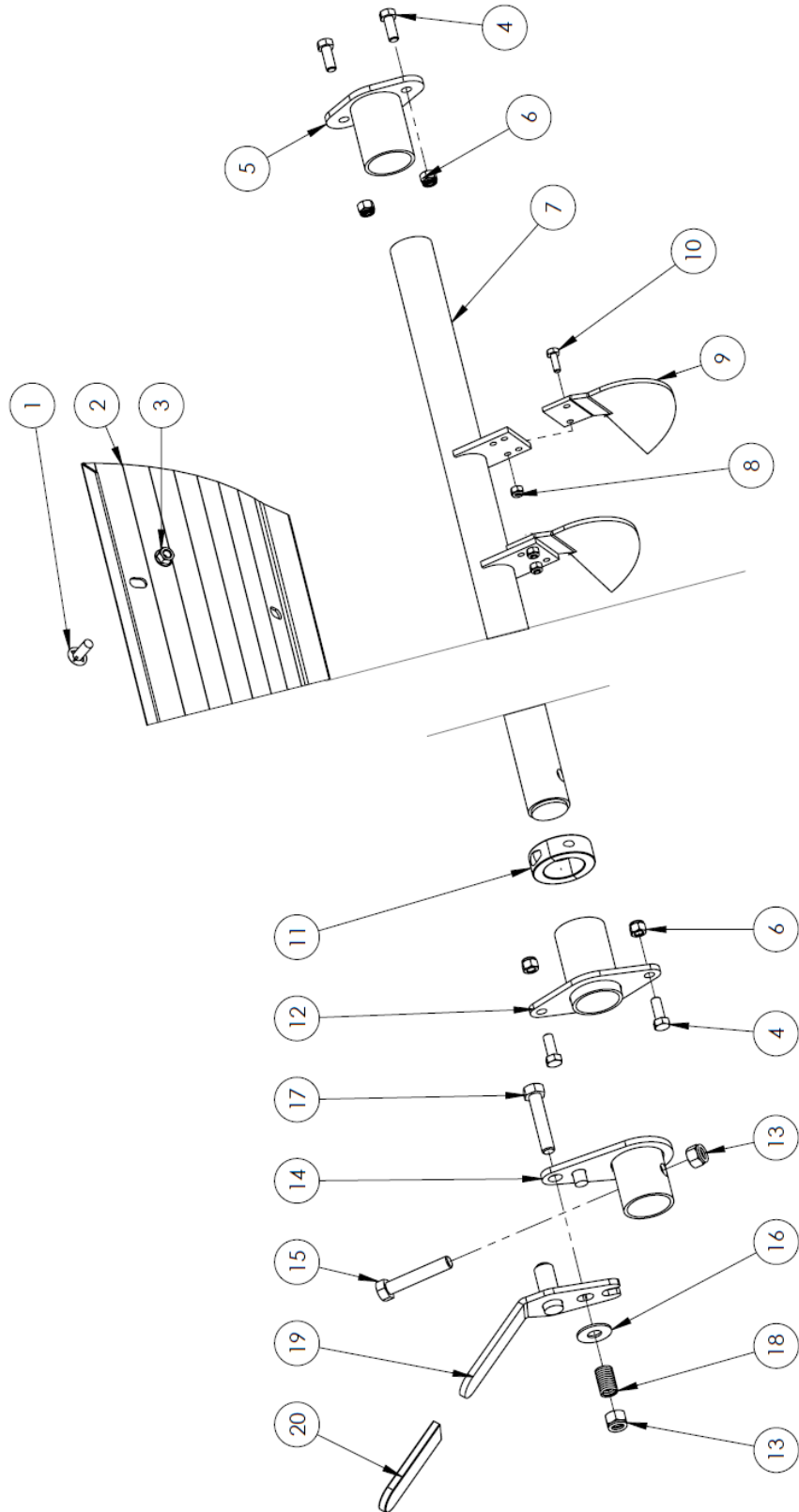

Fine Chop Option

#	DESCRIPTION	PART #	QTY
	Fine Chop Cover * IF NO FINE CHOP INSTALLED *		
1	Fin Bolt, 3/8" x 3/4"	10807	8
2	Fine Chop Cover Plate	22438	1
3	Nut, 3/8" Serrated Flange	10271	8

	Fine Chop Kit * Optional *	32117	1
4	Bolt, 3/8" x 1"	13806	4
5	Fine Chop Mount	22444	1
6	Nut, 3/8" Nylon Lock	10806	4
7	Fine Chop Bar	32118	1
8	Nut, 1/4" Nylon Lock	11664	26
9	Fine Chop Blade	10404	13
10	Bolt, 1/4" x 3/4"	11809	26
11	Split Collar	12792	1
12	Fine Chop Front Mount	32122	1
13	Nut, 1/2" Nylon Lock	10241	2
14	Fine Chop Pivot	32127	1
15	Bolt, 1/2" x 2-3/4"	12378	1
16	Flat Washer, 1/2"	11668	1
17	Bolt, 1/2" x 2-1/2"	10804	1
18	Compression Spring	21713	1
19	Fine Chop Handle	32132	1
20	Rubber Cover	10297	1

Twine Cutter Option

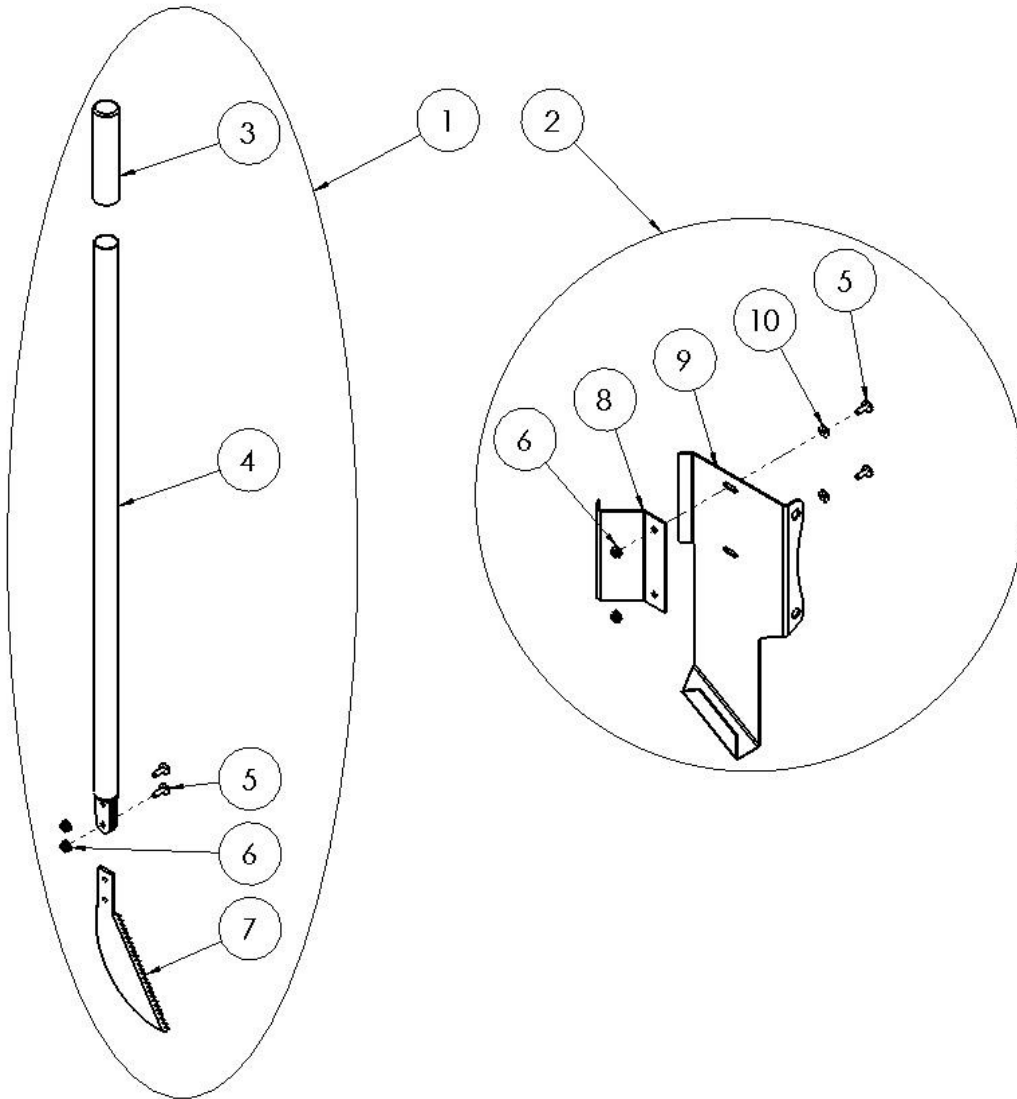

#	DESCRIPTION	PART #	QTY
	Twine Cutter Kit	17686	1
1	Twine Cutter Handle Kit	-	1
2	Twine Cutter Holder Kit	21549	1
3	Rubber Handle Cap	17587	1
4	Twine Cutter Handle	20862	1
5	Bolt, 1/4" x 3/4" Truss Head	17638	4
6	Nut, 1/4" Serrated Flange	11812	4
7	Twine Cutter Blade	17438	1
8	Twine Cutter Holder Inside Bracket	17690	1
9	Twine Cutter Holder Outside Bracket	17691	1
10	Flat Washer, 1/4"	11666	2

Back-up Camera Option

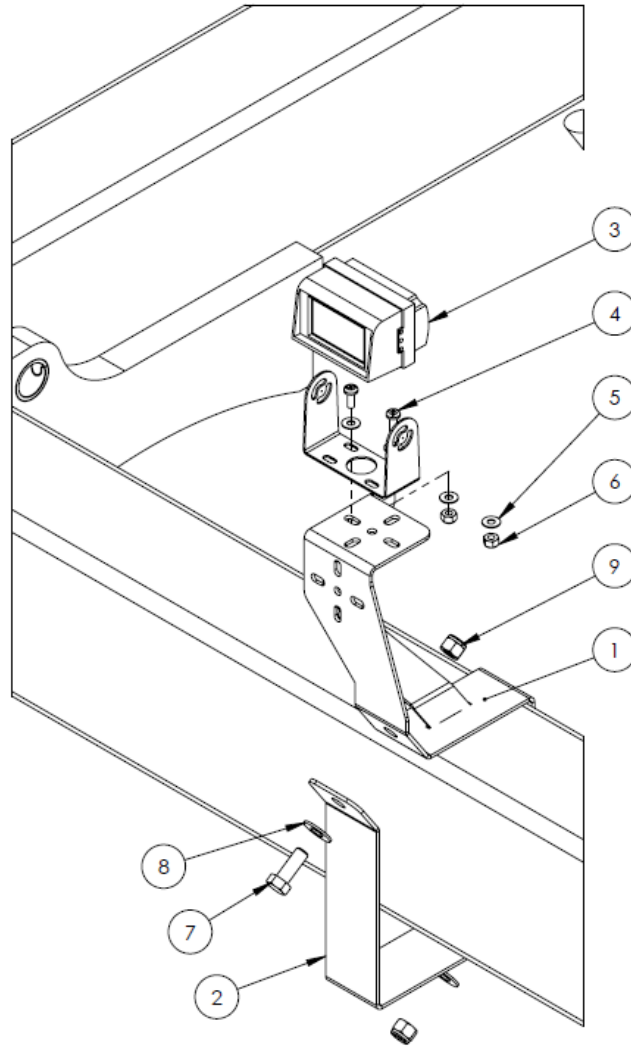

#	DESCRIPTION	PART #	QTY
	Complete Back-up Camera Kit - Standard	32619	-
	Complete Back-up Camera Kit - Pro	32628	-
1	Camera Mounting Bracket	32618	1
2	Camera Mounting Strap	32617	1
3	* Back-up Camera – Standard	32640	1
	* Back-up Camera – Pro	32639	
4	Bolt, #10 x 1/2"	17035	2
5	Washer, #10 Flat	25600	4
6	Nut, #10 Nylon Lock	31110	2
7	Bolt, 3/8 x 1"	13806	2
8	Washer, 3/8" Flat	11667	4
9	Nut, 3/8" Nylon Lock	10806	2
10	Extension Cable, 15'	32645	1
11	Grommet, 5/16" ID x 1/4"	13179	2

***NOTE: Camera package comes with camera bracket, monitor, and harnesses**

Diverter Control Box

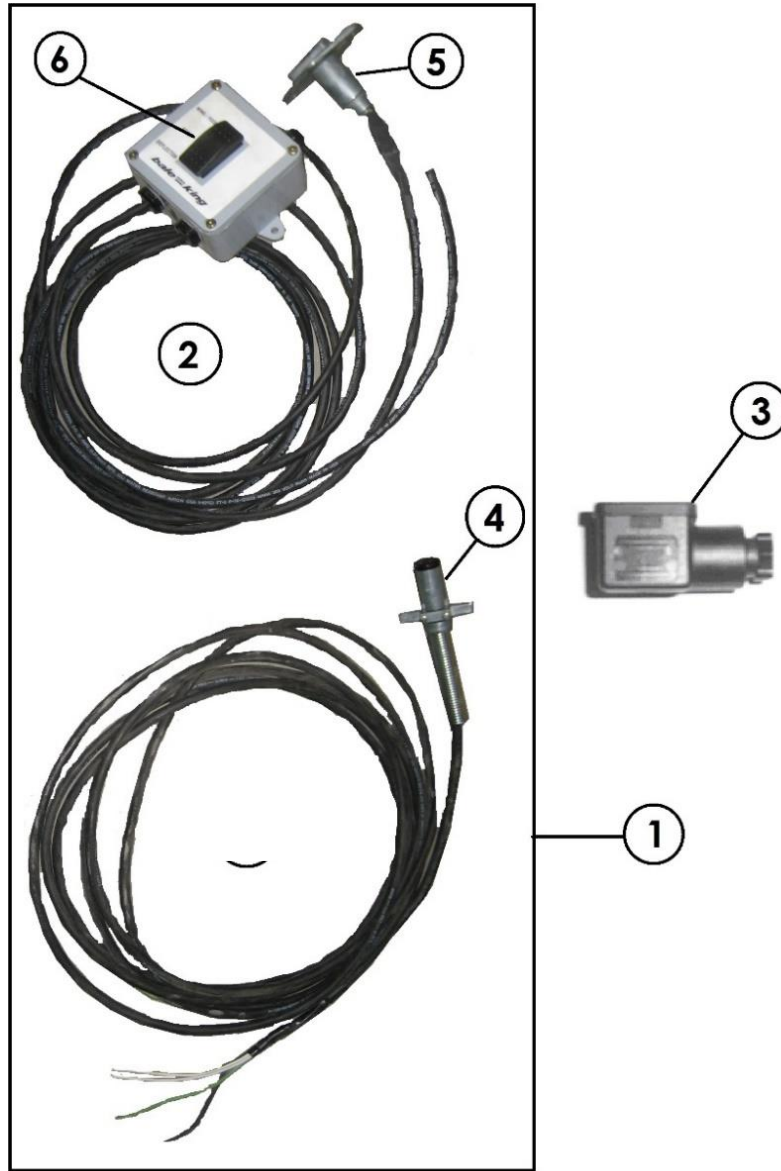

#	DESCRIPTION	PART #	QTY
1	Complete Control Box with Harness (Standard)	24466	1
	Complete Control Box with Harness (4 Function) #	33134	
2	Complete Control Box with Cab to Hitch Harness (5300 Series)	-	1
3	Square Plug for Diverter Valve	13657	*
4	4-pin Trailer Plug	24691	1
5	4-pin Tractor Plug	24690	1
6	3-way Switch	13561	1

* **NOTE:** 1 plug is needed for each diverter valve.

NOTE: Only used on 5300XTR with 2-remote kit (3 diverter valves)

Diverter Machine Side Harness

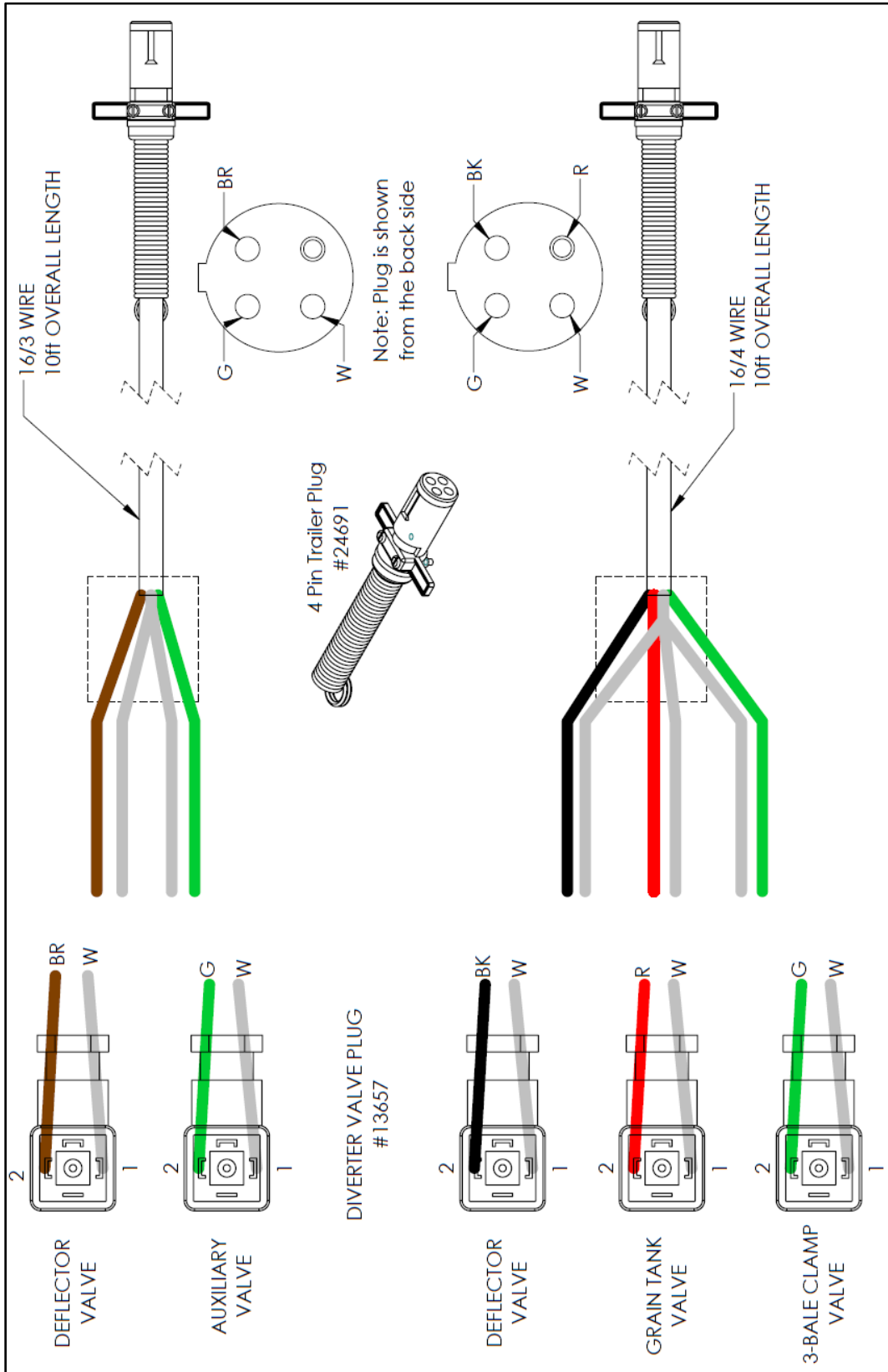

Diverter Control Box #24466

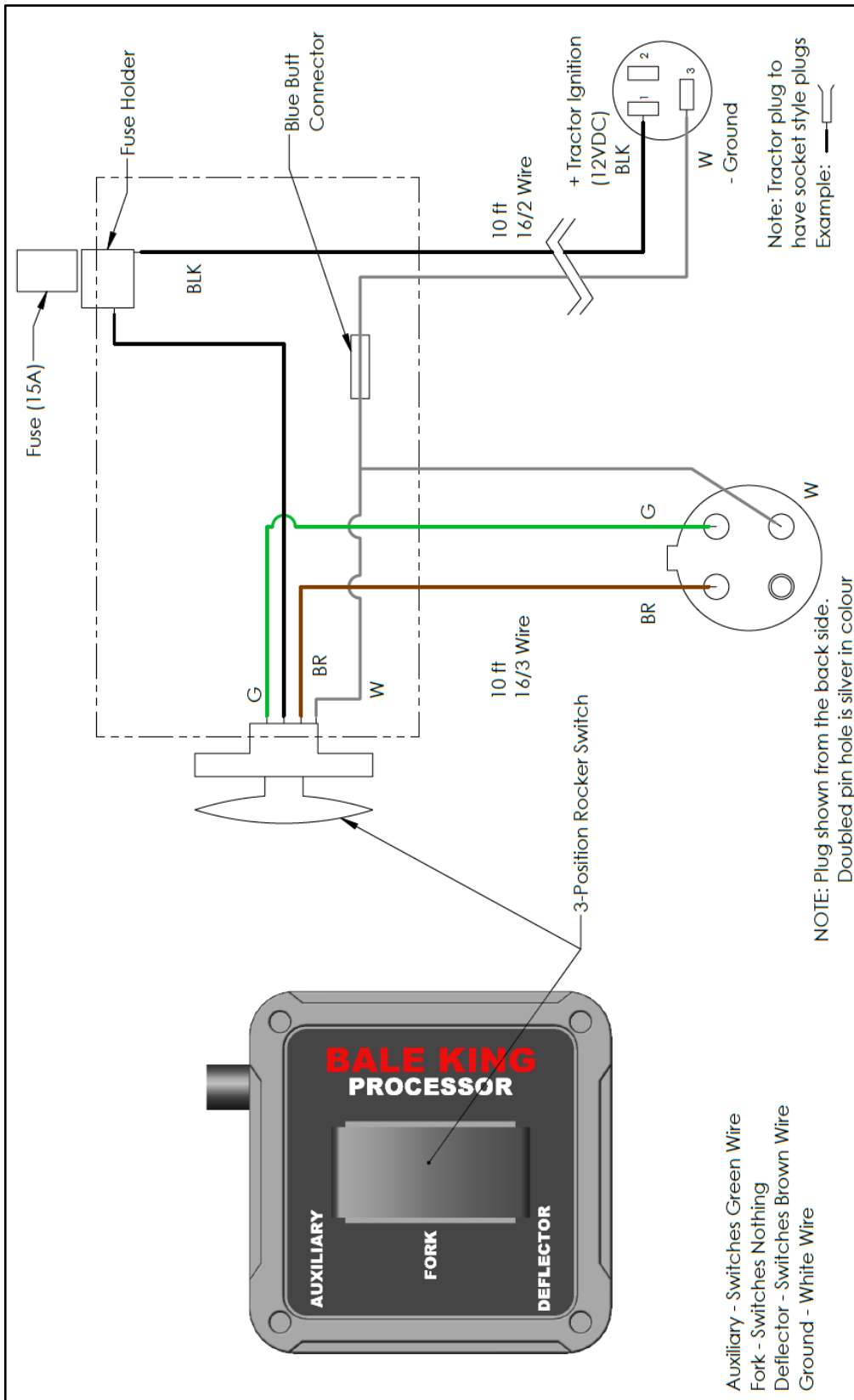



Diverter Control Box #33134 (4 Function with Additional Push Button Switch)

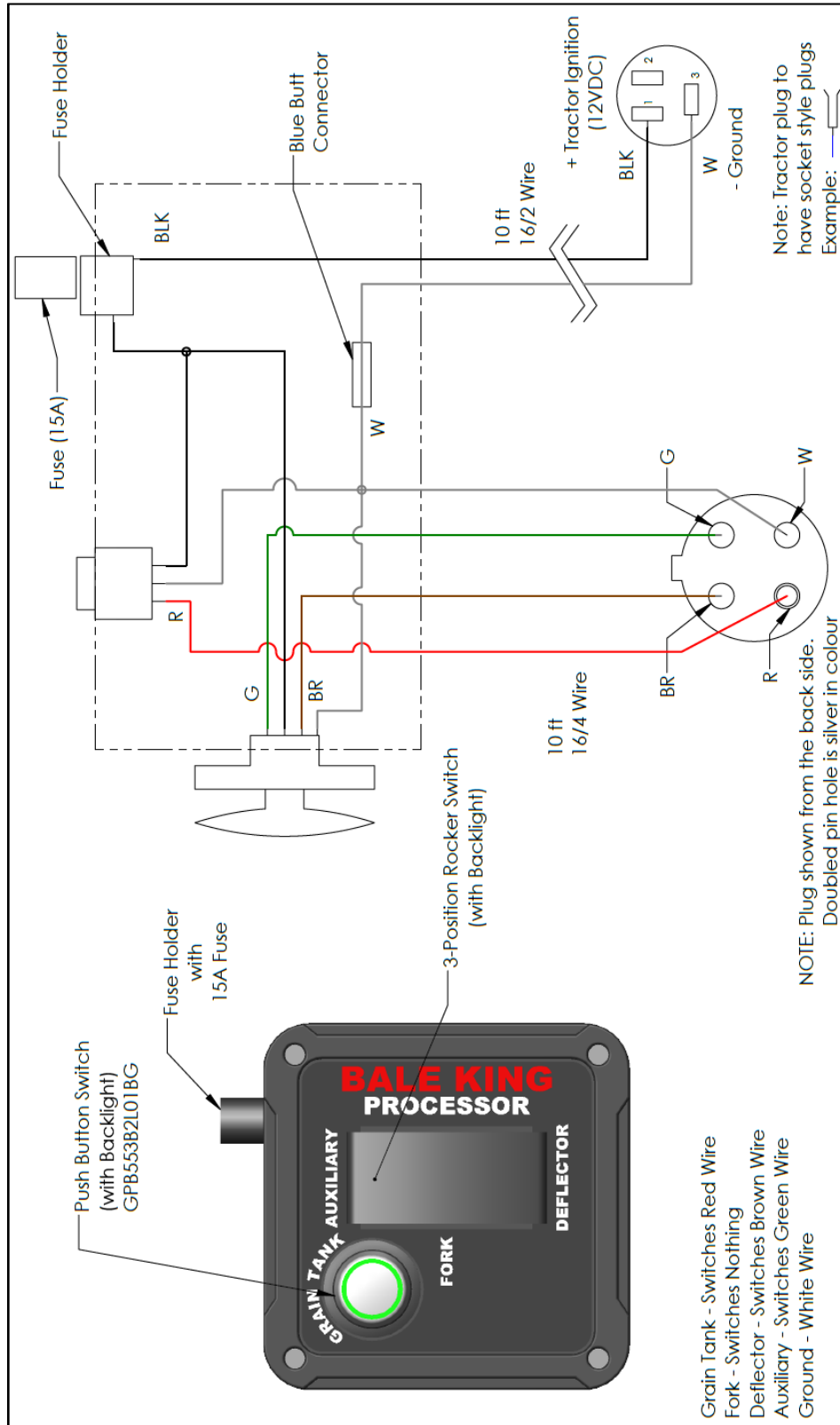

HYDRAULIC SCHEMATICS

HYDRAULIC COMPONENTS	97
HYDRAULIC FITTINGS	98
HYDRAULIC HOSES	99
FRONT PANEL – AGITATORS	100
FRONT PANEL – 3-REMOTE	101
FRONT PANEL – 2-REMOTE	102
FRONT PANEL – 1 OPTION, 4-REMOTE	103
FRONT PANEL – 1 OPTION, 3-REMOTE	104
FRONT PANEL – 1 OPTION, 2-REMOTE	105
FRONT PANEL – 2 OPTION, 4-REMOTE	106
FRONT PANEL – 2 OPTION, 3-REMOTE	107
FRONT PANEL – 2 OPTION, 2-REMOTE	108
REAR FORK – S/N BK7565 & ABOVE.....	109
REAR FORK AND THREE BALE KIT – S/N BK7565 & ABOVE	110
REAR FORK – S/N BK7362 - BK7564.....	111
REAR FORK AND THREE BALE KIT – S/N BK7362 - BK7564	112
REAR FORK – S/N BK7361 & BELOW	113
REAR FORK AND THREE BALE KIT – S/N BK7361 & BELOW	114
TR GRAIN TANK KIT	115

Machine	Marker	Function	Page #
5300 3 Remote	Long Red	Turn Agitators Clockwise	100
	Long Blue	Lift Rear Fork	109
	Long Yellow	Lift Discharge Deflector	101
5300 2 Remote	Long Red	Turn Agitators Clockwise	100
	Long Blue	Lift Rear Fork / Lift Discharge Deflector	109 102
5300TR 4 Remote	Long Red	Turn Agitators Clockwise	100
	Long Blue	Lift Rear Fork	109
	Long Yellow	Lift Discharge Deflector	103
	Long Green	Discharge Grain	115
5300TR 3 Remote	Long Red	Turn Agitators Clockwise	100
	Long Blue	Lift Rear Fork / Lift Discharge Deflector	109 104
	Long Green	Discharge Grain	115
5300TR 2 Remote	Long Red	Turn Agitators Clockwise	100
	Long Blue	Lift Rear Fork /	109
		Lift Discharge Deflector / Discharge Grain	105 115
5300X 4 Remote	Long Red	Turn Agitators Clockwise	100
	Long Blue	Lift Rear Fork	110112
	Long Yellow	Lift Discharge Deflector	103
	Long Green	Close Clamp	112
5300X 3 Remote	Long Red	Turn Agitators Clockwise	100
	Long Blue	Lift Rear Fork / Lift Discharge Deflector	110 104
	Long Green	Close Clamp	110
5300X 2 Remote	Long Red	Turn Agitators Clockwise	100
	Long Blue	Lift Rear Fork /	110
		Lift Discharge Deflector / Close Clamp	105 110
5300XTR 4 Remote	Long Red	Turn Agitators Clockwise	100
	Long Blue	Lift Rear Fork /	110
		Lift Discharge Deflector	106
	Long Yellow	Close Clamp	110
5300XTR 3 Remote	Long Green	Discharge Grain	115
	Long Red	Turn Agitators Clockwise	100
		Lift Rear Fork /	110
		Lift Discharge Deflector / Close Clamp	107 110
Long Green	Discharge Grain	115	
5300XTR 2 Remote	Long Red	Turn Agitators Clockwise	100
		Lift Rear Fork /	110
		Lift Discharge Deflector / Close Clamp / Discharge Grain	108 110 115
	Long Blue		

HYDRAULIC COMPONENTS

#	DESCRIPTION		PART #
AA	Hydraulic Cylinder – 2.5 x 8 x 1.5” *Seal Kit	3 Bale Kit Arms	30126 17609
BB	WS230 Hydraulic Motor – WS230	Tank Auger	31172
CC	Hydraulic Cylinder - 3 x 18 x 1.5” * Seal Kit * Stopper Kit	Rear Forks	21717 20807 21860
DD	Hydraulic Cylinder - 1.5 x 6 x 1” * Seal Kit	Deflector	21711 23738
EE	Depth Control Valve		30980
FF	Flow Control Valve	TR Only	10455
GG	Diverter Valve * Nut & O-Ring * Magnet * Stack Kit *Triple Stack Kit		11743 17977 11789 12895 12897
HH	Pilot-operated Check Valve 5/16” x 2” Mounting Hardware x 2 5/16” Serrated Flange Nuts x 2		19114
II	Check Valve, 8MJ-8FB		12171
JJ	Pioneer Tip, 8FB		17379
KK	Hose Marker, Long Red		20791
LL	Hose Marker, Short Red		20790
MM	Hose Marker, Long Blue		34985
NN	Hose Marker, Short Blue		18497
OO	Hose Marker, Long Yellow		34984
PP	Hose Marker, Short Yellow		16520
QQ	Hose Marker, Long Green		20789
RR	Hose Marker, Short Green		16522
SS	Hydraulic Motor * Seal Kit	Agitator	25872 25891
TT	Flow Divider Valve		25778
UU	Hydraulic Motor – WS080	Cross Auger	30132

NOTE: Quantities vary depending on machine set-up. Order as required.

HYDRAULIC FITTINGS

#	DESCRIPTION	PART #
A	Adaptor, 10MB-8MJ	10161
B	Adaptor, 10MB-8MJ90	12169
C	Adaptor, 10MB-8MJ45	23844
D	Adaptor, 10MB-6MJ	11739
E	Adaptor, 10MB-6MJ45	22722
F	Adaptor, 8MBR-8MJT	22159
G	Adaptor, 8MB-6MJ	11740
H	Adaptor, 8MB-6MJ90	10200
I	Adaptor, 8MB-4MJ *not required if hose has 8MB end*	22160
J	Adaptor, 8MJ90BH	10531
K	Adaptor, 8MJ45BH	22189
L	Adaptor, 8FJXR-8MJT	11768
M	Adaptor, 6MBR-6MJT	23726
N	Adaptor, 6MB-6MJ	10162
O	Adaptor, 6MB-6MJ90	10201
P	Adaptor, 6MJBH90	10187
Q	Adaptor, 6MJ-6FJX90	12162
R	Adaptor, 6MB-6MJ Orifice (1/32")	17436
S	Adaptor, 8MJBH	28774
T	Adaptor, 12MB-8MJ	25937
U	Adaptor, 6MJBH	11767
V	Adaptor, 8MB Plug	31013
W	Adaptor, 12MB-8MJ90	22174
X	Adaptor, 6MJBH45	21319
Y	Adaptor, 8MB-6MB90	33739
Z	Adaptor, 6FJXR-6MJT	15760

NOTE: Quantities vary depending on machine set-up. Order as required.

HYDRAULIC HOSES

#	DIA.	LENGTH	ENDS	#	DIA.	LENGTH	ENDS
1	1/2"	160" OAL	8FJX - 8MB	26	1/4"	20.25" OAL	6FJX - 6FJX90
2	1/2"	33" OAL	8FJX - 8MB	27	1/4"	16.25" OAL	6FJX - 6FJX90L
3	1/2"	125" OAL	8FJX90 - 8MB	28	1/4"	13.5" OAL	6FJX - 6FJX
4	1/2"	48" OAL	8FJX - 8FJX	29	1/4"	12.25" OAL	6FJX - 6FJX90L
5	1/2"	98" OAL	8FJX - 8MB	30	3/8"	8.5" OAL	6FJX - 6FJX
6	1/2"	24" OAL	8FJX - 8FJX90	31	1/2"	81" OAL	8FJX - 8FJX
7	1/2"	44.5" OAL	8FJX - 8FJX90	32	1/2"	122" OAL	8MB - 8FJX
8	1/2"	102" OAL	8FJX90 - 8FJX	33	3/8"	78" OAL	6FJX - 8FJX
9	1/2"	122" OAL	8FJX - 8FJX90	34	3/8"	56" OAL	6FJX - 8FJX90
10	1/2"	42" OAL	8FJX - 8FJX45	35	3/8"	81" OAL	6FJX - 8FJX
11	1/2"	40" OAL	8FJX - 8FJX45	36	3/8"	24.5" OAL	6FJX - 6FJX
12	3/8"	122" OAL	6FJX - 8MB	37	3/8"	24" OAL	6FJX - 6FJX45
13	3/8"	79.5" OAL	6FJX - 6FJX	38	3/8"	28" OAL	6FJX - 6FJX45
14	3/8"	78" OAL	6FJX - 8FJX90	39	3/8"	87" OAL	6FJX - 6FJX45
15	3/8"	57.5" OAL	6FJX - 8FJX	40	3/8"	29" OAL	8FJX - 6FJX45
16	3/8"	35.5" OAL	6FJX - 8FJX	41	3/8"	26" OAL	8FJX - 6FJX90
17	3/8"	33.5" OAL	6FJX - 8FJX	42	3/8"	38" OAL	8FJX - 6FJX90
18	3/8"	17.25" OAL	6FJX - 6FJX90	43	3/8"	30" OAL	6FJX - 6FJX90
19	3/8"	13.5" OAL	6FJX - 6FJX	44	3/8"	28" OAL	6FJX - 6FJX
20	3/8"	11.25" OAL	6FJX - 6FJX90	45	3/8"	24" OAL	6FJX - 6FJX
21	3/8"	9.25" OAL	6FJX - 6FJX	46	3/8"	47" OAL	6FJX - 6FJX90
22	3/8"	8.75" OAL	6FJX - 6FJX	47	3/8"	58" OAL	6FJX - 6FJX
23a	1/4"	131" OAL	4FJX - 6FJX90L	48	3/8"	29.5" OAL	8FJX - 8FJX
23b		139" OAL	(8MB-6FJX90L * if available *)	49	3/8"	29" OAL	6FJX - 6FJX90
				50	3/8"	25" OAL	6FJX - 6FJX90
24	1/4"	35" OAL	6FJX - 6FJX90	51	3/8"	16" OAL	6FJX - 8FJX
25	1/4"	26" OAL	6FJX - 6FJX90	52	3/8"	14.25" OAL	6FJX - 8FJX

NOTE: Quantities vary based on machine set-up. Hoses are not available for sale.

Use the information above to have replacement hoses made up locally.

All hoses should be double braid, with crimps rated for at least 3500 psi.

FRONT PANEL – AGITATORS

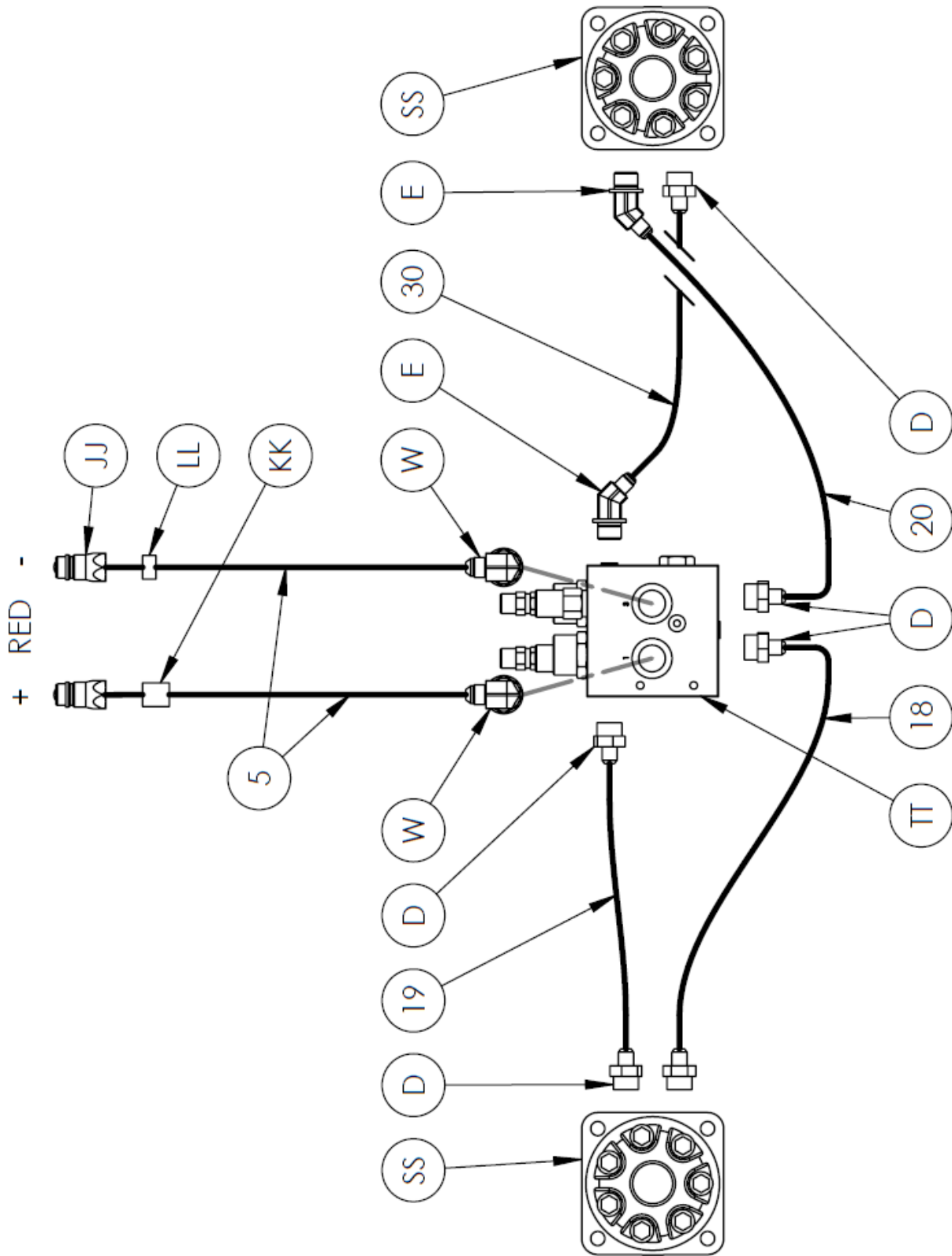

FRONT PANEL – 3-REMOTE

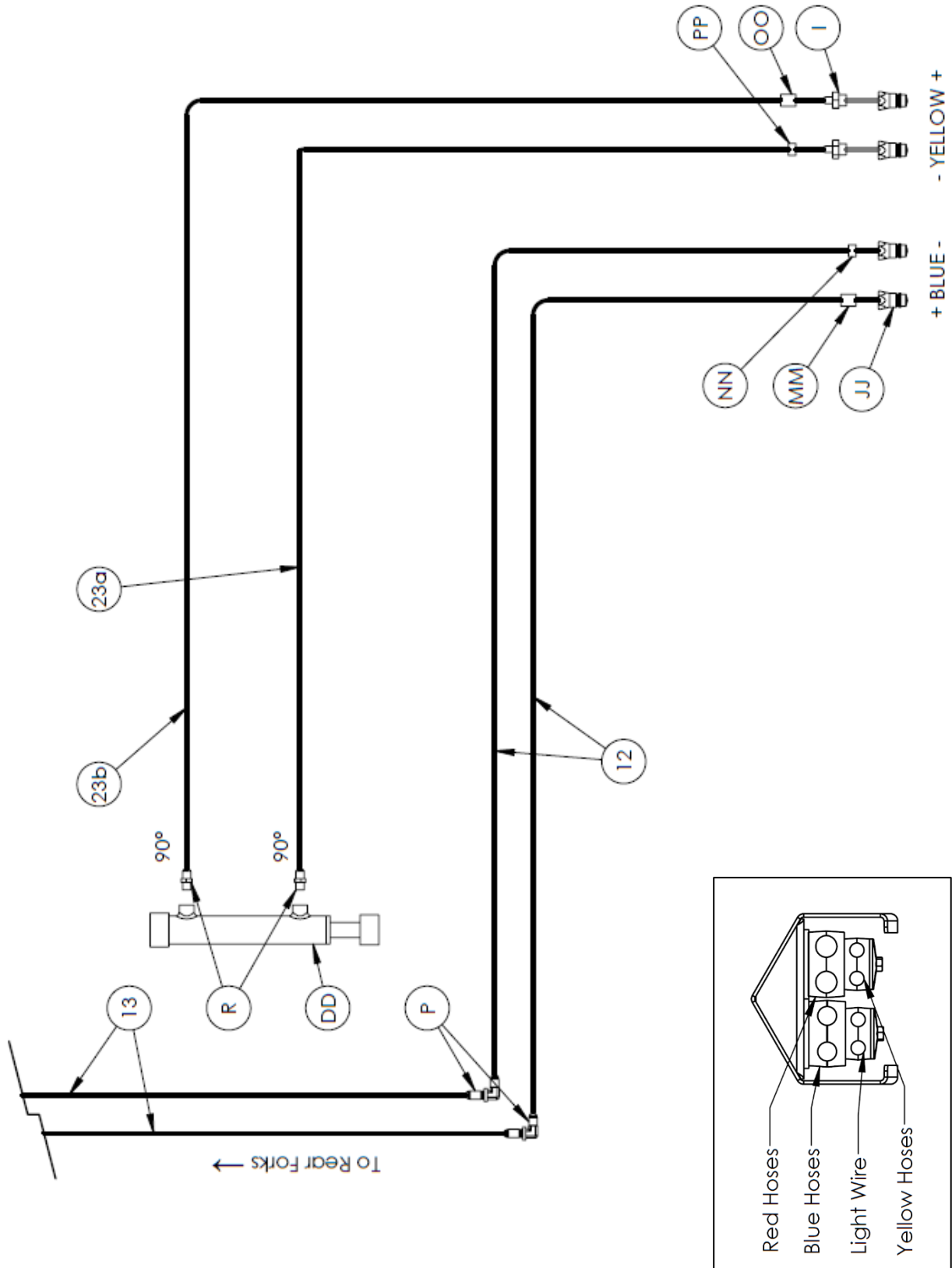

FRONT PANEL – 2-REMOTE

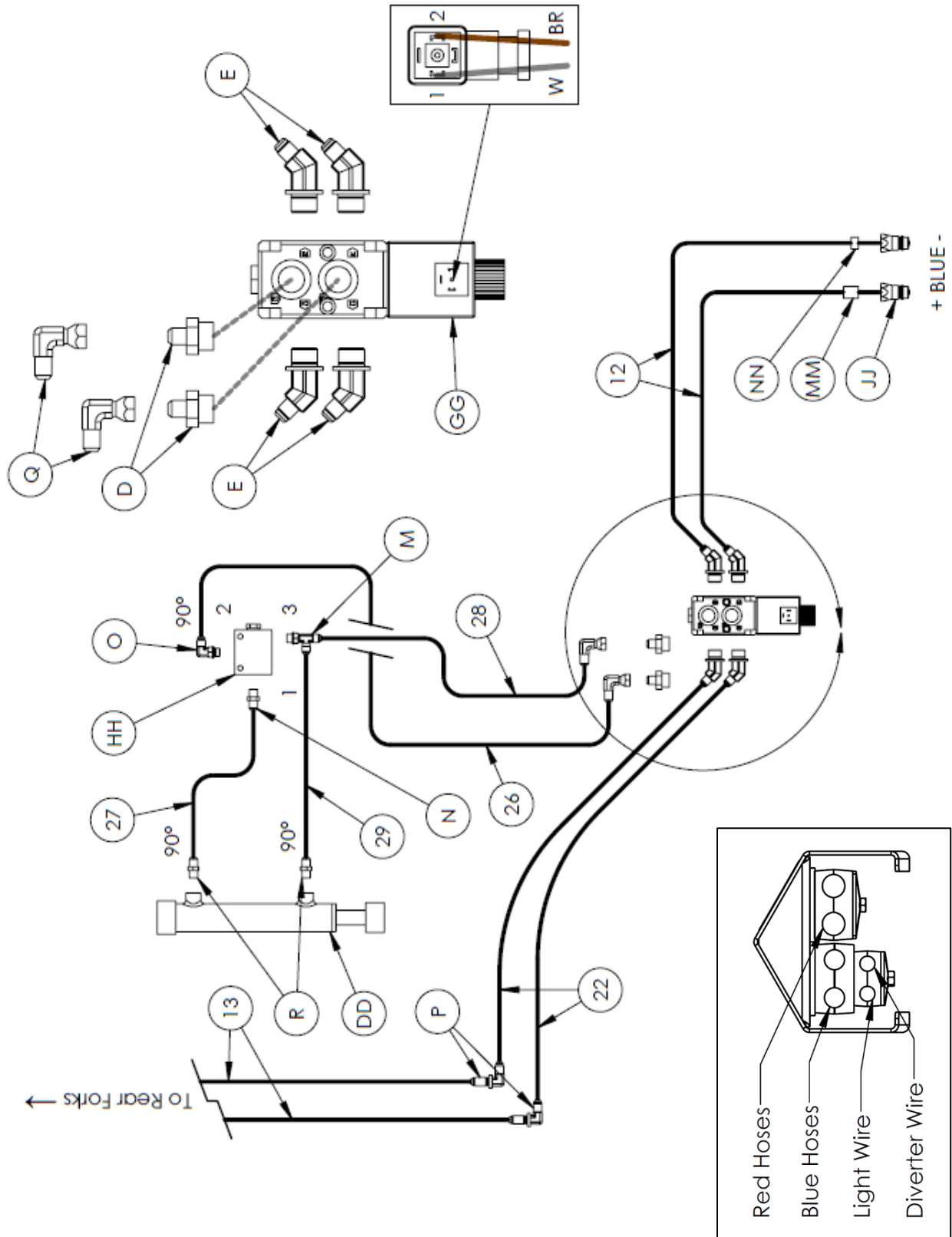

FRONT PANEL – 1 OPTION, 4-REMOTE

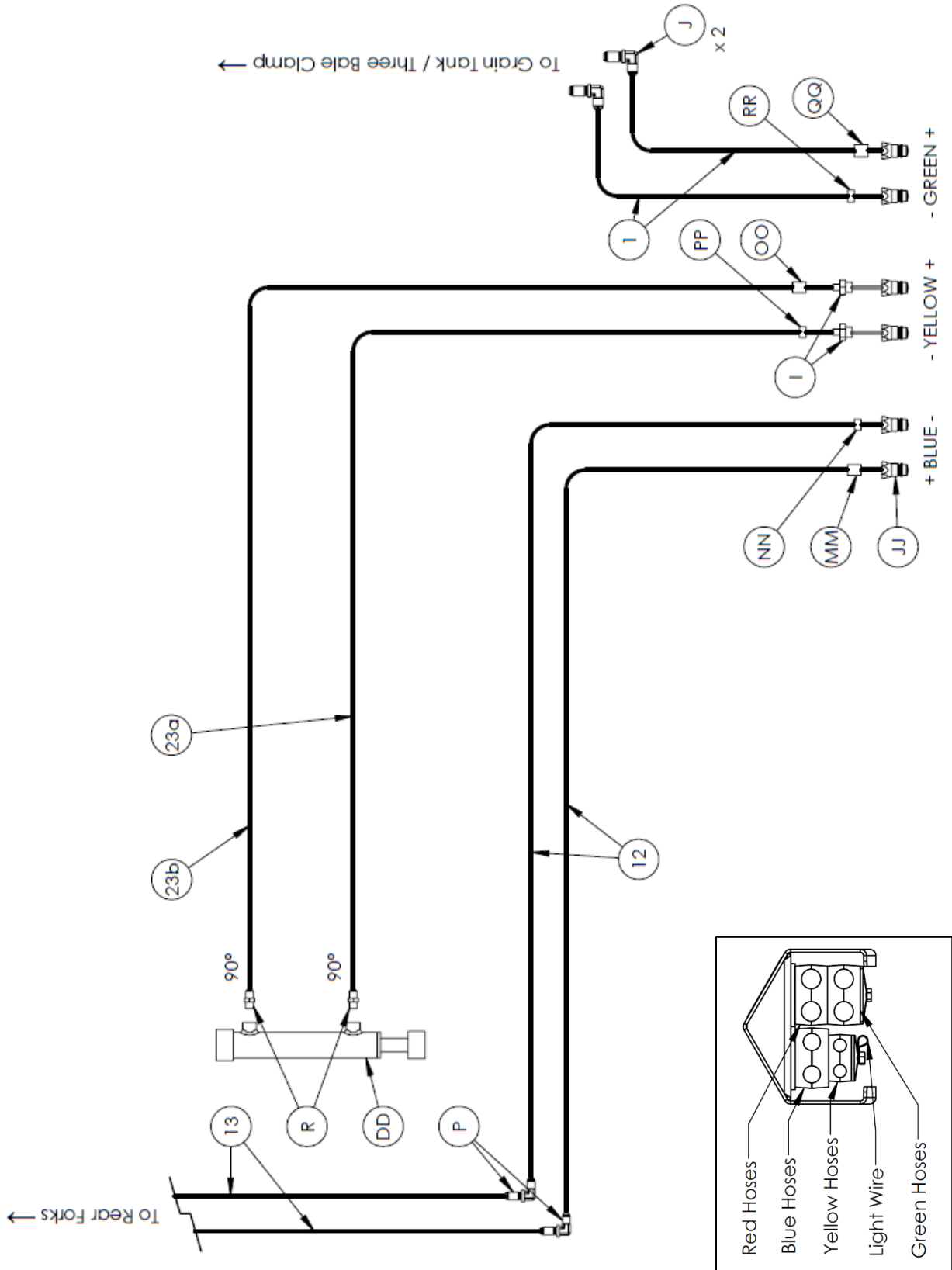

FRONT PANEL – 1 OPTION, 3-REMOTE

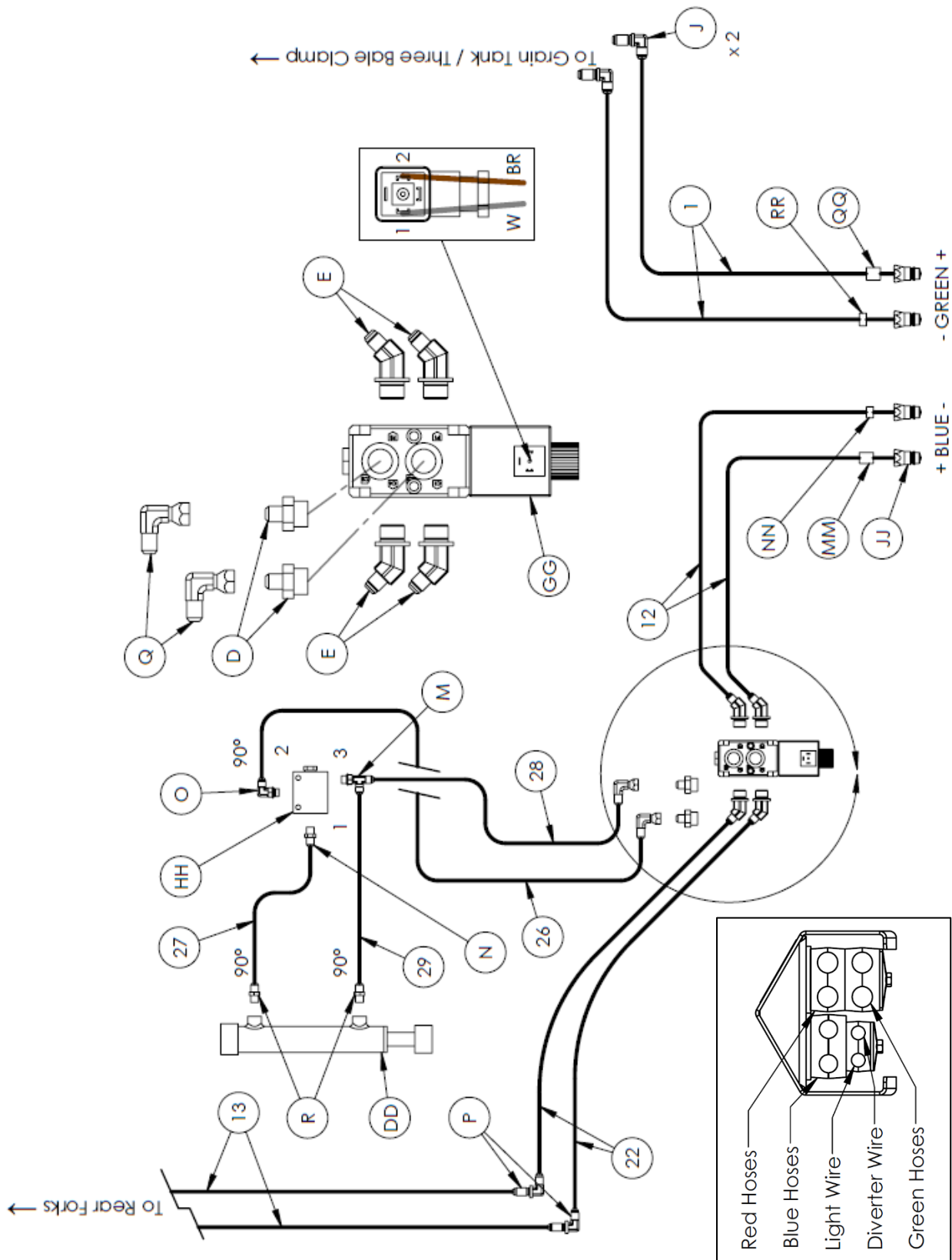

FRONT PANEL – 1 OPTION, 2-REMOTE

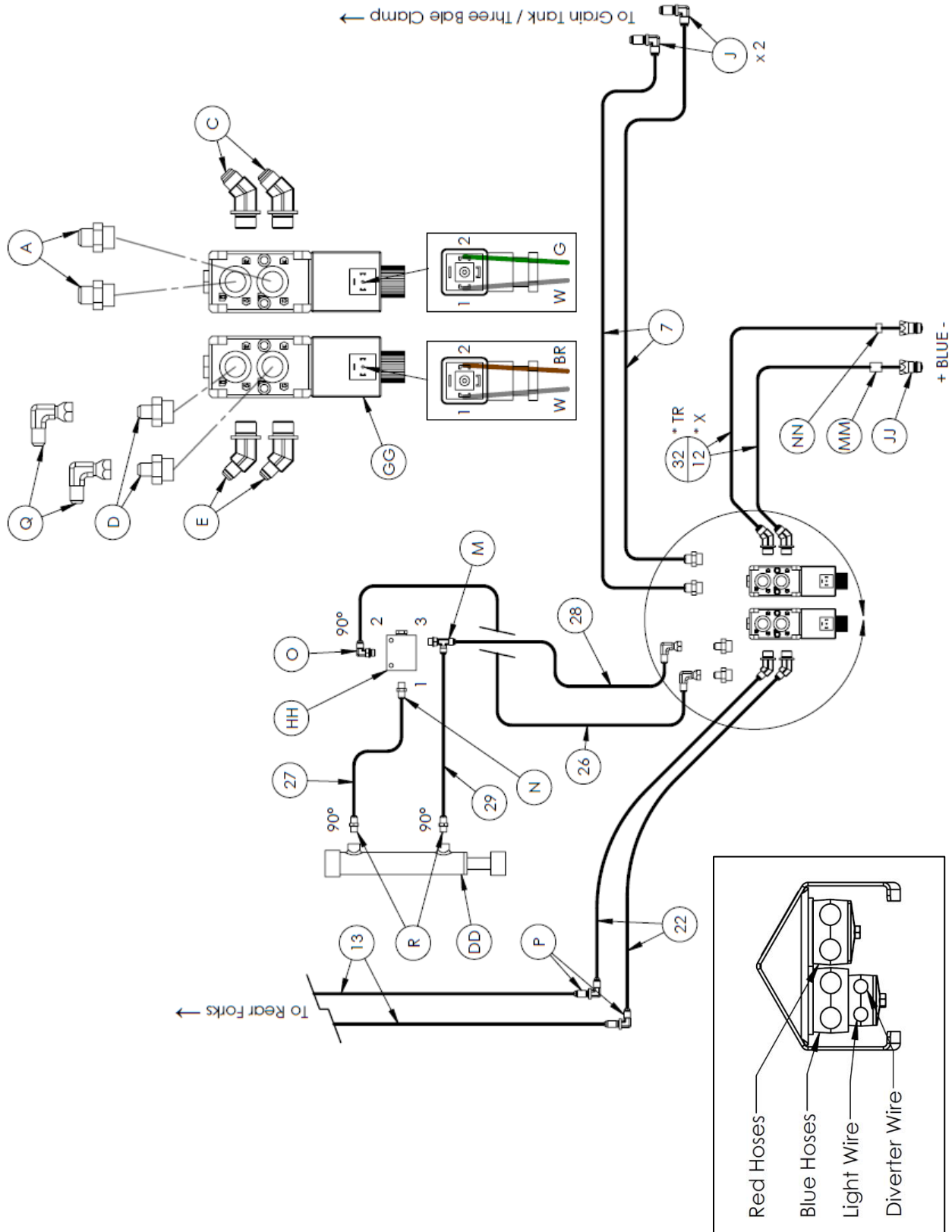

FRONT PANEL – 2 OPTION, 4-REMOTE

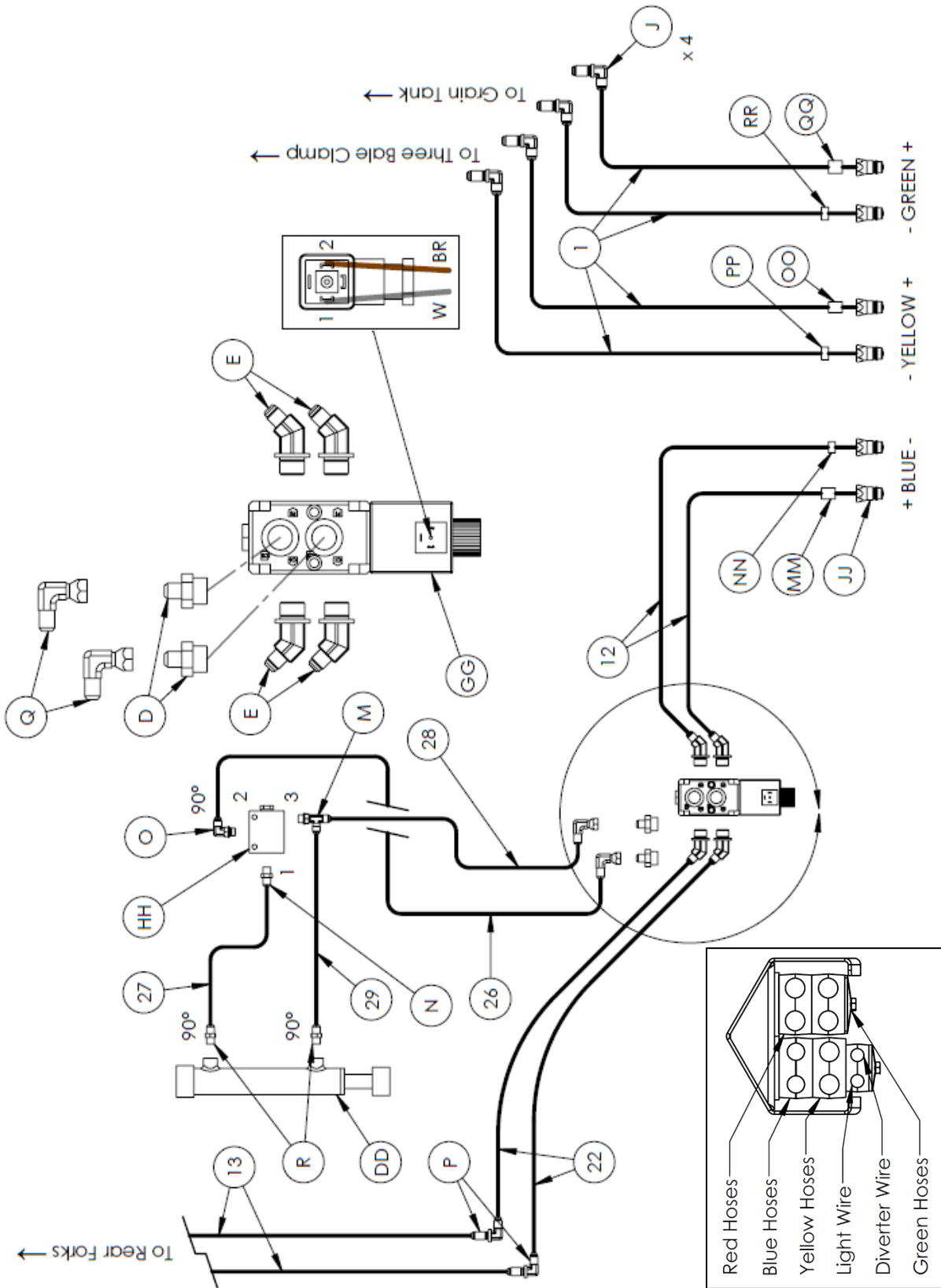

FRONT PANEL – 2 OPTION, 3-REMOTE

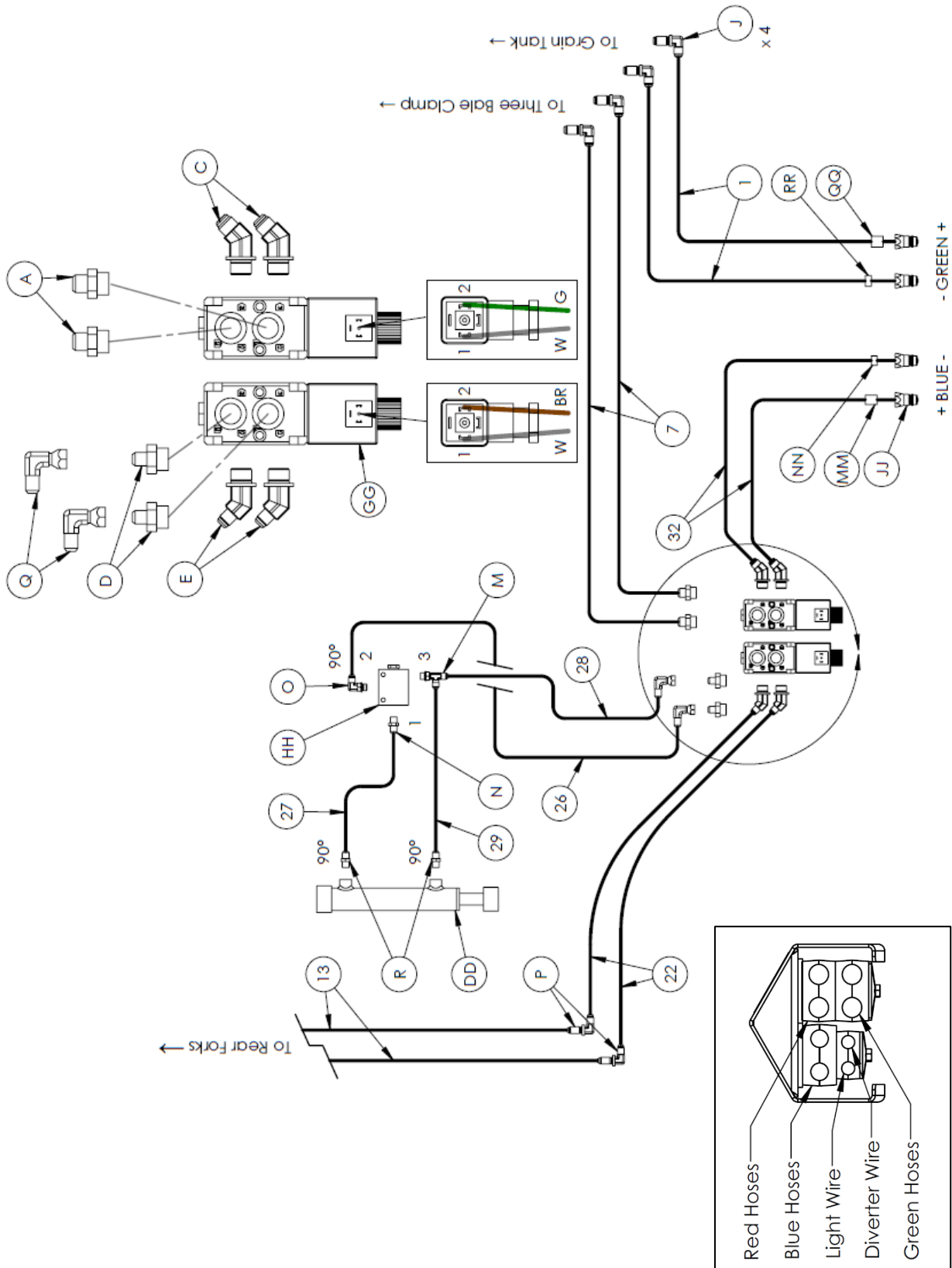

FRONT PANEL – 2 OPTION, 2-REMOTE

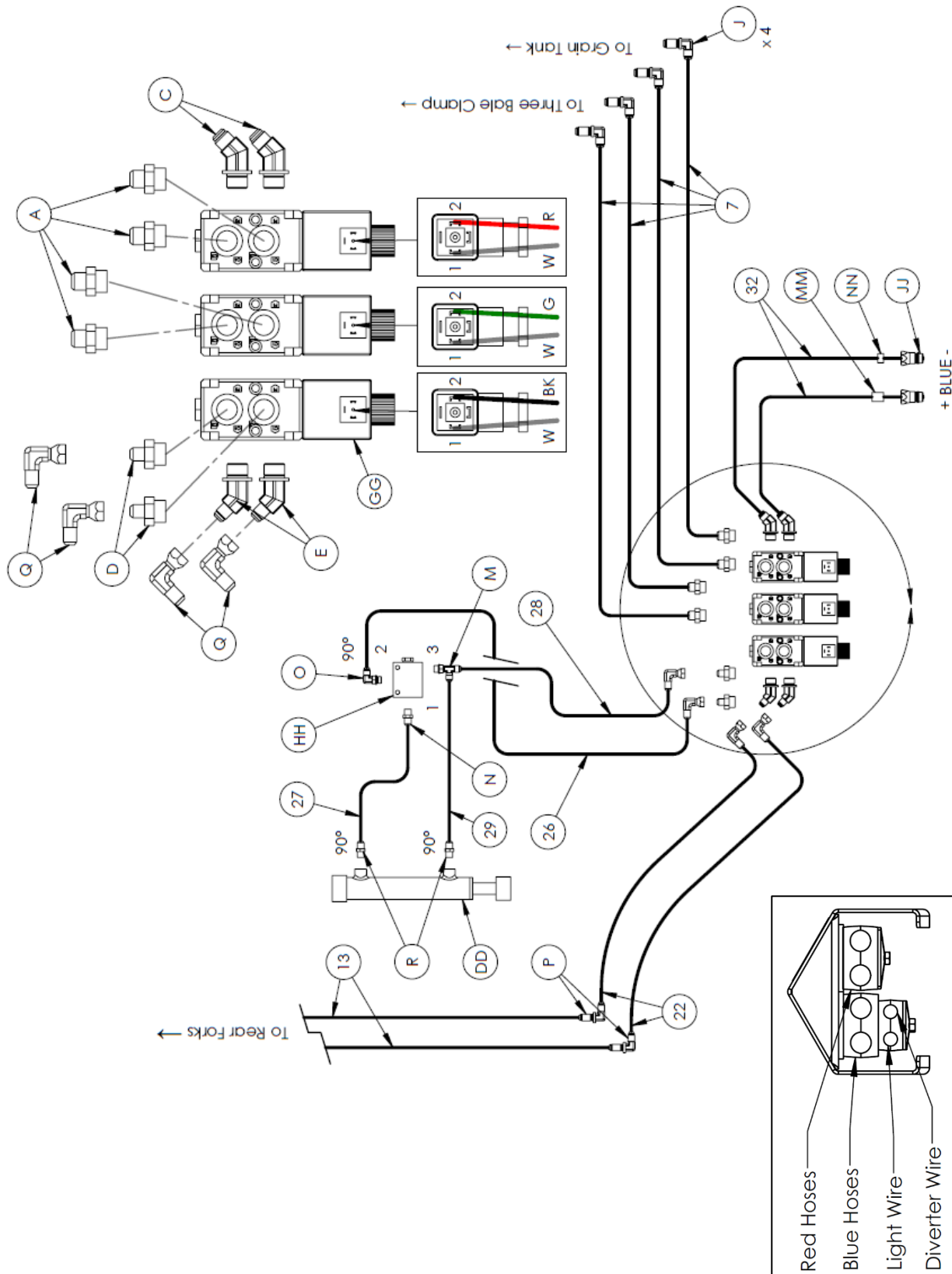

REAR FORK – S/N BK7565 & ABOVE

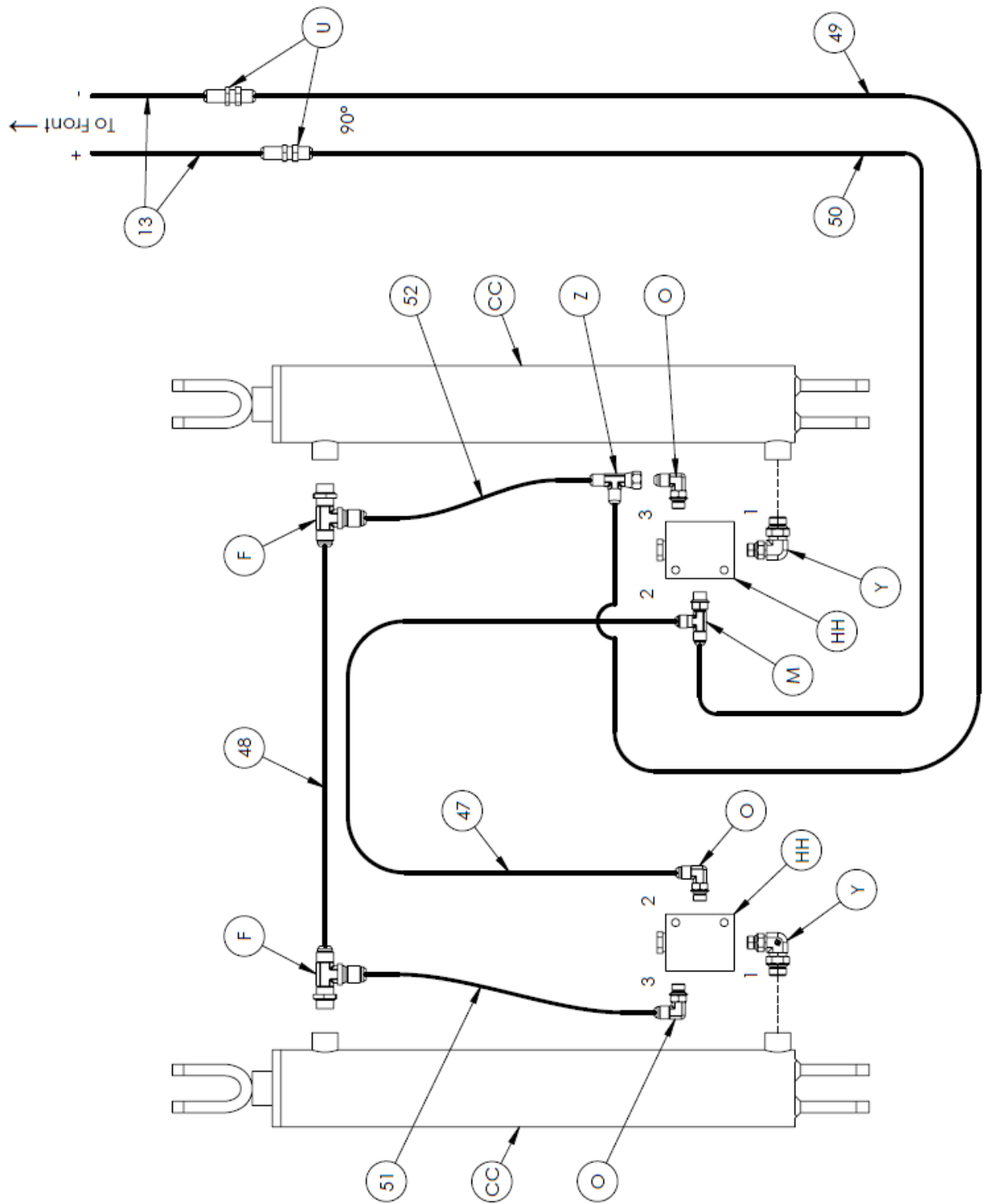

REAR FORK AND THREE BALE KIT – S/N BK7565 & ABOVE

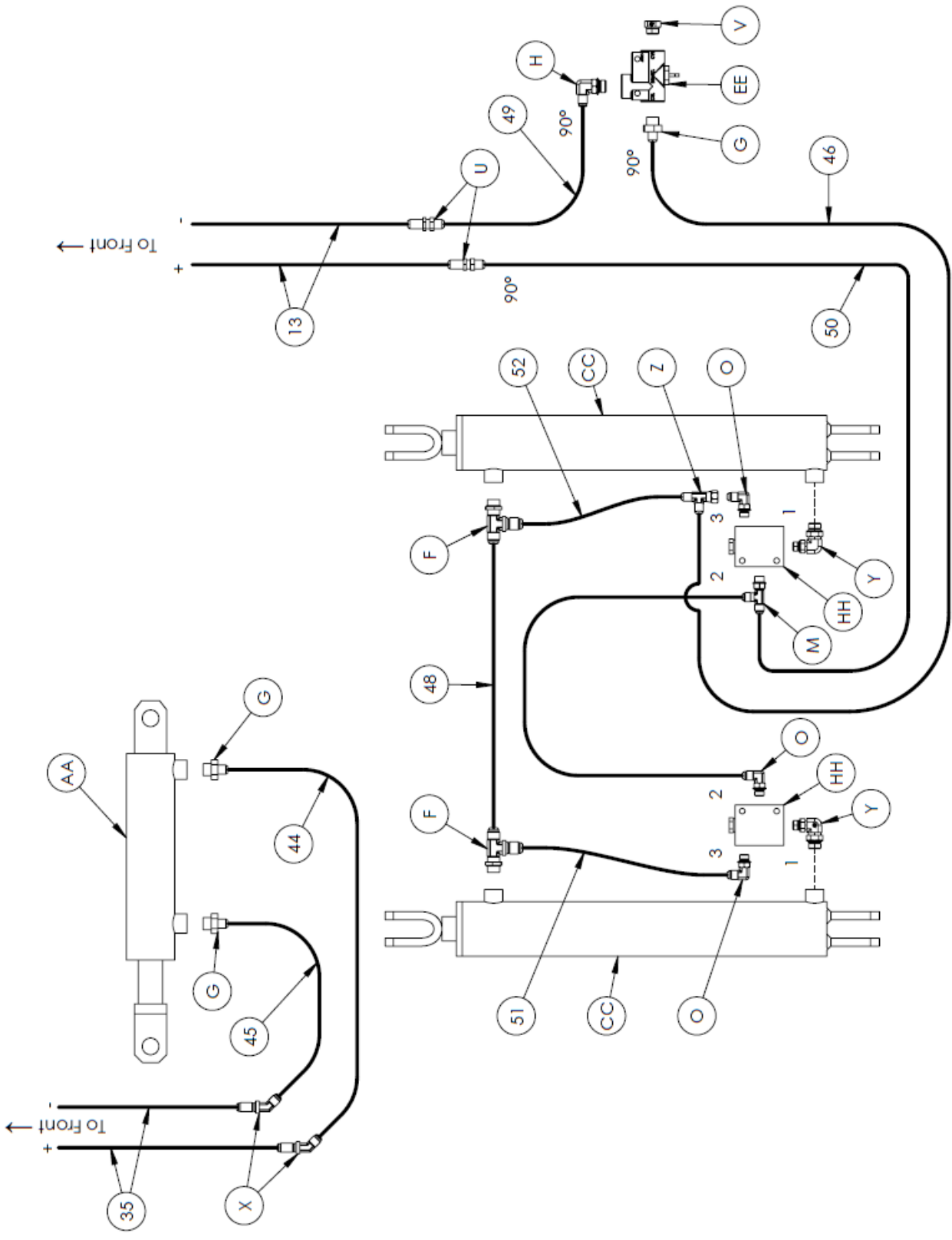

REAR FORK AND THREE BALE KIT – S/N BK7361 & BELOW

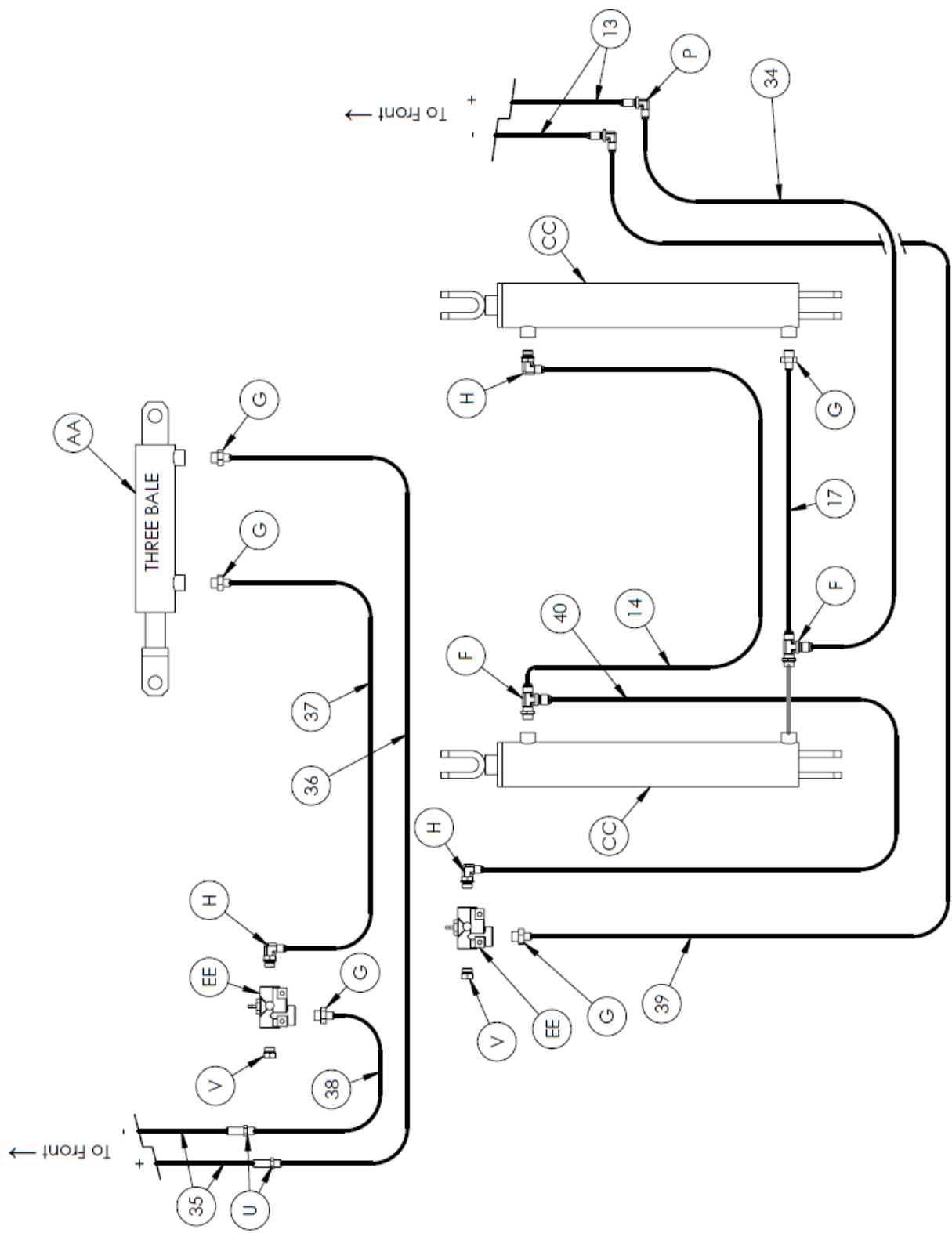

TR GRAIN TANK KIT

