



BRIDGEVIEW MFG. INC.



BALE KING 5325

***Bale Processor
with 100 Bushel Grain Tank***

Operator's & Parts Manual

Last Updated: November 2025

Bridgeview Manufacturing Inc.
P.O. Box 4
Gerald, Saskatchewan, Canada
S0A 1B0
Phone: 1-306-745-2711
Fax: 1-306-745-3364
Email: bridgeview@bridgeviewmfg.ca
www.bridgeviewmanufacturing.com

Your Authorized Dealer

Your Serial Number

The Serial Number is located the front tub panel, next to the operator manual box.

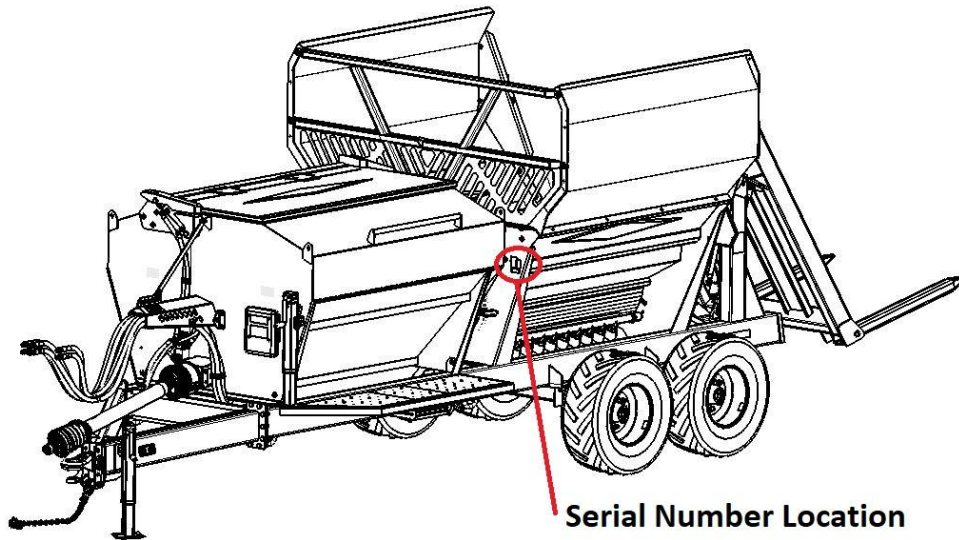

	<p>⚠ WARNING</p> <p>Failure to read and understand operator's manual & all safety signs could result in serious injury. Manual must remain with machine.</p>
---	--

TABLE OF CONTENTS

INTRODUCTION	1
Safety Precautions.....	1
Safety Decals	2
Transportation.....	4
FEATURES & OPERATION.....	6
Power Take-off	6
Hydraulics	11
Hose Holder	12
Implement Tongue	13
Torflex Axles	13
Rear Forks.....	14
Loading Bales	15
Setting the Processor.....	16
Hoop Grate Adjustment	16
Bale Roller Speed	17
Rotation Direction.....	17
Deflector	18
Grain Tank and Auger	20
Optional Fine Chop Kit.....	23
Optional Back-up Camera.....	24
SERVICE AND MAINTENANCE.....	25
Greasing Locations	25
Tires	28
Twine Removal.....	29
Gearbox and Flail Replacement Procedure.....	31
Trouble-shooting Guide	32
Features and Specifications.....	33
PARTS MANUAL.....	35

INTRODUCTION

Thank you for purchasing a **Bale King** bale processor. With the proper operation and service as outlined in this manual, the Bale King will provide you with years of trouble-free operation.

This is a complete safety, operation and parts manual for the Bale King 5325. The manual covers in detail how to safely and effectively use your new processor. The procedures outlined in this manual should be followed to ensure safe operation and longevity of your machine. The parts manual covers all parts you may need to order in case of accident or breakdown. Please read completely through this manual before beginning operation of your new machine.

Safety Precautions

The following safety precautions MUST be followed to ensure safe operation of the Bale King bale processor.

- **ALWAYS** turn **OFF** the tractor when leaving the operating platform.
- **DO NOT** stand in front of the discharge chute while the machine is running.
- **DO NOT** walk or move under the bale forks when they are in the upward position, unless the cylinder safety lock is in place.
- **DO NOT** enter the machine while in operation.
- **DO NOT** clean machine while in operation.
- **DO NOT** stick any device into the machine to clear debris while the machine is in operation.
- **ALWAYS** turn off the machine when cleaning the machine, removing twine, or hooking/unhooking the machine
- **ALWAYS** use safety chain when towing the machine on a highway.
- **DO NOT** operate if any part of the **PTO safety shielding** is missing or is not secured.

Safety Decals

Power Take-off:

The operator must obey all safety labels and must maintain the proper shielding. A high percentage of drive-line injuries occur when safety shielding is missing or not functioning properly.

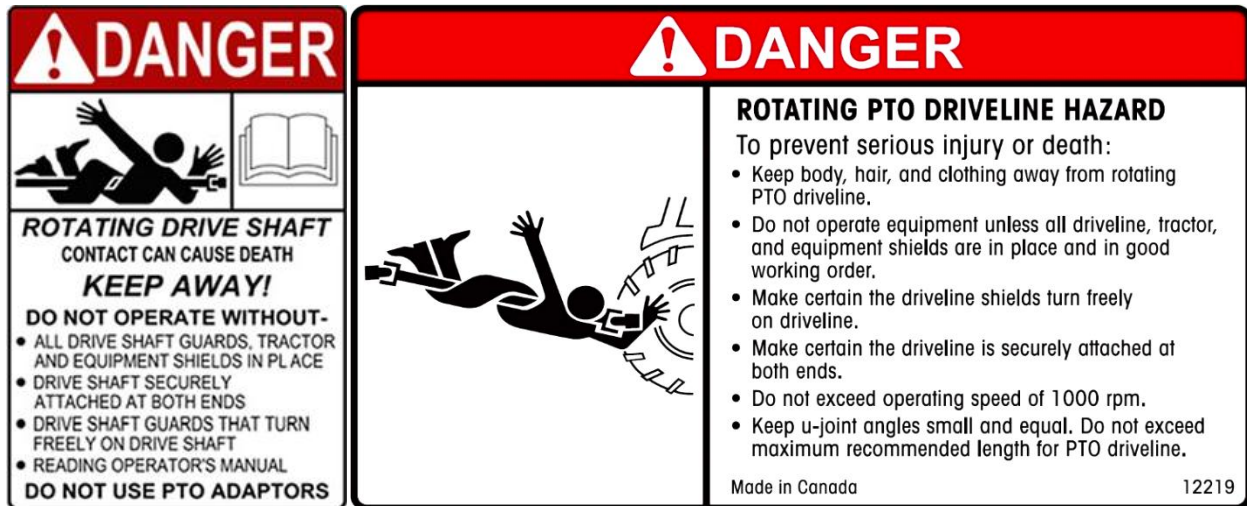

DANGER: *Contact with a rotating drive-line can cause serious injury or death.*

Discharge:



DANGER: *Do not stand on the discharge side of the machine while it is in operation.*

Rear Fork Lift Area:

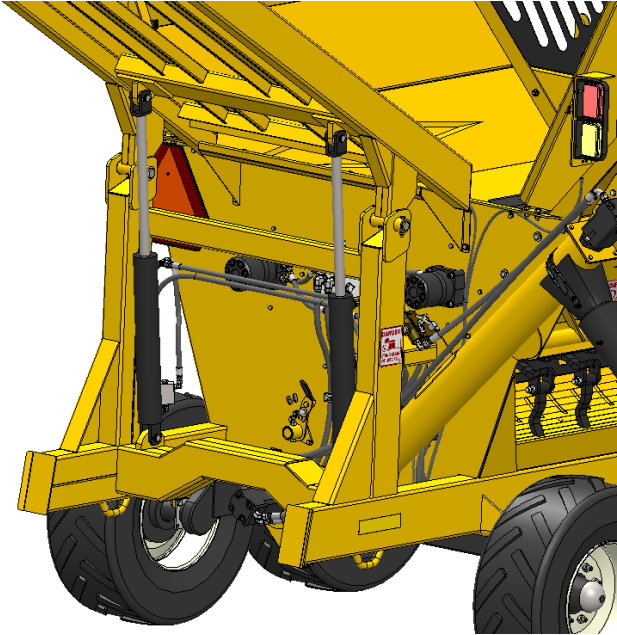

DANGER: *Stand clear of lift area. Do not stand under the forks if tractor is running or if bale is resting on forks. Automatic hydraulic safety locks are installed.*

Deflector Safety Lock:

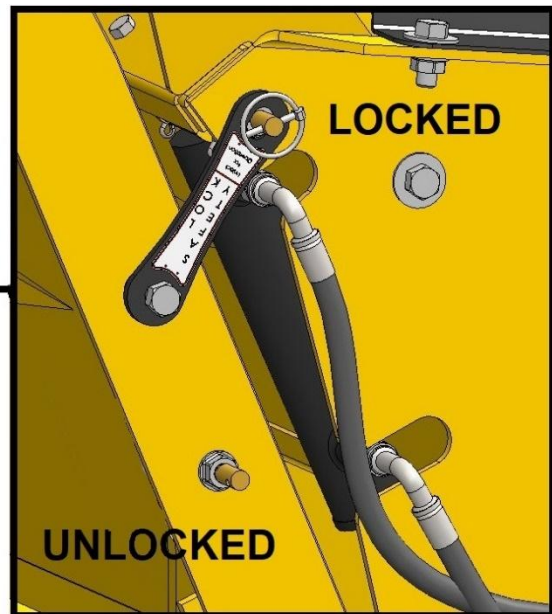

Unlock for operation, Lock for transport and storage

Transportation

The Bale King 5325 can be safely towed on public roads, provided the following precautions are met:

Weights and Dimensions

- The towing vehicle must be suitable for the weight being towed.
- Check with local authorities regarding transport on public roads. Follow all applicable laws and regulations.
- Be aware of your size and weight. Adjust your driving accordingly

	Empty	Loaded
Total Weight	7850 lb	16000 lb
Hitch Weight	950 lb	3400 lb
Length	25'-4"	29'-3"
Width	9'-10"	9'-10"
Height	10'-7"	10'-7"

Speed

Tow Vehicle Weight	Empty Processor	Loaded Processor
13000 lb and Under	32 km/h (20 mph)	Not recommended
Over 13000 lb	40 km/h (25 mph)	32 km/h (20 mph)

- The processor features implement tires and hubs and is not suitable for high speed travel
- The processor does not have brakes.
- Slow down for rough conditions, turns, and steep declines.
- If towing long distances, ensure the machine is empty (no bales in tub or on fork)
- If hauling one bale only, place it in the tub instead of on the fork.
- If hauling two bales, speed should be further reduced. Note that there will be a significant amount of weight behind the processor axle, causing more “tail whip”. This also raises the center of weight of the machine.
- Failure to heed these warning may result in loss of control or death.
- Grain applies hitch weight at approximately 50%. For example, if loading 2000lb of grain, about 1000lb of that will be supported by the hitch.

Safety Chain, Jack, PTO, and Hydraulics

- ALWAYS ensure that the safety chain is properly installed. There should be enough slack to allow for turning, but not so much that the chain drags on the ground.
- Ensure that the jack is installed in its storage position on the front of the grain tank.
- Ensure that the PTO and hydraulic hoses are properly secured
- PTO and hydraulic lines must be connected to the tractor during transport.
- If towing with a pickup, the outer PTO shaft must be removed, and the inner shaft and hydraulic hoses properly secured. The exposed end of the inner PTO shaft should be covered to protect the splines from dust/rocks, etc.

Wheels and Tires

- Check tire pressure and wheel torque. Wheels must be retorqued after 1 hr if being transported for the first time.

Tire Pressure	70 psi	Wheel Torque	125 ft-lb
----------------------	--------	---------------------	-----------

- If transporting long distances, periodically check the tires and hubs for high temperatures. If heating up, you must slow down.

Lights and Marking

- Tow vehicle must have a 7-pin round trailer plug
- Plug in lights and check for proper function and visibility (flashing amber lights, red tail lights and brake lights).
- If towing with a pickup, an adapter will be required to plug into the trailer plug. When braking, both amber lights should activate. Tail lights should always be on.
- Ensure that the supplied SMV (Slow Moving Vehicle) sign is clearly visible from the rear
- Ensure that the reflective markers are cleaned, and visible from all sides

Safety Locks

- Lift the forks all the way up. If carrying a bale, only lift enough for appropriate ground clearance.
- Ensure that the deflector safety lock is installed

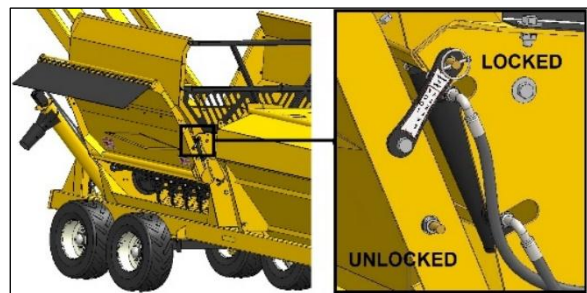

FEATURES & OPERATION

Power Take-off

The Bale King bale processor has a PTO shaft which is splined on both ends. The implement end uses a 1-3/4"-20 spline with wedge lock bolts. Install onto the gearbox and tighten the wedge bolts. The bolts should be torqued to **160 ft-lb** and re-torqued after 8 hrs of use.

The tractor end comes standard with a 1-3/8"-21 spline quick detach constant velocity joint. An optional 1-3/4"-20 spline yoke is available through your Bale King dealer.

The Bale King 5325 Processor has an additional driveshaft travelling from the front of the unit, through the tank and to the front of the gearbox. This shaft has a male 1 3/4"-20 spline end on the PTO shaft end, the other end features a 1 3/4"-20 spline yoke with grease fittings.

<p>MAXIMUM 150 HORSEPOWER TRACTOR PTO</p>
--

NOTE: *Spread yokes and twisted drive shafts are signs of **OVERLOAD**, not a manufacturer's defect and therefore not covered by warranty.*

- **DO NOT** operate the machine using a spline adaptor. Use of adaptors will **void warranty** due to damage caused to the tractor PTO, PTO driveshaft, or implement.
- **DO NOT** operate at 540 rpm, or use any kind of adaptor to connect to a 540 rpm spline.
- **ALWAYS** ensure that the PTO shaft is attached securely to the tractor. When the processor is not hooked to the tractor, store the shaft on the PTO holder.
- **DO NOT** transport the processor without securing the PTO shaft. See next page for securing instruction.
- **ALWAYS** ensure that the drawbar is adjusted to **16"** from the end of the tractor PTO shaft to the center of the hole in the drawbar.

Operation

To engage the rotor for processing a bale, be sure the PTO shaft is properly connected to the tractor. Engage the PTO at idle. After the PTO is fully engaged, increase PTO speed until it reaches 1000 RPM.

The processor must not run at any speed less than 1000 PTO RPM as it may result in the flails springing back against the rotor after they come in contact with the bale. This “*backslap*” may cause flails to fatigue and excessive vibration which may cause the bearings to fail. Bales may be dumped into the tub while the rotor is stopped or while it is running.

Shear Bolt

All new Bale King processors are equipped with a **shear bolt** clutch located at the implement end of the PTO shaft. The correct size shear bolt is **3/8 x 2” Fine Thread Grade 5 with Stover Lock Nut**. Any other size or grade will **damage** the shear assembly. Spare shear bolts are shipped with each new machine and are stored along the front top lip of the tub.

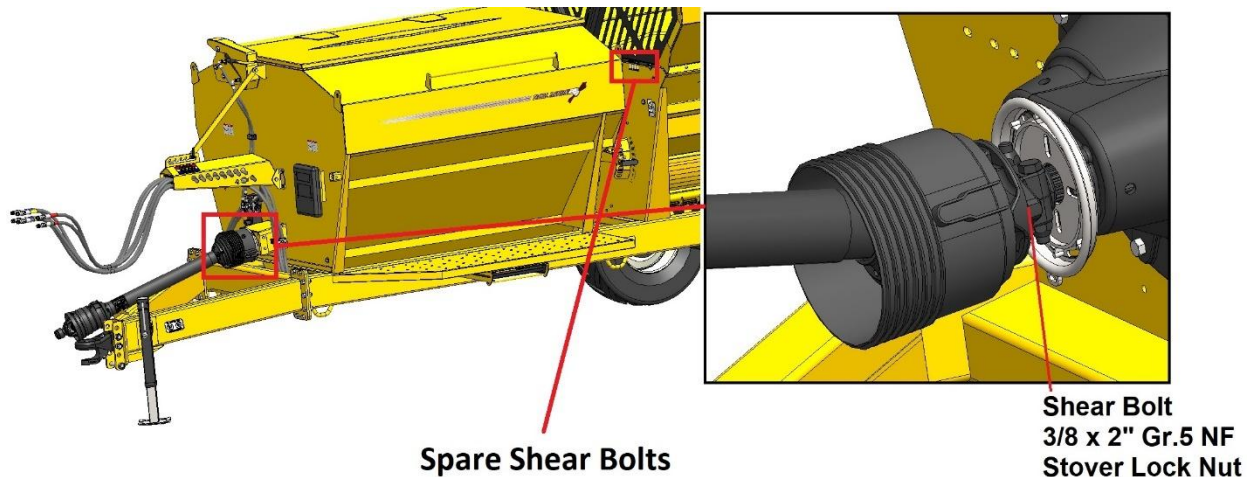

If your shear bolt is shearing excessively, you may be over-loading the machine. If this occurs raise the grate assembly to make the machine less aggressive, or roll the bale more slowly. **Always ensure that your machine is running at 1000 PTO RPM.**

NOTE: *Please consult your local dealer to help pinpoint any problems.*

PTO Holder

A PTO shaft holder is standard with your new Bale King, for safe storage of the PTO shaft when the processor is not in use.

When unhooking the PTO shaft from the tractor, retract and then swing the PTO to the right to rest the PTO on the holder.

DO NOT transport the machine with the PTO in the holder. Slide the outer PTO shaft out and secure elsewhere. When transporting, fasten the inner PTO shaft to the machine and cover the open splined end.

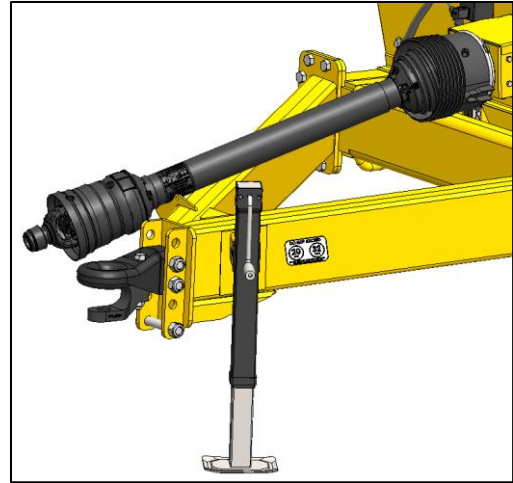

PTO Use and Maintenance

Shut **OFF** the tractor engine and remove the key before doing any maintenance on the machine. Use **ONLY** genuine **Weasler** parts when replacing any worn or damaged PTO components.

Length:

Confirm the minimum and maximum working lengths of the drive-line. The telescoping tubes must overlap at least 1/3 of their length when in use. The PTO is designed to be used with a drawbar length of 16" from the end of the PTO shaft. Adjust your tractor accordingly.

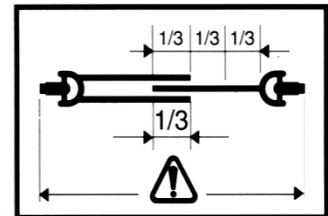

Shielding:

Be sure that the shielding is not damaged and rotates freely on the drive shaft.

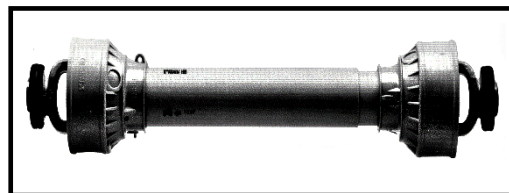

Working Angles:

Constant Velocity joints can operate up to 80 degrees for short periods of time. Do not operate for long periods on sharp angles.

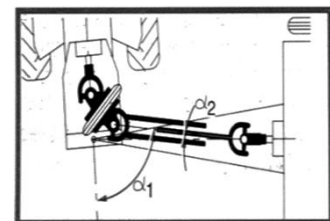

Attachment:

Be sure the drive-line is properly attached and all bolts and screws are tight on the implement input shaft and on the tractor PTO shaft.

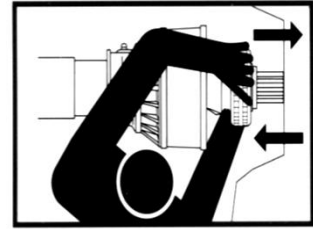

Storage:

When not in use, cover or protect the drive shaft from the weather. When removed from the machine store both halves together to prevent damage. Check all components for proper function and lubrication before use.

**BEFORE ATTEMPTING ANY REPAIR PROCEDURES,
ALWAYS USE APPROPRIATE EQUIPMENT SUCH AS
SAFETY GLASSES, SAFETY SHOES, AND GLOVES**

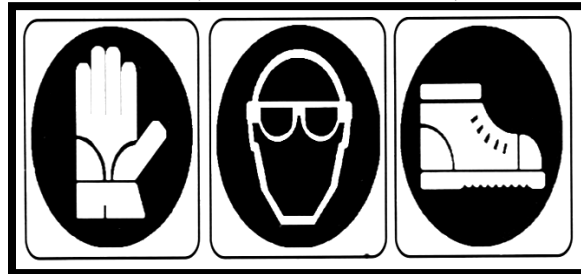

Shield Removal:

- To remove the shield, pop out the red snap, then rotate the guard on the bearing to line up the three tabs with the openings and pull it off away from the knuckle joint.
- Remove the nylon bearing from the shaft by spreading it open.



Shield Assembly:

- Be sure to lubricate the groove in the inner yokes where the shield bearing rides. Reinstall shields in the reverse order that they were removed.

Lubrication:

- Be sure to follow the lubrication timeline as outlined on page 25 **Error! Bookmark not defined..**

- Use low temperature grease if operating in cold temperatures. This will allow the PTO splines to slide much easier in these conditions.

Hydraulics

WARNING: *Pressurized hydraulic fluid can cause serious injury.*

- When working with hydraulic equipment, eye and hand protection should be worn.
- Do not test for leaks with bare hands.
- Relieve any pressure before removing a hose or fitting.
- Never work under components raised by hydraulic equipment unless supported externally.



There are three sets of hydraulic hoses to connect to the tractor. Each hose has a coloured marker to identify its function. They should be connected at best convenience for the tractor's controls. Note that the hoses are paired by colour and the following tables show the operation when pushing oil into the hose with the longer marker.

Control Box	Hose Function		
	"AUXILIARY"	"FORK"	"DEFLECTOR"
Long Blue	Open Grain Tank Lid	Lift Rear Fork	Lift Deflector
Long Red	Rollers Rotate Clockwise		
Long Yellow	Discharge Grain		

The Bale King 5325 processor has 2 diverter valves which allows it to operate using only 3 hydraulic remotes. The fork, deflector, and grain tank lid functions are then controlled by a cab-mounted switch box. This box must be wired up to the tractor's electrical system. You may use the provided plug to plug into the accessory outlet. If this is not available, the plug can be disassembled, and wired as necessary.

A 4-pin plug is used to power the diverter valve on the processor. If no power is supplied, the hydraulics will still control the rear forks, but the deflector will not be functional. If the switch in the tractor is activated, the deflector can be controlled.

Always set the tractor's hydraulic flow at a lower rate and adjust it upward until the desired speed is reached. Excessive oil flow may damage the flow divider cartridge.

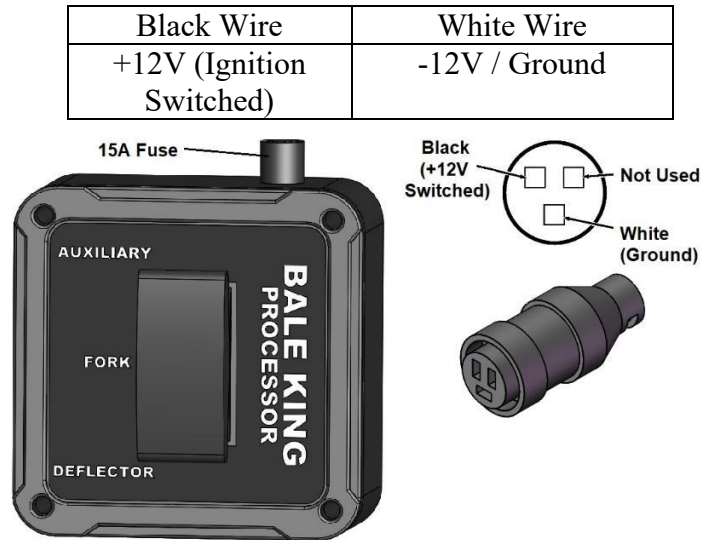

Hose Holder

The hydraulic hoses may need to be adjusted to avoid damage from rubbing on the PTO shaft. This can be done by lifting or lowering the hose holder. Loosen the pin handle, then lift the end of the hose holder to drop the pin into the slot. Then adjust the height as desired and catch the pin into the desired notch. Finally, retighten the pin handle to prevent it from switching positions if the machine bounces.

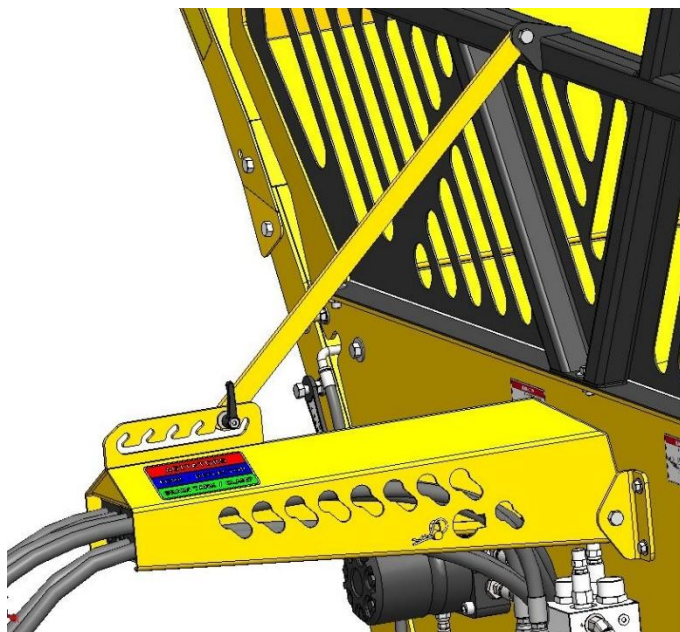

Loosen handle
Lift end of holder
Slide pin in slot
Choose setting
Tighten handle

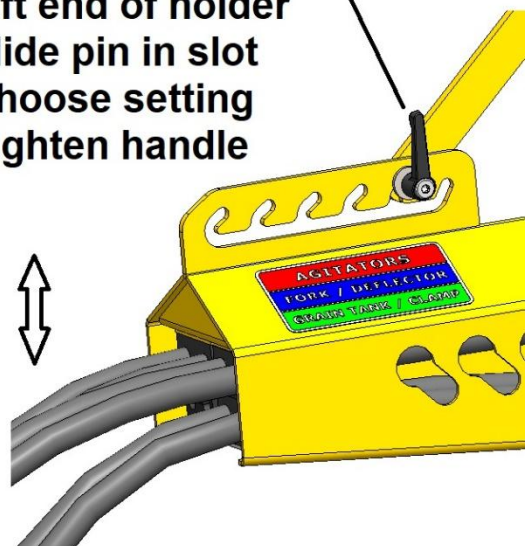

Implement Tongue

The adjustable hitch on the Bale King features a cast single tongue with optional clevis insert (**BMI #25540**). This allows for use with tractors equipped with a hammer strap or with a single drawbar. It also allows the machine to move independently over rough terrain without bending the draw pin.

- Make sure that the drawbar is set to **16 inches** behind the PTO shaft for proper PTO length.
- Adjust the hitch height to match the tractor drawbar height as close as possible. When properly adjusted, the frame rails should run level.
- **DO NOT** install the clevis insert if using a tractor with a hammer strap as this may bend the hitch pin.
- **ALWAYS** connect the safety chain during road transport

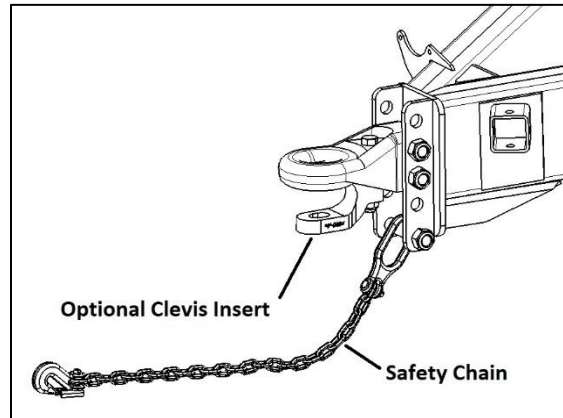

Torflex Axles

The Bale King 5325 features a pair of Torflex axles, which provide suspension and allows a smooth ride over rough terrain.

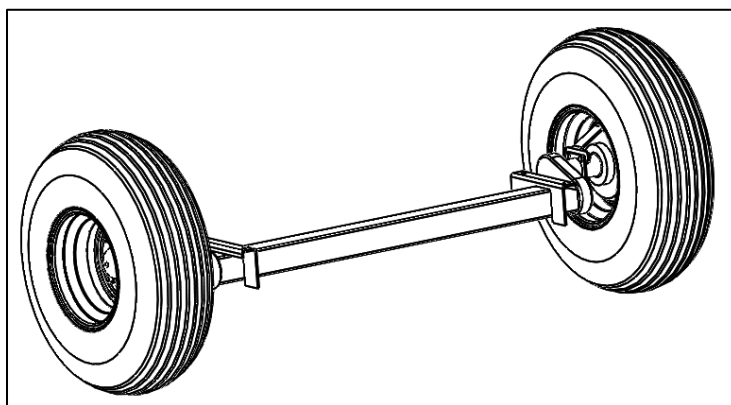

Rear Forks

The rear fork bale tines can be adjusted side to side by removing the pin connecting the tine to the machine and replacing the tine in the other available gap. The widest position is recommended for all situations, except for the smallest bales. Always use tines in the same position on either side to keep the load on the forks and cylinders balanced.

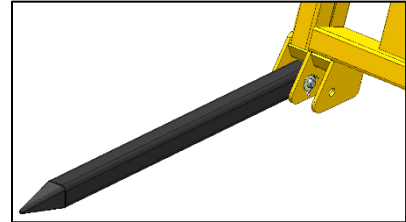

For transport, and safety when working under the forks, the Bale King 5325 is equipped with hydraulic safety valves that do not allow the forks to come down without hydraulic pressure. Lowering the forks using the tractor controls overrides this valve and allows the forks to lower. Never stand under the forks. When greasing or servicing around the rear end, the forks should be down. Never attempt to loosen or replace hydraulic hoses while the forks are up.

Loading Bales



When loading bales into your Bale King bale processor, the following procedure should be followed:

- Position the tractor and the Bale King so as to be lined up to back straight into the row of bales.
- When close to the bale, lower the forks completely (you will feel a light vibration as the forks bottom out against the frame.)
- Back completely under the first bale.
- Allow the tractor to move forward while lifting the bale, because the bale fork moves away from the machine while loading.
- If you are loading from the same row you can dump the bale into the machine and back straight into the second bale. If you are going to a different stack for the second bale only raise the first bale enough to clear the ground. Move to the next row and align the machine to the bale before dumping the bale into the tub. This gives you good visibility to line up to the second bale.
- Once you have the first bale in the tub and the second bale on the forks, raise the bale fork about 1/4 of the way up. You can now transport to your feeding or bedding area to begin processing.

Note: *Carry the bale as low as possible to lessen the stress on the cylinder shafts. Carrying the bale too high may bend hydraulic cylinder shafts.*

- When the first bale has been processed, it is common practice to leave the rotor running at full speed when loading the second bale into the bale chamber from the rear forks. However, the rollers should be stopped during loading.

Setting the Processor

Processing speed must be balanced with overall aggression and vibration levels. Excessive continuous vibration may affect the service life of the processor. Processing times of 1-2 minutes are considered normal in dry bale conditions. Extended times are expected in tougher conditions such as high moisture feed, frozen, or misshapen bales. The processor may need to be adjusted for each type of bale for optimal performance. ***Processing a bale too rapidly may cause excessive vibration and driveline damage.***

There are 3 main components to setting the processor:

1. **Hoop grate height:** Adjusts how far the flails protrude above the grate
2. **Bale roller speed:** Adjusts the feed rate to the rotor
3. **Bale rotation direction:** Controls the feed direction over the rotor

Hoop Grate Adjustment

There are eight adjustment settings for the hoop grate on the bale processor. These settings vary the aggression and length of cut. To adjust, pull the spring handle outward, then swing the handle “UP” for a more aggressive cut, or “DOWN” for less aggression. Then release the spring handle to engage the pin in the desired hole.

When there is a bale in the tub, the bale’s weight will be placed on the hoop grates, making adjustment more difficult. Adjust the machine when it is empty when possible.

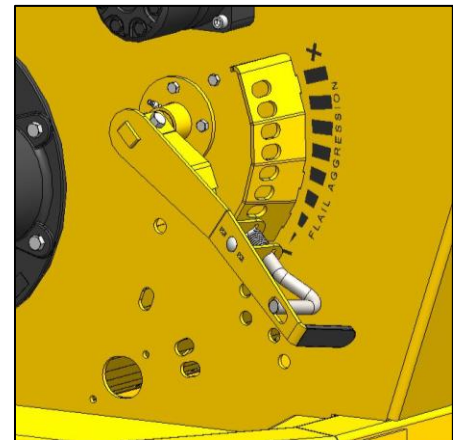

- **Position #1 (Bottom):** Highest grate setting for finest cut and slowest rate of feed. Used for tough processing feeds such as silage bales, or other wet materials.
- **Position #2-6:** Normal operating range. Machine gets more aggressive as handle moves “up”.
- **Position #7-8 (Top):** Lowest grate positions, most aggressive, fastest rate of feed.

The Bale King should be adjusted according to bale conditions to achieve a rate of feed of approximately **1 to 2 minutes**. Light, brittle material such as wheat straw may allow faster processing while tough stringy material such as silage, slough hay, green feed, or flax will require slower processing. Hoop grate adjustment should be checked periodically.

NOTE: *Upper grate position should be approximately 0" flail protrusion. Lower grate position should allow 3" flail protrusion.*

Bale Roller Speed

The Bale King is equipped with a flow divider/combiner and two hydraulic motors for turning the bale. Proper roller speed is critical to smooth processing. Roller speed is adjusted via your tractor's flow control. Set a one-minute timer and count revolutions of a roller paddle. 40 RPM is a typical starting point. Speeds of 30 to 45 RPM are considered normal depending on bale conditions.

If vibration is excessive, slow the rollers and raise the hoops as necessary to adjust. Excessive roller speed will overload the processor and potentially cause the shear bolt to break. Extended periods of overload may cause driveline damage. Excessive roller speed will also increase loose material build-up on the non-discharge side of the processor. Proper roller speed balances the feed inflow to the rotor with its discharge rate.

Rotation Direction

Turn the bale counter-clockwise (as viewed from the tractor seat) as much as possible. Reverse only as necessary to clear loose material. When turning counter-clockwise, feed flows over the hoop grate, through the rotor, and out the discharge area. When turning clockwise, material is fed both over the rotor and over the non-discharge bale roller into the rotor. This can cause overloading and vibration.

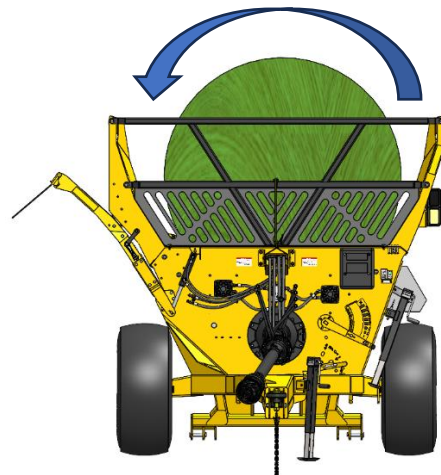

Deflector

The Bale King 5325 is equipped with a hydraulic side deflector to change the discharge distance and distribution. It also comes with a flipping rubber flap for superior control of the spread pattern.

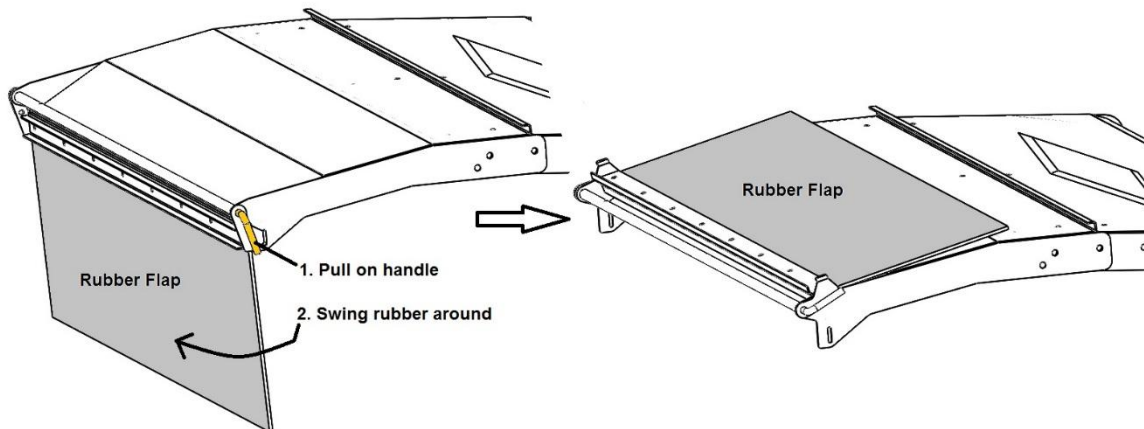

Moving the deflector to the **down** position and flipping the rubber down (above left) will allow the hay to be laid in a windrow, or bunk feeder. Swinging the deflector **up** will allow you to spread straw out over a large area. If you also flip the rubber up (above right), you will be able to "fine tune" the discharge, to control the height and distance.

To flip the rubber, simply pull on the handle and swing into position. Then push the handle so that the tabs catch in the notches and lock into place.

The Bale King 5325 deflector will bunk feed up to a distance of 35" from the tire when in the lowest position. When the deflector is not folded, the transport width of the machine is 9'-10".

For transport and storage, the deflector lock should be put in place by swinging the lock as shown and fastening with a lynch pin.

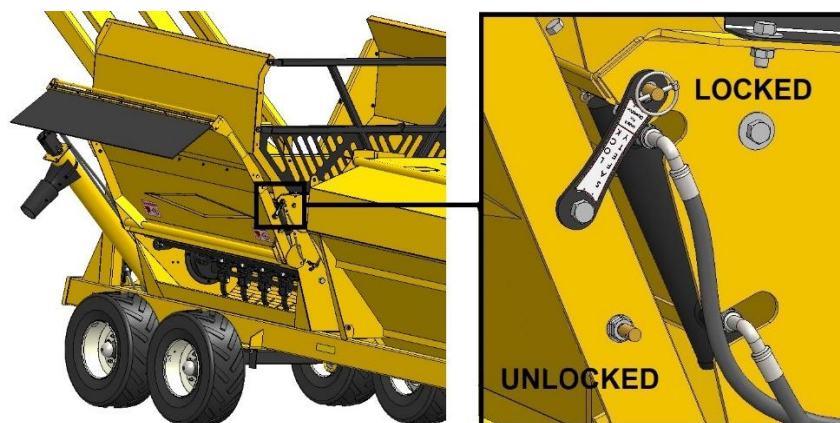

The Bale King 5325 deflector also has the ability to fold for more compact long-term storage or long-distance transport.

- Move the deflector to its lowest position
- Remove the 7 top carriage bolts from the deflector.
- Loosen all the 4 bolts on the front and back of the deflector.
- Raise the deflector to its highest position with the hydraulics. Remove the bolts closest to the machine center (both front and back) and swing the outer deflector down.

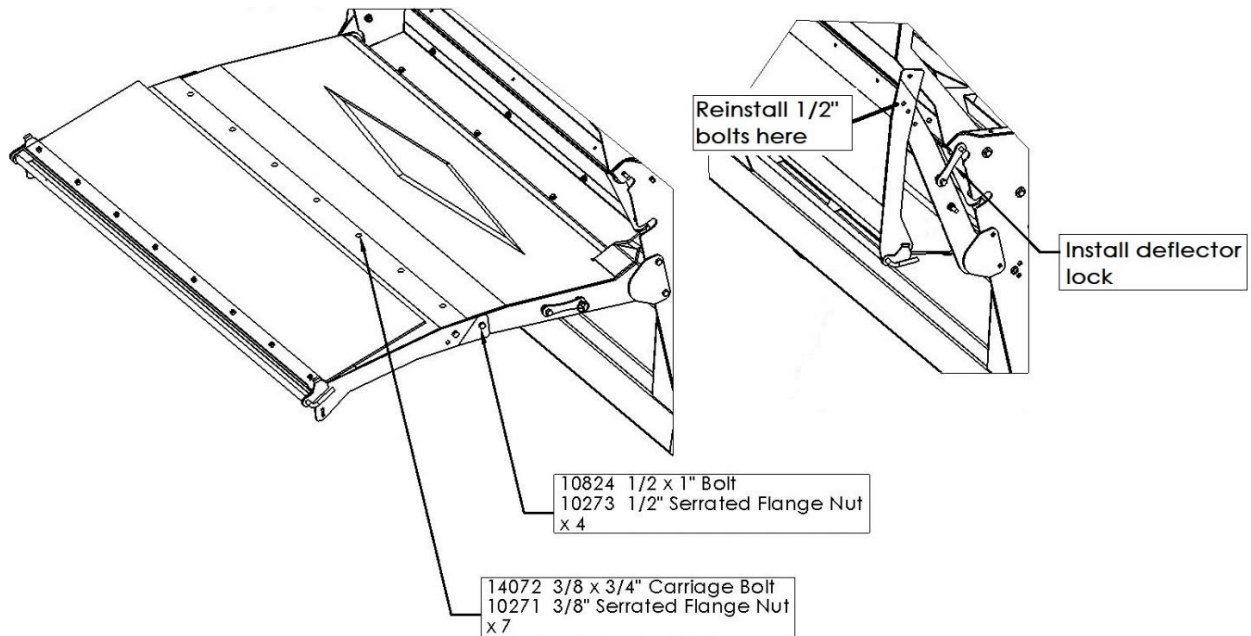

BE CAREFUL WHEN LIFTING THE DEFLECTOR WITH THE OUTER PANEL ABLE TO PIVOT TO AVOID CONTACTING THE TIRES.

Grain Tank and Auger

Overview

The Bale King 5325 processor features a 100-bushel grain tank with a hydraulic lid opener. An auger at the bottom of the grain tank brings the grain from the grain tank, under the processor tub, and into a boot where a second discharge auger lifts the grain up and out of the spout.

Grain Tank

The grain tank lid is opened by switching the in-cab control box switch to the “Auxiliary” function and activating the hydraulic controls. If any considerable weight is on top of the lid, the lid should not be opened until the debris is cleared off. Any considerable loads on top of the lid, including snow, could result in a bent lid if the lid is forced open. This type of damage is not covered by warranty. The operator should also watch for any obstructions before opening the lid. Once the lid is open the operator can drive under the auger. While the tank is being filled the operator can move the tractor in forward or reverse to fill the tank evenly. Levelling off the grain helps maximize how much grain can be put in the tank.

A platform is placed on the side of the machine so the operator can view the tank level from outside. The ladder slides in and out from below the platform. The ladder should be slid into storage when driving. Care should be taken when getting on and off the platform. Use the provided handrail to prevent slips. Ensure the platform and ladder area are free of tripping or slipping hazards. Never enter the grain tank when it is full – grain entrapment is a potential hazard. Never enter the grain tank when the tractor is running, contact with running augers, which could cause loss of limbs or life.



Auger Operation

The augers are actuated by the hydraulic remote connected to the yellow banded hydraulic hoses. The auger hydraulics have a one-way check valve that only allow hydraulic flow in one direction so the auger only turns in one direction. If the augers do not move when the remote switch is moved, switch directions or switch the hoses on the tractor. The augers should be attached to a remote that is detented (locks into flow position).

The auger speed can be adjusted by adjusting the flow control valve which is located on the right fork upright arm at the rear of the machine. A setting of 0 will result in no auger movement. A setting of 10 will result in the fastest auger speed possible. To adjust, turn the plastic screw counter clockwise to unlock, then rotate the handle to the desired position, and retorque the plastic nut to hold in place.



If the operator wishes to feed at a certain feed rate the auger speed can be adjusted to come reasonably close to the desired rate. The operator must first measure the discharge volume or weight per unit of time. This can be done by running the tractor at bale processing engine speed (1000 PTO RPM) and timing how long it takes to fill a small container or pail full of grain. The grain is then either weighed or measured for volume.

This process can be repeated until the desired discharge rate is achieved.

Tank and Auger Clean-outs

A tank cleanout is located at the rear underside of the grain tank and under the boot where the two augers meet (see pictures to the left). The cleanout doors can be removed by removing four 1/4" bolts. The auger can then be ran for a short period to dump any grain out of the cleanouts. With the tractor off and the hydraulic lines disconnected, the operator can climb inside the tank and sweep or shovel any grain down and out of the tank cleanout. The boot can be cleaned out by reaching inside and pulling out any grain. Compressed air could also help cleaning the boot as long as the operator observes all compressed air related hazards. It is a good idea to clean the tank and auger system out periodically or before long term storage.



Optional Fine Chop Kit

5325	Fine Chop Option	BMI #36155
------	------------------	------------

The Bale King 5400 processor has an optional fine chop knife kit available to install into the lower tub area. This option is available if you desire a finer cut on the material which you are processing such as slough hay and silage bales.

It is recommended that the knives be disengaged when bedding straw as it will affect your spread pattern. Adjust the machine as needed.

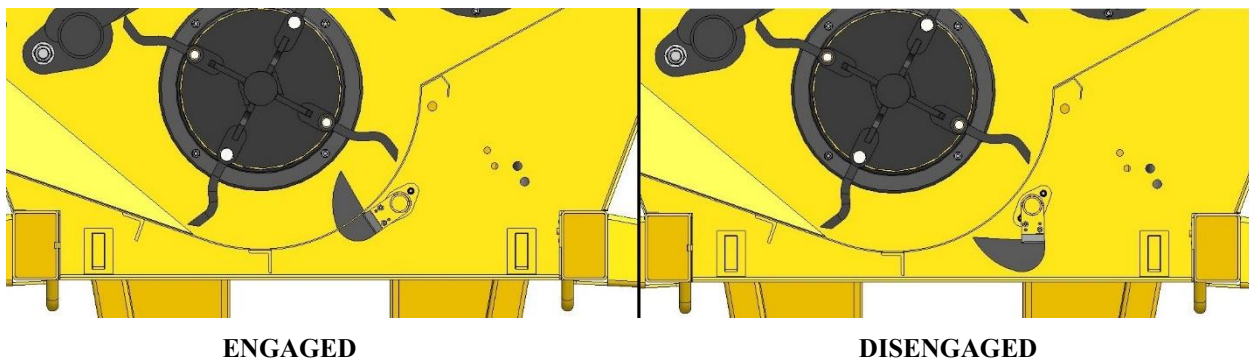

There are two settings for the fine chop, depending on how fine you wish to cut the material. These settings can be achieved by pulling out the handle, then selecting the desired hole.

0	Disengaged
1	Partially Engaged
2	Fully Engaged

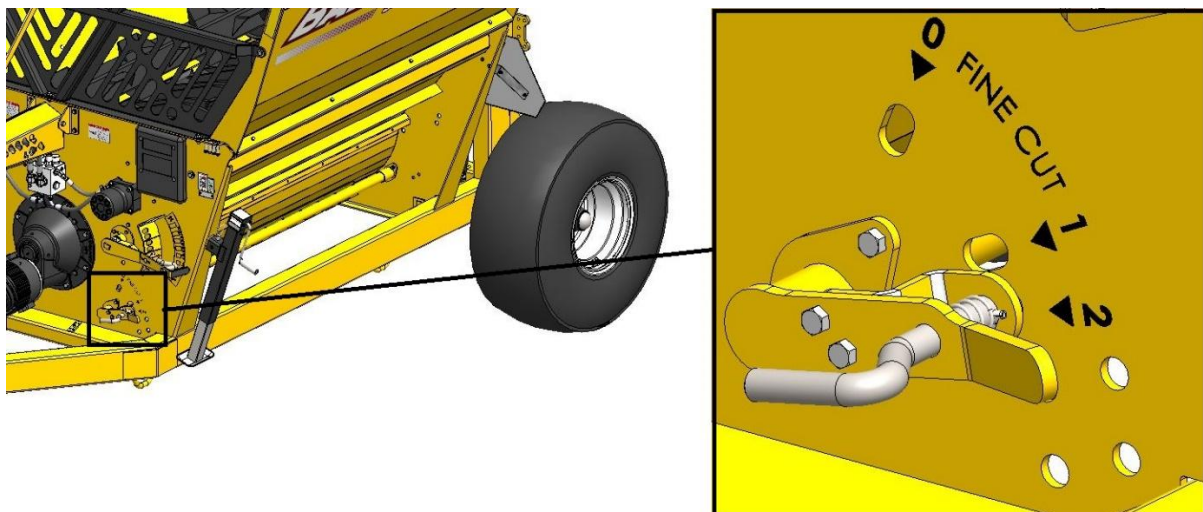

Optional Back-up Camera

The Bale King 5325 processor has an optional back-up camera to provide increased visibility while loading bales. This is especially helpful when combined with a 3-bale kit.



There are two versions of the kit.

Standard Kit	Pro Kit
33879	33880
Camera Rated to -20°C (-4°F)	Camera Rated to -40°C (-40°F)

The kit includes a mounting bracket to install the camera on the rear axle of the processor, as well as cables to run to the tractor. The monitor can be installed in the tractor cab, with a plug between the tractor and processor.

SERVICE AND MAINTENANCE

Greasing Locations

Lubricating the Bale King bale processor should be done on a regular basis.

Every 50 bales			
A	Rotor Gearbox	1	3-5 pumps
Every 150 bales			
B	Bale Fork Pivot	2	3-5 pumps
C	Gearbox Spline	1	3-5 pumps
D	Hoop Handle	1	3-5 pumps
E	PTO Cross & Bearings	4	5 pumps
	PTO Guard Bushings	2	5 pumps
	PTO Spline	1	8-10 pumps
Every 500 bales (or Annually)			
E	PTO CV Joint	1	30 pumps
F	Roller Bearings	2	3-5 pumps (DO NOT OVERGREASE)
G	Rotor Bearing	1	3-5 pumps (DO NOT OVERGREASE)
H	PTO Extension Bearing	1	3-5 pumps (DO NOT OVERGREASE)
I	Jack	1	8 – 10 pumps
Annually			
J	Wheel Hubs	4	Pack hubs full

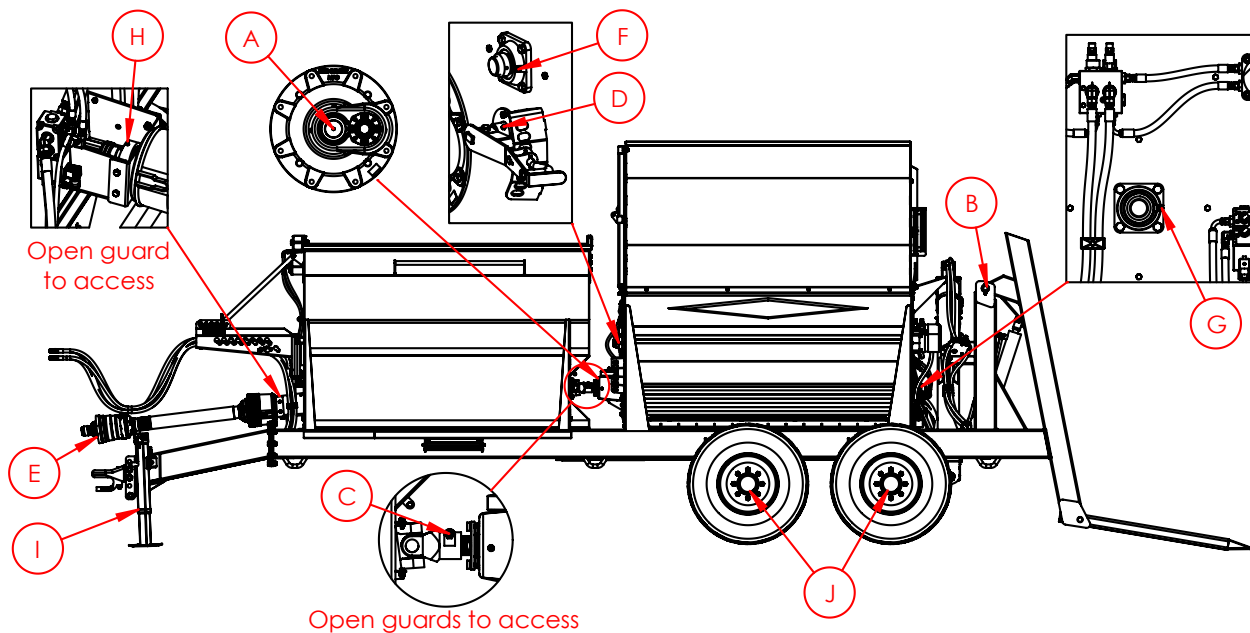

PTO/Driveline

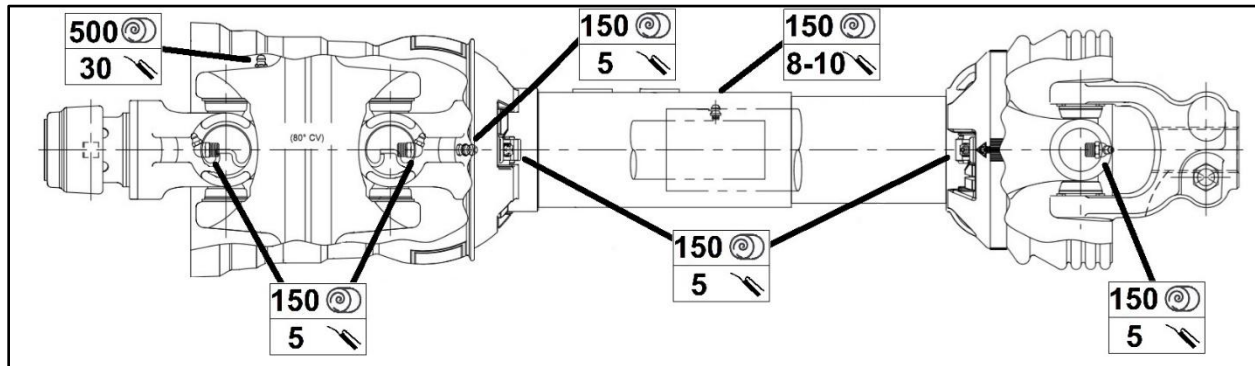

After storage for long periods of time, lubricate and check the function of every driveline component before operating. Failure to grease all the joints will **VOID** warranty.

All zerks can be accessed while the PTO is connected to the tractor EXCEPT for the telescoping spline, which can only be accessed when the PTO is fully retracted.

If operating in very cold temperatures (below -20°C or -5°F), low temperature grease (ex. EP-1 synthetic) should be used, especially where the splines overlap. This will make extending / retracting the shaft much easier and relieve stress from turning.

Gearbox

There is one grease zerk on the front of the gear box. Apply 3-5 pumps of good quality grease every 50 bales.

If the gearbox is removed to replace the rotor or perform any other service, add **80 pumps** of grease to the grease zerk upon reinstallation.

The gear box requires GL5 80W90 gear oil. The oil should be filled to the level plug (approximately **500 mL**) and checked on a regular basis. The oil should also be changed at the following intervals:

- 250 bales after first use
- Every 2000 bales afterwards, or annually (whichever comes first)

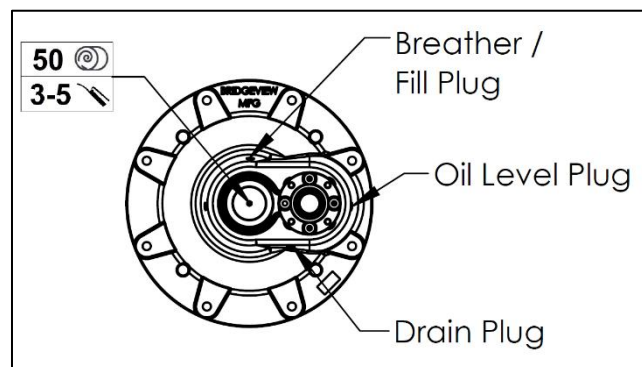

Cylinder Maintenance

The hydraulic cylinders are easily removed for repair or maintenance simply by:

- Lowering the fork (or deflector) to the down position and unhooking the hydraulic lines. Be sure there is no pressure on the lines and mark the line locations so there is no confusion when reinstalling the cylinders. Check hydraulic schematics.
- Removing the cotter pin closest to the frame of the machine and sliding the cylinder pins out
- To reinstall, reverse the removal procedure

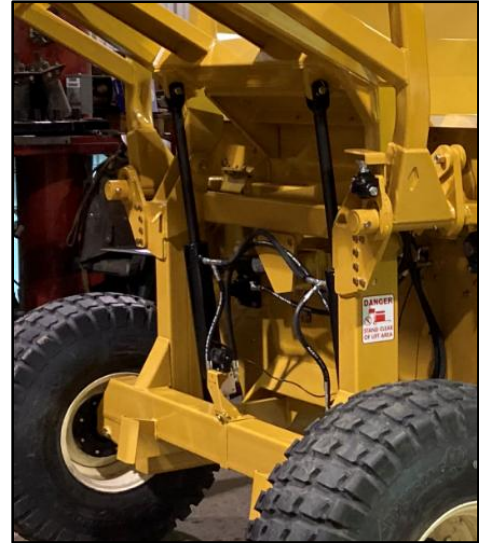

NOTE: *Always cover exposed cylinder shafts with grease to avoid rusting of shafts if the unit is not used for extended periods of time. Rusted cylinder shafts are NOT covered by warranty*

NOTE: *Check all hoses and fittings periodically for leaks. Tighten or replace any dripping components or any worn out hoses.*

Tires

Wheel bearings should be inspected annually for adjustment and lubricated annually. Inspect more often for extensive traveling.

- To tighten the wheel bearings, lift up each wheel (one at a time) until the wheel spins freely.
- Remove dust cap and the cotter pin which retains the castle nut.
- Tighten the nut until the wheel will rotate approximately two turns when given a firm spin.
- Align castle nut to closest hole and insert the cotter pin.
- Pack hub full of grease and reinstall the dust cap.

Proper tire inflation will help to alleviate puncture problems when towing and operating on rough terrain.

Check for proper tire inflation	70 psi
Replace any damaged or worn tires	12-16.5 12-ply
Check and tighten wheel bolts on a regular basis	125 ft.lb

Note: Warranty does not cover damaged rims and hubs due to loose wheel bolts or flat tires.

Tire warranty is covered by the tire manufacturer.



Note: When inflating tires, use a clip-on chuck and extension hose long enough to allow you to stand to one side and NOT in front of or over the tire assembly.

Twine Removal

It is natural that twine from the bales will wrap around the rotor as they are being processed. It is recommended to remove the twine from the rotor every 10-15 bales to avoid having so much that it begins to hinder the flail movement. The more often this is done, the easier it is to remove, since the twine has not had a chance to wrap more tightly. The patented “X” shape makes twine removal much easier.

WARNING: Before attempting the removal of twine from the rotor, be sure that the machine is stopped and the tractor is shut **OFF**. Place the tractor in park. Twines can be removed with the use of the optional knife, or any other knife.

An electric device is also available from suppliers to melt the twine & allow it to be pulled off. Once melted, the twine should be removed immediately to prevent damage to the rotor. It is **NOT PERMITTED** to leave the twine burning on the rotor as this has several adverse effects:

- It may take the temper out of the steel, rendering it weaker.
- Loose straw and hay remaining in the machine may ignite causing a fire in the processor.
- Excessive buildup of melted plastic.
- Dry out bushings causing them to wear prematurely.

NOTE: *Bridgeview Manufacturing Inc. VOIDS warranty for any damage caused by twine burning in the processor.*



Twine guards are installed on the machine to keep bale twine out of important areas such as bearings.

- The wheel hubs have a twine guard to keep anything from getting tangled in the wheel bearing. Check for and remove any twine which may have wrapped around the spindle.
- The main rotor and the rollers are equipped with removable twine guards. The guards are mounted to inside of the front and rear walls of the machine. The twine guards are bolted and need to be removed if you need to remove or tighten the bolts on the bearings or the hydraulic motors.
- Remove any twine which may have wrapped around the rollers.

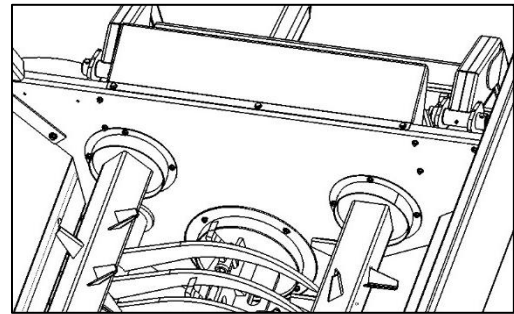

Gearbox and Flail Replacement Procedure

Flail replacement is accomplished by removing the 3/4" x 4-3/4" bolt holding the flail to the rotor. The flail is then lifted away from the rotor. The bushing can now be removed by using slight pressure to push it out of the flail. Inspect the bolt, bushing, and the flail for wear. If wear is excessive, replace with new parts.

Bridgeview Manufacturing Inc. recommends when changing flails to change in **PAIRS** (opposite each other). Processing bales with broken flails causes the rotor to be out of balance and excessive vibration may cause machine deterioration.

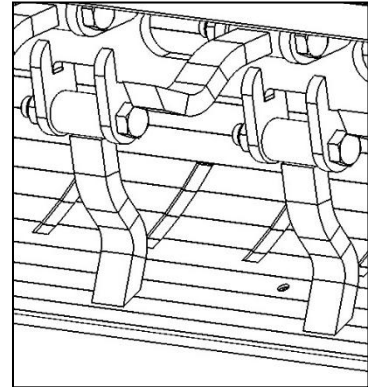

If a new rotor is required, care must be taken when reinstalling:

- Clean the spline and shaft ends of the rotor of any debris
- Clean the inside of the gearbox. Check the splines for damage.
- Slide rear twine guard over the rotor
- Install new rotor bearing (if necessary). Torque to **200 ft-lb**
- Slide the rotor through the rear bearing. Do not tighten collar yet
- Install the gearbox over the rotor spline and bolt to the tub
- Check flail clearance of **1/2 to 5/8"** to tub panel
- Center the rotor in the tub so that the flails are centered between the hoops and slots
- Tighten bearing lock collar **counter-clockwise**. Apply *loc-tite* to the set screw and torque to **100 in-lb**.
- Check gearbox oil to the side plug level (~500 mL). Replace if necessary.
- Add **80 pumps** of grease to the front gearbox grease zerck.
- Install rear twine guard using 3/8" bolts.

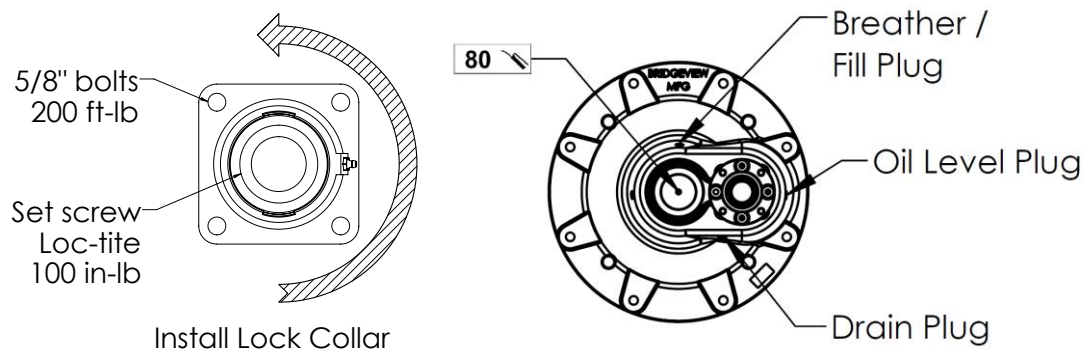

Trouble-shooting Guide

Problem	Possible Cause	Remedy
Excessive vibration while processing bales	Overloading rotor	<ul style="list-style-type: none"> • Set hoops to less aggressive position • Slow rotation of bale • Change direction of bale rotation (counter clockwise as much as possible)
	Operating machine at less than 1000 PTO RPM	<ul style="list-style-type: none"> • Operate machine at rated 1000 PTO RPM
	Broken flails causing rotor to be out of balance	<ul style="list-style-type: none"> • Replace broken flails (in pairs opposite each other)
	Excessive twine wrapped on rotor causing flail movement to be restricted	<ul style="list-style-type: none"> • Cut twine off rotor
	Rotor bearing failure	<ul style="list-style-type: none"> • Replace failed parts
Excessive shear bolt breakage	High machine vibration	<ul style="list-style-type: none"> • See above
	Engaging PTO at high engine speed or too quickly	<ul style="list-style-type: none"> • Idle tractor to engage PTO then bring up to full operating speed • Feather PTO lever into position
	Excessive horsepower	<ul style="list-style-type: none"> • Use smaller tractor (Max 150 HP)
	Incorrect shear bolt used	<ul style="list-style-type: none"> • Use correct shear bolt
Bale not turning	Excessive loose material in tub causing roller to jam	<ul style="list-style-type: none"> • Reverse direction of bale rotation to clean out • Turn bale more slowly
	Rotary straw bale bridging across rollers	<ul style="list-style-type: none"> • Install rotary straw assist kit
	Second bale interfering	<ul style="list-style-type: none"> • Lower fork slightly
	Tractor relief pressure set too low	<ul style="list-style-type: none"> • Set tractor relief pressure to at least 2500 PSI
A single roller stopping	Mechanical flow divider valve not functioning correctly	<ul style="list-style-type: none"> • Contact your dealer for repairs
	Coupler between motor and roller broken	<ul style="list-style-type: none"> • Replace failed parts
No grain Flow (Total Ration only)	Flow control valve set too low	<ul style="list-style-type: none"> • Increase flow rate in tractor or on flow control valve
	Flow control valve relief pressure set too low	<ul style="list-style-type: none"> • Use hydraulic pressure gauge to ensure relief pressure is set to 2200psi. • Ensure sufficient pressure from tractor
	Auger chute at too shallow of an angle for grain to clear fast enough	<ul style="list-style-type: none"> • Run auger slower • Run chute at steeper angle
Fork not Lifting	Lifting on the 3 bale arms trips a shutoff valve	<ul style="list-style-type: none"> • Lower fork slightly. Open 3 Bale Kit fully before lifting into tub

Features and Specifications

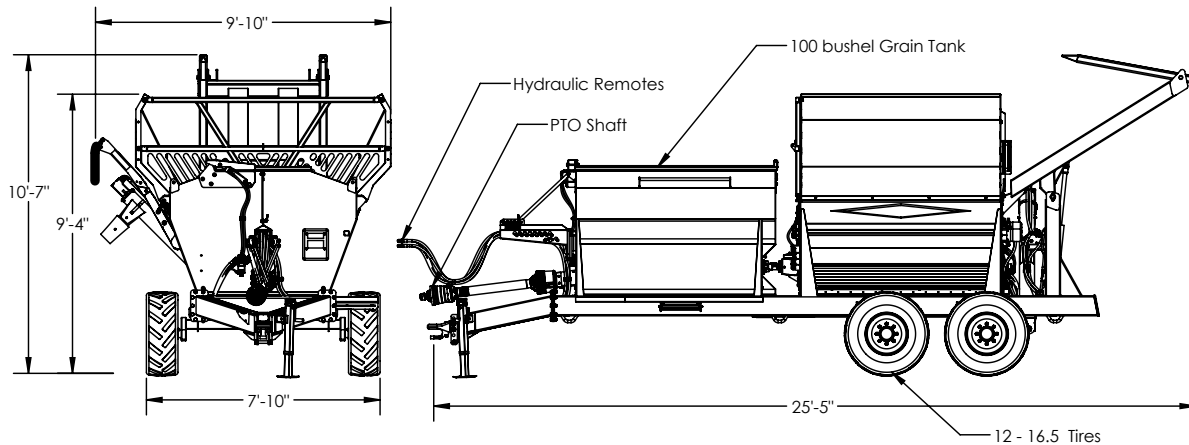

Dimensions:

Overall Weight	7850 lb
Drawbar Weight	950 lb
Overall Length (Forks Down)	27'-9"
Overall Width (Deflector Down)	
Grain Tank Capacity	100 bushels
Grain Tank Opening	32 x 76 in
Rotor Extended Tip Diameter	27 in.
Discharge Opening	12 x 80 in.

Wheels:

Tire Size	12 - 16.5 12-ply
Tire Inflation	70 psi
Wheel Nut Torque	125 ft-lb

Driveline:

Minimum Horsepower	100 HP
	*Ensure sufficient horsepower for terrain driven.
PTO Shaft	Weasler: Cat. 6 80 deg. C.V. 1-3/4"-20 Standard 1-3/8"-21 Optional
Shear Bolt	3/8 x 2" Fine Thread Gr. 5
Rated PTO RPM	1000 RPM
Flail Tip Speed at 1000 RPM	7000 FPM
Number of Flails	28
Flail Size	3/4 x 1-1/2 x 7 in.
Flail Bushing	Oil Impregnated Brass
Rotor Shaft	1-15/16" Bearing
Gearbox Oil	GL5 80W90
Gearbox Oil Capacity	500 mL

Hydraulics:

Required Remotes	3
Minimum Flow Requirements	15 GPM
Minimum Pressure Requirements	1800 psi

Other:

Roller Shaft	1-3/4" Bearings
Twine Guards	Rotor, Rollers, Axles
Adjustable Bale Fork Width (on centers)	48 in. or 40.5 in.
Adjustable Hitch Height	3 settings at 2.25 in. intervals (13" -17.5")
Discharge deflector	Adjustable top and bottom Removable rubber end flap

PARTS MANUAL

Machine Overview	36
Jack & Hitch	37
Axles & Wheels	38
Spindle	39
Rotor & Drive Components	40
Drive Shaft	41
Gearbox	42
PTO Shaft.....	44
Grates	45
Rollers	47
Top Tub Components	48
Rear Tub Components	49
Slow Moving Vehicle (SMV) Sign Kit	51
Lights & Harness	52
Rear Forks.....	53
Deflector & Hose Cover	54
Main Frame Components.....	56
Grain Tank	57
Grain Tank Lid.....	59
Bottom Auger.....	60
Cross Auger	61
Hose Holder and Manual Holder	63
Decals.....	64
Fine Chop Option #36155.....	68
Fine Chop Option #32117.....	70
Twine Cutter Option	71
Back-up Camera Option	72
Diverter Control Box	73
Hydraulic Schematics	76
HYDRAULIC FITTINGS	76
HYDRAULIC HOSES	77
NOTES.....	81

Machine Overview

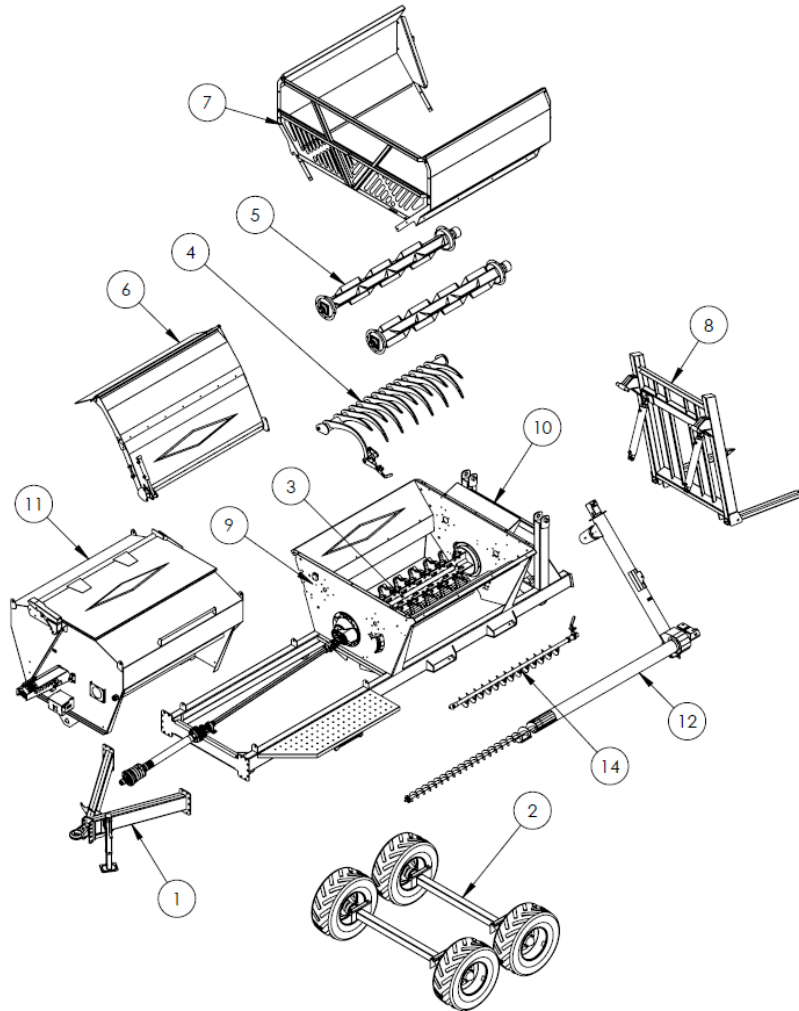

1	Jack & Hitch	Page 37	9	Main Frame Components	Page 56
2	Axle & Wheels	Page 38	10	Rear Tub Components	Page 49
3	Rotor & Drive Components	Page 40	11	Grain Tank	Page 57
4	Grates	Page 45	12	Grain Auger Components	Page 60
5	Rollers	Page 47	13	Decals	Page 64
6	Deflector & Hose Cover	Page 54	14	Fine Chop Option	Page 68
7	Top Tub Components	Page 48	15	Diverter Control Box	Page 73
8	Rear Forks	Page 53	16	Hydraulic Schematics	Page 76

**** CHECK YOUR SERIAL NUMBER BEFORE ORDERING PARTS ****
**** PAY ATTENTION TO SERIAL NUMBER SPLITS WHERE INDICATED ****
**** LEFT / RIGHT AS DESCRIBED ARE VIEWED FROM THE REAR ****

Per Quantities: A/R = As Required
 Per ID#: NSS = Not Sold Separately

Jack & Hitch

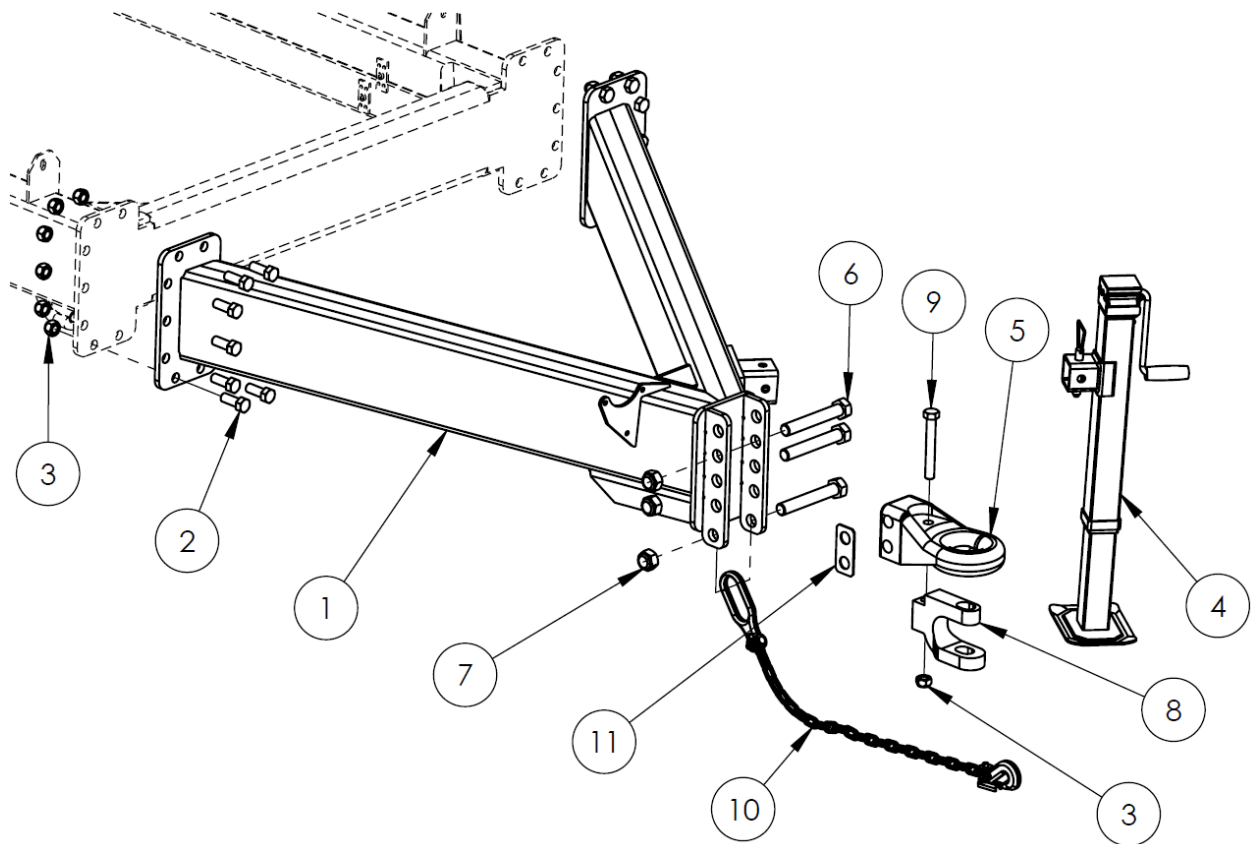

#	DESCRIPTION	PART #	QTY	
1	Hitch Frame	35828	1	
2	Bolt, 3/4 x 2"	13800	14	
3	Nut, 3/4" Stover Lock	11823	14	
4	Jack, 7000 lb	Comes with pin	35250	1
5	Hitch Tongue	23404	1	
6	Bolt, 1" x 6-1/2"	28426	3	
7	Nut, 1" Stover Lock	21746	3	
8	Hitch Clevis Kit	Includes 9 & 3	25540	1
9	Bolt, 3/4 x 5-1/2"	26406	1	
10	Safety Chain, 21000lb x 52"	23559	1	
11	Hitch Shim	10 gauge 12 gauge 14 gauge 16 gauge	35926 35927 35928 35929	A/R

Axles & Wheels

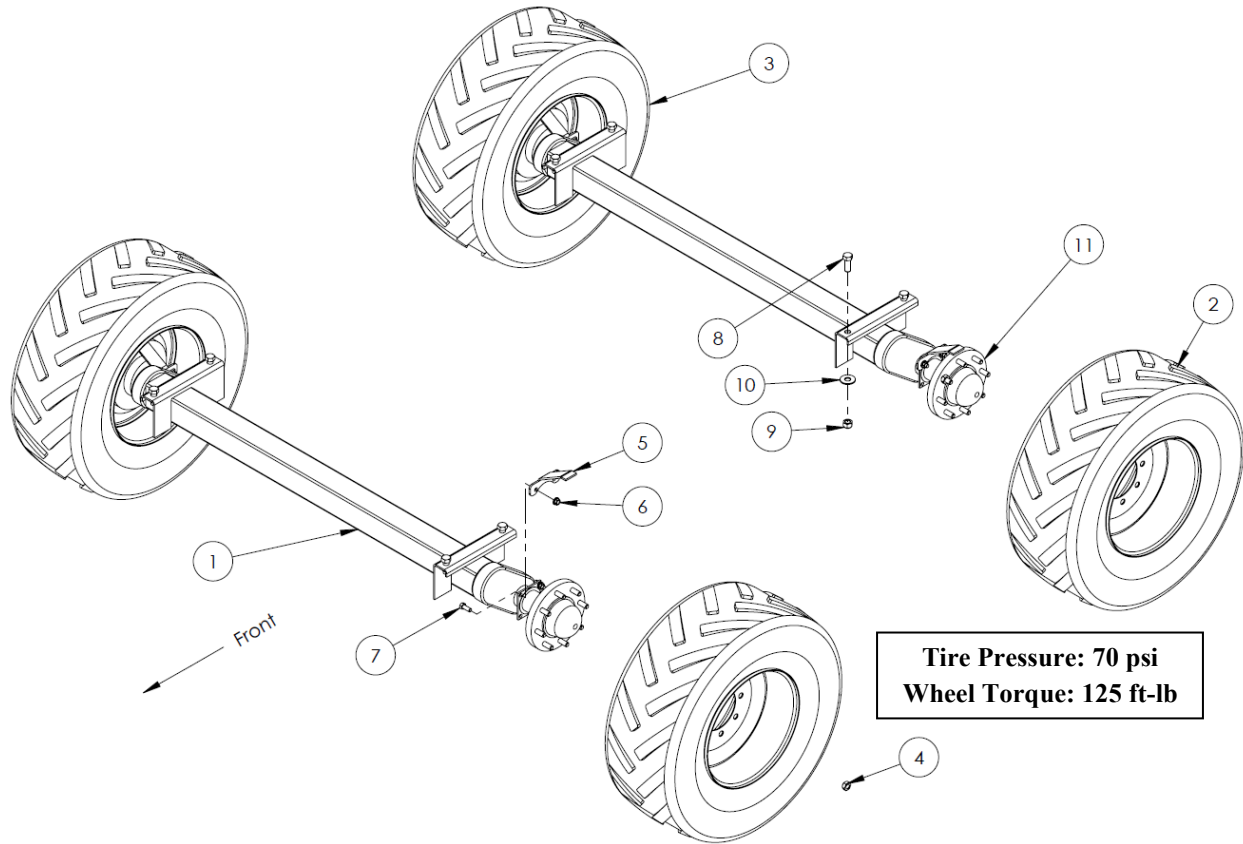

#	DESCRIPTION	PART #	QTY
1	Torflex Axle	27411	2
2	12-16.5 NHS Tire and Wheel Assembly - Left	27432	2
3	12-16.5 NHS Tire and Wheel Assembly - Right	27431	2
4	5/8" Lug Nut	23183	32
5	Twine Guard	23414	4
6	Nut, 1/2" Serrated Flange	10273	8
7	Bolt, 1/2" x 1-1/4"	10240	8
8	Bolt, 3/4" x 2"	13800	8
9	Nut, 3/4" Stover Lock	11823	8
10	Flat Washer, 3/4"	13717	8
11	Hub Assembly	See breakdown pg. 39	4

Spindle

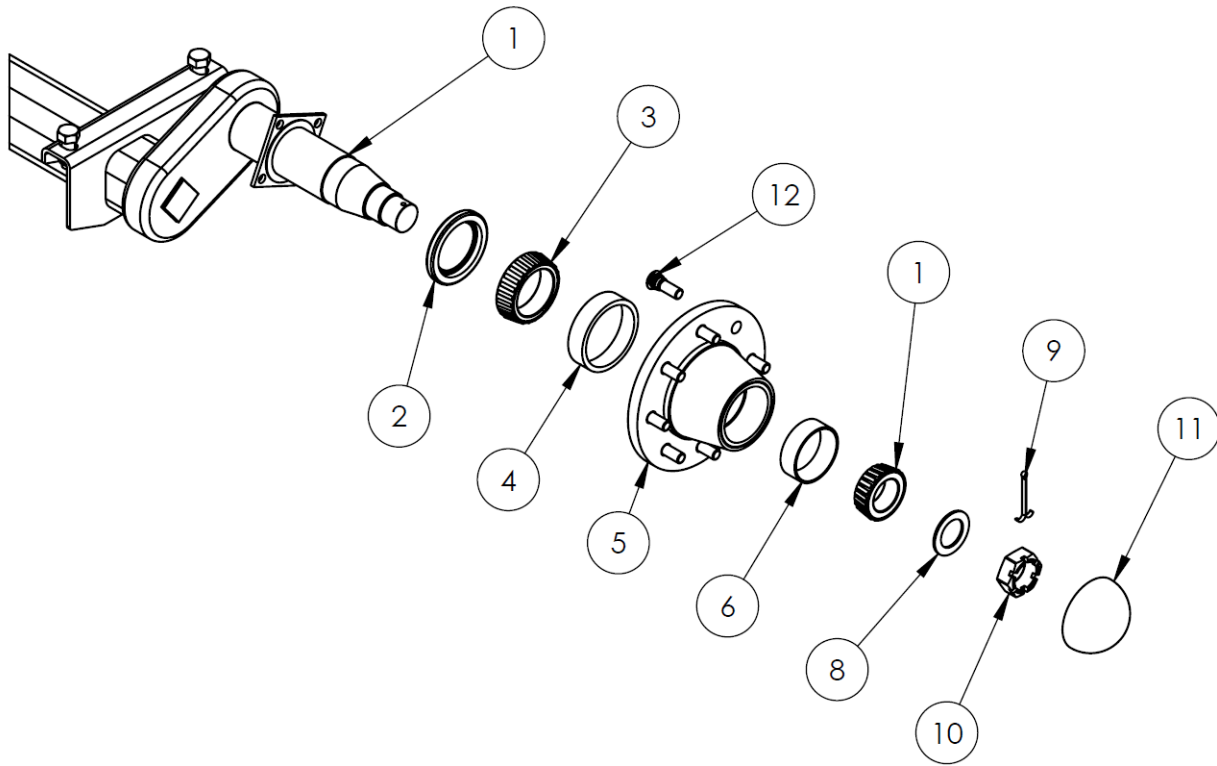

#	DESCRIPTION	PART #	QTY	
1	Complete Torflex Axle Assembly	27411	1	
2	Seal	23569	1	
3	Inner Bearing	JLM506849	23567	1
4	Inner Bearing Race	JLM506810	23571	1
5	Hub Housing	Includes 4,6,12	23572	1
6	Outer Bearing Race	LM501310	23570	1
7	Outer Bearing	JLM501349	23568	1
8	Spindle Washer		23564	1
9	Cotter Pin, 5/32 x 2"		23565	1
10	Castle Nut		23566	1
11	Dust Cap		23563	1
12	Grease Zerk		10270	1
12	Wheel Stud		23573	8

NOTE: Quantity is per hub

Rotor & Drive Components

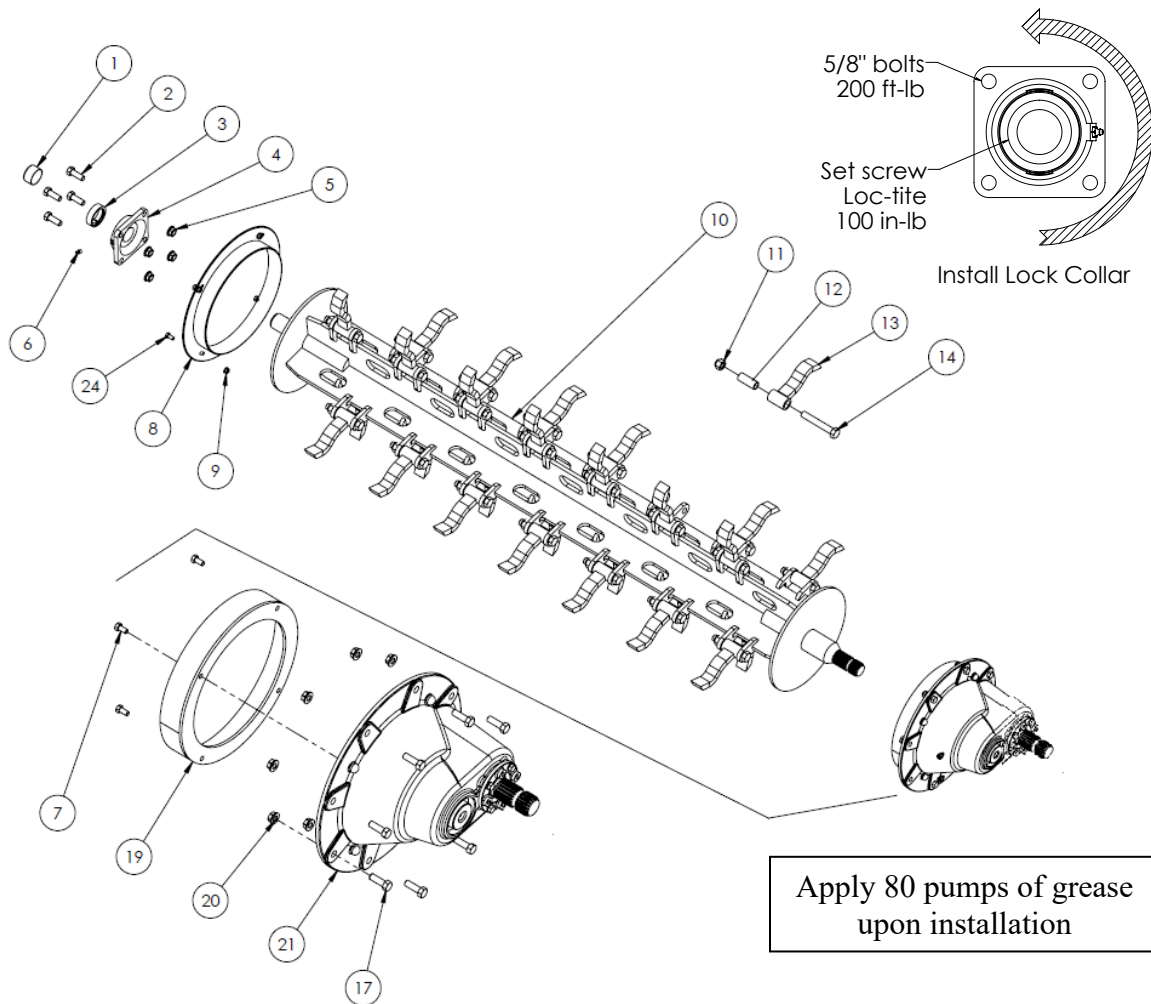

#	DESCRIPTION	PART #	QTY
1	Rotor Shaft Cap	17380	1
2	Bolt, 5/8" x 1-3/4" NF Gr. 8	10274	4
3	Lock Collar	10268	1
4	Rotor Bearing	Includes # 3 & 6 10221	1
5	Nut, 5/8" NF Serrated Flange Gr. 8	15398	4
6	Grease Zerk, 1/8" NPT Straight	10270	1
7	Bolt, 3/8" x 3/4"	11816	4
8	Rotor Twine Guard, Rear	22413	1
9	Nut, 3/8" Serrated Flange	10271	4
10	X-Rotor Weldment	22449	1
11	Nut, 3/4" Stover Lock	11823	28
12	Brass Flail Bushing	10005	28
13	Rotor Flail	Replace in pairs 22412	28
14	Bolt, 3/4" x 4-3/4"	10443	28
17	Bolt, 1/2" x 1-1/2"	10174	8
19	Gearbox Twine Guard	23002	1
20	Nut, 1/2" Stover Lock	20154	8
21	Gearbox Assembly	See Breakdown pg. 42 22158	1
24	Bolt, 3/8 x 1"	13806	4

Drive Shaft

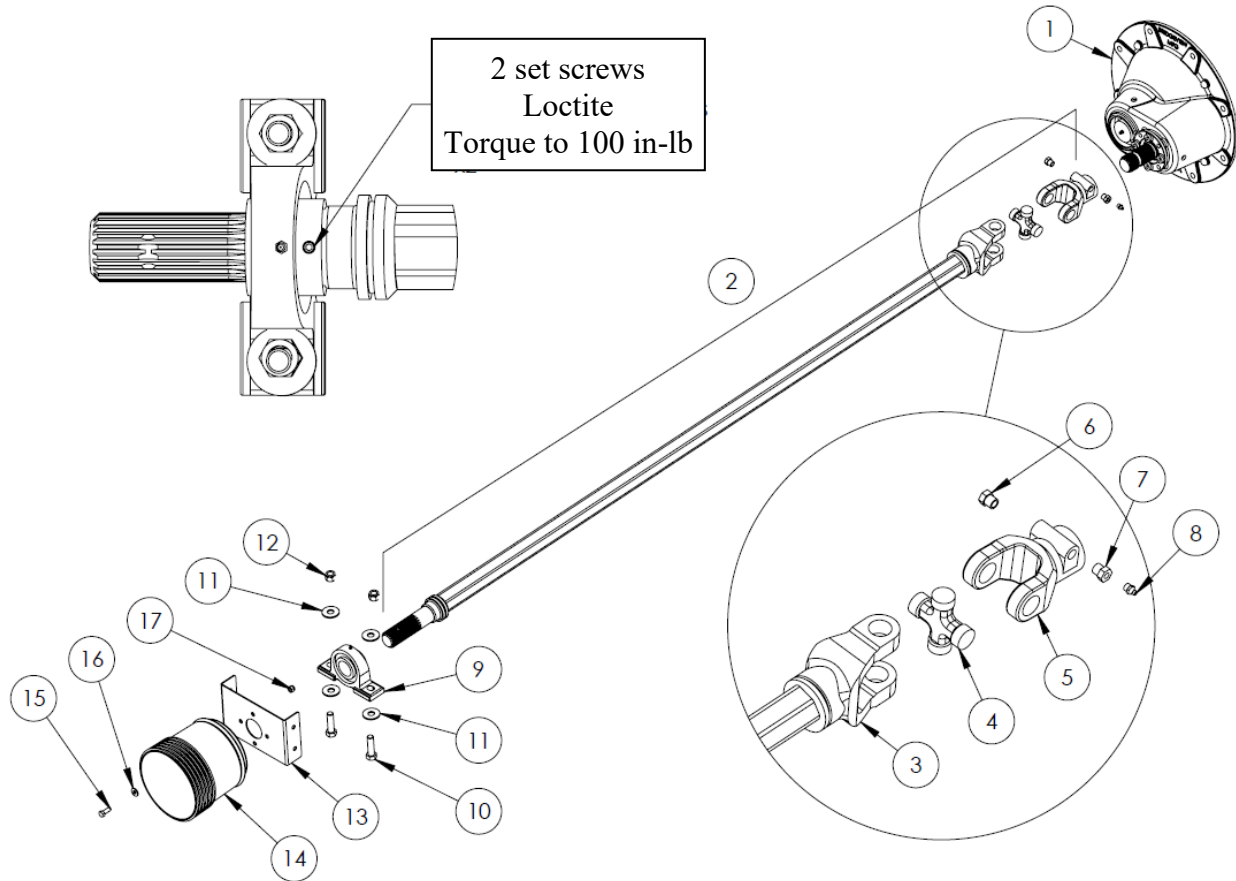

#	DESCRIPTION	PART #	QTY
1	Complete Gearbox Assembly See breakdown pg. 42	22158	1
2	Complete PTO Assembly (includes 3-8)	30437	1
3	Shaft, 20 Series	10126	1
4	Cross, 20 Series	10127	1
5	Yoke, 20 Series	24696	1
6	Brass Plug	30439	1
7	Brass Bushing	30440	1
8	Grease Zerk	10270	1
9	1-3/4" Pillow Block Bearing	30355	1
10	Bolt, 5/8" x 2-1/4"	20910	2
11	Washer, 5/8" Flat	13975	2
12	Nut, 5/8" Nylon Lock	10364	2
13	PTO Guard Bracket	30377	1
	Bolt, 3/8" x 1"	13806	4
	Nut, 3/8" Nylon Lock	10806	4
14	PTO Shield & Mount	34899	1
15	Bolt, 3/8" x 1"	13806	4
16	Washer, 3/8" Flat	11667	4
17	Nut, 3/8" Nylon Lock	10806	4

Gearbox

GL5 80W-90 Oil
~ 500 mL

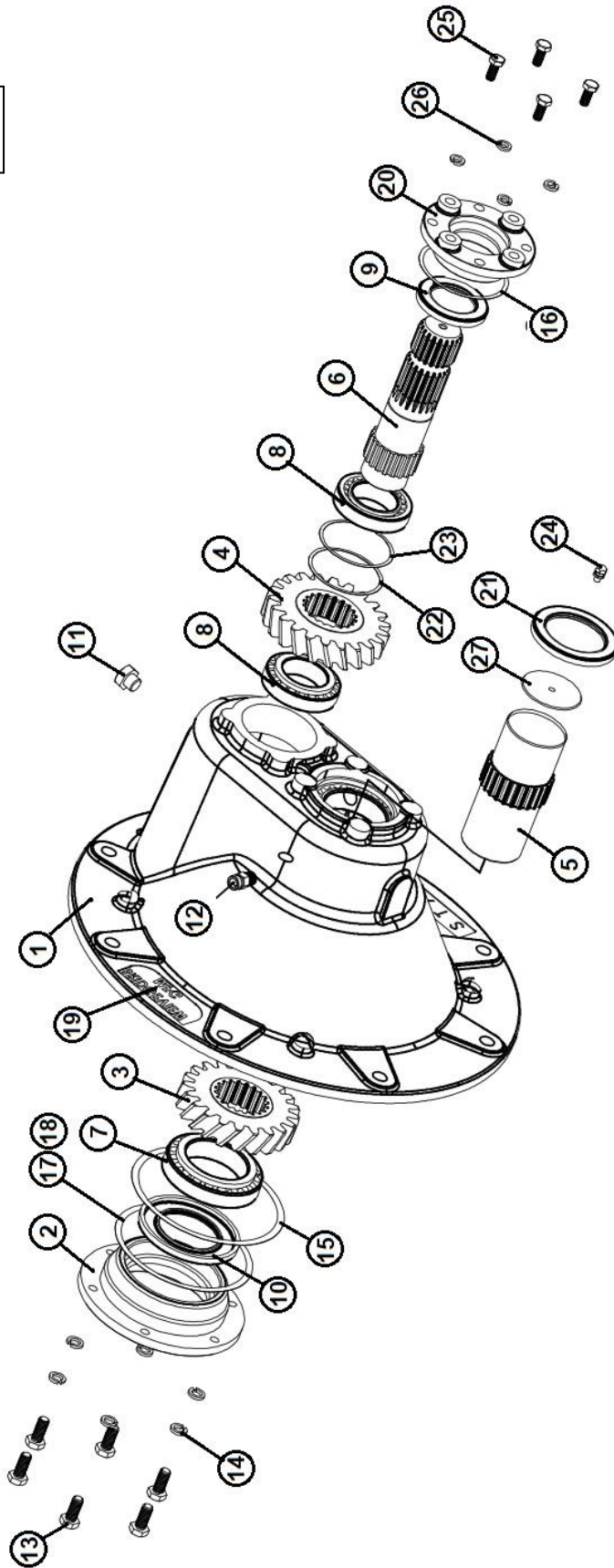

Gearbox

#	DESCRIPTION	PART #	QTY
	Complete Gearbox Assembly	22158	1
1	Housing	-	1
2	End Cap	-	1
3	Output Gear	-	1
4	Input Gear	-	1
5	Output Shaft	-	1
6	Input Shaft	-	1
7	Bearing (32012) 60mm	10496	2
8	Bearing (32009) 45mm	10497	2
9	Seal, 45 x 60 x 8	24013	1
10	Seal, 60 x 100 x 10	10498	1
11	Pipe Plug, 3/8" NPT	24014	2
12	Relief Plug, 3/8" NPT	24015	1
13	Bolt, M8 x 25 Gr. 8.8	24026	6
14	Lock Washer, M8	24016	6
15	O-Ring	24017	1
16	O-Ring	24018	1
17	Shim, 125 x 164 x 0.1	24022	2
18	Shim, 125 x 164 x 0.3	24023	2
19	Name Plate (Bridgeview)	-	1
20	End Cap	-	1
21	Seal, 60 x 85 x 10	10500	1
22	Shim, 68 x 74.5 x 0.1	24024	2
23	Shim, 68 x 74.5 x 0.3	24025	2
24	Grease Zerk, 1/4"-28 Straight	26219	1
25	Bolt, M10 x 25	15087	4
26	Lock Washer, M10	24021	4
27	Press Cup	24446	1

NOTE: Items with no part number are not sold separately. A complete gearbox is required.

PTO Shaft

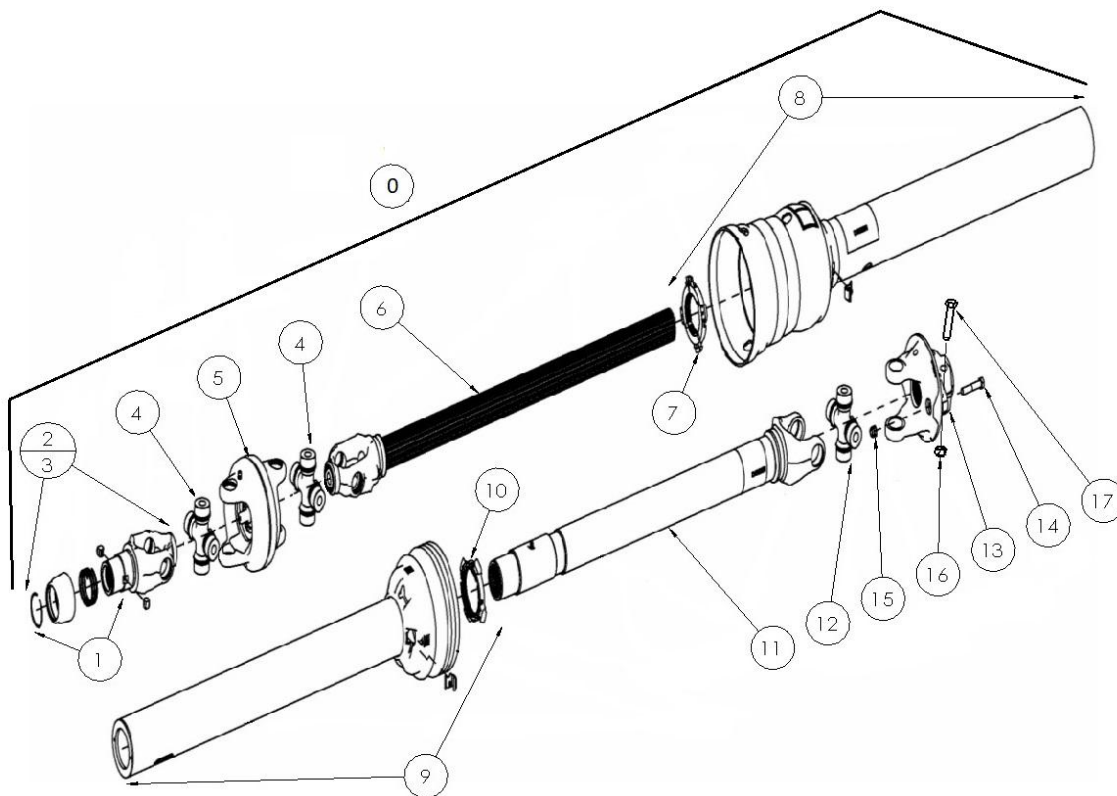

#	DESCRIPTION	PART #	QTY
	Complete PTO Shaft Assembly (1-3/8")	20546	1
0a	Tractor Half PTO Assembly (1-3/8"-21 Spline)	32505	1
0b	Tractor Half PTO Assembly (1-3/4"-20 Spline)	32506	1
1a	Safety Slide Lock Repair Kit (1-3/8"-21 Spline)	17567	1
1b	Safety Slide Lock Repair Kit (1-3/4"-20 Spline)	24981	1
2	WWCV Auto-Lok Yoke Assembly (1-3/8"-21 Spline)	20549	1
3	WWCV Auto-Lok Yoke Assembly (1-3/4"-20 Spline)	20556	
4	CV Cross and Bearing Kit (Equal Length)	20550	2
5	CV Center Housing	20551	1
6	Yoke & Shaft Assembly Tractor Side	20552	1
7	Guard Repair Kit Tractor Side	20553	1
8	Guard Assembly Tractor Side	17583	1
9	Guard Assembly Implement Side	17585	1
10	Guard Repair Kit Implement Side	17572	1
11	Yoke & Tube Assembly Implement Side	17584	1
12	U-joint Cross & Bearing Kit	17573	1
13	Shear Assembly * Does not come with bolts 14 or 17 *	29963	1
14	Shear Bolt, 3/8" x 2" Fine Thread	33285	1
15	Nut, 3/8" Fine Thread Stover Lock	33286	1
16	Nut, 5/8" Stover Lock	24982	2
17	Bolt, 5/8" x 3-1/2"	24983	2

NOTE: Ensure that the PTO shaft on the machine is correct to the drawings below. Equal length CV cross (4.19") with bearing cup diameter 1.38". If the damaged PTO has different dimensions, consult the Bridgeview Manufacturing website.

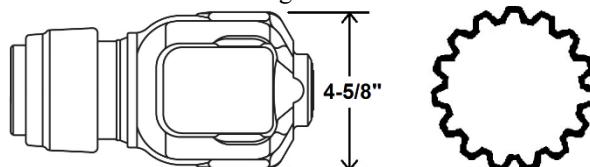

Grates

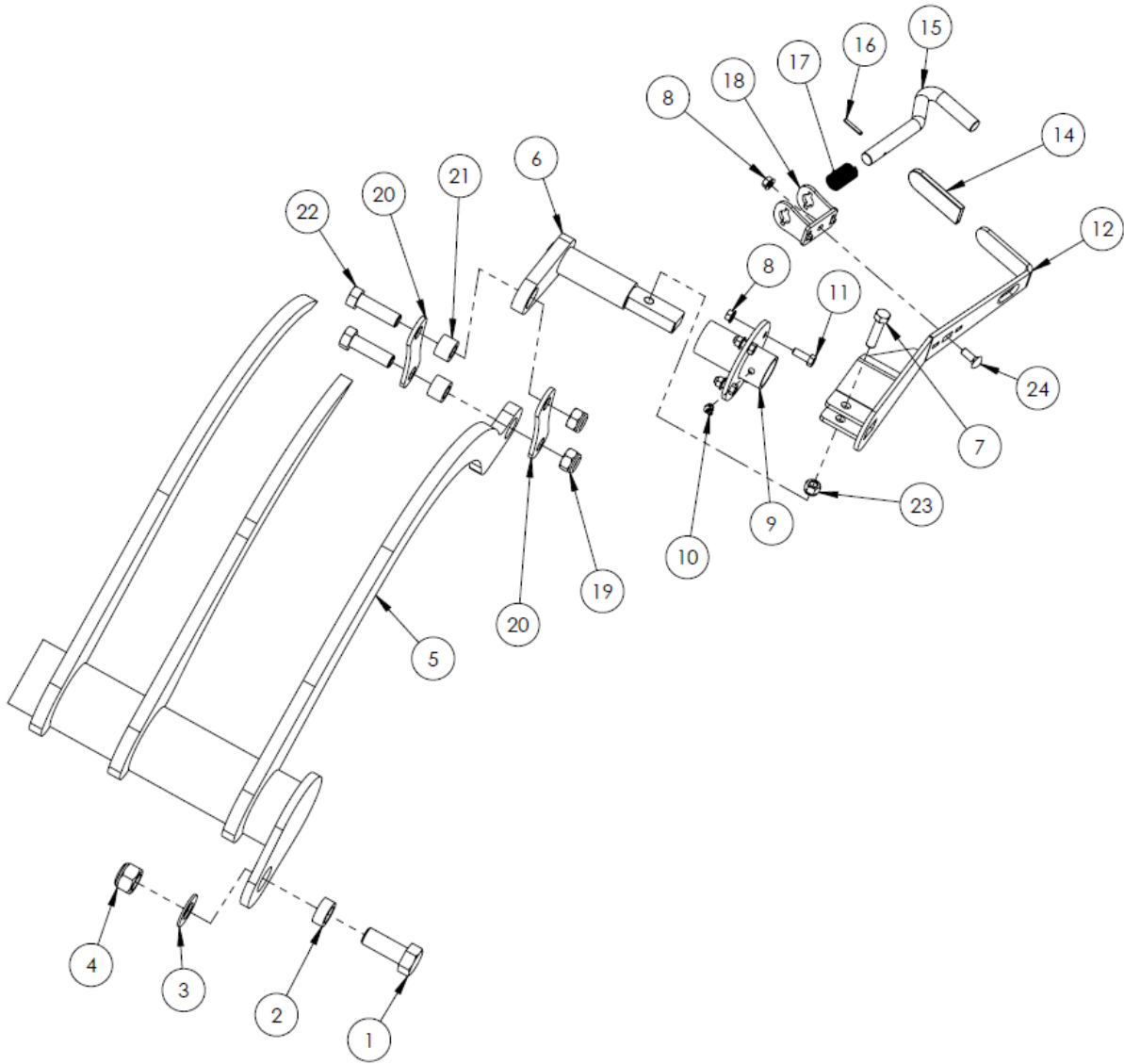

Grates

#	DESCRIPTION	PART #	QTY	
1	Bolt, 1" x 2-1/2"	21820	2	
2	Grate Pivot Bushing	22417	2	
3	Flat Washer, 1"	14472	2	
4	Nut, 1" Stover Lock	21746	2	
5	Grate Assembly	29944	1	
6	Grate Adjustment Cam	Includes #9,10	31720	1
7	Bolt, 1/2" x 2"	10322	1	
8	Nut, 3/8" Serrated Flange	10271	5	
9	Grate Handle Pivot	NSS	1	
10	Grease Zerk, 1/4"-28 x 45°	20888	1	
11	Bolt, 3/8" x 1"	13806	4	
12	Grate Handle	Comes with #18,24,8	31725	1
14	Rubber Cover	10297	1	
15	S-Handle	22187	1	
16	Roll Pin, 3/16" x 1-1/4"	10302	1	
17	Grate Handle Spring	10301	1	
18	Handle Spring Guide	33693	1	
19	Nut, 3/4" Stover Lock	11823	2	
20	Grate Shackle	31709	2	
21	Grate Shackle Bushing	22415	2	
22	Bolt, 3/4" x 2-1/4"	29824	2	
23	Nut, 1/2" Nylon Lock	10241	1	
24	Bolt, 3/8 x 1" Carriage	15718	1	

Rollers

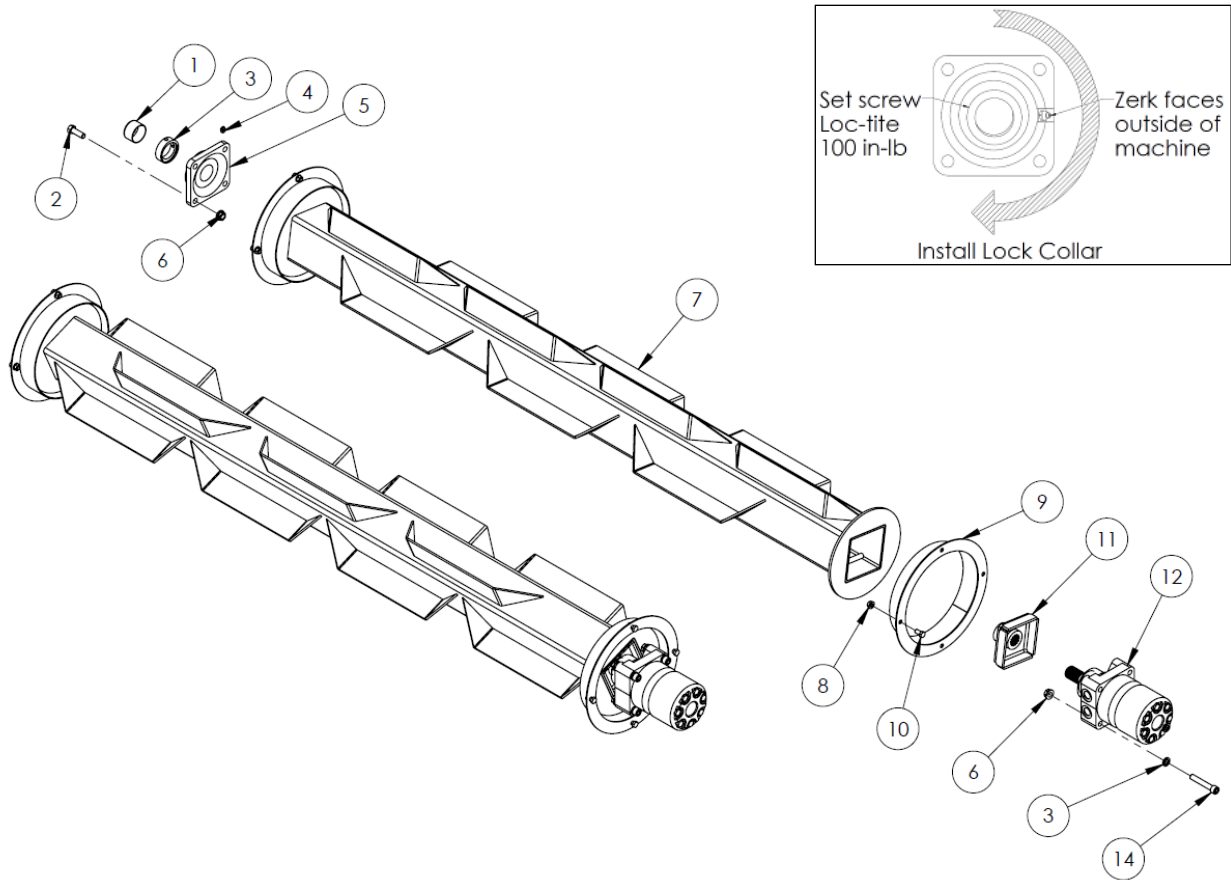

#	DESCRIPTION	PART #	QTY
1	Roller Shaft Cap	17381	2
2	Bolt, 1/2" x 1-1/2"	10174	8
3	Lock Collar	10040	2
4	Grease Zerk, 1/8" NPT Straight	10270	2
5	Roller Bearing	Includes # 3 & 4 10038	2
6	Nut, 1/2" Serrated Flange	10273	16
7	Roller	31596	2
8	Nut, 3/8" Serrated Flange	10271	16
9	Roller Twine Guard	22419	4
10	Bolt, 3/8" x 3/4"	11816	16
11	Roller Insert	22084	2
12	Roller Motor, 8" Long * Seal Kit	25872 25891	2
13	Lock Washer, 1/2"	14447	8
14	Socket Head Bolt, 1/2" x 3"	25952	8

Top Tub Components

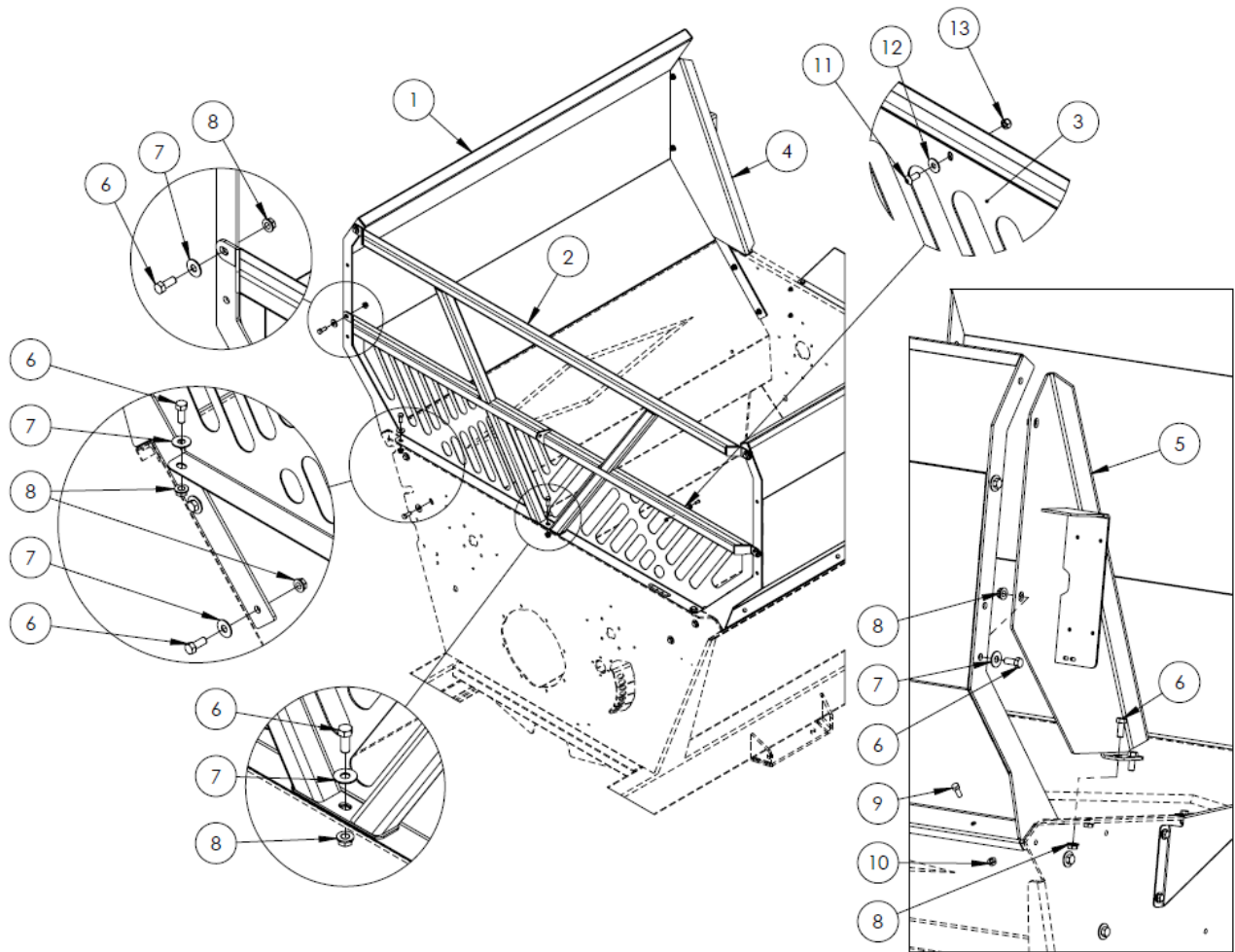

#	DESCRIPTION	PART #	QTY
1	Wing	31692	2
2	Front Rack	31730	1
3	Front Rack Grating	32479	1
4	Light Bracket RH	35833	1
5	Light Bracket LH	35835	1
6	Bolt, 1/2" x 1 1/4"	10240	23
7	Flat Washer, 1/2"	11668	19
8	Nut, 1/2" Serrated Flange	10273	23
9	Bolt, 3/8 x 1"	13806	8
10	Nut, 3/8" Serrated Flange	10271	8
11	Bolt, 5/16" x 3/4" Button Head	32513	8
12	Washer, 5/16" Flat	12496	8
13	Nut, 5/16" Nylon Lock	11815	8

Rear Tub Components

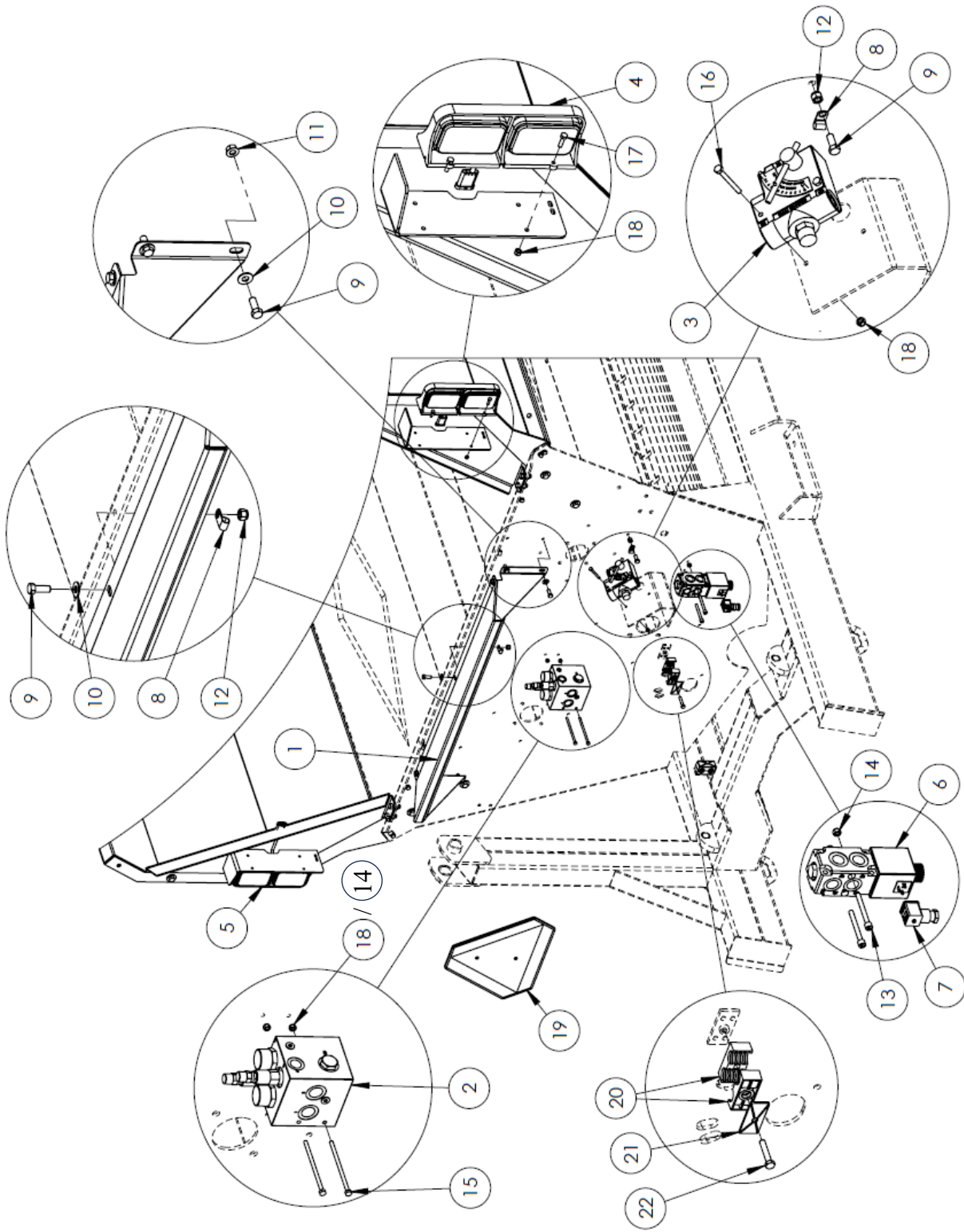

Rear Tub Components

#	DESCRIPTION	PART #	QTY
1	Rear Cover Panel	22437	1
2	Flow Divider Combiner Valve	25778	1
3	Flow Control Valve	10455	1
4	LED Light Assembly, Right	31088	1
5	LED Light Assembly, Left	31087	1
6	Diverter Valve * Nut & O-Ring Kit * Magnet Kit	11743 17977 11789	1
7	Diverter Valve Plug	13657	
8	Wiring Clamp	13629	8
9	Bolt, 3/8" x 1"	13806	12
10	Flat Washer, 3/8"	11667	7
11	Nut, 3/8" Serrated Flange	10271	4
12	Nut, 3/8" Nylon Lock	10806	8
13	Bolt, 5/16 x 3" Socket Head	11783	2
14	Nut, 5/16" Nylon Lock	11815	2
15	Bolt, 5/16 x 5" S/N BK7695 & above Bolt, 1/4" x 5" S/N BK7694 & below	36321 25951	3 2
16	Bolt, 1/4 x 2-1/2"	11811	2
17	Bolt, 1/4 x 1"	11810	8
18	Nut, 1/4" Nylon Lock	11664	12
19	Slow Moving Vehicle Sign Kit See breakdown pg. 51	22411	1
20	Hose Clamp Plastic Block	21561	2
21	Hose Clamp Cap	21725	1
22	Bolt, 5/16 x 1-3/4"	21726	1

Slow Moving Vehicle (SMV) Sign Kit

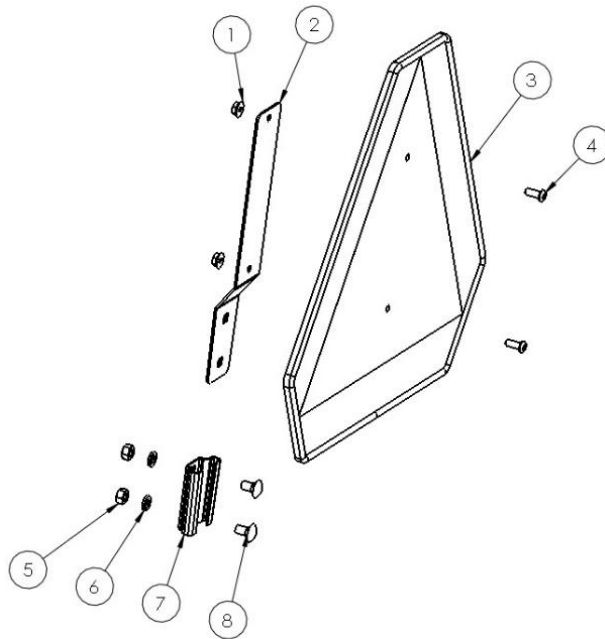

NOTE: Only the parts shown above are used on the Bale King 5325. Additional parts are included in the SMV sign kit which are not required.

#	DESCRIPTION	PART #	QTY
	Complete SMV Sign Kit	22411	1
1	Nut, 1/4" Nylon Lock	11664	2
2	Galvanized Sign Bracket	-	1
3	Plastic SMV Sign	-	1
4	Pan Head Bolt, 1/4" x 5/8"	-	2
5	Nut, 5/16"	-	2
6	Lock Washer, 5/16"	-	2
7	Galvanized Tapered Receiver Bracket	-	1
8	Carriage Bolt, 5/16" x 1/2"	-	2
9	Carriage Bolt, 5/16" x 2"	-	-
10	Lock Washer, 1/4"	-	-

Lights & Harness

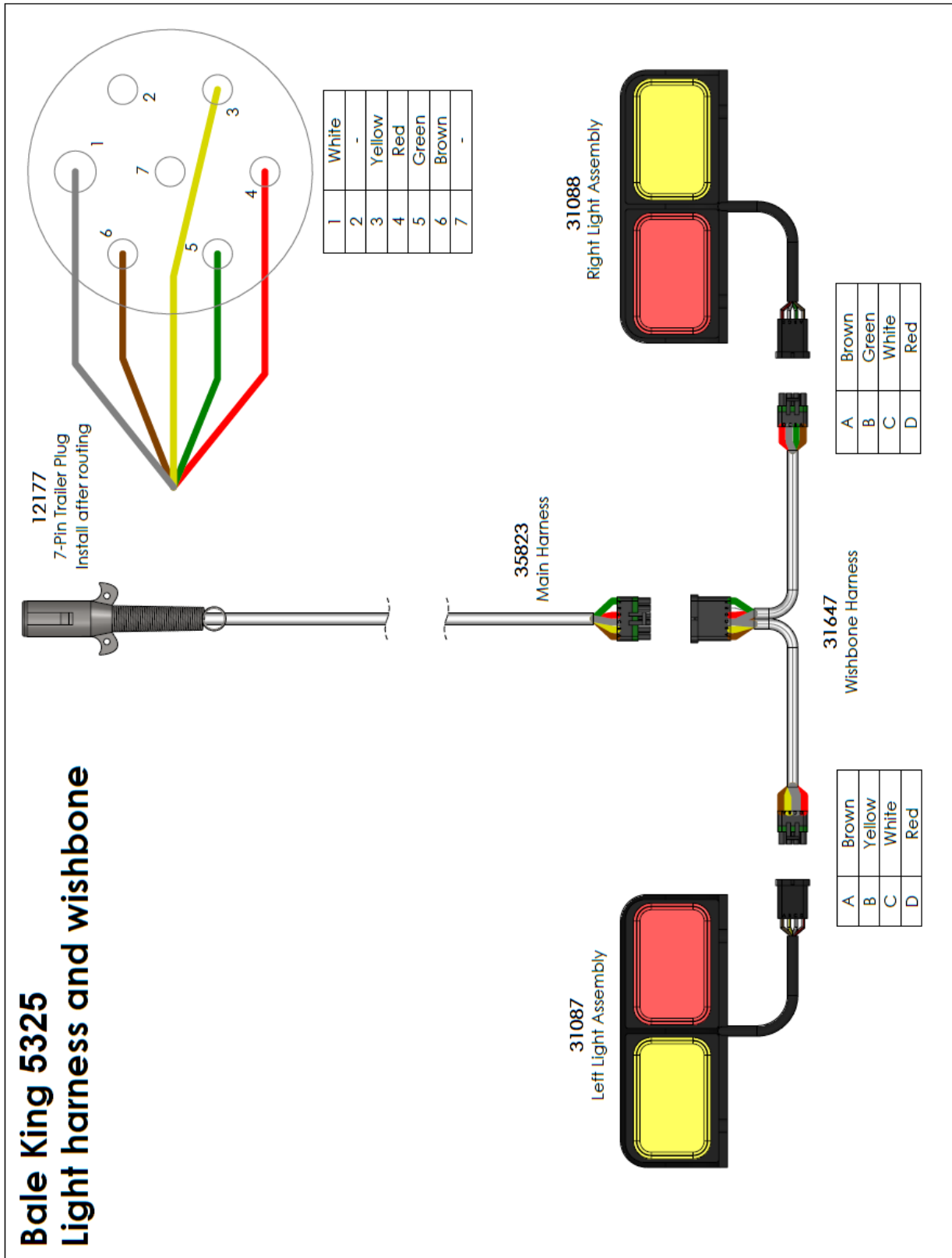

Rear Forks

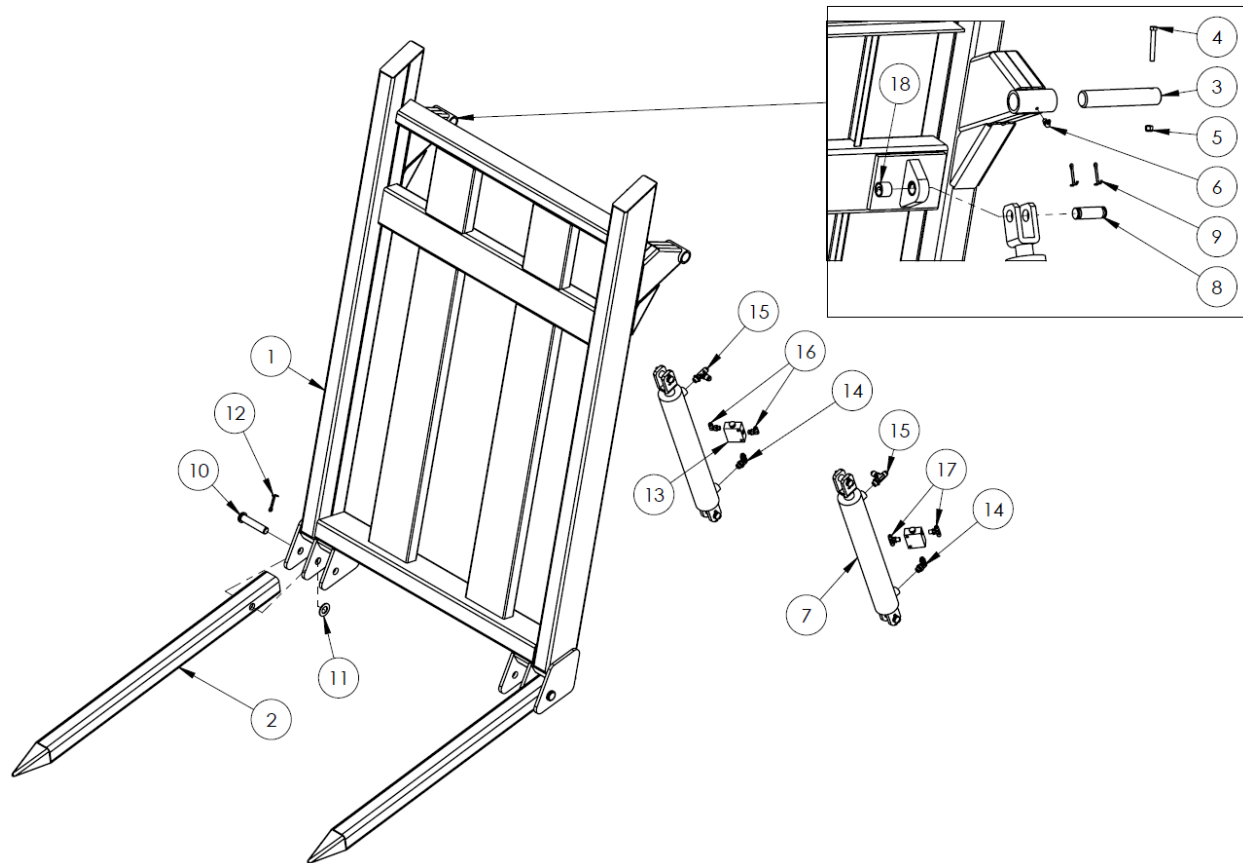

#	DESCRIPTION	PART #	QTY
1	Rear Fork Frame Includes bushing 18	30366	1
2	Fork Tine, 53" Fork Tine, 48" S/N BK7695 & above S/N BK7694 & below	36150 22421	2
3	Rear Fork Pivot Pin	22006	2
4	Bolt, 3/8" x 2-3/4"	20908	2
5	Nut, 3/8" Nylon Lock	10806	2
6	Grease Zerk, 1/4" x 90°	16389	2
7	Hydraulic Cylinder, 3" x 20" x 1-1/2" * Seal Kit	17444 17611	2
8	Cylinder Pin, 1 x 3-1/2"	10339	4
9	Cotter Pin, 3/16" x 1-1/2"	10072	8
10	Fork Tine Pin	10031	2
11	Flat Washer, 1"	14472	2
12	Cotter Pin, 1/4" x 2"	10580	2
13	Hydraulic Check Valve	19114	2
14	Hyd. Fitting, 8MB - 6MB90	33739	2
15	Hyd. Fitting, 8MBR - 8MJT	22159	2
16	Hyd. Fitting, 6MB - 6MJ90	10201	2
17	Hyd. Fitting, 6MBL - 6MJT	27678	1
18	Bushing Insert, 1"	23708	4

Deflector & Hose Cover

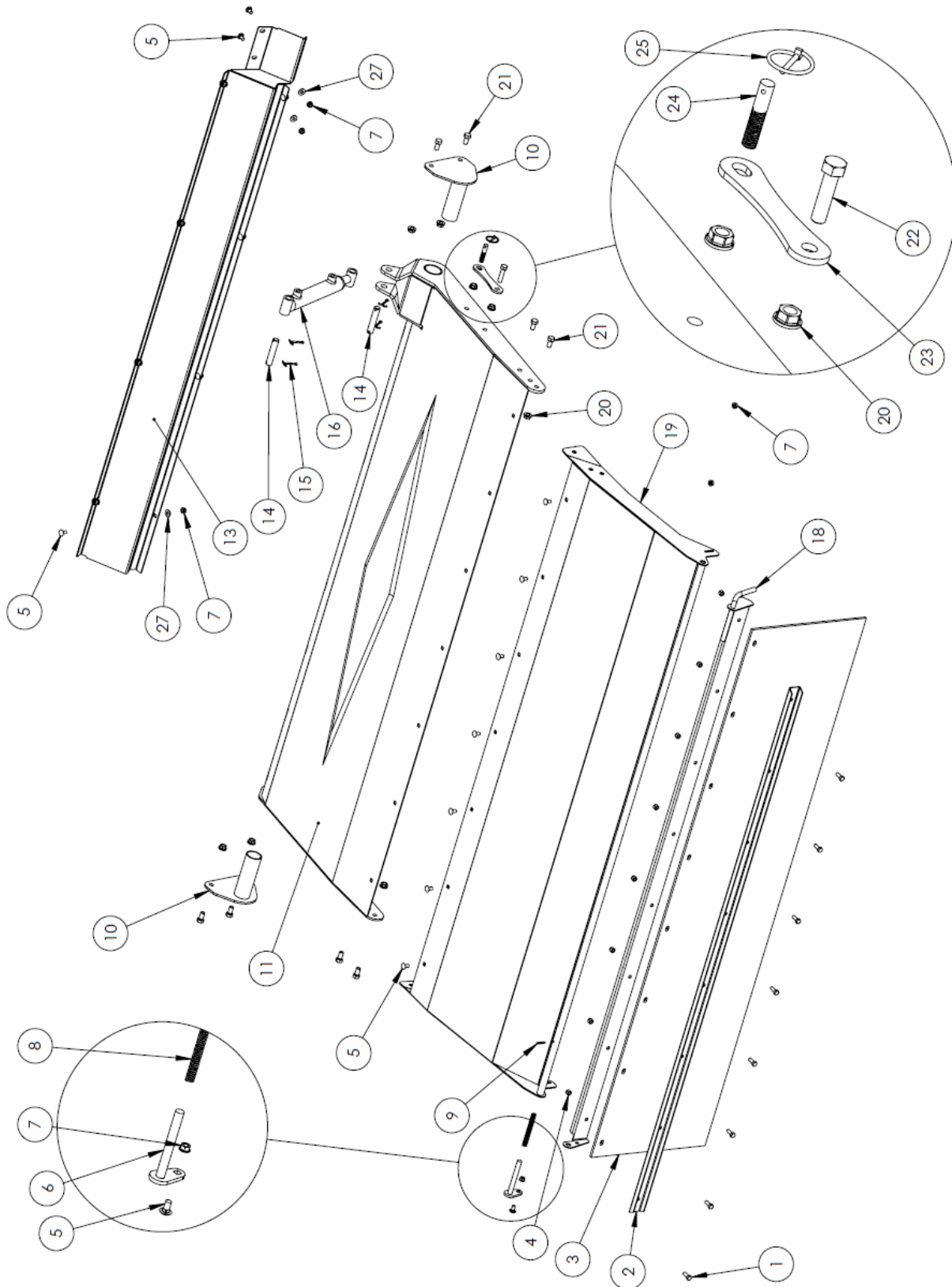

#	DESCRIPTION	PART #	QTY
1	Bolt, 3/8" x 1"	13806	8
2	Deflector Rubber Channel	22423	1
3	Deflector Rubber	10477	1
4	Nut, 3/8" Nylon Lock	10806	8
5	Carriage Bolt, 3/8" x 3/4"	14072	18
6	Deflector Flipper Pin	24464	1
7	Nut, 3/8" Serrated Flange	10271	18
8	Compression Spring	24461	1
9	Roll Pin, 3/16" x 1-1/4"	10302	1
10	Deflector Pivot	22426	2
11	Inner Deflector	32196	1
13	Hose Cover	32191	1
14	Cylinder Pin, 3/4" x 3" Usable	22007	2
15	Cotter Pin, 3/16" x 1-1/4"	11669	4
16	Hydraulic Cylinder, 1-1/2" x 6" x 1" * Seal Kit	21711 23738	1
18	Deflector Rubber Flipper	24463	1
19	Outer Deflector	31754	1
20	Nut, 1/2" Serrated Flange	10273	12
21	Bolt, 1/2" x 1"	10824	8
22	Bolt, 1/2" x 2"	10322	1
23	Deflector Lock	22422	1
24	Pin Stud	13231	1
25	Lynch Pin	13233	1
27	Flat Washer, 3/8"	11667	10

Main Frame Components

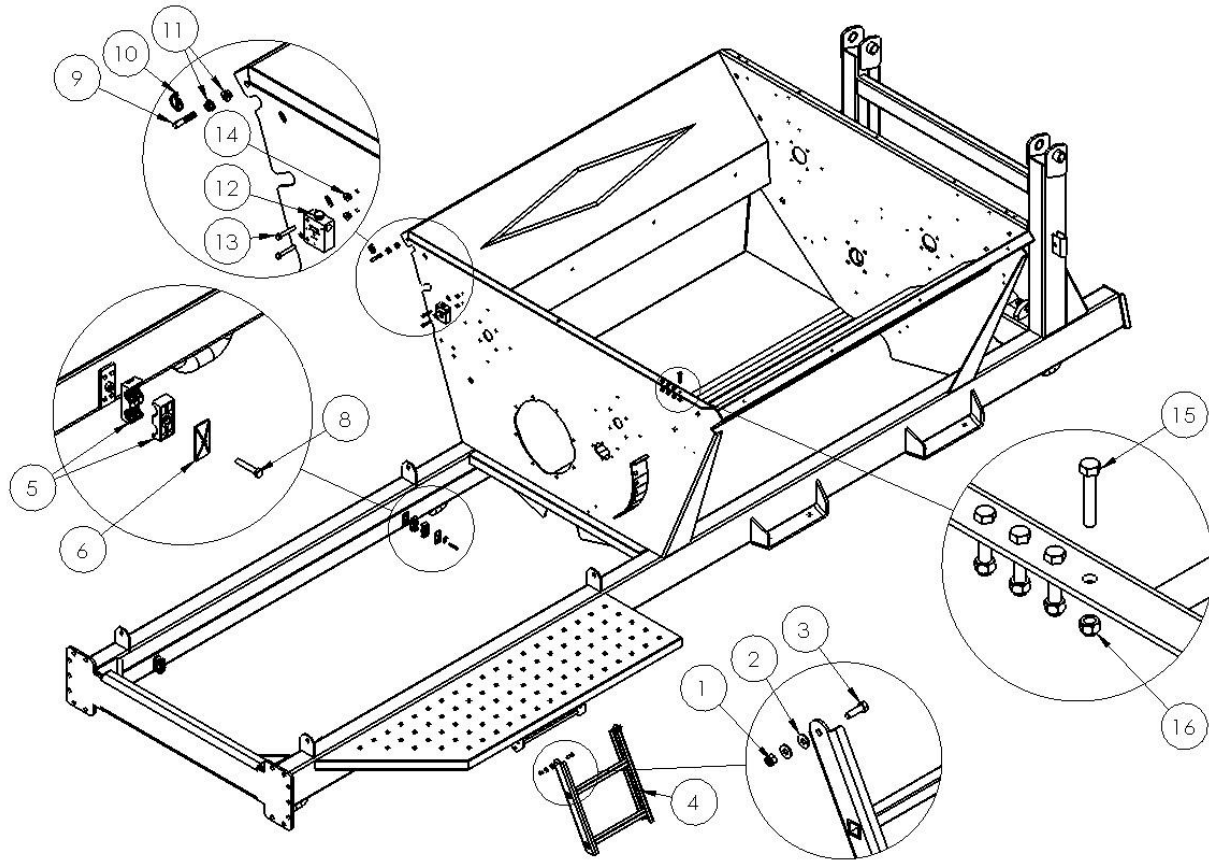

#	DESCRIPTION	PART #	QTY
1	Nut, 3/8" Nylon Lock	10806	2
2	Flat Washer, 3/8"	11667	11
3	Bolt, 3/8" x 1-1/4"	10253	2
4	Grain Tank Step	30362	1
5	Hose Clamp	21561	30
6	Hose Clamp Top	21725	15
8	Bolt, 5/16 x 1-3/4"	21726	15
9	Threaded Pin	13231	1
10	Lynch Pin	13233	1
11	Nut, 1/2" Serrated Flange	10273	2
12	Line Lock Valve	25778	1
13	Bolt, 5/16 x 2"	15572	2
14	Nut, 5.16" Serrated Flange	11814	2
15	Bolt, 3/8 x 2" Fine Thread	33285	4
16	Nut, 3/8" Fine Thread Stover Lock	33286	4

Grain Tank

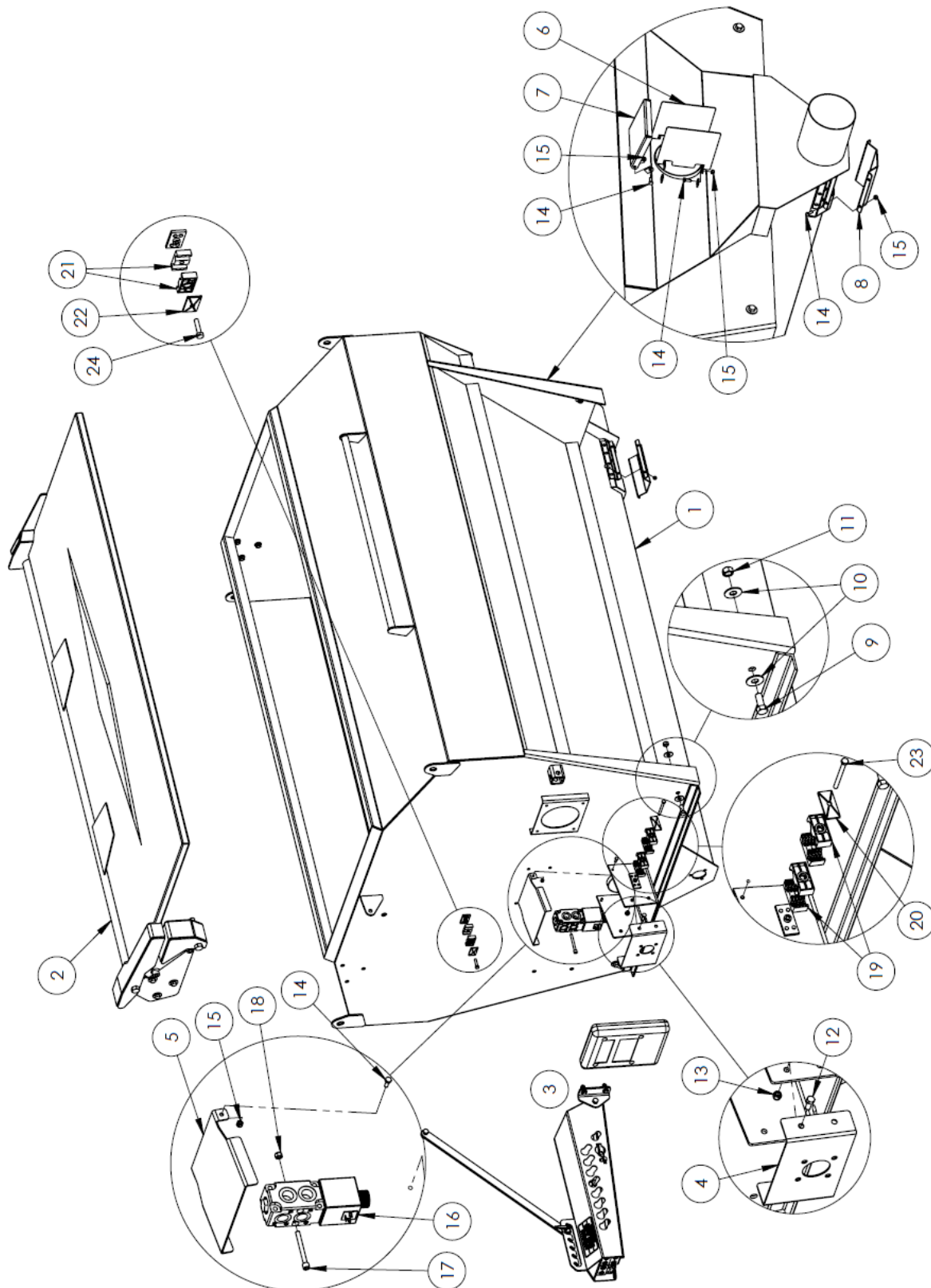

Grain Tank

#	DESCRIPTION	PART #	QTY
1	Grain Tank	30368	1
2	Grain Tank Lid	See Breakdown pg. 59	1
3	Hose Holder & Manual	See Breakdown pg. 63	1
4	PTO Guard Bracket	30377	1
5	Bearing Cover Door	30379	1
6	Rear PTO Shaft Guard	30382	2
7	Rear Driveshaft Top Guard	30383	1
8	Grain Tank Clean Out Door	30380	1
9	Bolt, 1/2 x 1-1/4"	10240	4
10	Washer, 1/2" Flat	11668	8
11	Nut, 1/2" Stover Lock	20154	4
12	Bolt, 3/8 x 1"	13806	4
13	Nut, 3/8" Nylon Lock	10806	4
14	Bolt, 1/4" x 3/4"	11809	12
15	Nut, 1/4" Nylon Lock	11664	12
16	Diverter Valve	11743	1
	*Nut & O-Ring Kit	17977	(1)
	*Magnet Kit	11789	(1)
17	Bolt, 5/16 x 3" Socket Head	11783	2
18	Nut, 5/16" Nylon Lock	11815	2
19	Hydraulic Hose Clamp, 1/2"	21561	4
20	Hydraulic Hose Clamp Top	21725	1
21	Hydraulic Hose Clamp, 1/4"	22181	2
22	Hydraulic Hose Clamp Top, 1/4" hose	22182	1
23	Bolt, 5/16" x 3-1/2"	13765	1
24	Bolt, 5/16" x 1-3/8"	22183	1

Grain Tank Lid

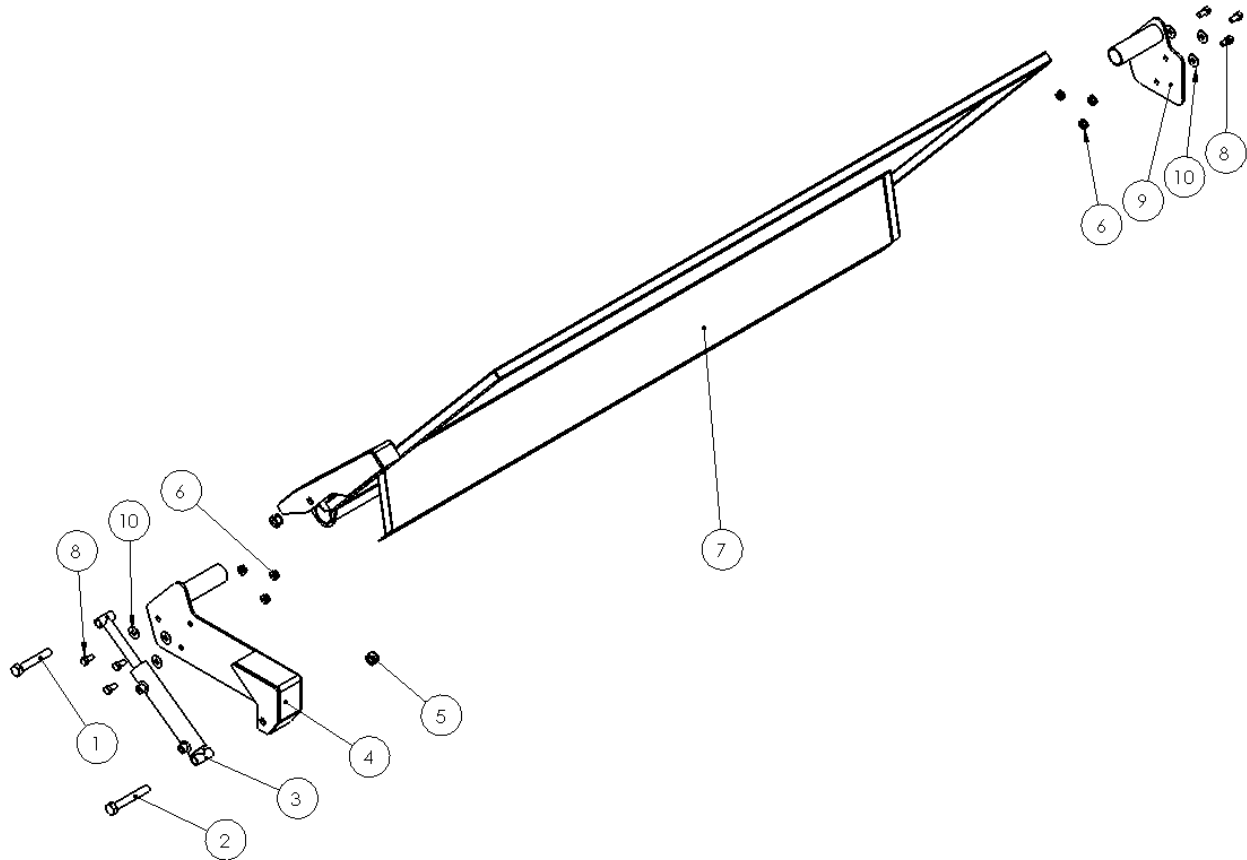

#	DESCRIPTION	PART #	QTY
1	Bolt, 3/4 x 4-1/2"	21460	1
2	Bolt, 3/4 x 5"	17826	1
3	Hydraulic Cylinder, 1-1/2" x 6" x 3/4" * Seal Kit	21711 23738	1
4	Front Lid Hinge Bracket	30376	1
5	Nut, 3/4" Stover Lock	11823	2
6	Nut, 1/2" Serrated Flange	10273	6
7	Grain Tank Lid	30367	1
8	Bolt, 1/2 x 1"	10824	6
9	Rear Lid Hinge Bracket	30375	1
10	Flat Washer, 1/2"	11668	6

Bottom Auger

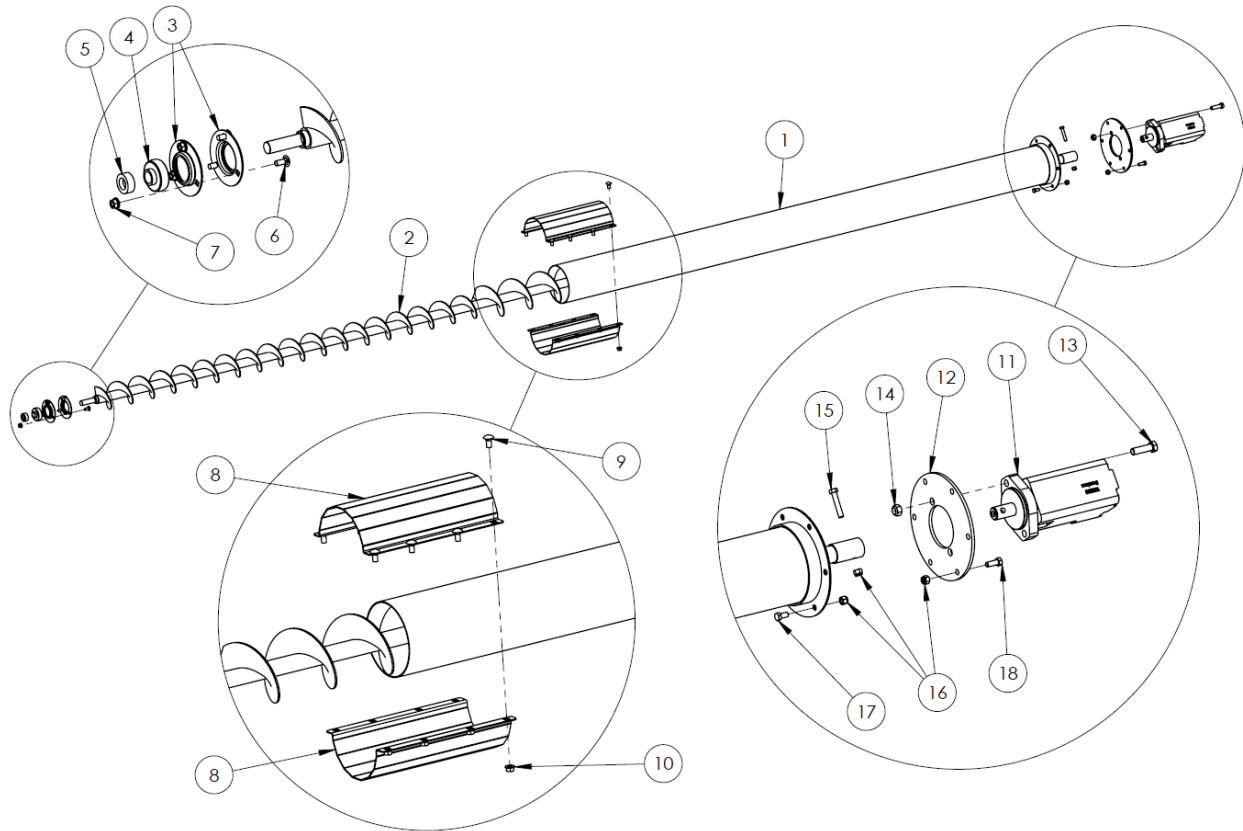

#	DESCRIPTION	PART #	QTY
1	Bottom Auger Tubing	30370	1
2	Bottom Auger	17743	1
3	3-Bolt Pressed Flange Housing	10368	2
4	Bearing, 3/4" with Lock Collar	10366	1
5	Lock Collar Only	10367	1
6	Bolt, 5/16" x 3/4" Carriage	11662	3
7	Nut, 5/16" SF	11814	3
8	Pipe Clamp	30378	2
9	Bolt, 3/8" x 3/4" Carriage	14072	8
10	Nut, 3/8" Serrated Flange	10271	8
11	Bottom Auger Motor	31172	1
12	Bottom Auger Motor Mount	30384	1
13	Bolt, 1/2" x 1-3/4"	10805	2
14	Nut, 1/2" Stover	20154	2
15	Bolt, 3/8" x 2"	10279	1
16	Nut, 3/8" NL	10806	13
17	Bolt, 3/8" x 3/4"	11816	6
18	Bolt, 3/8 x 1"	13806	6

Cross Auger

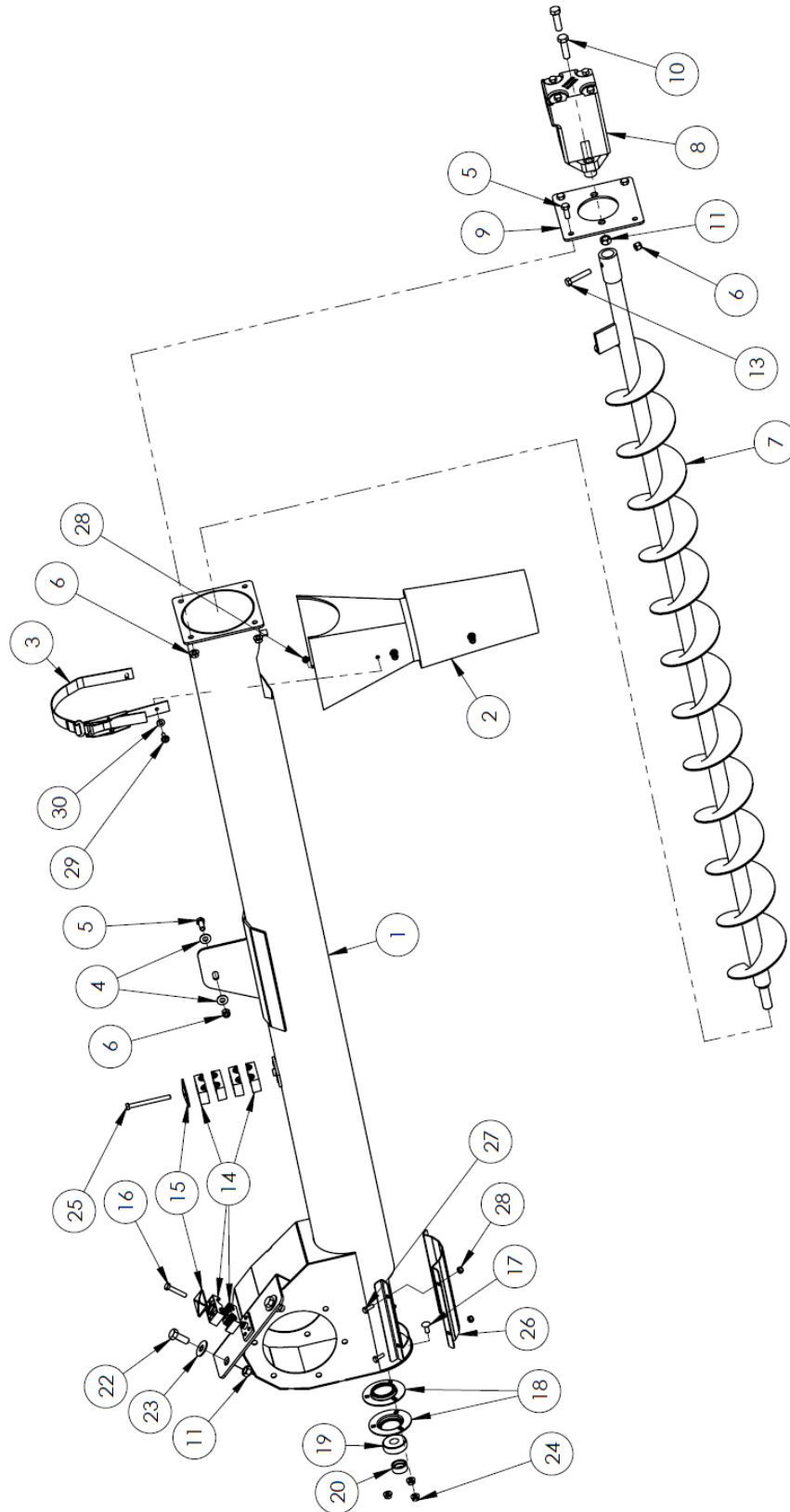

Cross Auger

#	DESCRIPTION	PART #	QTY	
1	Discharge Auger Weldment	30371	1	
2	Auger Spout	10543	1	
3	Auger Spout Strap	25122	1	
4	Washer, 3/8" Flat	11667	2	
5	Bolt, 3/8" x 1"	13806	12	
6	Nut, 3/8" Nylon Lock	10806	6	
7	Discharge Auger	13427	1	
8	Discharge Auger Motor	30132	1	
9	Discharge Auger Motor Plate	30364	1	
10	Bolt, 1/2" x 1-3/4"	10805	2	
11	Nut, 1/2" Stover Lock	20154	4	
13	Bolt, 3/8" x 2"	10279	1	
14	Hose Clamp, 1/2" Plastic Block	21561	6	
15	Hose Clamp, Top Plate (Large)	21715	2	
16	Bolt, 5/16" x 1-3/4"	21726	1	
17	Bolt, 5/16" x 3/4" Carriage	11662	3	
18	3-Bolt Pressed Flange Housing	10368	2	
19	Bearing, 3/4" with Lock Collar	Comes with lock collar	10366	1
20	Lock Collar	10367	1	
22	Bolt, 1/2 x 1-1/4"	10240	2	
23	Washer, 1/2" Flat	11668	2	
24	Nut, 5/16" SF	11814	6	
25	Bolt, 5/16" x 3-1/2"	13765	1	
26	Rear Auger Clean-out Door	30363	1	
27	Bolt, 1/4" x 3/4"	11809	4	
28	Nut, 1/4" Nylon Lock	11664	6	
29	Bolt, 1/4" Truss Head	17638	2	
30	Washer, 1/4" Flat	11666	2	

Hose Holder and Manual Holder

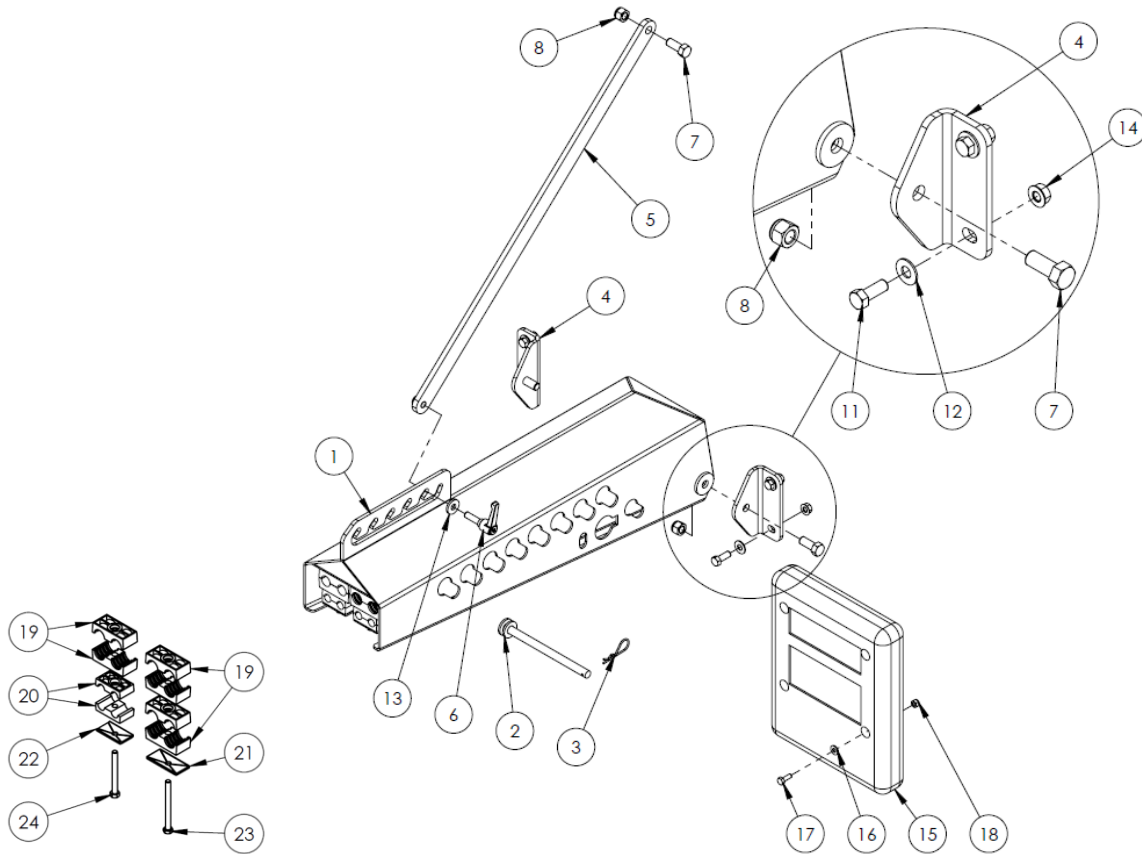

#	DESCRIPTION	PART #	QTY
1	Adjustable Hose Holder	35038	1
2	Hose Holder Pin	31745	1
3	Hairpin, 3/32 x 5/8"	11786	1
4	Hose Holder Pivot Bracket	35041	2
5	Hose Holder Linkage	35040	1
6	Threaded Adjustable Handle	34944	1
7	Bolt, 1/2 x 1-1/4"	10240	3
8	Nut, 1/2" Nylon Lock	10241	3
11	Bolt, 3/8" x 1"	13806	4
12	Flat Washer, 3/8"	11667	4
13	Flat Washer, 3/8" Heavy	33189	1
14	Nut, 3/8" Serrated Flange	10271	4
15	Operator Manual Holder	22409	1
16	Flat Washer, 1/4"	11666	4
17	Bolt, 1/4" x 3/4"	11809	4
18	Nut, 1/4" Nylon Lock	11664	4
19	Hydraulic Hose Clamp, 1/2"	21561	6
20	Hydraulic Hose Clamp, 1/4"	22181	2
21	Hydraulic Hose Clamp Cap, Large	21725	1
22	Hydraulic Hose Clamp Cap, Small	22182	1
23	Bolt, 5/16" x 3-1/2"	13765	1
24	Bolt, 5/16" x 3"	22844	1

Decals

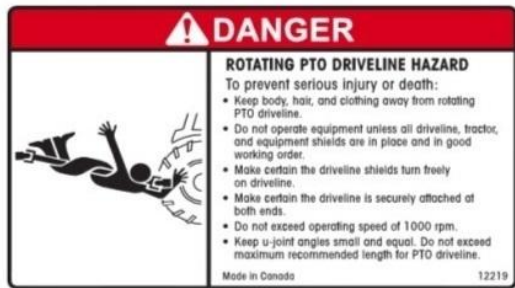

5

2

6

3

4

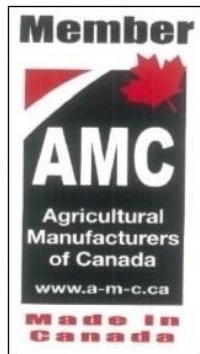

7



8



9



10



11

12

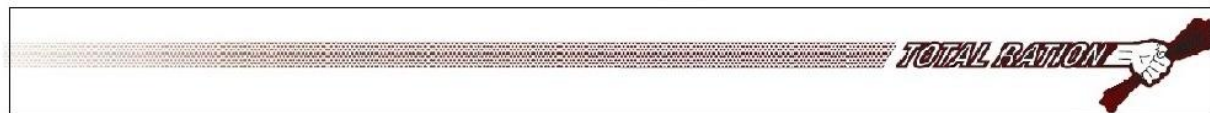

13



14

DECALS

#	DESCRIPTION	PART #	QTY
1	"BALE KING"	32804	2
	"5325"	35811	2
2	"DANGER", PTO	12219	2
3	"DANGER", Discharge	12230	4
4	"DANGER", Stand Clear of Lift	12229	2
5	AMC Member	12239	1
6	FEMA Member	25347	1
7	Wheel Torque Reminder	28385	4
8	Deflector Safety Lock	22292	1
9	Red Reflector	28383	1
10	Amber Reflector	28384	6
11	Hoop Adjustment	32782	1
12	Total Ration	24862	2
13	Speed Limit Decal	33159	1
14	Hyd. Decal	33136	1

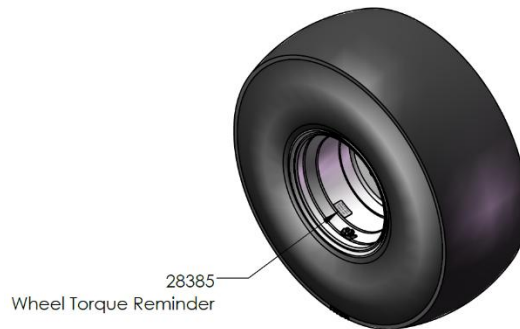
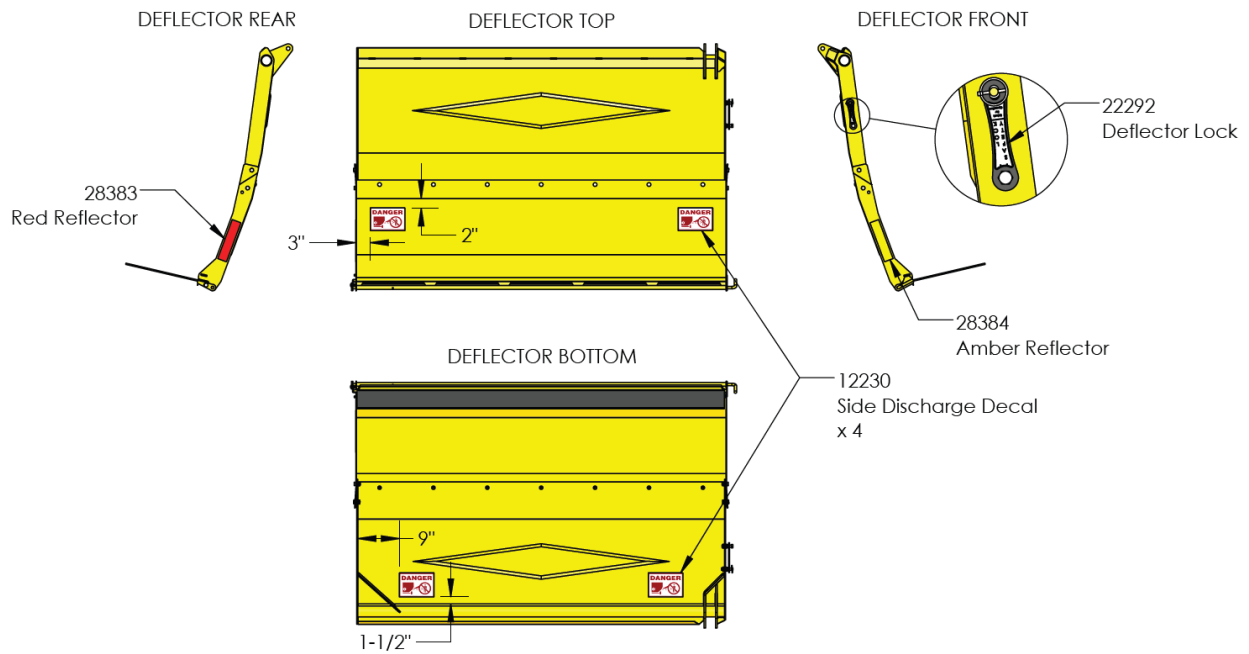

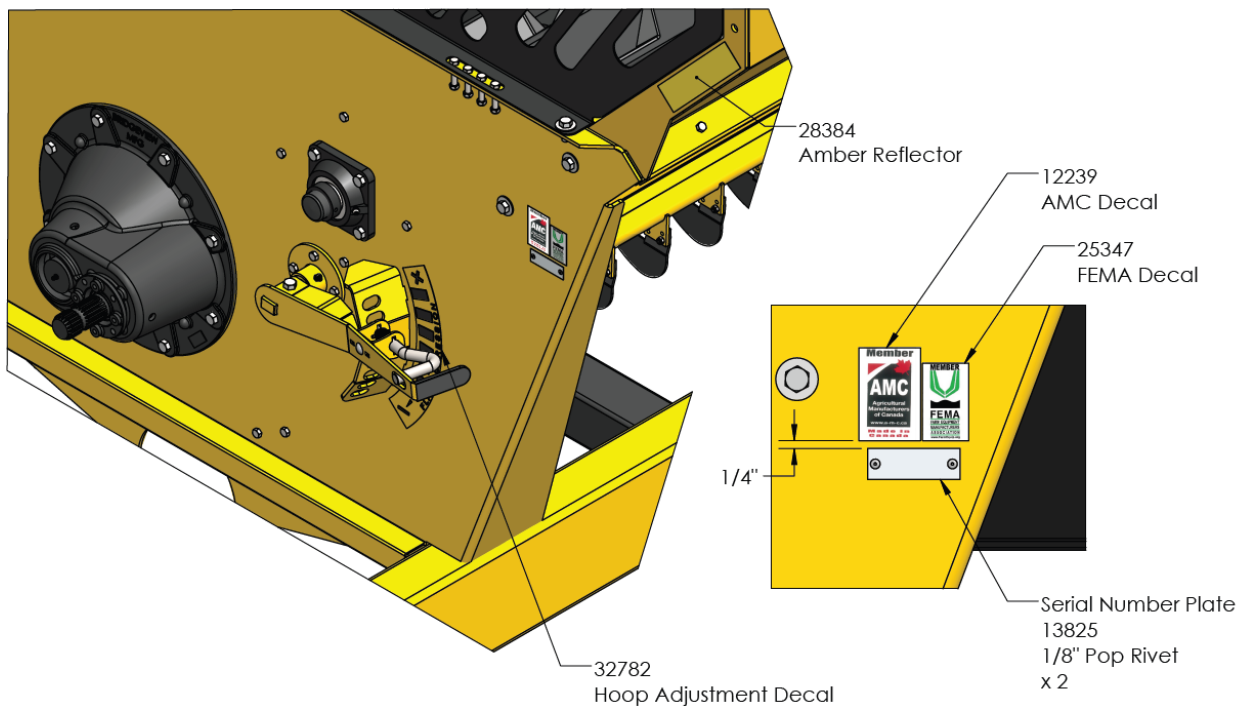
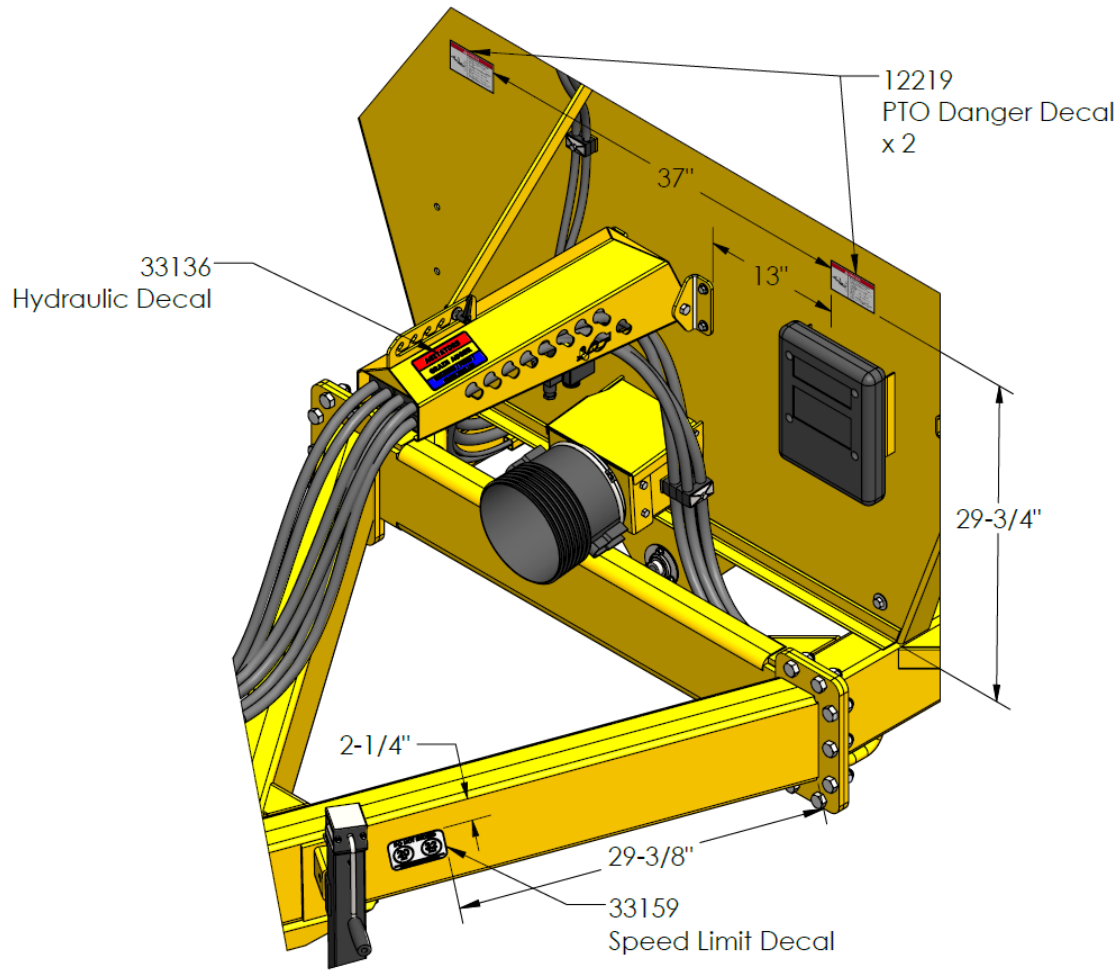

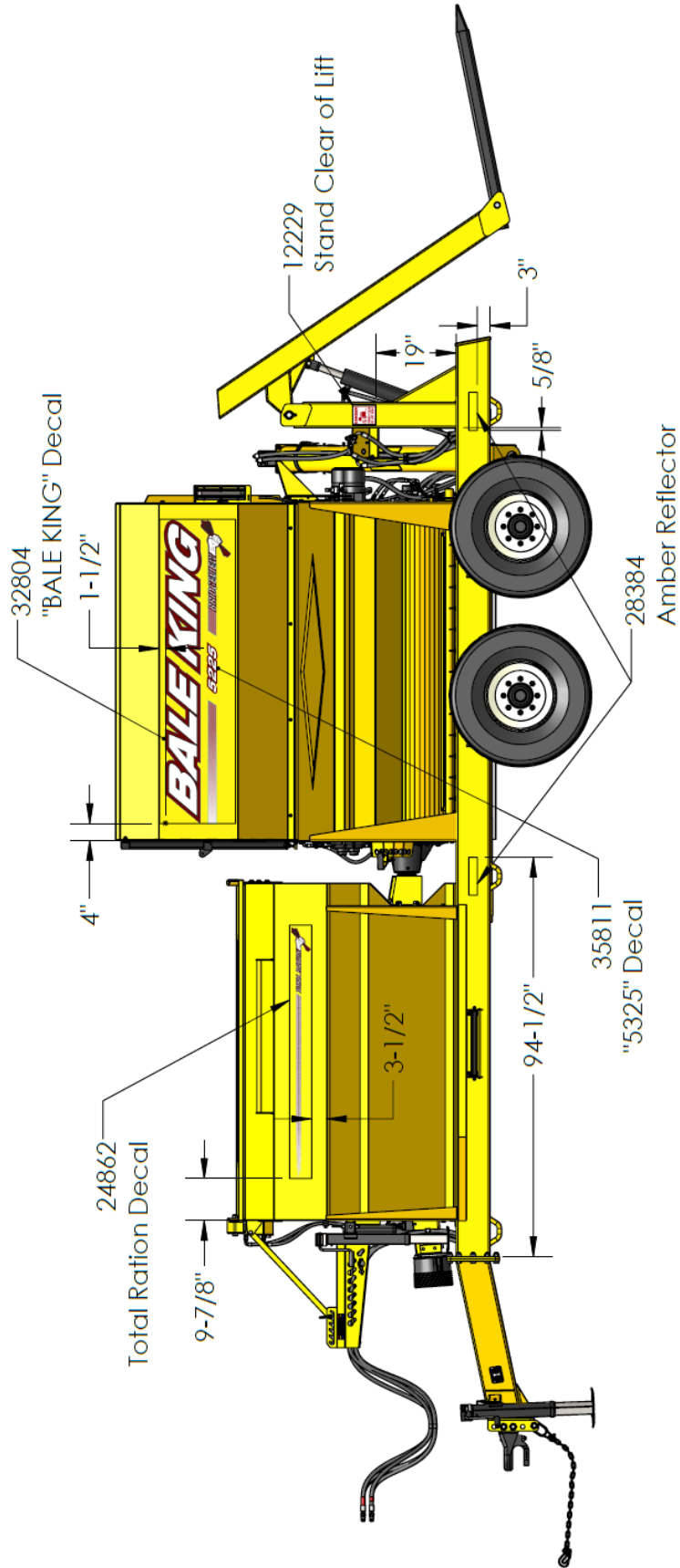

Fine Chop Option #36155

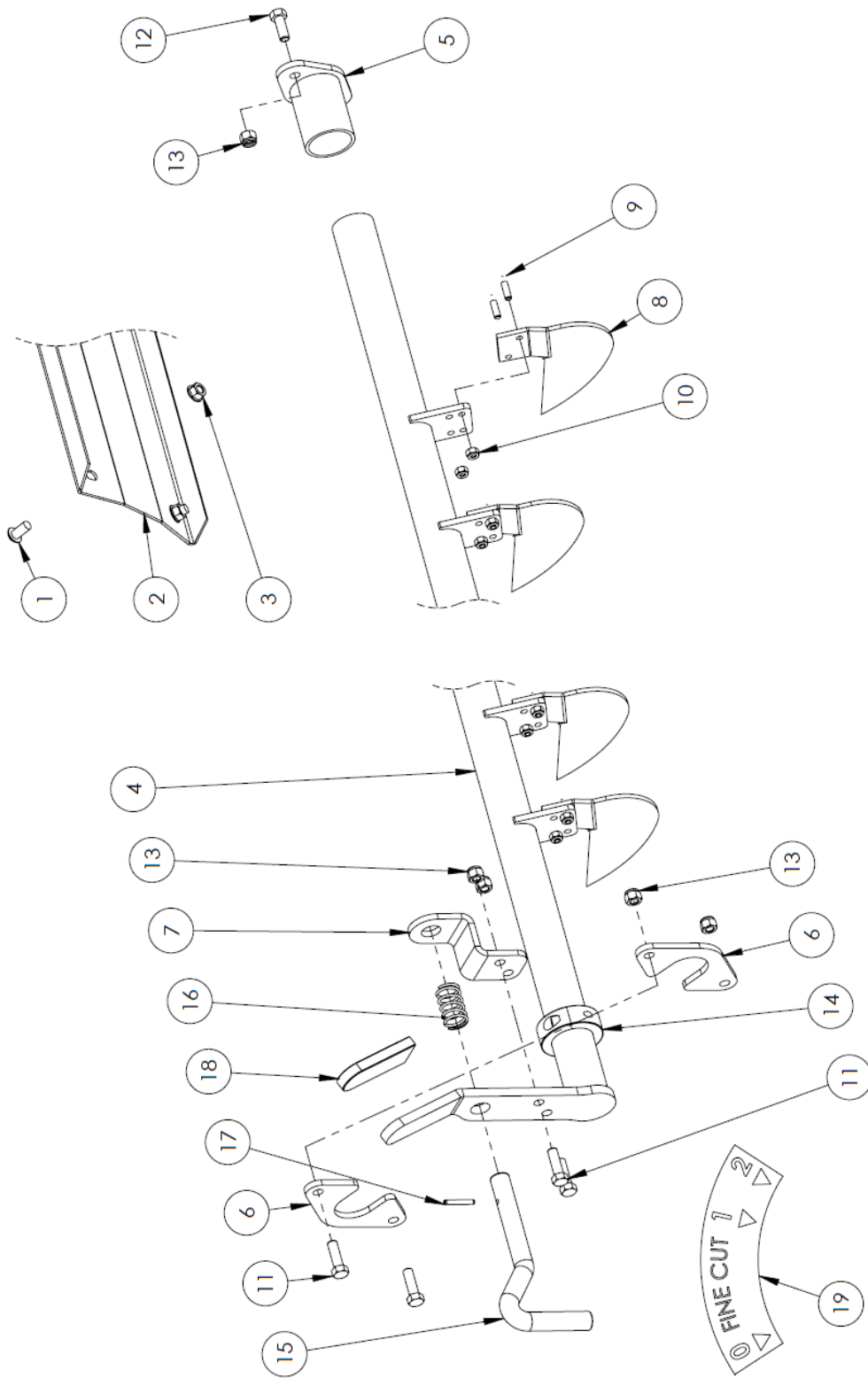

Fine Chop Option

#	DESCRIPTION	PART #	QTY
	Fine Chop Cover * IF NO FINE CHOP INSTALLED *		
1	Fin Bolt, 3/8" x 3/4"	10807	8
2	Fine Chop Cover Plate	30381	1
3	Nut, 3/8" Serrated Flange	11818	8

	Fine Chop Kit * Optional *	36155	1
4	Fine Chop Bar	36164	1
5	Fine Chop Mount Rear	22444	1
6	Fine Chop Front Mount	36163	2
7	Fine Chop Spring Mount	36161	1
8	Fine Chop Knife	10404	13
9	Bolt, 1/4" x 3/4"	11809	26
10	Nut, 1/4" Nylon Lock	11664	26
11	Bolt, 3/8 x 1-1/4"	10253	4
12	Bolt, 3/8" x 1"	13806	2
13	Nut, 3/8" Nylon Lock	10806	6
14	Split Collar	12792	1
15	S-Handle	22187	1
16	Compression Spring	34465	1
17	Roll Pin, 3/16 x 1-1/4"	10302	1
18	Rubber Handle	10297	1
19	Decal, Fine Chop	36031	1

Fine Chop Option #32117

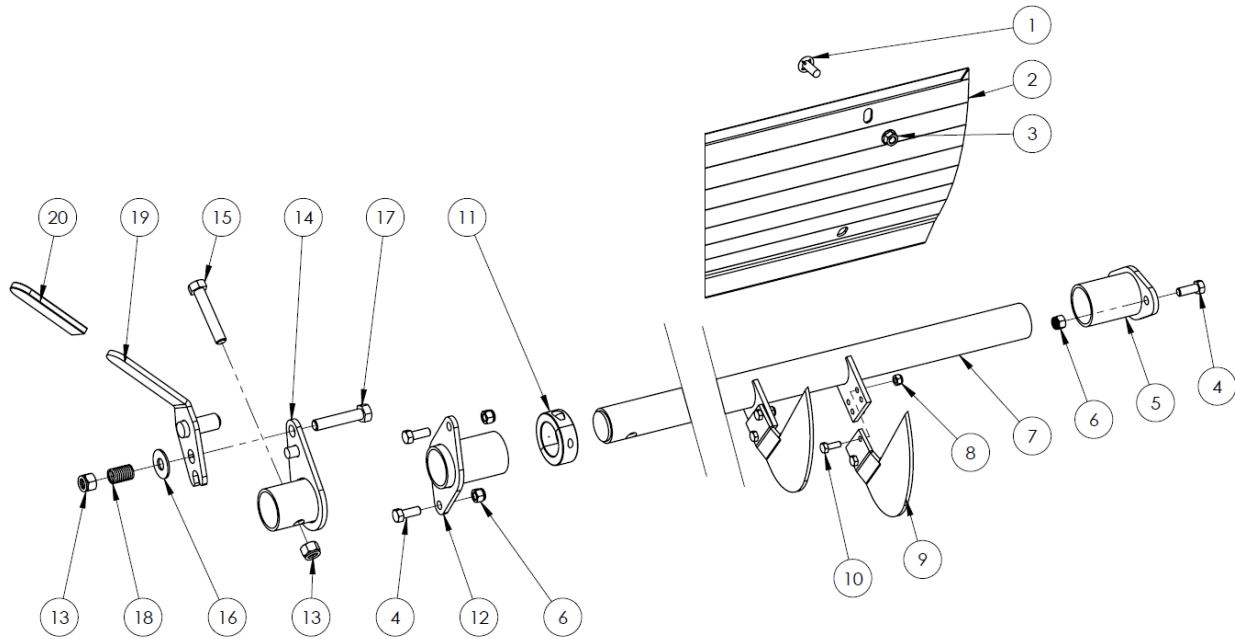

#	DESCRIPTION	PART #	QTY
	Fine Chop Cover * IF NO FINE CHOP INSTALLED *		
1	Fin Bolt, 3/8" x 3/4"	10807	8
2	Fine Chop Cover Plate	30381	1
3	Nut, 3/8" Serrated Flange	10271	8

	Fine Chop Kit * Optional *	32117	1
4	Bolt, 3/8" x 1"	13806	4
5	Fine Chop Mount	22444	1
6	Nut, 3/8" Nylon Lock	10806	4
7	Fine Chop Bar	32118	1
8	Nut, 1/4" Nylon Lock	11664	26
9	Fine Chop Blade	10404	13
10	Bolt, 1/4" x 3/4"	11809	26
11	Split Collar	12792	1
12	Fine Chop Front Mount	32122	1
13	Nut, 1/2" Nylon Lock	10241	2
14	Fine Chop Pivot	32127	1
15	Bolt, 1/2" x 2-3/4"	12378	1
16	Flat Washer, 1/2"	11668	1
17	Bolt, 1/2" x 2-1/2"	10804	1
18	Compression Spring	21713	1
19	Fine Chop Handle	32132	1
20	Rubber Cover	10297	1

Twine Cutter Option

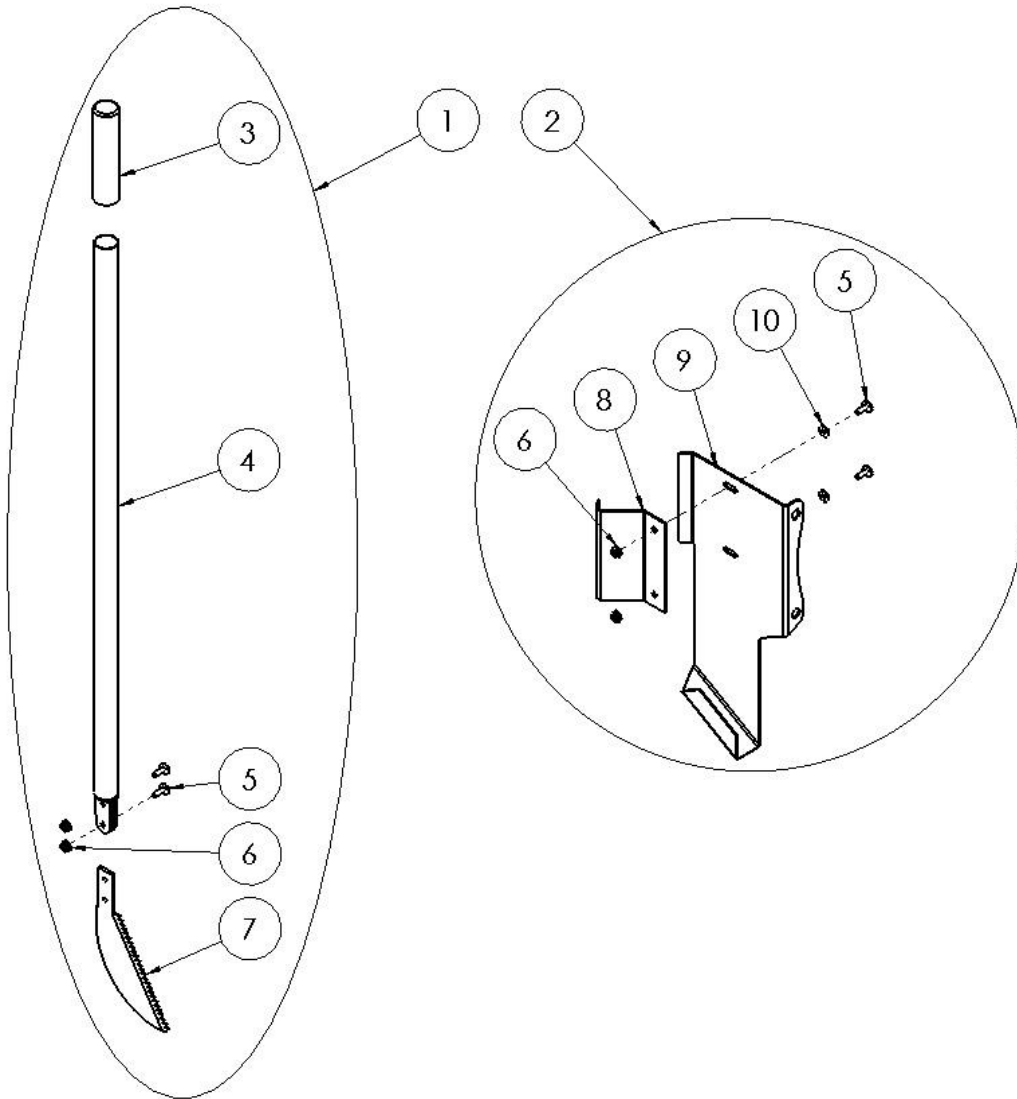

#	DESCRIPTION	PART #	QTY
	Twine Cutter Kit	17686	1
1	Twine Cutter Handle Kit	-	1
2	Twine Cutter Holder Kit	21549	1
3	Rubber Handle Cap	17587	1
4	Twine Cutter Handle	20862	1
5	Bolt, 1/4" x 3/4" Truss Head	17638	4
6	Nut, 1/4" Serrated Flange	11812	4
7	Twine Cutter Blade	17438	1
8	Twine Cutter Holder Inside Bracket	17690	1
9	Twine Cutter Holder Outside Bracket	17691	1
10	Flat Washer, 1/4"	11666	2

Back-up Camera Option

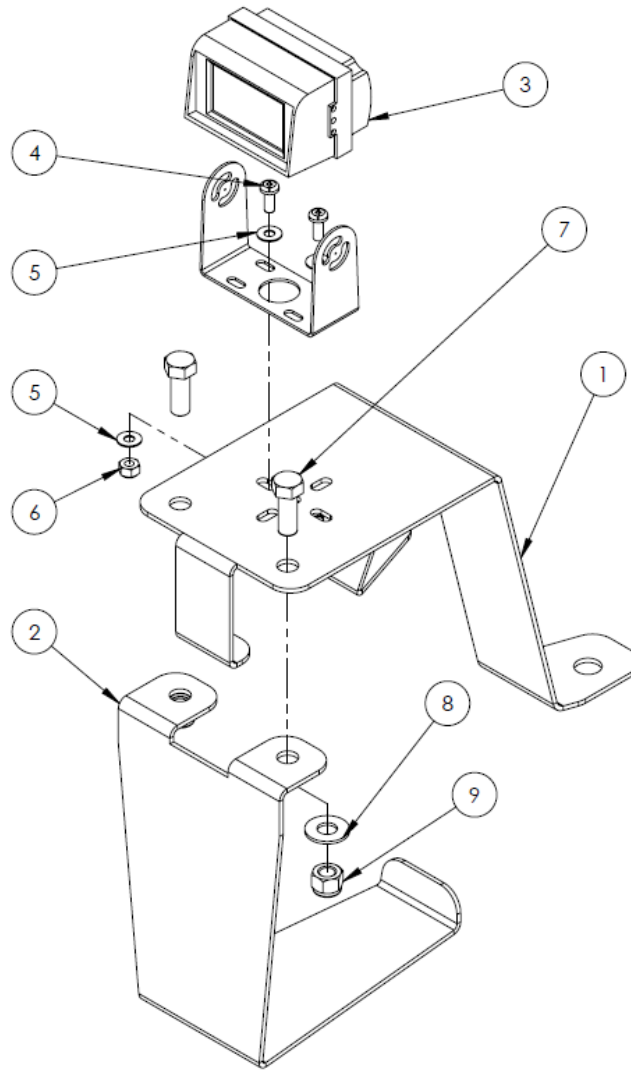

#	DESCRIPTION	PART #	QTY
	Complete Back-up Camera Kit - Standard	33879	-
	Complete Back-up Camera Kit - Pro	33880	-
1	Camera Mounting Bracket	33877	1
2	Camera Mounting Strap	33878	1
3	* Back-up Camera – Standard	32640	1
	* Back-up Camera – Pro	32639	
4	Bolt, #10 x 1/2"	17035	2
5	Washer, #10 Flat	25600	4
6	Nut, #10 Nylon Lock	31110	2
7	Bolt, 3/8 x 1"	13806	2
8	Washer, 3/8" Flat	11667	2
9	Nut, 3/8" Nylon Lock	10806	2
10	Extension Cable, 15'	32645	1

***NOTE: Camera package comes with camera bracket, monitor, and harnesses**

Diverter Control Box

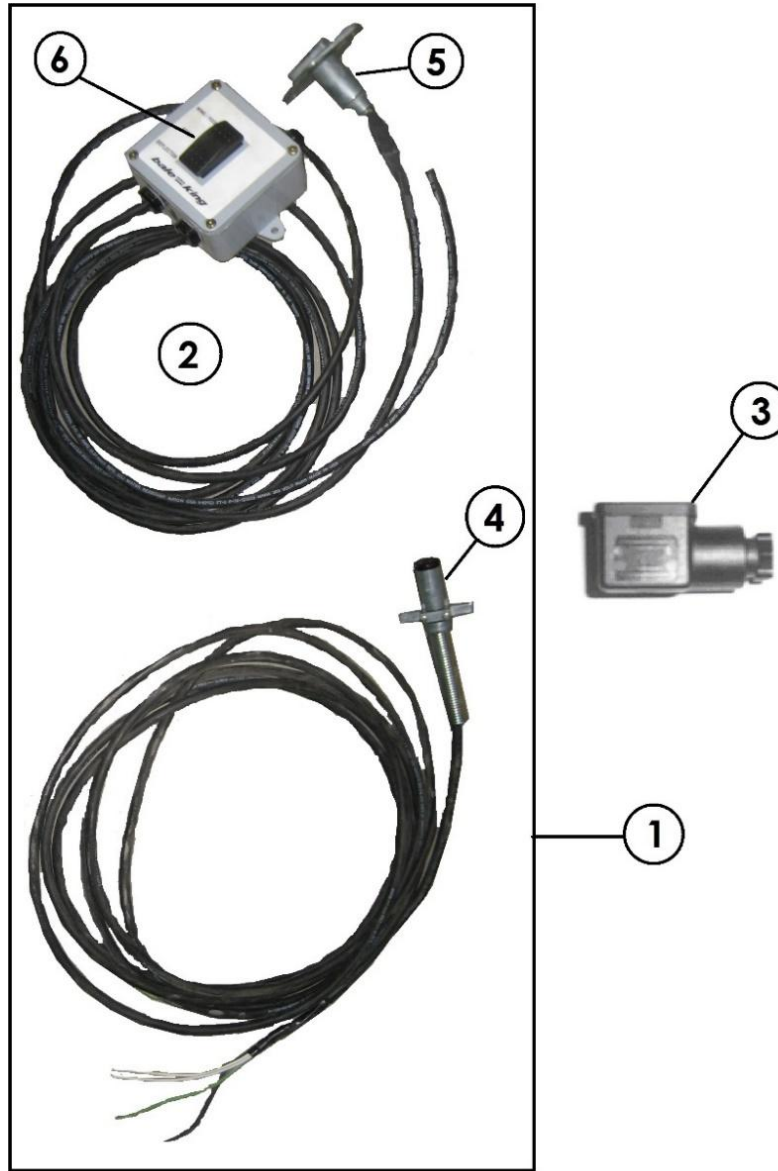

#	DESCRIPTION	PART #	QTY
1	Complete Control Box with Harness (Standard) Complete Control Box with Harness (4 Function) #	24466 33134	1
2	Complete Control Box with Cab to Hitch Harness (5300 Series)	-	1
3	Square Plug for Diverter Valve	13657	*
4	4-pin Trailer Plug	24691	1
5	4-pin Tractor Plug	24690	1
6	3-way Switch	13561	1

* NOTE: 1 plug is needed for each diverter valve.

Diverter Machine Side Harness

FRONT DIVERTER TO REAR DIVERTER HARNESS

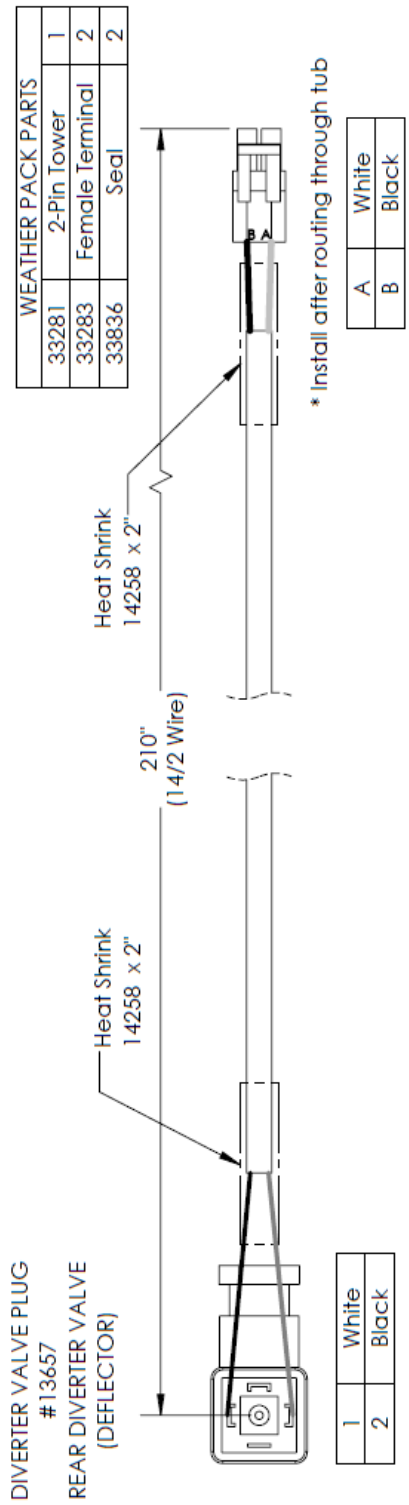

FRONT DIVERTER TO TRACTOR HARNESS

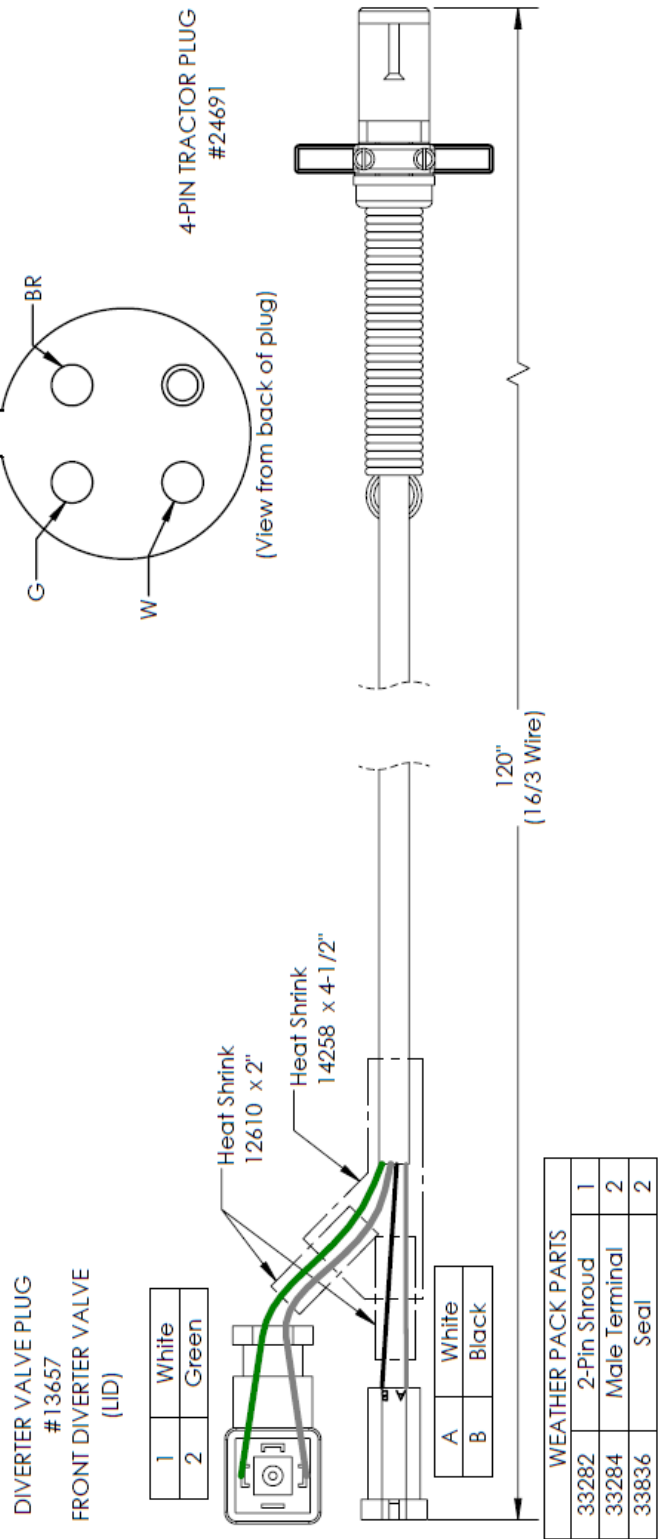

Diverter Control Box #24466

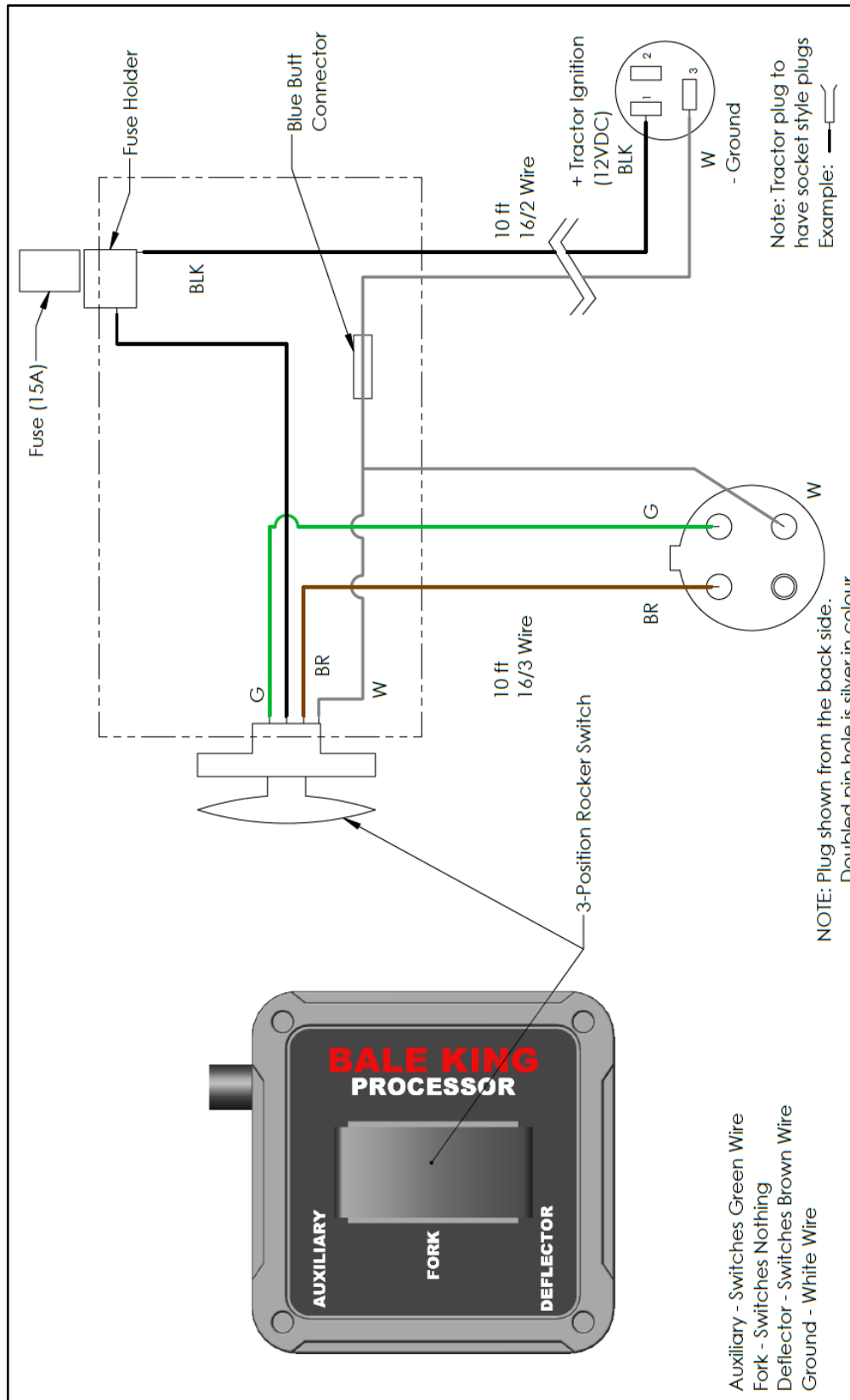

Hydraulic Schematics

HYDRAULIC FITTINGS

#	DESCRIPTION	PART #
A	Adaptor, 12MB - 8MJ90	22174
B	Adaptor, 10MB - 8MJ	10161
C	Adaptor, 10MB - 8MJ90	12169
D	Adaptor, 10MB - 8MJ45	23844
E	Adaptor, 10MB - 6MJ	11739
F	Adaptor, 10MB - 6MJ90	12168
G	Adaptor, 10MB - 6MJ45	22722
H	Adaptor, 8MB - 8MJ	10561
J	Adaptor, 8MB - 6MB90	33739
K	Adaptor, 8MBR - 8MJT	22159
L	Adaptor, 8FJXL - 8MJT	
M	Adaptor, 6MBL - 6MJT	27678
N	Adaptor, 6MB - 6MJ Orifice (1/32")	17436
P	Adaptor, 6MB - 6MJ90	10201
Q	Adaptor, 6MJ - 6FJX90	12162
R	Adaptor, 6MJBH45	21319
S	Adaptor, 6MJBHL - 6MJT	10188
T	Pioneer Tip, 8FB	17379
U	Check Valve, 8MJ - 8FB	12171

NOTE: Quantities vary depending on machine set-up. Order as required.

HYDRAULIC HOSES

#	QTY	Hose Size	Length	End 1	End 2	Location 1	Location 2
1	2	1/2"	106" OAL	8MB	8FJX	Tractor	Diverter Valve 1 (P1,P2)
2	1	1/4"	39" OAL	6FJX	6FJX90	Diverter Valve 1 (C3)	Grain Tank Lid Cylinder (Ram)
3	1	1/4"	34" OAL	6FJX	6FJX90	Diverter Valve 1 (C2)	Grain Tank Lid Cylinder (Base)
4	2	1/2"	215" OAL	8FJX	8FJX90	Diverter Valve 1 (C1,C4)	Diverter Valve 2 (P1,P2)
5a	1	1/2"	352" OAL	8MB	8FJX	Tractor	FDV (3)
5b	1	1/2"	348" OAL	8MB	8FJX	Tractor	FDV (1)
6	1	3/8"	17.25" OAL	6FJX	6FJX90	Left Agit Motor (A)	FDV (2)
7	1	3/8"	13.5" OAL	6FJX	6FJX	Left Agit Motor (B)	FDV (5)
8	1	3/8"	11.25" OAL	6FJX	6FJX90	Right Agit Motor (A)	FDV (4)
9	1	3/8"	8.5" OAL	6FJX	6FJX	Right Agit Motor (B)	FDV (6)
10	1	1/2"	370" OAL	8MB	8FJX90	Tractor	FCV (IN)
11	1	1/2"	263" OAL	8MB	8FJX	Tractor	Check Valve
12	1	1/2"	39" OAL	8FJX	8FJX90	FCV (CF)	Discharge Motor (B)
13	1	1/2"	80" OAL	8FJX	8FJX90	Tank Motor (B)	Discharge Motor (A)
14	1	1/2"	43" OAL	8FJX	8FJX90	Tank Motor (A)	FCV (EX)
15	1	1/2"	108" OAL	8FJX	8FJX90	Check Valve	FCV (EX)
16	1	3/8"	38" OAL	6FJX	6FJX90	Fork Base Valve (3)	Div Valve (C3)
17	1	3/8"	33" OAL	6FJX	6FJX45	Div Valve (C2)	Fork Base Valve (2)
18	2	3/8"	18.75"	6FJX	8FJX90	Fork Line Lock (3)	Fork Ram
19	1	3/8"	36" OAL	8FJX	8FJX	Fork Ram	Fork Ram
20	1	3/8"	69" OAL	6FJX	6FJX	Fork Base (2)	Fork Base (2)
21	2	1/4"	16" OAL	6FJX	6FJX90	Rear Bulkhead	Diverter Valve 2 (C3,C2)
22	2	1/4"	79.5" OAL	6FJX	6FJX	Rear Bulkhead	Front Bulkhead
23	1	1/4"	14" OAL	6FJX	6FJX	Front Bulkhead (Tee)	Line Lock (3)
24	1	1/4"	13" OAL	6FJX	6FJX90L	Front Bulkhead (Tee)	Deflector Cylinder (Ram)
25	1	1/4"	16" OAL	6FJX	6FJX	Front Bulkhead (Bottom)	Line Lock (2)
26	1	1/4"	17.25" OAL	6FJX	6FJX90L	Line Lock (1)	Deflector Cylinder (Base)

NOTE: Hoses are not available for sale. Use the information above to have replacement hoses made up locally.
All hoses should be double braid, with crimps rated for at least 3500 psi.

ROLLERS

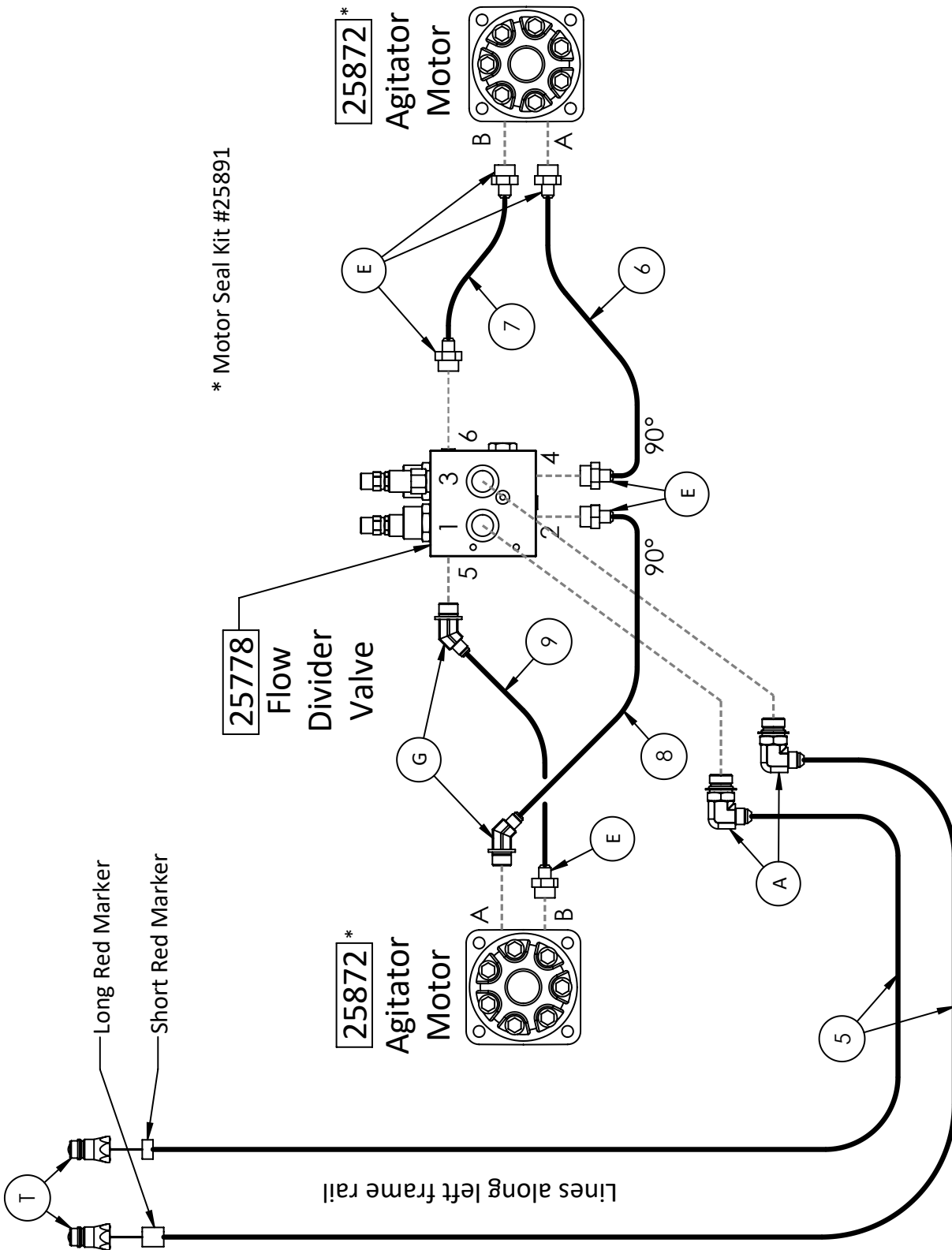

REAR FORK, DEFLECTOR, LID

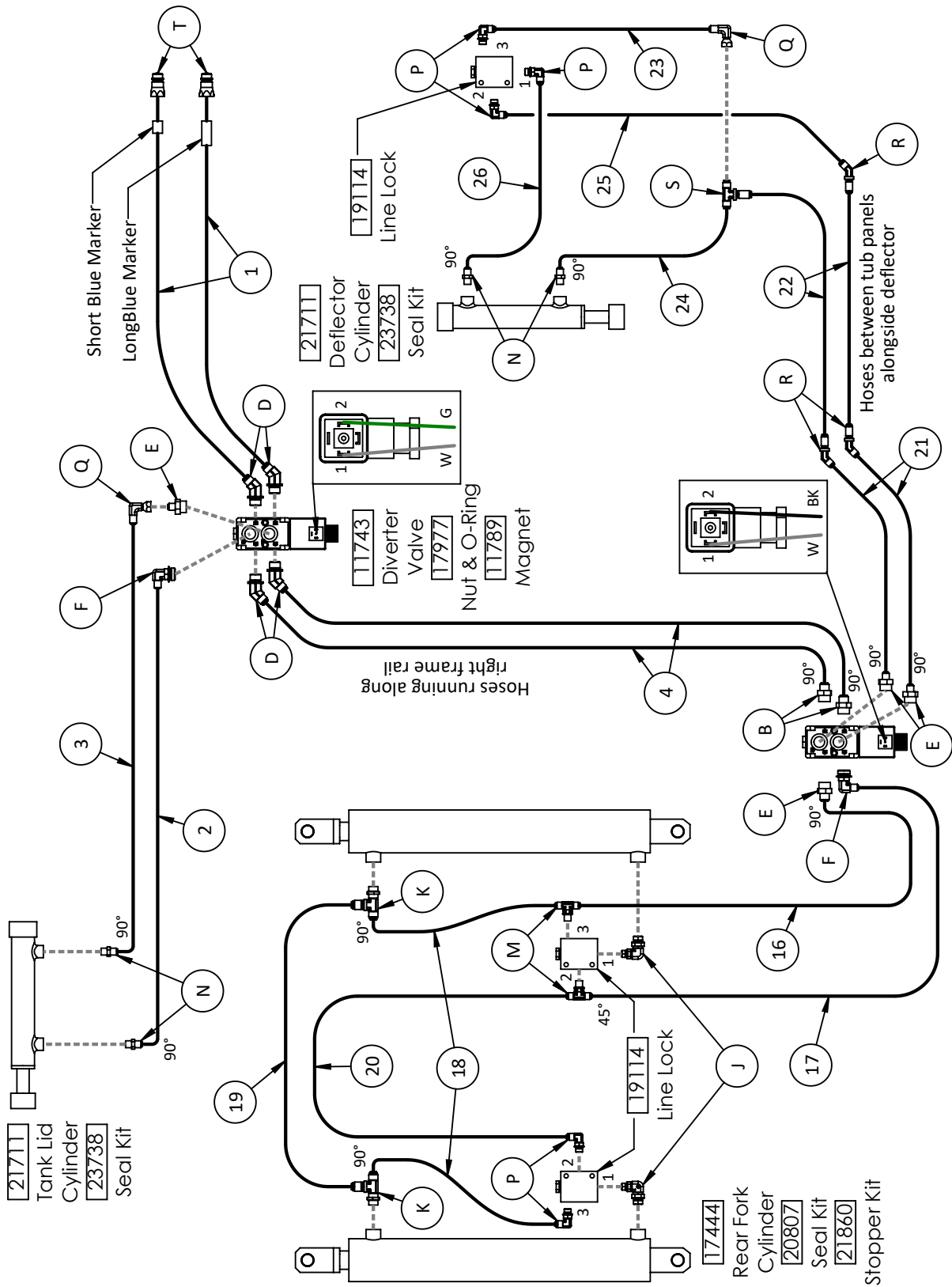

NOTES

A series of horizontal dashed lines for taking notes.