



BRIDGEVIEW MFG. INC.



**SHOWN WITH OPTIONAL 3 BALE KIT*

BALE KING 5400 ***Round Bale Processor***

Operator's & Parts Manual

Last Updated: December 2025

Bridgeview Manufacturing Inc.
P.O. Box 4
Gerald, Saskatchewan, Canada
S0A 1B0
Phone: 1-306-745-2711
Fax: 1-306-745-3364
Email: bridgeview@bridgeviewmfg.ca
www.bridgeviewmanufacturing.com

Your Authorized Dealer

Your Serial Number

The Serial Number is located the front tub panel, next to the operator manual box.

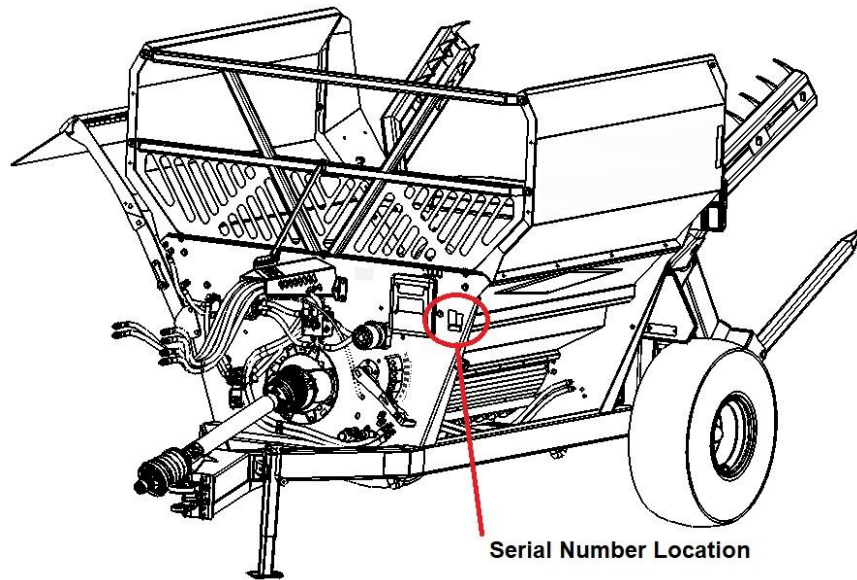

	<p>⚠ WARNING</p> <p>Failure to read and understand operator's manual & all safety signs could result in serious injury. Manual must remain with machine.</p>
---	--

TABLE OF CONTENTS

INTRODUCTION	1
Safety Precautions.....	1
Safety Decals	2
Transportation.....	4
FEATURES & OPERATION.....	6
Power Take-off	6
Hydraulics	10
Hose Holder	14
Implement Tongue	15
Rear Forks.....	15
Loading Bales	16
Setting the Processor.....	17
Hoop Grate Adjustment	17
Bale Roller Speed	18
Rotation Direction.....	18
Deflector	19
Optional Diverter Kit	21
Optional Rotary Straw Assist “Kicker” Kit.....	22
Optional Fine Chop Kit.....	23
Optional Total Ration Grain Tank (5400TR)	24
Optional 3 Bale Kit (5400X).....	25
Optional Back-up Camera.....	29
SERVICE AND MAINTENANCE	30
Greasing Locations	30
Tires	34
Twine Removal.....	35
Gearbox and Flail Replacement Procedure.....	37
Trouble-shooting Guide	38
Features and Specifications.....	39
PARTS MANUAL.....	41
HYDRAULIC SCHEMATICS.....	90
NOTES.....	117

INTRODUCTION

Thank you for purchasing a **Bale King** bale processor. With the proper operation and service as outlined in this manual, the Bale King will provide you with years of trouble-free operation.

This is a complete safety, operation and parts manual for the Bale King 5400. The manual covers in detail how to safely and effectively use your new processor. The procedures outlined in this manual should be followed to ensure safe operation and longevity of your machine. The parts manual covers all parts you may need to order in case of accident or breakdown. Please read completely through this manual before beginning operation of your new machine.

Safety Precautions

The following safety precautions MUST be followed to ensure safe operation of the Bale King bale processor.

- **ALWAYS** turn **OFF** the tractor when leaving the operating platform.
- **DO NOT** stand in front of the discharge chute while the machine is running.
- **DO NOT** walk or move under the bale forks when they are in the upward position, unless the cylinder safety lock is in place.
- **DO NOT** enter the machine while in operation.
- **DO NOT** clean machine while in operation.
- **DO NOT** stick any device into the machine to clear debris while the machine is in operation.
- **ALWAYS** turn off the machine when cleaning the machine, removing twine, or hooking/unhooking the machine
- **ALWAYS** use safety chain when towing the machine on a highway.
- **DO NOT** operate if any part of the **PTO safety shielding** is missing or is not secured.

Safety Decals

Power Take-off:

The operator must obey all safety labels and must maintain the proper shielding. A high percentage of drive-line injuries occur when safety shielding is missing or not functioning properly.

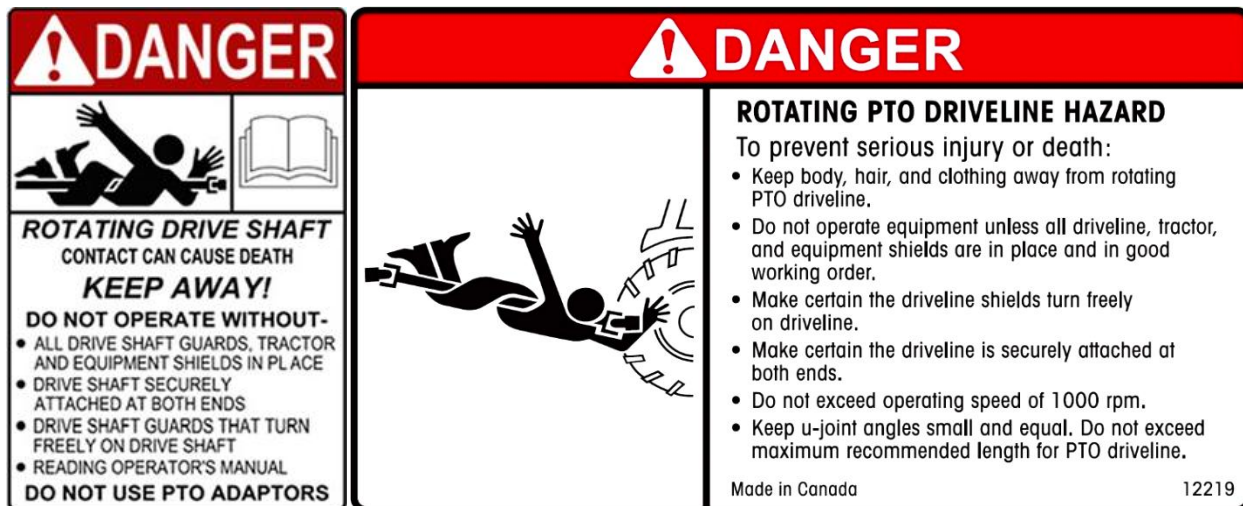

DANGER: *Contact with a rotating driveline can cause serious injury or death.*

Discharge:



DANGER: *Do not stand on the discharge side of the machine while it is in operation.*

Rear Fork Lift Area:



DANGER: *Stand clear of lift area. Do not stand under the forks if tractor is running or if bale is resting on forks. Automatic hydraulic safety locks are installed.*

Deflector Safety Lock:

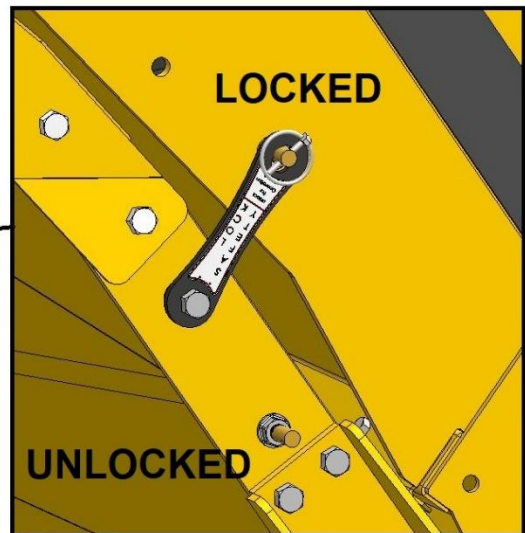

Unlock for operation, Lock for transport and storage

Transportation

The Bale King 5400 can be safely towed on public roads, provided the following precautions are met:

Weights and Dimensions

- The towing vehicle must be suitable for the weight being towed.
- Check with local authorities regarding transport on public roads. Follow all applicable laws and regulations.
- Be aware of your size and weight. Adjust your driving accordingly

	Empty			Loaded		
	5400	5400X ¹	5400TR ²	5400	5400X ¹	5400TR ²
Total Weight	4770 lb	5100 lb	5600 lb	8400 lb	10 400 lb	10 850 lb
Hitch Weight	1475 lb	1475 lb	1650 lb	1400 lb	1100 lb	2000 lb
Length	16'-8"	16'-8"	16'-8"	20'-9"	20'-9"	20'-9"
Width ³	10'-0"	10'-0"	11'-0"	10'-0"	10'-0"	11'-0"
Height	9'-7"	9'-7"	9'-7"	10'-0"	11'-8"	10'-0"

NOTE 1. The 5400X features the optional 3-bale kit

NOTE 2. The 5400TR features the optional Total Ration grain tank

NOTE 3. Width can be reduced to 8'-6" by folding the deflector

Speed

Tow Vehicle Weight	Empty Processor	Loaded Processor
10000 lb and Under	32 km/h (20 mph)	Not recommended
Over 10000 lb	40 km/h (25 mph)	32 km/h (20 mph)

- The processor features implement tires and hubs and is not suitable for high speed travel
- The processor does not have brakes.
- Slow down for rough conditions, turns, and steep declines.
- If towing long distances, ensure the machine is empty (no bales in tub or on fork)
- If hauling one bale only, place it in the tub instead of on the fork.
- If hauling two or more bales, speed should be further reduced. Note that there will be a significant amount of weight behind the processor axle, causing more "tail whip". This also raises the center of weight of the machine.
- Failure to heed these warning may result in loss of control or death.

Safety Chain, Jack, PTO, and Hydraulics

- ALWAYS ensure that the safety chain is properly installed. There should be enough slack to allow for turning, but not so much that the chain drags on the ground.
- Ensure that the jack is installed in its storage position on the front tub wall.
- Ensure that the PTO and hydraulic hoses are properly secured
- PTO and hydraulic lines must be connected to the tractor during transport.
- If towing with a pickup, the outer PTO shaft must be removed, and the inner shaft and hydraulic hoses properly secured. The exposed end of the inner PTO shaft should be covered to protect the splines from dust/rocks, etc.

Wheels and Tires

- Check tire pressure and wheel torque. Wheels must be retorqued after 1 hr if being transported for the first time.

Tire Pressure	24 psi	Wheel Torque	125 ft-lb
----------------------	--------	---------------------	-----------

- If transporting long distances, periodically check the tires and hubs for high temperatures. If heating up, you must slow down.

Lights and Marking

- Tow vehicle must have a 7-pin round trailer plug
- Plug in lights and check for proper function and visibility (flashing amber lights, red tail lights and brake lights).
- If towing with a pickup, an adapter will be required to plug into the trailer plug. When braking, both amber lights should activate. Tail lights should always be on.
- Ensure that the supplied SMV (Slow Moving Vehicle) sign is clearly visible from the rear
- Ensure that the reflective markers are cleaned, and visible from all sides

Safety Locks

- Lift the forks all the way up. If carrying a bale, only lift enough for appropriate ground clearance.
- If applicable, the 3-bale clamp should be closed.
- If possible, the deflector should be in the folded position.
- Ensure that the deflector safety lock is installed



FEATURES & OPERATION

Power Take-off

The Bale King processor has a PTO shaft which is splined on both ends. The implement end uses a 1-3/4"-20 spline with 2 clamping bolts. Install onto the gearbox (one each direction for balance) and tighten evenly. The bolts should be torqued to **160 ft-lb** and re-torqued after 8 hours of use.

The tractor end comes standard with a 1-3/8"-21 spline quick detach constant velocity joint. An optional 1-3/4"-20 spline yoke is available through your Bale King dealer.

<p style="text-align: center;">MAXIMUM 150 HORSEPOWER TRACTOR PTO</p>
--

NOTE: *Spread yokes and twisted drive shafts are signs of OVERLOAD, not a manufacturer's defect and therefore not covered by warranty.*

- **DO NOT** operate the machine using a spline adaptor. Use of adaptors will **void warranty** due to damage caused to the tractor PTO, PTO driveshaft, or implement.
- **DO NOT** operate at 540 rpm, or use any kind of adaptor to connect to a 540 rpm spline.
- **ALWAYS** ensure that the PTO shaft is attached securely to the tractor. When the processor is not hooked to the tractor, store the shaft on the PTO holder.
- **DO NOT** transport the processor without securing the PTO shaft. See next page for securing instruction.
- **ALWAYS** ensure that the drawbar is adjusted to **16"** from the end of the tractor PTO shaft to the center of the hole in the drawbar.

Operation

To engage the rotor for processing a bale, be sure the PTO shaft is properly connected to the tractor. Engage the PTO at idle. After the PTO is fully engaged, increase PTO speed until it reaches 1000 RPM.

The processor must not run at any speed less than 1000 PTO RPM as it may result in the flails springing back against the rotor after they come in contact with the bale. This "**backslap**" may cause flails to fatigue and excessive vibration which may cause the bearings to fail. Bales may be dumped into the tub while the rotor is stopped or while it is running at full speed.

Shear Bolt

All new Bale King processors are equipped with a **shear bolt** clutch located at the implement end of the PTO shaft. The correct size shear bolt is **3/8 x 2" Fine Thread Grade 5 with Stover Lock Nut**. Any other size or grade will **damage** the shear assembly. Spare shear bolts are shipped with each new machine and are stored along the front top lip of the tub.

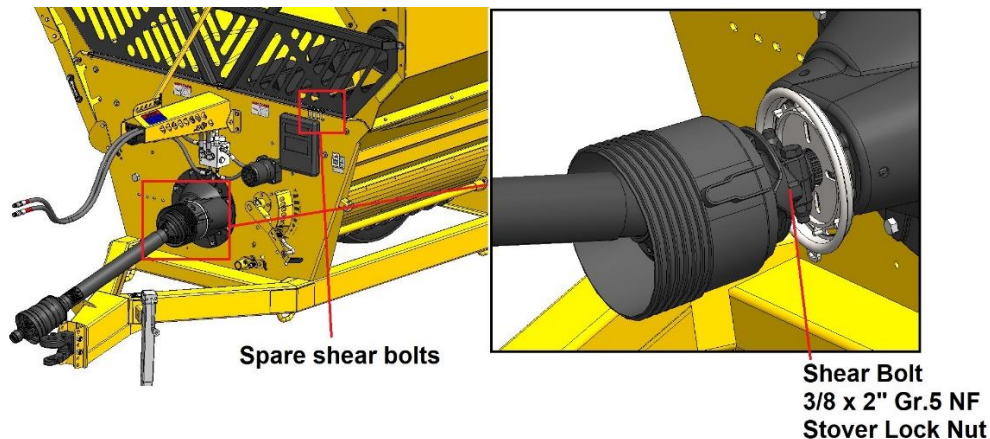

If your shear bolt is shearing excessively you may be over-loading the machine. If this occurs raise the grate assembly to make the machine less aggressive, or roll the bale more slowly by slowing down the rollers. **Always ensure that your machine is running at 1000 PTO RPM.**

NOTE: Please consult your local dealer to help pinpoint any problems.

PTO Holder

A PTO shaft holder is standard with your new Bale King, for safe storage of the PTO shaft when the processor is not in use.

When unhooking the PTO shaft from the tractor, retract and then swing the PTO to the right to rest the PTO on the holder.

DO NOT transport the machine with the PTO in the holder. Slide the outer PTO shaft out and secure elsewhere.

When transporting, fasten the inner PTO shaft to the machine and cover the open splined end.

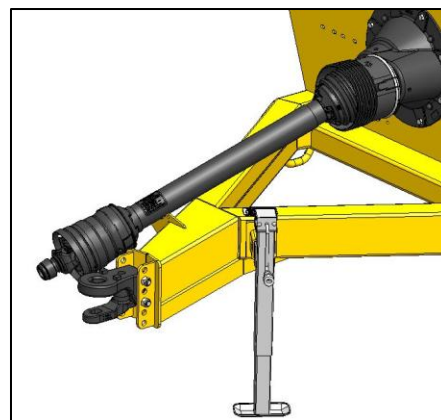

PTO Use and Maintenance

Shut **OFF** the tractor engine and remove the key before doing any maintenance on the machine. Use **ONLY** genuine **Weasler** parts when replacing any worn or damaged PTO components.

Length:

Confirm the minimum and maximum working lengths of the drive-line. The telescoping tubes must overlap at least 1/3 of their length when in use. The PTO is designed to be used with a drawbar length of 16" from the end of the PTO shaft. Adjust your tractor accordingly.

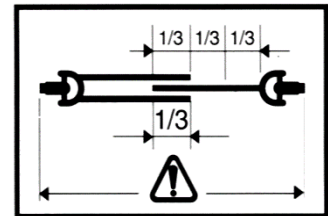

Shielding:

Be sure that the shielding is not damaged and rotates freely on the drive shaft.

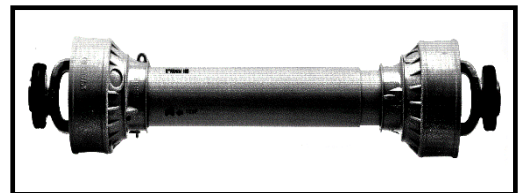

Working Angles:

Constant Velocity joints can operate up to 80 degrees for short periods of time. Do not operate for long periods on sharp angles.

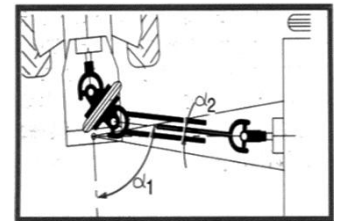

Attachment:

Be sure the drive-line is properly attached and all bolts and screws are tight on the implement input shaft and on the tractor PTO shaft.

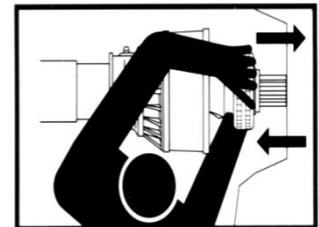

Storage:

When not in use, cover or protect the drive shaft from the weather.

When removed from the machine store both halves together to prevent damage. Check all components for proper function and lubrication before use.

**BEFORE ATTEMPTING ANY REPAIR PROCEDURES,
ALWAYS USE APPROPRIATE EQUIPMENT SUCH AS
SAFETY GLASSES, SAFETY SHOES, AND GLOVES**

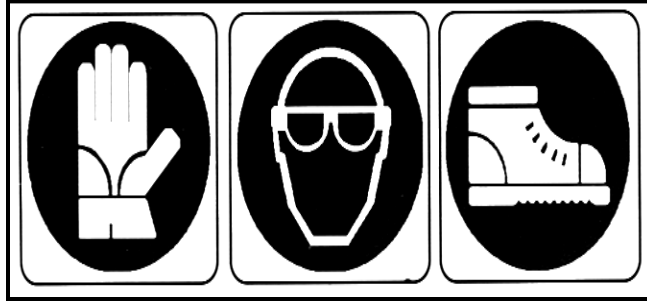

Shield Removal:

- To remove the shield, pop out the red snap, then rotate the guard on the bearing to line up the three tabs with the openings and pull it off away from the knuckle joint.
- Remove the nylon bearing from the shaft by spreading it open.



Shield Assembly:

- Be sure to lubricate the groove in the inner yokes where the shield bearing rides. Reinstall shields in the reverse order that they were removed.

Lubrication:

- Be sure to follow the lubrication timeline as outlined on page 30.
- Use low temperature grease if operating in cold temperatures. This will allow the PTO splines to slide much easier in these conditions.

Hydraulics

WARNING: *Pressurized hydraulic fluid can cause serious injury.*

- When working with hydraulic equipment, eye and hand protection should be worn.
- Do not test for leaks with bare hands.
- Relieve any pressure before removing a hose or fitting.
- Never work under components raised by hydraulic equipment unless supported externally.



There are up to four sets of hydraulic hoses to connect to the tractor, depending on the installed options. Each hose has a coloured marker to identify its function. They should be connected at best convenience for the tractor's controls. Note that the hoses are paired by colour and the following tables show the operation when pushing oil into the hose with the longer marker.

36037		5400 – 3 Remote	
	Long Blue		Lift rear fork
	Long Yellow		Lift deflector
	Long Red		Rollers rotate clockwise

An optional diverter kit is available to allow the Bale King 5400 to run using only two sets of hoses. The function is then determined by a control box, mounted in the cab of the tractor.

36229		5400 – 2 Remote	
	Control Box	“FORK”	“DEFLECTOR”
	Long Blue	Lift rear fork	Lift deflector
	Long Red	Rollers rotate clockwise	



Always set the tractor's hydraulic flow at a lower rate and adjust it upward until the desired speed is reached. Excessive oil flow may damage the flow divider cartridge.

An optional rotary straw assist (“Kicker”) kit is available to allow the Bale King 5400 to help deal with rotary straw bales which may break open and bridge the tub (see page 22). If this kit is installed, an additional function is added to the hydraulics. This changes the hydraulic setup as shown in the following table.

5400K – 2 Remote	
36232	Control Box “AUXILIARY” “FORK” “DEFLECTOR”
	Long Blue Lift kicker Lift rear fork Lift deflector
	Long Red Rollers rotate clockwise
5400K – 3 Remote	
36231	Control Box “FORK” “DEFLECTOR”
	Long Blue Lift rear fork Lift deflector
	Long Red Rollers rotate clockwise
	Long Green Lift kicker
5400K – 4 Remote	
36230	Long Blue Lift rear fork
	Long Red Rollers rotate clockwise
	Long Yellow Lift deflector
	Long Green Lift kicker

An optional 3-bale kit is available to allow the Bale King 5400 to carry an extra bale on the rear of the machine (see page 25). If this kit is installed, an additional clamp is added to the hydraulic functions. This changes the hydraulic setup as shown in the following table.

5400X – 2 Remote	
36232	Control Box “AUXILIARY” “FORK” “DEFLECTOR”
	Long Blue Open bale clamp Lift rear fork Lift deflector
	Long Red Rollers rotate clockwise
5400X – 3 Remote	
36231	Control Box “FORK” “DEFLECTOR”
	Long Blue Lift rear fork Lift deflector
	Long Red Rollers rotate clockwise
	Long Green Open bale clamp
5400X – 4 Remote	
36230	Long Blue Lift rear fork
	Long Red Rollers rotate clockwise
	Long Yellow Lift deflector
	Long Green Open bale clamp

An optional grain tank kit is available to allow the Bale King 5400 to carry 40 bushels of grain on the side of the machine (see page 24). If this kit is installed, additional motors are added to the hydraulic functions. This changes the hydraulic setup as shown below:

36232	5400TR – 2 Remote			
	Control Box	<i>“AUXILIARY”</i>	<i>“FORK”</i>	<i>“DEFLECTOR”</i>
	Long Blue	Discharge grain	Lift rear fork	Lift deflector
	Long Red	Rollers rotate clockwise		
36231	5400TR – 3 Remote			
	Control Box	<i>“FORK”</i>		<i>“DEFLECTOR”</i>
	Long Blue	Lift rear fork		Lift deflector
	Long Red	Rollers rotate clockwise		
	Long Green	Discharge grain		
36230	5400TR – 4 Remote			
	Long Blue	Lift rear fork		
	Long Red	Rollers rotate clockwise		
	Long Yellow	Lift deflector		
	Long Green	Discharge grain		

If multiple kits are installed on the machine, the hydraulic setup is as shown below:

36234	5400KX – 3 Remote			
	Control Box	<i>“AUXILIARY”</i>	<i>“FORK”</i>	<i>“DEFLECTOR”</i>
	Long Blue	Lift kicker	Lift rear fork	Lift deflector
	Long Red	Rollers rotate clockwise		
	Long Green	Open bale clamp		
36233	5400KX – 4 Remote			
	Control Box	<i>“FORK”</i>		<i>“DEFLECTOR”</i>
	Long Blue	Lift rear fork		Lift deflector
	Long Red	Rollers rotate clockwise		
	Long Yellow	Open bale clamp		
	Long Green	Lift kicker		
36234	5400XTR – 3 Remote			
	Control Box	<i>“AUXILIARY”</i>	<i>“FORK”</i>	<i>“DEFLECTOR”</i>
	Long Blue	Open bale clamp	Lift rear fork	Lift deflector
	Long Red	Rollers rotate clockwise		
	Long Green	Discharge grain		
36233	5400XTR – 4 Remote			
	Control Box	<i>“FORK”</i>		<i>“DEFLECTOR”</i>
	Long Blue	Lift rear fork		Lift deflector
	Long Red	Rollers rotate clockwise		
	Long Yellow	Open bale clamp		
	Long Green	Discharge grain		

36234	5400KTR – 3 Remote				
	Control Box	<i>“AUXILIARY”</i>	<i>“FORK”</i>	<i>“DEFLECTOR”</i>	
	Long Blue	Lift kicker	Lift rear fork	Lift deflector	
	Long Red	Rollers rotate clockwise			
	Long Green	Discharge grain			
36233	5400KTR – 4 Remote				
	Control Box	<i>“FORK”</i>	<i>“DEFLECTOR”</i>		
	Long Blue	Lift rear fork	Lift deflector		
	Long Red	Rollers rotate clockwise			
	Long Yellow	Lift kicker			
	Long Green	Discharge grain			
36236	5400KXTR – 3 Remote				
	Control Box *	<i>“KICKER”</i>	<i>“AUXILIARY”</i>	<i>“FORK”</i>	<i>“DEFLECTOR”</i>
	Long Blue	Lift kicker	Open bale clamp	Lift rear fork	Lift deflector
	Long Red	Rollers rotate clockwise			
	Long Yellow	Discharge grain			
36235	5400KXTR – 4 Remote				
	Control Box	<i>“AUXILIARY”</i>	<i>“FORK”</i>	<i>“DEFLECTOR”</i>	
	Long Blue	Lift kicker	Lift rear fork	Lift deflector	
	Long Red	Rollers rotate clockwise			
	Long Yellow	Open bale clamp			
	Long Green	Discharge grain			



* 3 Option – 3 Remote Control Box with additional push button switch

Hose Holder

The hydraulic hoses may need to be adjusted to avoid damage from rubbing on the PTO shaft. This can be done by lifting or lowering the hose holder. Loosen the pin handle, then lift the end of the hose holder to drop the pin into the slot. Then adjust the height as desired and catch the pin into the desired notch. Finally, retighten the pin handle to prevent it from switching positions if the machine bounces.

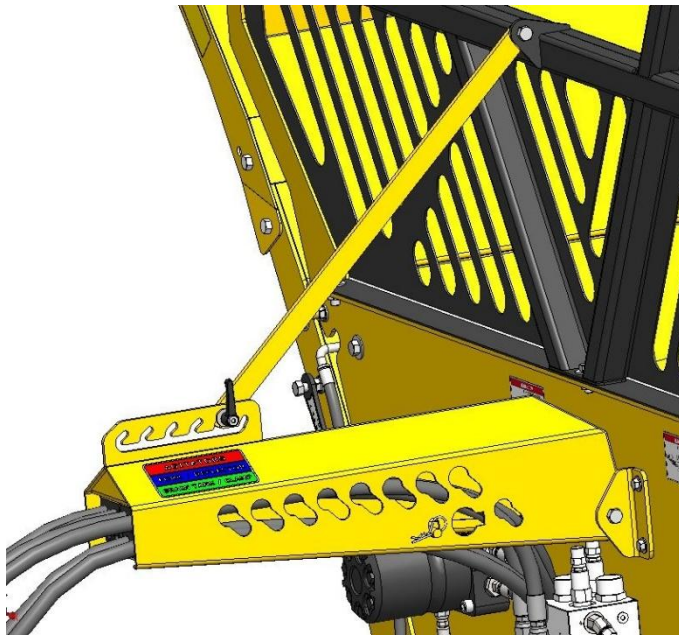

Loosen handle
Lift end of holder
Slide pin in slot
Choose setting
Tighten handle

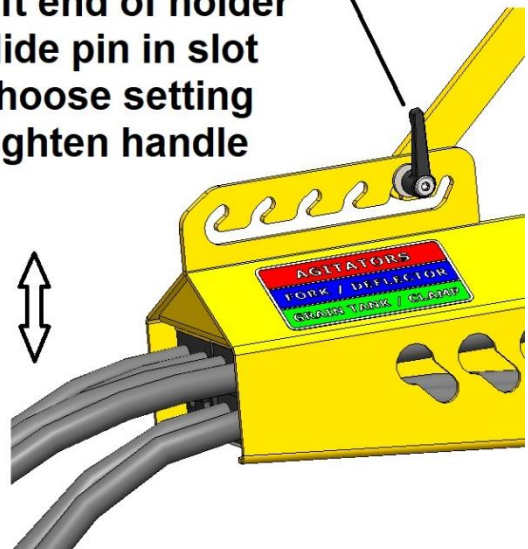

Implement Tongue

The adjustable hitch on the Bale King features a cast single tongue with optional clevis insert. This allows for use with tractors equipped with a hammer strap or with a single drawbar. It also allows the machine to move independently over rough terrain without bending the draw pin.

- Make sure that the drawbar is set to **16 inches** behind the PTO shaft for proper PTO length.
- Adjust the hitch height to match the tractor drawbar height as close as possible per the chart above. This will make the frame run level and keep the PTO as straight as possible.
- **DO NOT** install the clevis insert if using a tractor with a hammer strap as this will bend the hitch pin.
- **ALWAYS** connect the safety chain during road transport

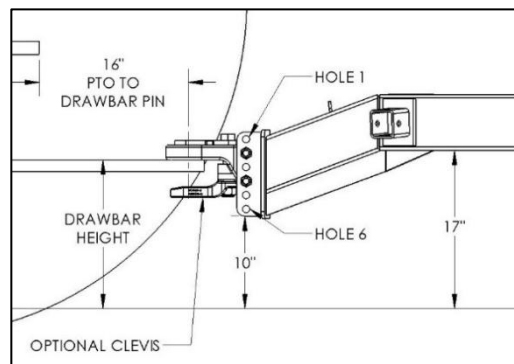

Clevis Hitch Option	BMI #29786
Drawbar Height	Holes
17.5"	1 & 3
16"	2 & 4
14.5"	3 & 5
13"	4 & 6

Rear Forks

The rear fork bale tines can be adjusted side to side by removing the pin connecting the tine to the machine and replacing the tine in the other available gap. The widest position is recommended for all situations, except for the smallest bales. Always use tines in the same position on either side to keep the load on the forks and cylinders balanced.

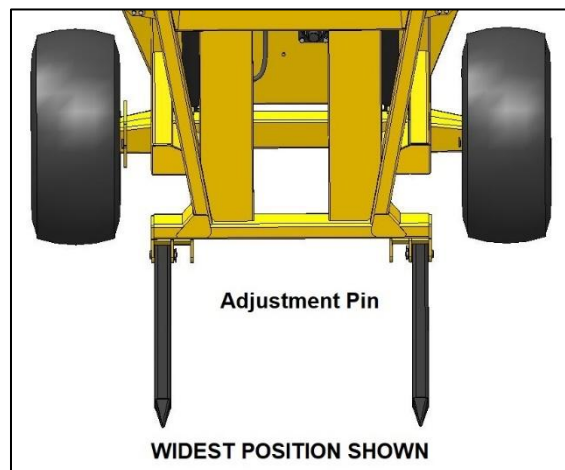

For transport, and safety when working under the forks, the Bale King 5400 is equipped with hydraulic safety valves that do not allow the forks to come down without hydraulic pressure. Lowering the forks using the tractor controls overrides this valve and allows the forks to lower. Never stand under the forks. When greasing or servicing around the rear end, the forks should be down. Never attempt to loosen or replace hydraulic hoses while the forks are up.

Loading Bales



When loading bales into your Bale King bale processor, the following procedure should be followed:

- Position the tractor and the Bale King to be lined up to back straight into the row of bales.
- When close to the bale, lower the forks completely (you will feel a light vibration as the forks bottom out against the frame.)
- Back completely under the first bale.
- Allow the tractor to move forward while lifting the bale, because the bale fork moves away from the machine while loading.
- If you are loading from the same row you can dump the bale into the machine and back straight into the second bale. If you are going to a different stack for the second bale only raise the first bale enough to clear the ground. Move to the next row and align the machine to the bale before dumping the bale into the tub. This gives you good visibility to line up to the second bale.
- Once you have the first bale in the tub and the second bale on the forks, raise the bale fork about 1/4 of the way up. You can now transport to your feeding or bedding area to begin processing.

Note: *Carry the bale as low as possible to lessen the stress on the cylinder shafts. Carrying the bale too high may bend hydraulic cylinder shafts.*

- When the first bale has been processed, it is common practice to leave the rotor running at full speed when loading the second bale into the bale chamber from the rear forks. However, the rollers should be stopped during loading.

For information on the optional 3-bale kit, see page 25.

Setting the Processor

Processing speed must be balanced with overall aggression and vibration levels. Excessive continuous vibration may affect the service life of the processor. Processing times of 1-2 minutes are considered normal in dry bale conditions. Extended times are expected in tougher conditions such as high moisture feed, frozen, or misshapen bales. The processor may need to be adjusted for each type of bale for optimal performance. ***Processing a bale too rapidly may cause excessive vibration and driveline damage.***

There are 3 main components to setting the processor:

1. **Hoop grate height:** Adjusts how far the flails protrude above the grate
2. **Bale roller speed:** Adjusts the feed rate to the rotor
3. **Bale rotation direction:** Controls the feed direction over the rotor

Hoop Grate Adjustment

There are eight adjustment settings for the hoop grate on the bale processor. These settings vary the aggression and length of cut. To adjust, pull the spring handle outward, then swing the handle “UP” for a more aggressive cut, or “DOWN” for less aggression. Then release the spring handle to engage the pin in the desired hole.

When there is a bale in the tub, the bale's weight will be placed on the hoop grates, making adjustment more difficult. Adjust the machine when it is empty when possible.

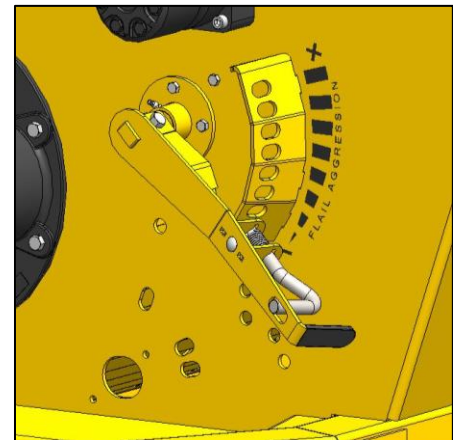

- **Position #1 (Bottom):** Highest grate setting for finest cut and slowest rate of feed. Used for tough processing feeds such as silage bales, or other wet materials.
- **Position #2-6:** Normal operating range. Machine gets more aggressive as handle moves “up”.
- **Position #7-8 (Top):** Lowest grate positions, most aggressive, fastest rate of feed.

The Bale King should be adjusted according to bale conditions to achieve a rate of feed of approximately **1 to 2 minutes**. Light, brittle material such as wheat straw may allow faster processing while tough stringy material such as silage, slough hay, green feed, or flax will require slower processing. Hoop grate adjustment should be checked periodically.

NOTE: *Upper grate position should be approximately 0" flail protrusion. Lower grate position should allow 3" flail protrusion.*

Bale Roller Speed

The Bale King is equipped with a flow divider/combiner and two hydraulic motors for turning the bale. Proper roller speed is critical to smooth processing. Roller speed is adjusted via your tractor's flow control. Set a one-minute timer and count revolutions of a roller paddle. 40 RPM is a typical starting point. Speeds of 30 to 45 RPM are considered normal depending on bale conditions.

If vibration is excessive, slow the rollers and raise the hoops as necessary to adjust. Excessive roller speed will overload the processor and potentially cause the shear bolt to break. Extended periods of overload may cause driveline damage. Excessive roller speed will also increase loose material build-up on the non-discharge side of the processor. Proper roller speed balances the feed inflow to the rotor with its discharge rate.

Rotation Direction

Turn the bale counter-clockwise (as viewed from the tractor seat) as much as possible. Reverse only as necessary to clear loose material. When turning counter-clockwise, feed flows over the hoop grate, through the rotor, and out the discharge area. When turning clockwise, material is fed both over the rotor and over the non-discharge bale roller into the rotor. This can cause overloading and vibration.

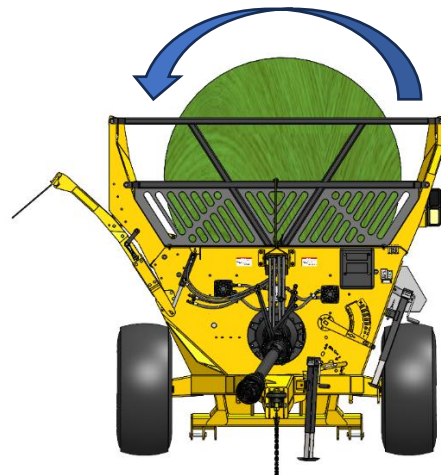

Deflector

The Bale King 5400 is equipped with a hydraulic side deflector to change the discharge distance and distribution. It also comes with a flipping rubber flap for superior control of the spread pattern.

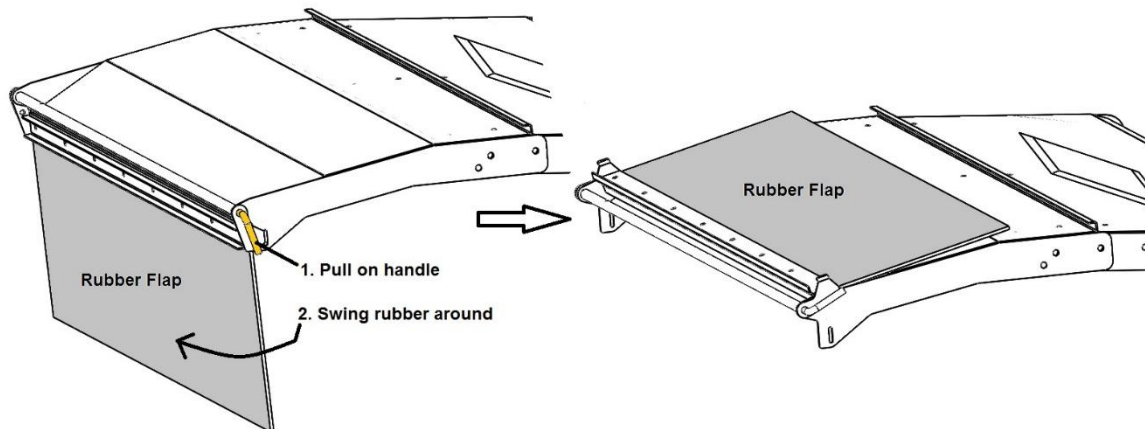

Moving the deflector to the **down** position and flipping the rubber down (above left) will allow the hay to be laid in a windrow, or bunk feeder. Swinging the deflector **up** will allow you to spread straw out over a large area. If you also flip the rubber up (above right), you will be able to "fine tune" the discharge, to control the height and distance.

To flip the rubber, simply pull on the handle and swing into position. Then push the handle so that the tabs catch in the notches and lock into place.

The Bale King 5400 deflector will bunk feed to a distance of 32" from the tire when in the lowest position. When the deflector is not folded, the transport width of the machine is 10'.

For transport and storage, the deflector lock should be put in place by swinging the lock as shown and fastening with a lynch pin.



The Bale King 5400 deflector also has the ability to fold for more compact long-term storage or long-distance transport.

- Move the deflector to its lowest position
- Remove the 7 top carriage bolts from the deflector.
- Loosen all the 4 bolts on the front and back of the deflector.
- Raise the deflector to its highest position with the hydraulics. Remove the bolts closest to the machine center (both front and back) and swing the outer deflector down.

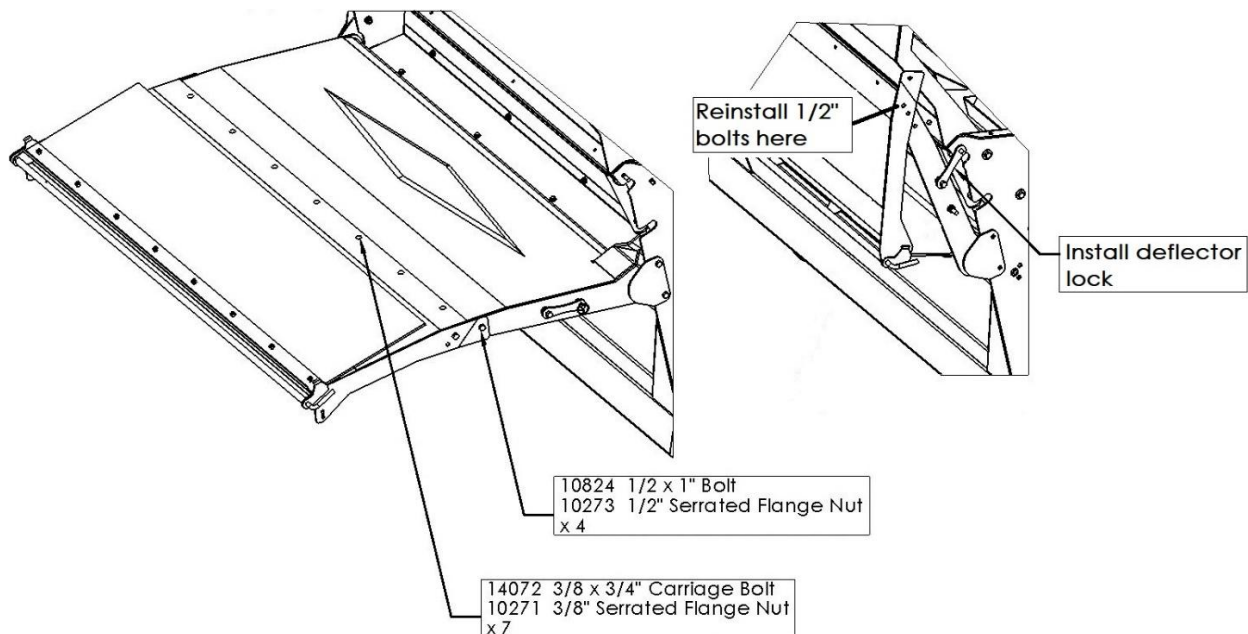

BE CAREFUL WHEN LIFTING THE DEFLECTOR WITH THE OUTER PANEL ABLE TO PIVOT TO AVOID CONTACTING THE TIRES.

Optional Diverter Kit

5400	2-Remote Option	BMI #36229
------	-----------------	------------

The Bale King 5400 processor has an optional diverter kit which allows it to operate using only 2 hydraulic remotes. The fork and deflector functions are then controlled by a cab-mounted switch box. This box must be wired up to the tractor's electrical system. You may use the provided plug to plug into the accessory outlet. If this is not available, the plug can be disassembled, and wired as necessary.

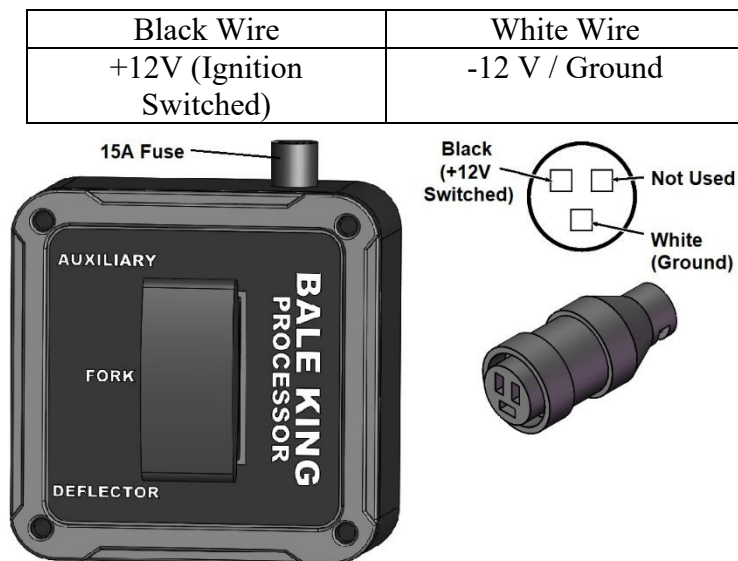

	5400	1 Option	2 Option	3 Option
Diverter Kit (4 Remote)	n/a	36230	36233*	36235*
Diverter Kit (3 Remote)	36037	36231*	36234*	36236*
Diverter Kit (2 Remote)	36229*	36232*	n/a	n/a

* These kits require a control box.

If changing from one package to another, contact Bridgeview to obtain an adaptor kit

A 4-pin plug is used to power the diverter valve on the processor. If no power is supplied, the hydraulics will still control the rear forks, but the deflector will not be functional. If the switch in the tractor is activated, the deflector can be controlled. On 5400 machines with an optional “TR” Grain Tank or “X” Three Bale Kit, this box can also control grain flow or the 3 Bale Clamp (as “Auxiliary”).

The diverter kit also features a pilot operated check valve to ensure that the deflector will not fall down due to leaking across the valve.

Optional Rotary Straw Assist “Kicker” Kit

5400	Rotary Straw Assist Kit	BMI #36193
------	-------------------------	------------

Certain types of short, dry straw, typically baled behind a rotary combine, can be difficult to process. The bales expand once the net wrap is cut and may bridge over top of the bale rollers. The rotary straw assist kit may be installed at any time to aid rotation of these bales. If the rollers lose traction, raise the “Kicker Bar” fully to lift a portion of the bale up to create space in the processing tub. Process the bale, then lower the assist forks to clear the remaining portion.

This kit is intended to assist with loose outer wraps of straw only. It is NOT intended for solid material, silage, or lifting full size solid bales. It is also not for pushing material into the rotor. A relief valve is installed to limit the down pressure for this reason.

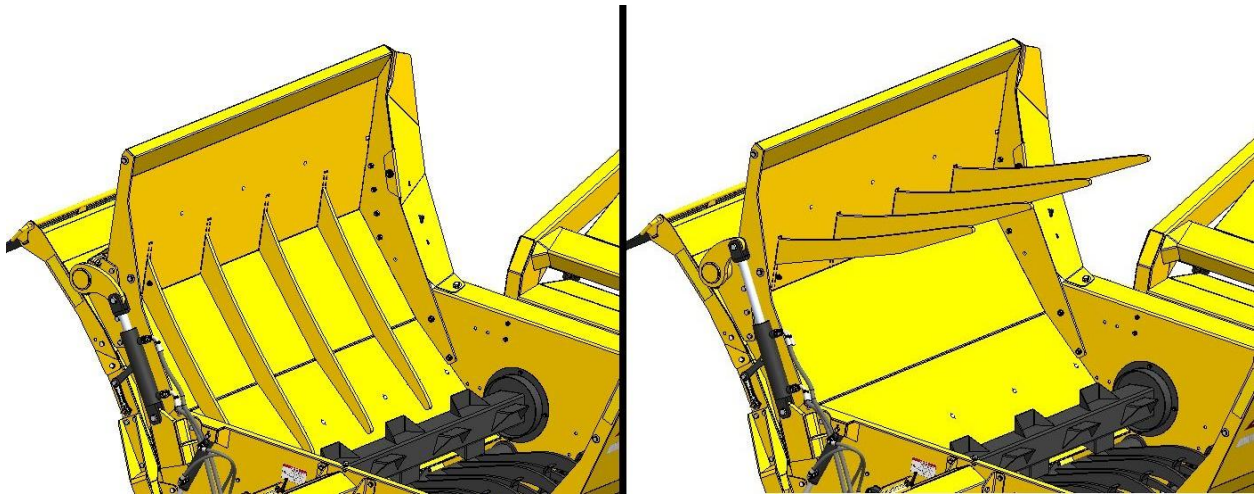

Contact Bridgeview for inquiries about adding this kit to an existing machine.

Optional Fine Chop Kit

5400	Fine Chop Option	BMI #36155
-------------	-------------------------	-------------------

The Bale King 5400 processor has an optional fine chop knife kit available to install into the lower tub area. This option is available if you desire a finer cut on the material which you are processing such as slough hay and silage bales.

It is recommended that the knives be disengaged when bedding straw as it will affect your spread pattern. Adjust the machine as needed.

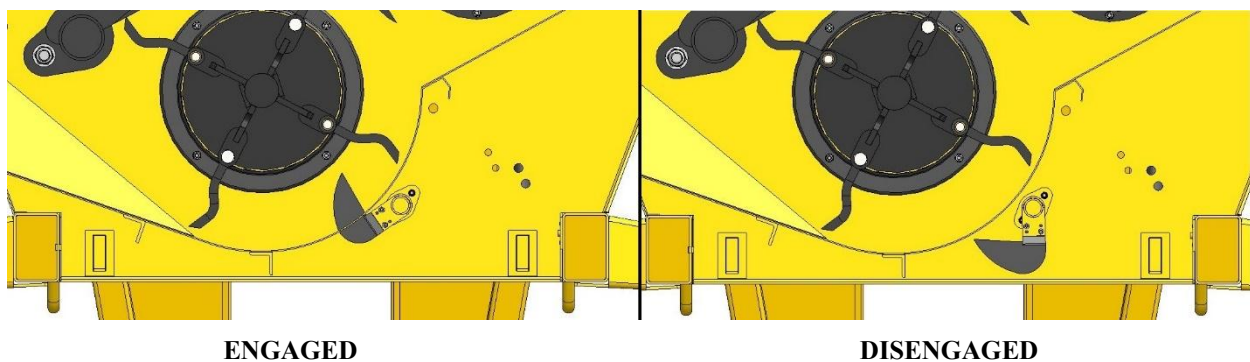

There are two settings for the fine chop, depending on how fine you wish to cut the material. These settings can be achieved by pulling out the handle, then selecting the desired hole.

0	Disengaged
1	Partially Engaged
2	Fully Engaged

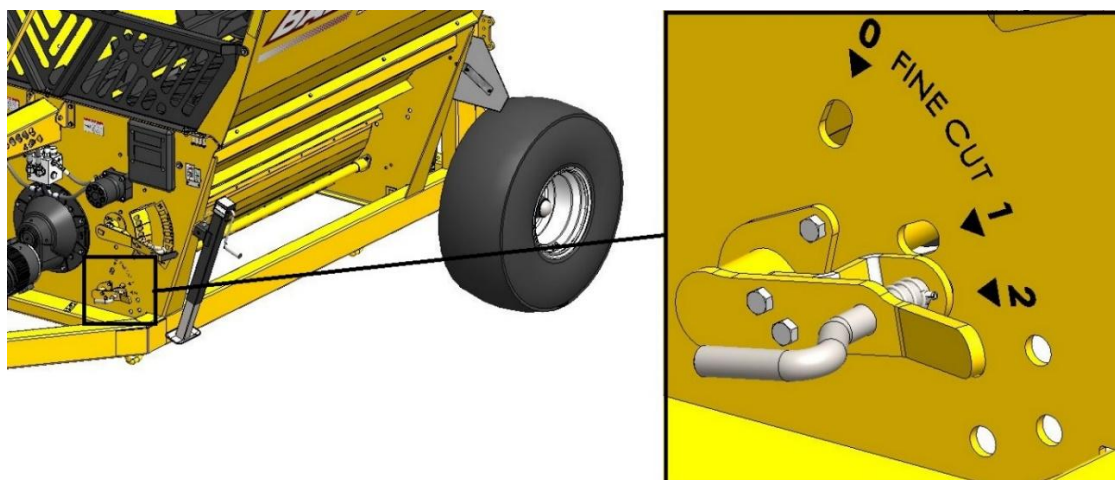

Contact Bridgeview for inquiries about adding this kit to an existing machine.

Optional Total Ration Grain Tank (5400TR)

5400	Total Ration Grain Tank Option	BMI #36242
------	--------------------------------	------------



The Bale King 5400 has an available 40-bushel grain tank, which allows grain to be discharged on top of a windrow of processed hay, or independently out the right side of the machine. This bolt-on kit changes the processor to a 5400TR (Total Ration).

The tank is located on the left side of the machine and features a large opening, 5 ft off the ground for easy filling. A flow control valve allows you to adjust the speed of the augers so that you can meter the grain flow for different situations. It is recommended to determine your desired rate based on driving speed and the flow rate of the tractor. Setting the valve to "0" will give no grain, while setting it to "10" will be full speed.

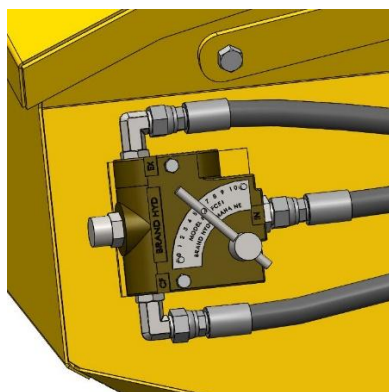

Cleanout doors are located at the bottom end of both the cross-auger, and the grain tank. It is recommended that both be cleaned out at the end of every season.

Contact Bridgeview for inquiries about adding this kit to an existing machine.

Optional 3 Bale Kit (5400X)

5400	3 Bale Kit Option	BMI #36139
------	-------------------	------------



The Bale King 5400 has an available attachment kit which increases the carrying capacity of the processor by 50%, while maintaining the easy maneuverability of the two-bale processor. The attachment kit stores the second loaded bale behind the first and above the third in a set of powerful hydraulic clamps.

The 3 Bale Kit changes the loading process of the bale processor slightly. The loading of the second bale involves lifting the bale so the fork and bale are parallel to the ground, or just above this point. The clamp will be closed around the bale at this point and the fork can be lowered back to the ground. The third bale can then be backed under and lifted until it is lightly supporting the second bale. After the first bale processing is complete, the clamp can be opened (while the third bale is supporting the second), and the fork can be lifted until the third bale pushes the second into the tub.

An optional back-up camera (pg. 29) is available to aid in the loading process by giving the operator direct visibility of the loading forks, even with a bale in the tub. See the next section for more information about loading.

Contact Bridgeview for inquiries about adding this kit to an existing machine.

3 Bale Kit Loading Sequence:

1. Position the tractor and the Bale King to be lined up to back straight into the row of bales.
2. Ensure the bale clamp is opened fully.
3. When close to the bale, lower the forks completely (you will feel a light vibration as the forks bottom out against the frame).
4. Back completely under the first bale.
5. Lift the first bale, allowing the tractor to roll forward slightly while lifting the bale. This is because the lifting fork moves away from the machine slightly when loading.
6. If you are loading from the same row, you can dump the bale into the machine and back straight into the second bale. If you are going to a different stack for the second bale, only raise the first bale enough to clear the ground. Move to the next row and align the machine to the bale before dumping the bale into the tub. This gives you good visibility to line up to the second bale.
7. Once you have the first bale in the tub and the second bale on the forks, raise the second bale until it presses on the bale in the tub and then lower it until the fork is approximately horizontal or just above. Raising and then lowering the bale puts it in the optimal position for clamping and clearance on the bottom bale.



8. Once the bale is in the appropriate location, close the clamp fully and then lower the lifting fork.



9. Back under the third bale and lift the forks until the third bale is lightly supporting the second bale. You will see when to stop lifting as the clamped bale will tilt forward slightly.



10. When the first bale has been processed and the third bale is still lightly supporting the second, open the clamp to release the second bale. Once the clamp is opened, lift the fork until the third bale pushes the second bale into the tub.



11. Once the second bale is processed, the fork can be fully lifted to load the third bale into the tub.



Lockout Mechanism Adjustment and Setting

The 3 Bale Kit is equipped with a lockout mechanism that prevents damage to the clamps if the fork is lifted before the clamps are released. The lockout mechanism works by allowing the clamps to “break-away” if contacted, or if a bale in the fork pushes too hard on a clamped bale. When this happens, a valve is activated which locks out the forks and prevents them from lifting any higher. To reset, lower the bale slightly to release the valve, then open the clamps.



Clamps lift up in slot, activating the valve. Lowering the forks resets this.

Optional Back-up Camera

5400	Standard Kit (down to -20°C)	BMI #32619
5400	Pro Kit (down to -40°C)	BMI #32628

The Bale King 5400 processor has an optional back-up camera to provide increased visibility while loading bales. This is especially helpful when combined with a 3-bale kit.



The kit includes a mounting bracket to install the camera on the rear axle of the processor, as well as cables to run to the tractor. The monitor can be installed in the tractor cab, with a plug between the tractor and processor.

SERVICE AND MAINTENANCE

Greasing Locations

Lubricating the Bale King bale processor should be done on a regular basis.

Every 50 bales			
A	Rotor Gearbox	1	3-5 pumps
Every 150 bales			
B	Bale Fork Pivot	2	3-5 pumps
C	3-Bale Kit Arm Pivot *	2	3-5 pumps
D	Hoop Handle	1	3-5 pumps
E	Deflector	1	3-5 pumps
F	Rotary Straw Kicker Bar *	2	3-5 pumps
PTO	PTO Cross & Bearings	4	5 pumps
	PTO Guard Bushings	2	5 pumps
	PTO Spline	1	8-10 pumps
Every 500 bales (or Annually)			
PTO	PTO CV Joint	1	30 pumps
G	Roller Bearings	2	3-5 pumps (DO NOT OVERGREASE)
H	Rotor Bearing	1	3-5 pumps (DO NOT OVERGREASE)
I	3-Bale Kit Swivel Eye *	2	3-5 pumps
J	Jack	1	8 – 10 pumps
Annually			
K	Wheel Hubs	2	Pack hubs full

* IF EQUIPPED

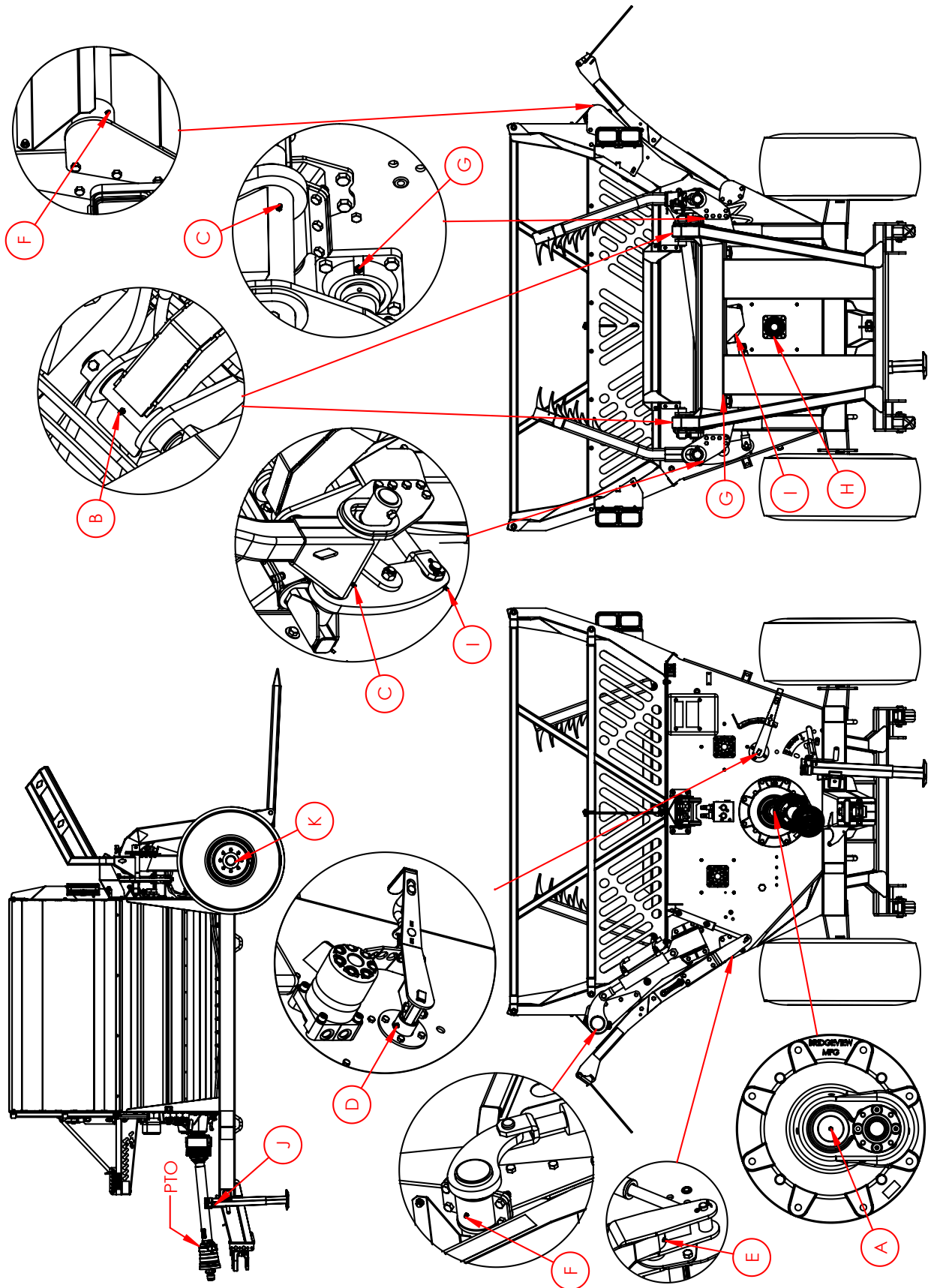

PTO/Driveline

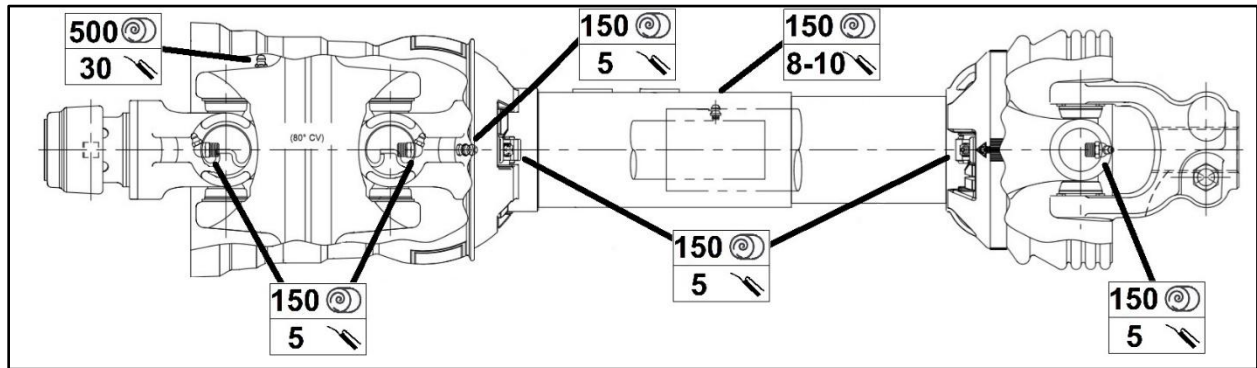

After storage for long periods of time, lubricate and check the function of every driveline component before operating. Failure to grease all the joints will **VOID** warranty.

All zerks can be accessed while the PTO is connected to the tractor EXCEPT for the telescoping spline, which can only be accessed when the PTO is fully retracted.

If operating in very cold temperatures (below -20°C or -5°F), low temperature grease (ex. EP-1 synthetic) should be used, especially where the splines overlap. This will make extending / retracting the shaft much easier and relieve stress from turning.

Gearbox

There is one grease zerk on the front of the gear box. Apply 3-5 pumps of good quality grease every 150 bales.

If the gearbox is removed to replace the rotor or perform any other service, add **80 pumps** of grease to the grease zerk upon reinstallation.

The gear box requires GL5 80W90 gear oil. The oil should be filled to the level plug (approximately **500 mL**) and checked on a regular basis. The oil should also be changed at the following intervals:

- 250 bales after first use
- Every 2000 bales afterwards, or annually (whichever comes first)

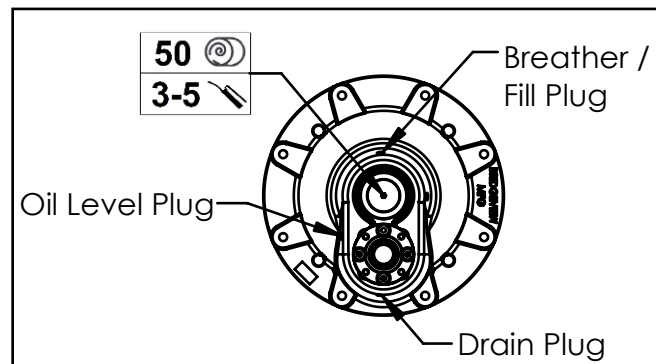

Cylinder Maintenance

The hydraulic cylinders are easily removed for repair or maintenance simply by:

- Lowering the fork (or deflector) to the down position and unhooking the hydraulic lines. Be sure there is no pressure on the lines and mark the line locations so there is no confusion when reinstalling the cylinders. Check hydraulic schematics.
- Removing the cotter pin closest to the frame of the machine and sliding the cylinder pins out
- To reinstall, reverse the removal procedure

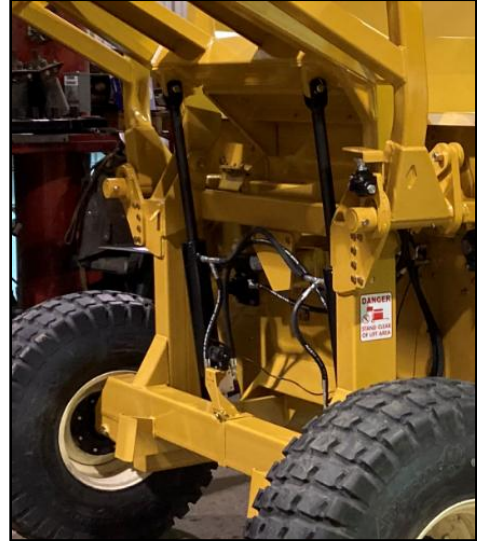

NOTE: *Always cover exposed cylinder shafts with grease to avoid rusting of shafts if the unit is not used for extended periods of time. Rusted cylinder shafts are NOT covered by warranty*

NOTE: *Check all hoses and fittings periodically for leaks. Tighten or replace any dripping components or any worn out hoses.*

Tires

Wheel bearings should be inspected annually for adjustment and lubricated annually. Inspect more often for extensive traveling.

- To tighten the wheel bearings, lift each wheel (one at a time) until the wheel spins freely.
- Remove dust cap and the cotter pin which retains the castle nut.
- Tighten the nut until the wheel will rotate approximately two turns when given a firm spin.
- Align castle nut to closest hole and insert the cotter pin.
- Pack hub full of grease and reinstall the dust cap.

Proper tire inflation will help to alleviate puncture problems when towing and operating on rough terrain.

Check for proper tire inflation	24 psi
Replace any damaged or worn tires	16Lx16.1 12-ply
Check and tighten wheel bolts on a regular basis	125 ft.lb

Note: Warranty does not cover damaged rims and hubs due to loose wheel bolts or flat tires.

Tire warranty is covered by the tire manufacturer.



Note: When inflating tires, use a clip-on chuck and extension hose long enough to allow you to stand to one side and NOT in front of or over the tire assembly.

Twine Removal

It is natural that twine from the bales will wrap around the rotor as they are being processed. It is recommended to remove the twine from the rotor every 10-15 bales to avoid having so much that it begins to hinder the flail movement. The more often this is done, the easier it is to remove, since the twine has not had a chance to wrap more tightly. The patented “X” shape makes twine removal much easier.

WARNING: Before attempting the removal of twine from the rotor, be sure that the machine is stopped and the tractor is shut **OFF**. Place the tractor in park. Twines can be removed with the use of the optional knife, or any other knife.

An electric device is also available from suppliers to melt the twine & allow it to be pulled off. Once melted, the twine should be removed immediately to prevent damage to the rotor. It is **NOT PERMITTED** to leave the twine burning on the rotor as this has several adverse effects:

- It may take the temper out of the steel, rendering it weaker.
- Loose straw and hay remaining in the machine may ignite causing a fire in the processor.
- Excessive buildup of melted plastic.
- Damage bushings causing them to wear prematurely.

NOTE: *Bridgeview Manufacturing Inc. VOIDS warranty for any damage caused by twine burning in the processor.*



Twine guards are installed on the machine to keep bale twine out of important areas such as bearings.

- The wheel hubs have a twine guard to keep anything from getting tangled in the wheel bearing. Check for and remove any twine which may have wrapped around the spindle.
- The main rotor and the rollers are equipped with removable twine guards. The guards are mounted to the inside of the front and rear walls of the machine. The twine guards are bolted and need to be removed if you need to access the bolts on the bearings or the hydraulic motors.
- Remove any twine which may have wrapped around the rollers.

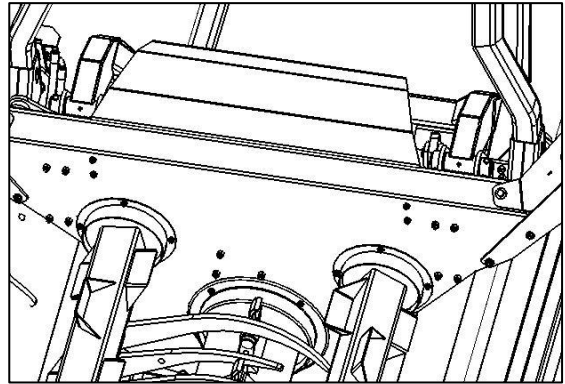
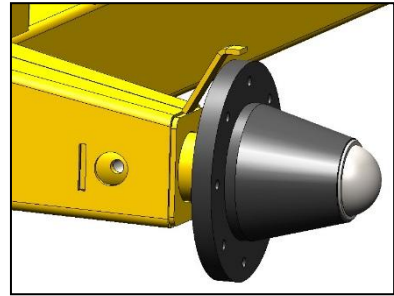

Gearbox and Flail Replacement Procedure

Flail replacement is accomplished by removing the 3/4"x 4-1/8" carriage bolt holding the flail to the rotor. The flail is then lifted away from the rotor. The bushing can now slide out from the flail bushing. Inspect the bolt, bushing, and the flail for wear. If wear is excessive, replace with new parts.

Flail	35732
Bushing	35730

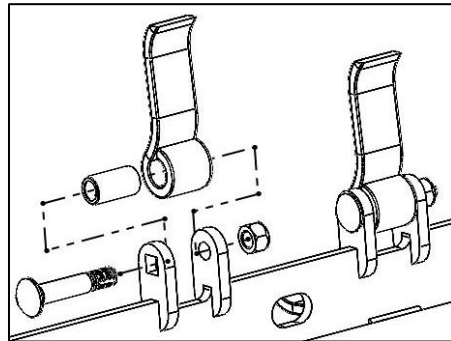

Bridgeview Manufacturing Inc. recommends when changing flails to change in **PAIRS** (opposite each other). Processing bales with broken flails causes the rotor to be out of balance and excessive vibration may cause machine deterioration.

If a new rotor is required, use the following procedure:

- Clean the spline and shaft ends of the rotor of any debris
- Clean the inside of the gearbox. Check the splines for damage.
- Remove the hoops. Use the provided lift holes to lower the pipe end, then swing the end of the tines up past the non-discharge roller and finally lift upward. Removing the rollers is not required.
- Remove rear twine guard and slide loosely over the rotor.
- Attach a lift sling to the rotor. Use the hole slightly to the rear of center. Lift just until the slack is out of the strap.
- Remove the gearbox.
- Pull the rotor out the front until it is disengaged from the bearing, then lift up and out on an angle. The rear will lift up until the front can be pushed back through the hole.
- Install new rotor bearing (if necessary). Torque to **200 ft-lb**
- Reinstall new rotor in the opposite manner of removal. Make sure the rear twine guard is slid over the rotor.
- Slide the rotor through the rear bearing. Do not tighten collar yet
- Install the gearbox over the rotor spline and bolt to the tub
- Remove the lift strap from the rotor and check that it spins freely. Check flail clearance of **1/2 to 5/8"** to tub panel.
- Center the rotor in the tub so that the flails are centered between the hoops and slots
- Tighten bearing lock collar **counter-clockwise**. Apply *loc-tite* to the set screw and torque to **100 in-lb**.
- Check gearbox oil to the side plug level (~500 mL). Replace if necessary.
- Add **80 pumps** of grease to the front gearbox grease zerk.
- Install rear twine guard using 3/8" bolts.
- Reinstall hoops

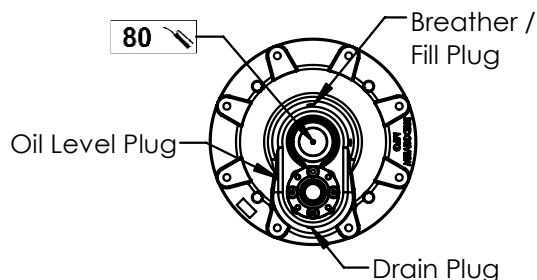
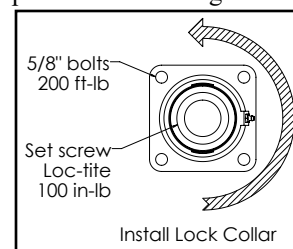

Trouble-shooting Guide

Problem	Possible Cause	Remedy
Excessive vibration while processing bales	Overloading rotor	<ul style="list-style-type: none"> • Set hoops to less aggressive position • Slow rotation of bale • Change direction of bale rotation (counter clockwise as much as possible)
	Operating machine at less than 1000 PTO RPM	<ul style="list-style-type: none"> • Operate machine at rated 1000 PTO RPM
	Broken flails causing rotor to be out of balance	<ul style="list-style-type: none"> • Replace broken flails (in pairs opposite each other)
	Excessive twine wrapped on rotor causing flail movement to be restricted	<ul style="list-style-type: none"> • Cut twine off rotor
	Rotor bearing failure	<ul style="list-style-type: none"> • Replace failed parts
Excessive shear bolt breakage	High machine vibration	<ul style="list-style-type: none"> • See above
	Engaging PTO at high engine speed or too quickly	<ul style="list-style-type: none"> • Idle tractor to engage PTO then bring up to full operating speed • Feather PTO lever into position
	Excessive horsepower	<ul style="list-style-type: none"> • Use smaller tractor (Max 150 HP)
	Incorrect shear bolt used	<ul style="list-style-type: none"> • Use correct shear bolt
Bale not turning	Excessive loose material in tub causing roller to jam	<ul style="list-style-type: none"> • Reverse direction of bale rotation to clean out • Turn bale more slowly
	Rotary straw bale bridging across rollers	<ul style="list-style-type: none"> • Install rotary straw assist kit
	Second bale interfering	<ul style="list-style-type: none"> • Lower fork slightly
	Tractor relief pressure set too low	<ul style="list-style-type: none"> • Set tractor relief pressure to at least 2500 PSI
A single roller stopping	Mechanical flow divider valve not functioning correctly	<ul style="list-style-type: none"> • Contact your dealer for repairs
	Coupler between motor and roller broken	<ul style="list-style-type: none"> • Replace failed parts
No grain Flow (Total Ration only)	Flow control valve set too low	<ul style="list-style-type: none"> • Increase flow rate in tractor or on flow control valve
	Flow control valve relief pressure set too low	<ul style="list-style-type: none"> • Use hydraulic pressure gauge to ensure relief pressure is set to 2200psi. • Ensure sufficient pressure from tractor
	Auger chute at too shallow of an angle for grain to clear fast enough	<ul style="list-style-type: none"> • Run auger slower • Run chute at steeper angle
Fork not Lifting	Lifting on the 3 bale arms trips a shutoff valve	<ul style="list-style-type: none"> • Lower fork slightly. Open 3 Bale Kit fully before lifting into tub
Kicker not Lowering	Flow going across relief valve	<ul style="list-style-type: none"> • Lift kicker and clear material below with the rollers, then lower the kicker

Features and Specifications

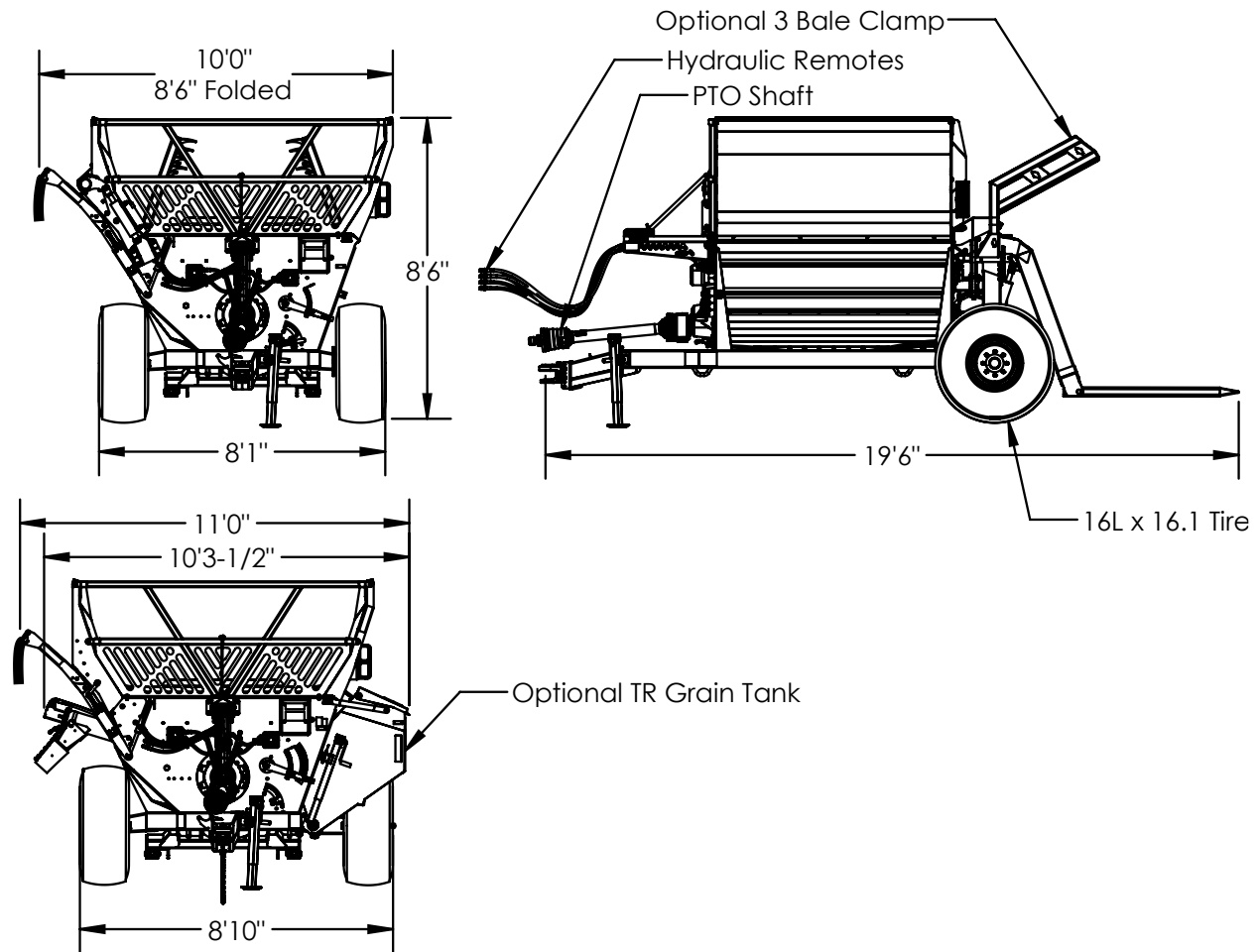

Available Options:	
Total Ration Grain Tank (40 bushel)	36242
Three Bale Kit	36139
Rotary Straw Assist Kit	36193
Fine Chop Kit	36155
Hitch Clevis	29786
Backup Camera Kit (Standard)	32619
Backup Camera Kit (Pro)	32628
Scale Kit	34754
2 Remote Hydraulic Kit	36229

Dimensions:	5400	5400TR	5400X	5400XTR
Overall Weight	4770 lb	5600 lb	5100 lb	5900 lb
Drawbar Weight	1475 lb	1650 lb	1475 lb	1650 lb
Overall Length (Forks Up)			16'-6"	
Overall Width (Deflector Down)	11'-4"	12'-3"	11'-4"	12'-3"
Grain Tank Capacity		40 bushels		40 bushels
Rotor Extended Tip Diameter			27 in.	
Discharge Opening			16 x 80 in.	

Wheels:

Tire Size	16L x 16.1 12-ply
Tire Inflation	24 psi
Wheel Nut Torque	125 ft-lb

Driveline:

Minimum Horsepower	100 HP
Maximum Horsepower	150 HP
PTO Shaft	Weasler: Cat. 6 80 deg. C.V.
Shear Bolt	3/8 x 2" Fine Thread Gr. 5
Rated PTO RPM	1000 RPM
Flail Tip Speed at 1000 RPM	7000 FPM
Number of Flails	28
Flail Size	7/16 x 2 x 6-1/4" Spring Steel
Flail Bushing	Hardened Steel
Rotor Shaft	1-15/16" Bearing
Gearbox Oil	GL5 80W90
Gearbox Oil Capacity	500 mL

Hydraulics:

Required Remotes	3 Standard 2 or 4 Optional
Minimum Flow Requirements	15 GPM
Minimum Pressure Requirements	1800 psi

Other:

Roller Shaft	1-3/4" Bearings
Twine Guards	Rotor, Rollers, Axles
Adjustable Bale Fork Width (on centers)	48 in. or 40.5 in.
Adjustable Hitch Height	4 settings at 1.5 in. intervals (13" -17.5")

PARTS MANUAL

Machine Overview	42
Jack & Hitch	43
Wheels & Hub.....	44
Hub & Spindle	45
Rotor & Drive Components	46
Gearbox.....	47
PTO Shaft.....	49
Grates	50
Rollers	52
Wings & Front Rack	53
Rear Wings & Lights	54
Lights & Harness	55
Rear Forks.....	56
Deflector & Hose Cover	57
Front Tub Components	59
Hose Holder	61
Hose Clamps	62
Diverter Control Box	64
Decals.....	68
Slow Moving Vehicle (SMV) Sign Kit	73
Three Bale Kit Option.....	74
Three Bale Kit Left Arm.....	74
Three Bale Kit Center	75
Three Bale Kit Right Arm.....	76
Total Ration Grain Tank Option.....	78
Total Ration Tank Front.....	78
Total Ration Tank Rear.....	80
Total Ration Cross Auger	82
Total Ration Tank Lid.....	84
Fine Chop Option.....	85
Optional Rotary Straw Assist “Kicker” Kit	87
Back-up Camera Option	89
HYDRAULIC SCHEMATICS.....	90

Machine Overview

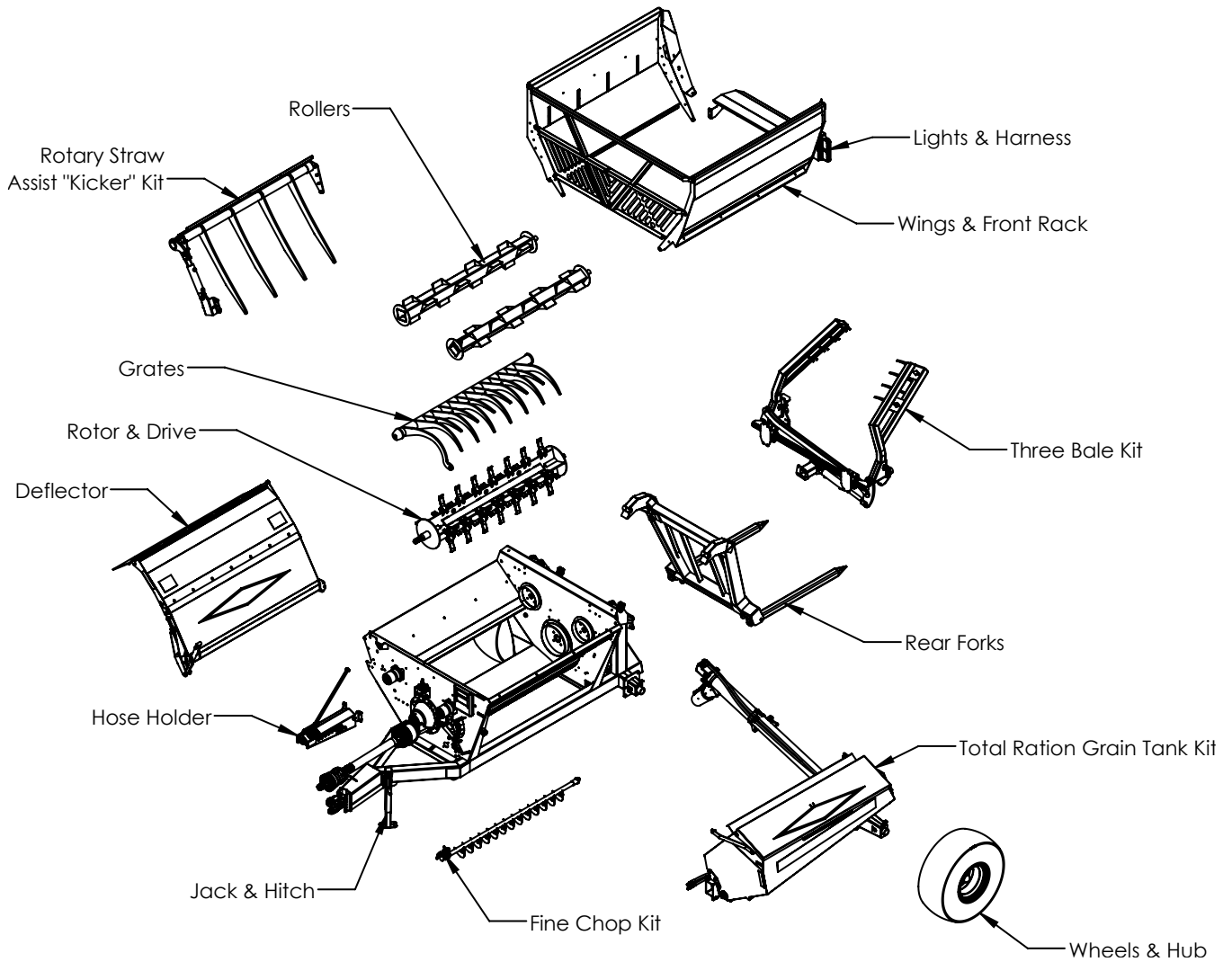

**** CHECK YOUR SERIAL NUMBER BEFORE ORDERING PARTS ****
**** PAY ATTENTION TO SERIAL NUMBER SPLITS WHERE INDICATED ****

Per Quantities: A/R = As Required
Per ID#: NSS = Not Sold Separately

Jack & Hitch

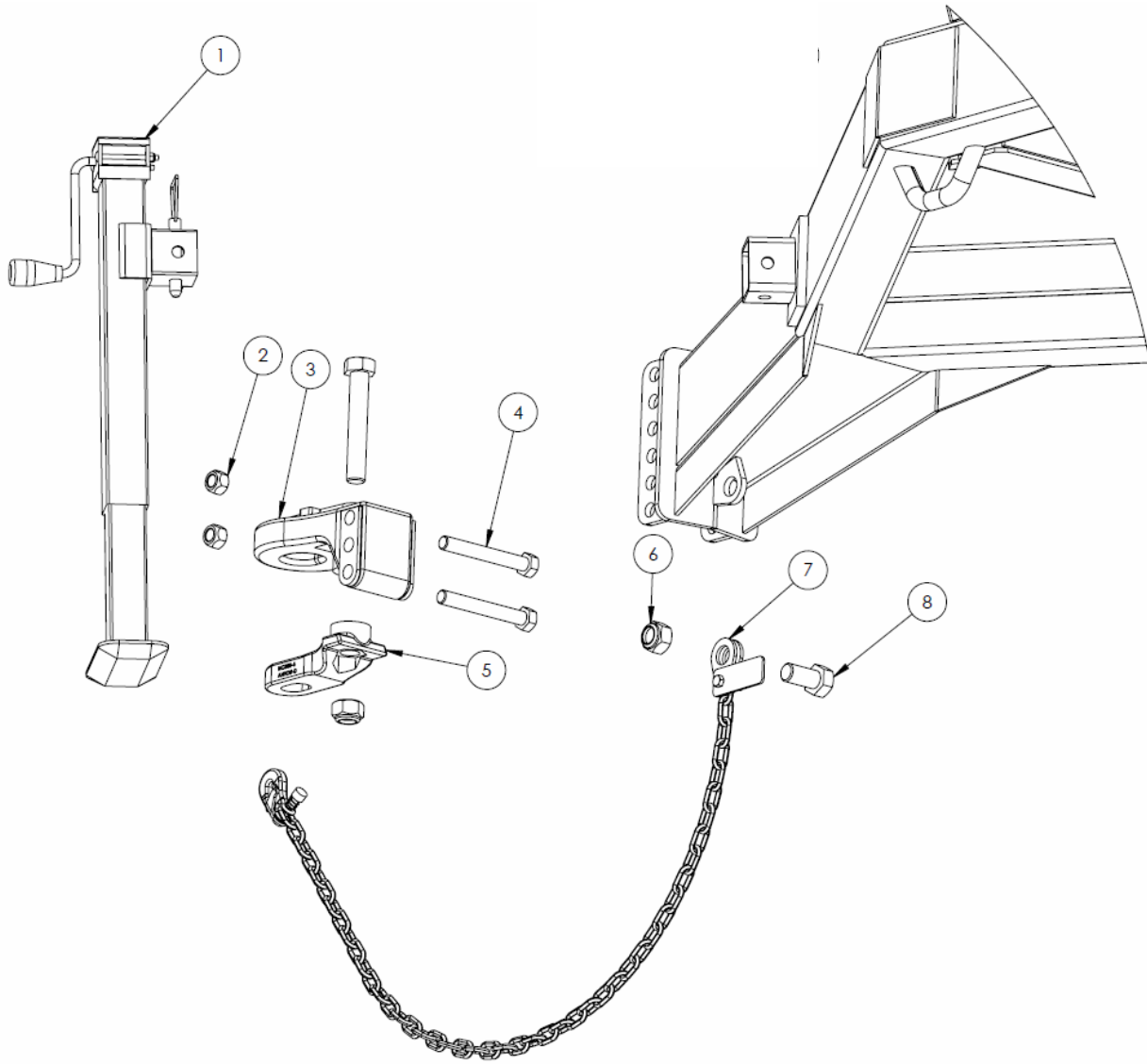

#	DESCRIPTION	PART #	QTY
1	Jack, 5000 lb Comes with pin	31637	1
2	Nut, 3/4" Stover Lock	11823	2
3	Hitch Tongue	29785	1
4	Bolt, 3/4" x 5-3/4"	10802	2
5	Hitch Clevis Kit Individual parts NSS	29786	1
6	Nut, 1" Stover Lock	21746	1
7	Safety Chain, 11000lb x 53"	21715	1
8	Bolt, 1" x 2"	18992	1

Wheels & Hub

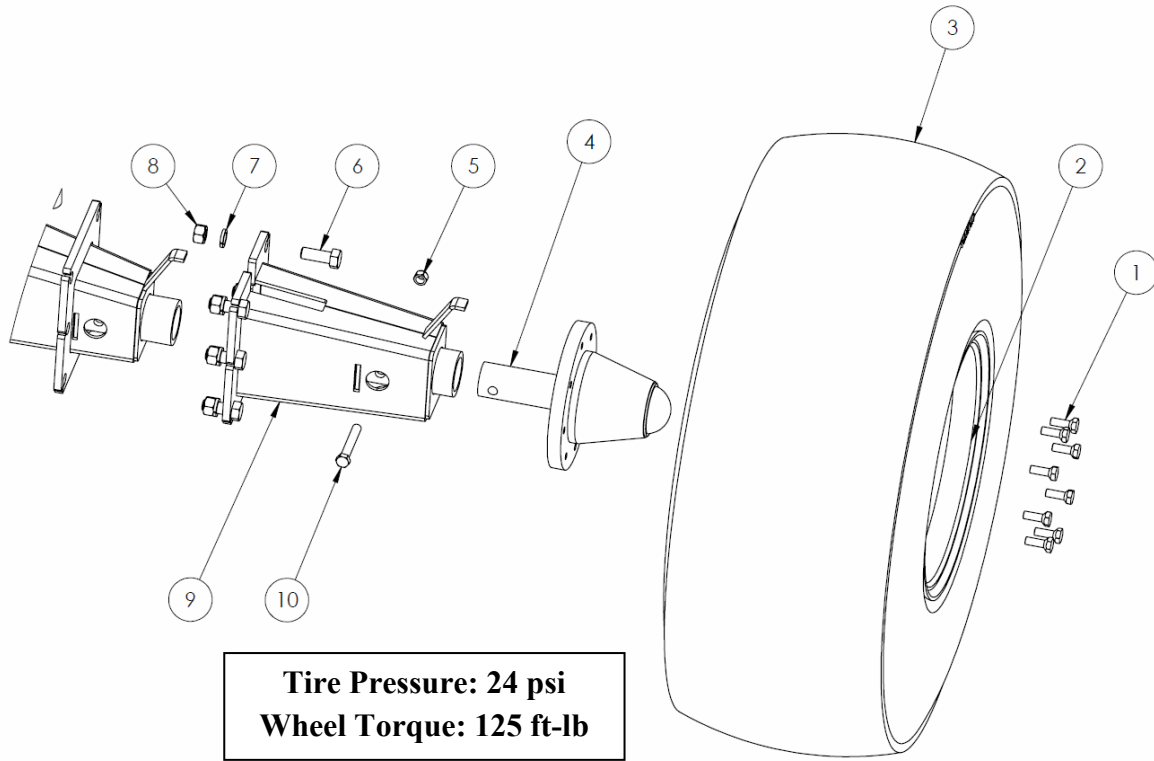

#	DESCRIPTION	PART #	QTY
1	Wheel Stud, 9/16 x 1-3/4" NF	10347	16
2	Rim, 16.1x14, 8 on 8"	10354	2
3	Tire, 16L-16.1 12 ply	See your local tire dealer	NSS
4	Hub & Spindle Assembly	See breakdown	29679
5	Stover Lock Nut, 9/16"	21165	2
6	Bolt, 3/4 x 2"	*TR ONLY*	13800
7	Flat Washer, 3/4"	*TR ONLY*	13717
8	Nut, 3/4" Stover Lock	*TR ONLY*	11823
9	Axle Extension	*TR ONLY*	30259
10	Bolt, 9/16 x 4"	33912	2

Hub & Spindle

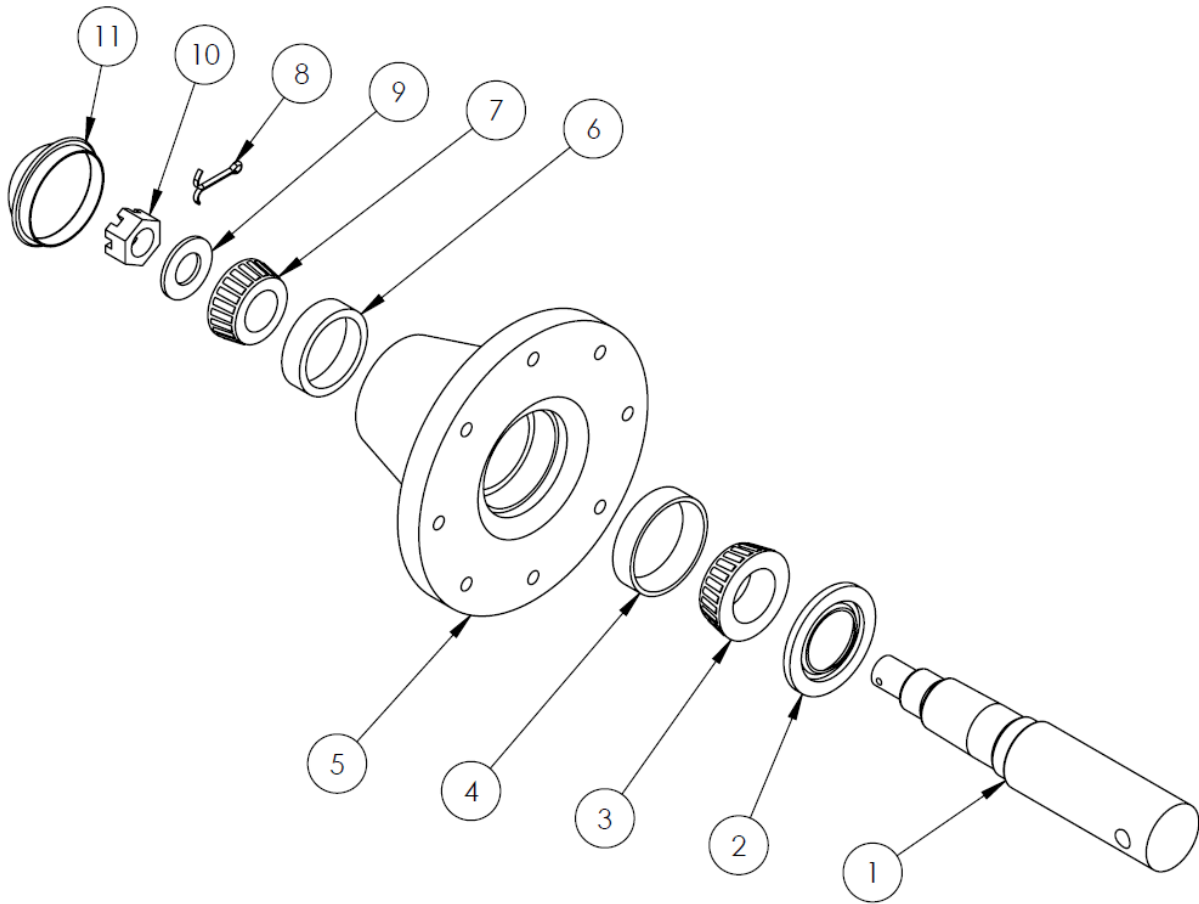

#	DESCRIPTION	PART #	QTY
	Complete Assembly	29679	1
1	6500lb Spindle	29730	2
2	Seal, 2" ID	10344	2
3	Inner Bearing Cone, 1.796" ID	LM25590	2
4	Inner Bearing Race	25520	10349
5	Hub Housing	Includes #4 & #6	10343
6	Outer Bearing Race	25821	10346
7	Outer Bearing Cone, 1-3/8" ID	LM25877	10348
8	Cotter Pin, 3/16" x 1-1/2"	10072	2
9	Flat Washer, 1-1/6" ID x 2" OD	10071	2
10	Castle Nut, 1" NF	10153	2
11	Dust Cap	10350	2

Rotor & Drive Components

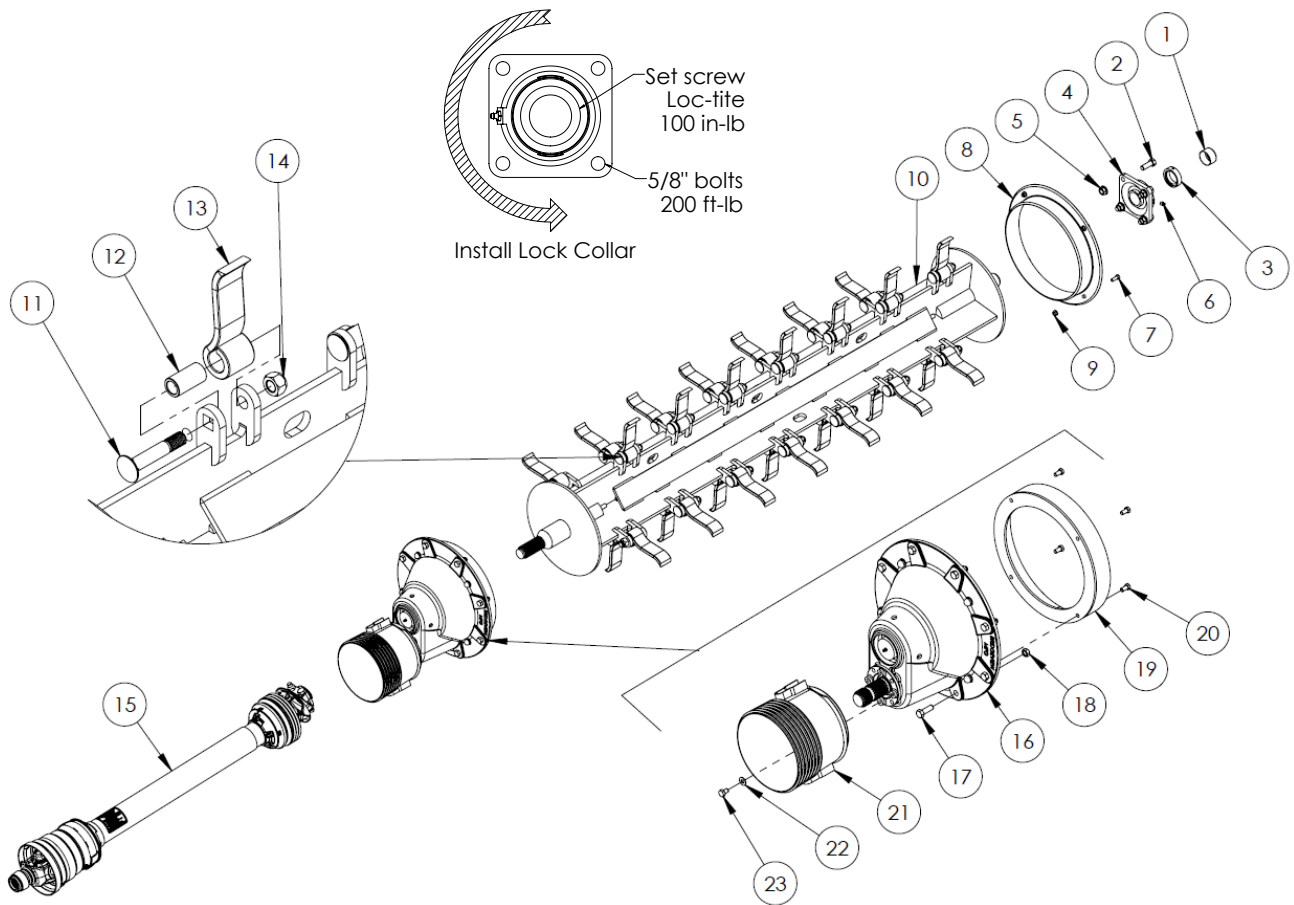

#	DESCRIPTION	PART #	QTY
1	Rotor Shaft Cap	17380	1
2	Bolt, 5/8" x 1-3/4" NF Gr. 8	10274	4
3	Lock Collar	10268	1
4	Rotor Bearing	10221	1
5	Nut, 5/8" NF Serrated Flange Gr. 8	15398	4
6	Grease Zerk, 1/8" NPT Straight	10270	1
7	Bolt, 3/8 x 1"	13806	4
8	Rotor Twine Guard, Rear	22413	1
9	Nut, 3/8" Serrated Flange	10271	4
10	X-Rotor Weldment	34982	1
11	Bolt, 3/4" x 4-1/8" Carriage	36154	28
12	Flail Bushing	35730	28
13	Rotor Flail, 2 x 6-1/4" Spring	35732	28
14	Nut, 3/4" Stover Lock	11823	28
15	PTO Shaft	20546	1
16	Gearbox	22158	1
17	Bolt, 1/2" x 1-1/2"	10174	8
18	Nut, 1/2" Stover Lock	20154	8
19	Gearbox Twine Guard	23002	1
20	Bolt, 3/8" x 3/4"	11816	4
21	PTO Safety Shield	34899	1
22	Flat Washer, 3/8"	11667	4
23	Bolt, M10 x 16	25154	4

Gearbox

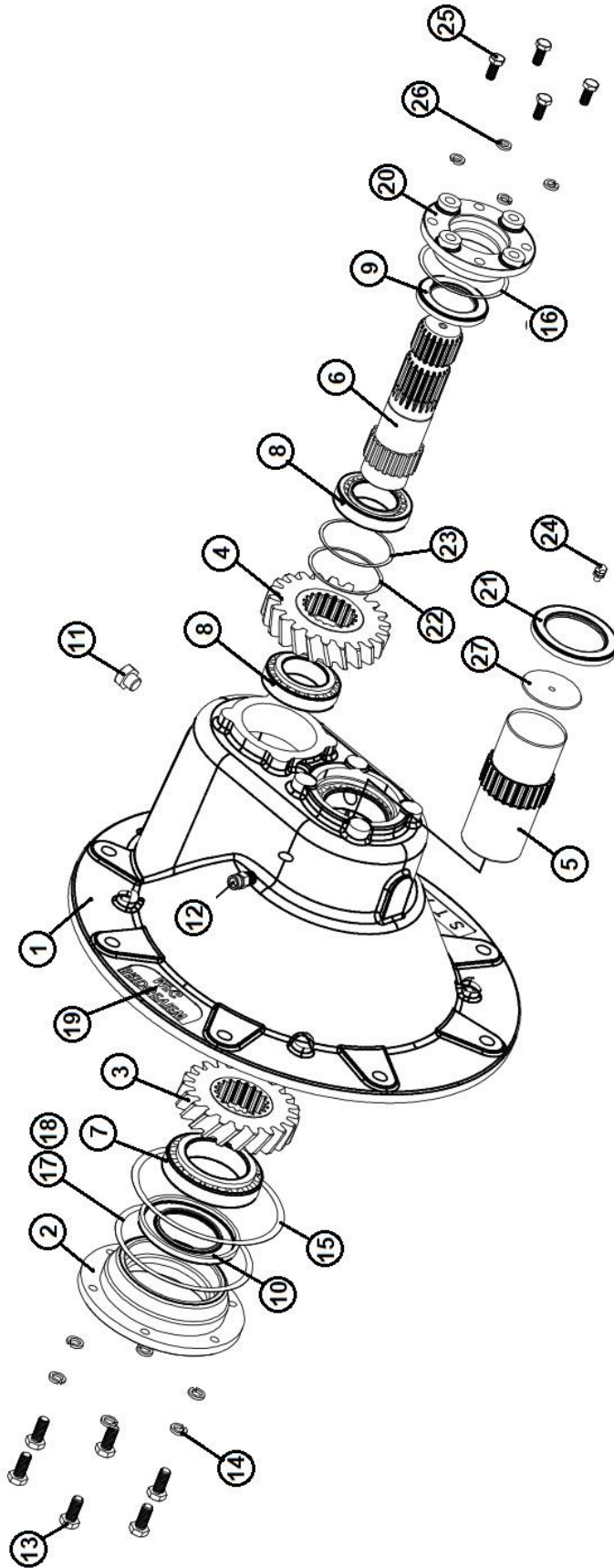

Gearbox

#	DESCRIPTION	PART #	QTY
	Complete Gearbox Assembly	22158	1
1	Housing	NSS	1
2	End Cap	NSS	1
3	Output Gear	NSS	1
4	Input Gear	NSS	1
5	Output Shaft	NSS	1
6	Input Shaft	NSS	1
7	Bearing (32012) 60mm	10496	2
8	Bearing (32009) 45mm	10497	2
9	Seal, 45 x 60 x 8	24013	1
10	Seal, 60 x 100 x 10	10498	1
11	Pipe Plug, 3/8" NPT	24014	2
12	Relief Plug, 3/8" NPT	24015	1
13	Bolt, M8 x 25 Gr. 8.8	24026	6
14	Lock Washer, M8	24016	6
15	O-Ring	24017	1
16	O-Ring	24018	1
17	Shim, 125 x 164 x 0.1	24022	2
18	Shim, 125 x 164 x 0.3	24023	2
19	Name Plate (Bridgeview)	NSS	1
20	End Cap	NSS	1
21	Seal, 60 x 85 x 10	10500	1
22	Shim, 68 x 74.5 x 0.1	24024	2
23	Shim, 68 x 74.5 x 0.3	24025	2
24	Grease Zerk, 1/4"-28 Straight	26219	1
25	Bolt, M10 x 25	15087	4
26	Lock Washer, M10	24021	4
27	Press Cup	24446	1

PTO Shaft

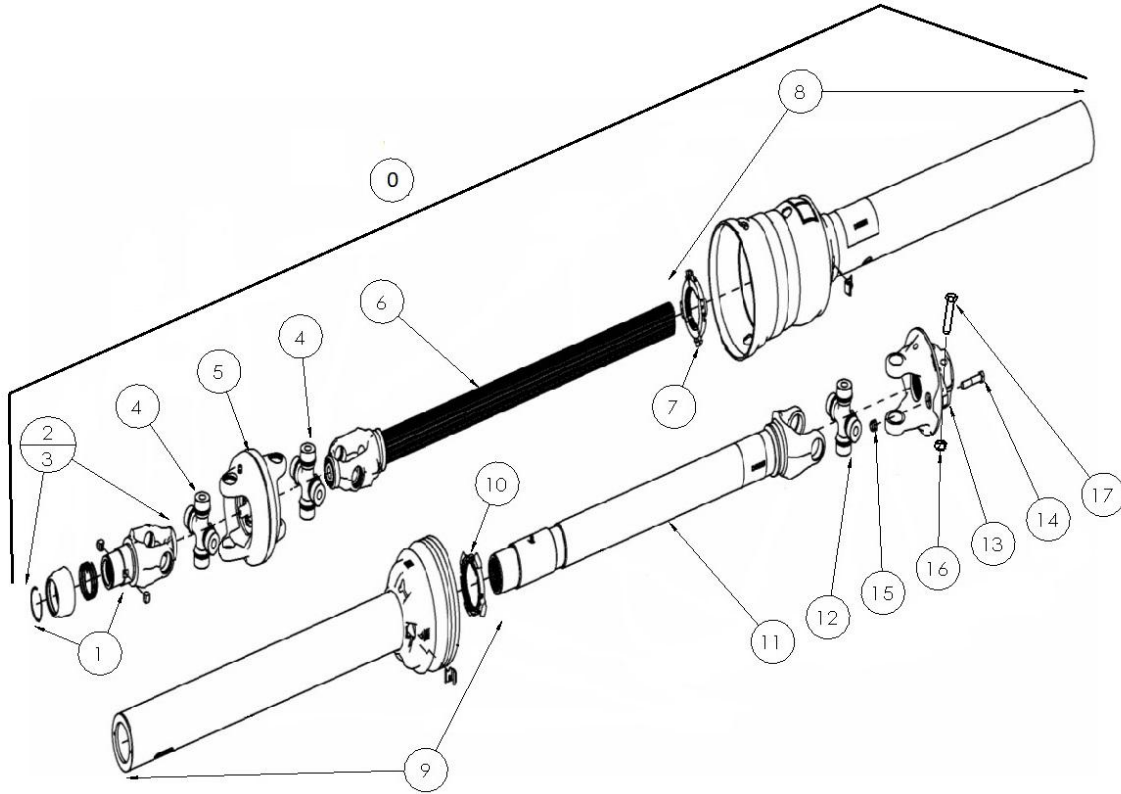

#	DESCRIPTION	PART #	QTY
	Complete PTO Shaft Assembly (1-3/8")	20546	1
0a	Tractor Half PTO Assembly (1-3/8"-21 Spline)	32505	1
0b	Tractor Half PTO Assembly (1-3/4"-20 Spline)	32506	
1a	Safety Slide Lock Repair Kit (1-3/8"-21 Spline)	17567	1
1b	Safety Slide Lock Repair Kit (1-3/4"-20 Spline)	24981	
2	WWCV Auto-Lok Yoke Assembly (1-3/8"-21 Spline)	20549	1
3	WWCV Auto-Lok Yoke Assembly (1-3/4"-20 Spline)	20556	
4	CV Cross and Bearing Kit (Equal Length)	20550	2
5	CV Center Housing	20551	1
6	Yoke & Shaft Assembly Tractor Side	20552	1
7	Guard Repair Kit Tractor Side	20553	1
8	Guard Assembly Tractor Side	17583	1
9	Guard Assembly Implement Side	17585	1
10	Guard Repair Kit Implement Side	17572	1
11	Yoke & Tube Assembly Implement Side	17584	1
12	U-joint Cross & Bearing Kit	17573	1
13	Shear Assembly * Does not come with bolts 14 or 17 *	29963	1
14	Shear Bolt, 3/8" x 2" Fine Thread	33285	1
15	Nut, 3/8" Fine Thread Stover Lock	33286	1
16	Nut, 5/8" Stover Lock	24982	2
17	Bolt, 5/8" x 3-1/2"	24983	2

NOTE: Ensure that the PTO shaft on the machine is correct to the drawings below. Equal length CV cross (4.19") with bearing cup diameter 1.38". If the damaged PTO has different dimensions, consult the Bridgeview Manufacturing website.

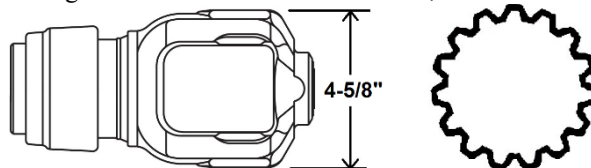

Grates

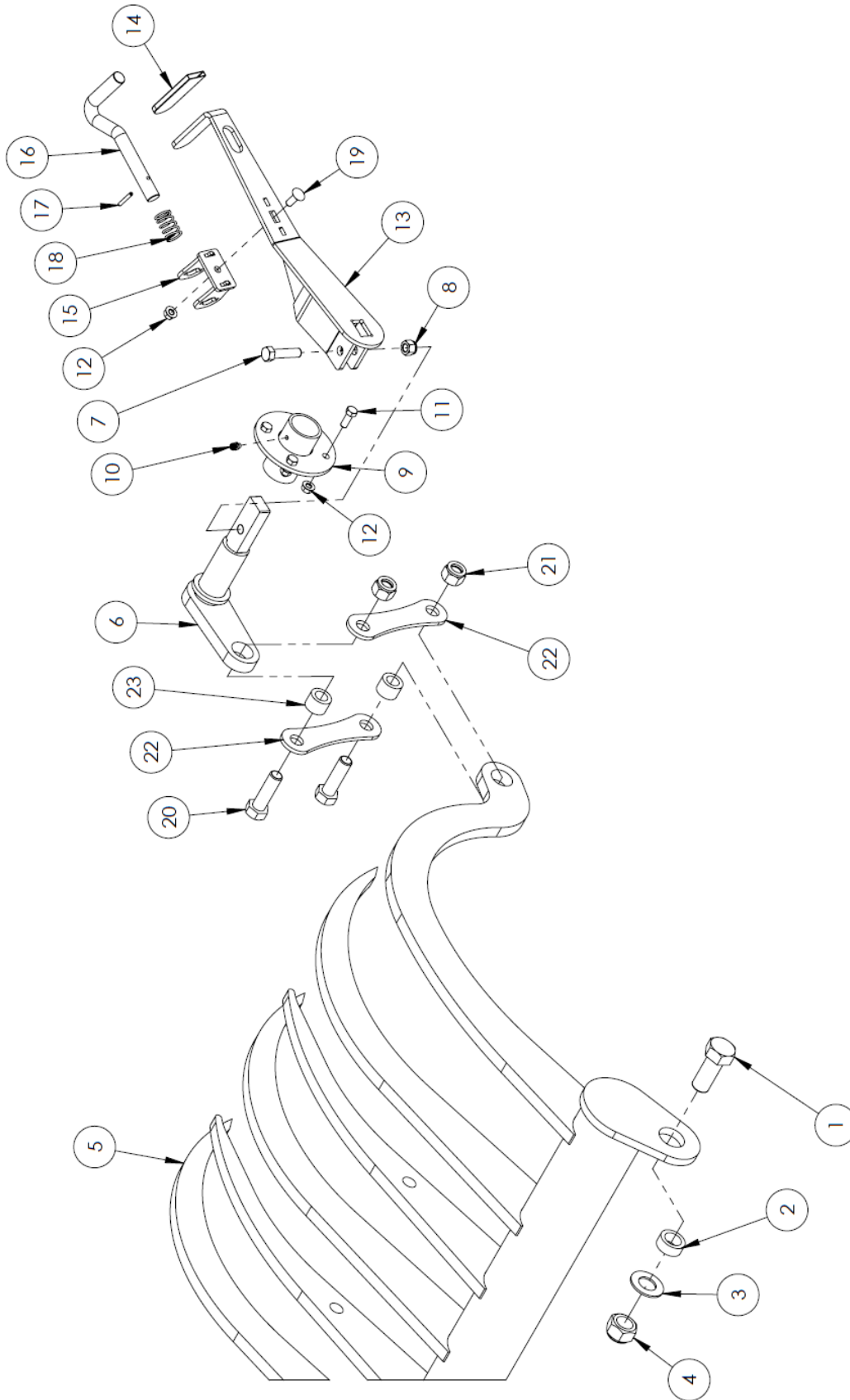

Grates

#	DESCRIPTION	PART #	QTY	
1	Bolt, 1" x 2-1/2"	21820	2	
2	Grate Pivot Bushing	22417	2	
3	Flat Washer, 1"	14472	2	
4	Nut, 1" Stover Lock	21746	2	
5	Grate Assembly	36049	1	
6	Grate Adjustment Cam	36026	1	
7	Bolt, 1/2" x 2"	10322	1	
8	Nut, 1/2" Nylon Lock	10241	1	
9	Grate Handle Pivot	31715	1	
10	Grease Zerk, 1/4"-28 x 45°	20888	1	
11	Bolt, 3/8" x 1"	13806	4	
12	Nut, 3/8" Serrated Flange	10271	5	
13	Grate Handle	Comes with #12,15,19	31725	1
14	Rubber Cover	10297	1	
15	Handle Spring Guide	33693	1	
16	S-Handle	22187	1	
17	Roll Pin, 3/16" x 1-1/4"	10302	1	
18	Grate Handle Spring	34465	1	
19	Bolt, 3/8 x 1" Carriage	15718	1	
20	Bolt, 3/4" x 2-1/4"	29824	2	
21	Nut, 3/4" Stover Lock	11823	2	
22	Grate Shackle	31709	2	
23	Grate Shackle Bushing	22415	2	

Rollers

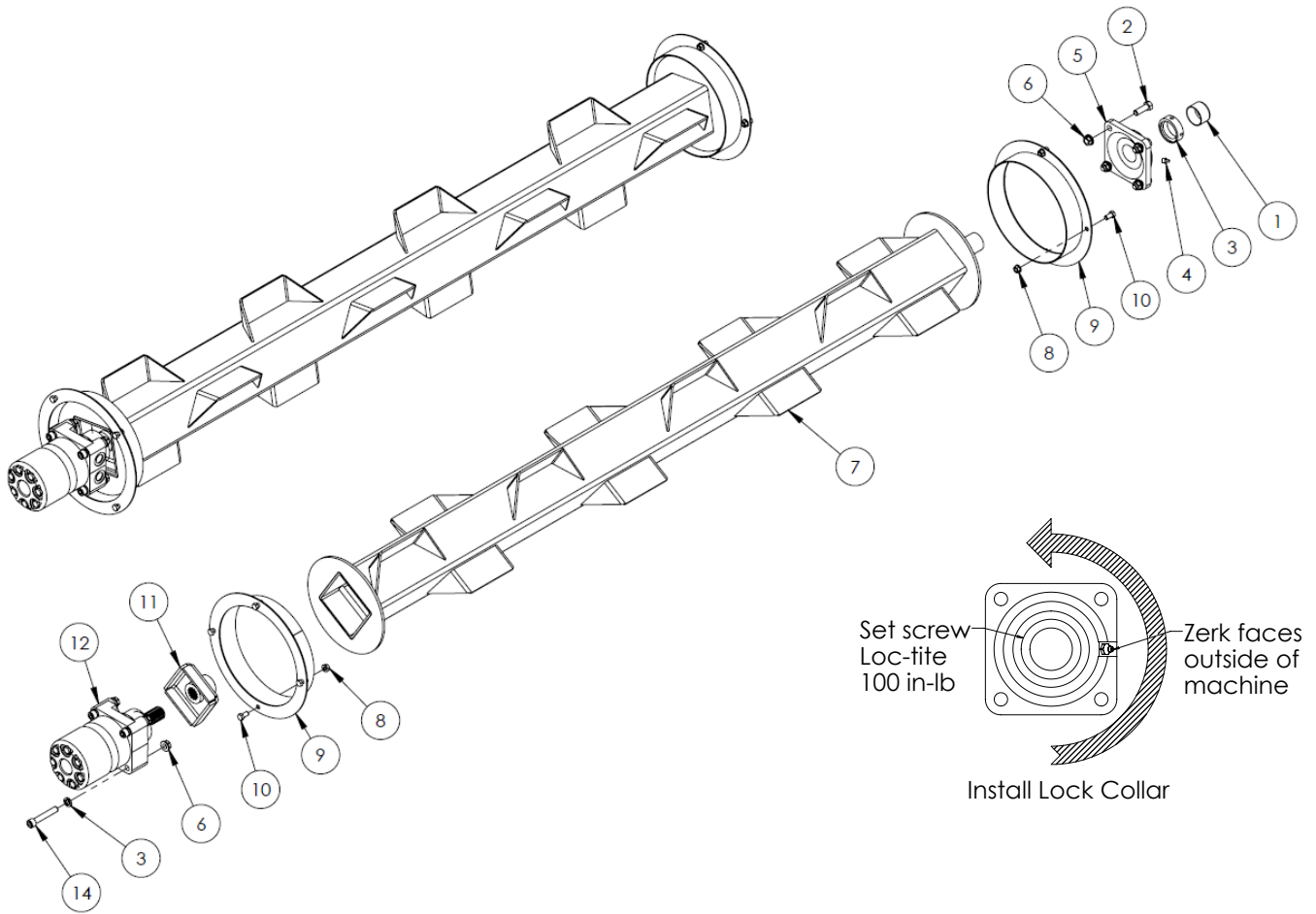

#	DESCRIPTION	PART #	QTY
1	Roller Shaft Cap	17381	2
2	Bolt, 1/2" x 1-1/2"	10174	8
3	Lock Collar	10040	2
4	Grease Zerk, 1/8" NPT Straight	10270	2
5	Roller Bearing	Includes # 3 & 4 10038	2
6	Nut, 1/2" Serrated Flange	10273	16
7	Roller	36051	2
8	Nut, 3/8" Serrated Flange	10271	16
9	Roller Twine Guard	22419	4
10	Bolt, 3/8" x 3/4"	11816	16
11	Roller Insert	22084	2
12	Roller Motor, 8" Long * Seal Kit	25872 25891	2
13	Lock Washer, 1/2"	14447	8
14	Socket Head Bolt, 1/2" x 3"	25952	8

Wings & Front Rack

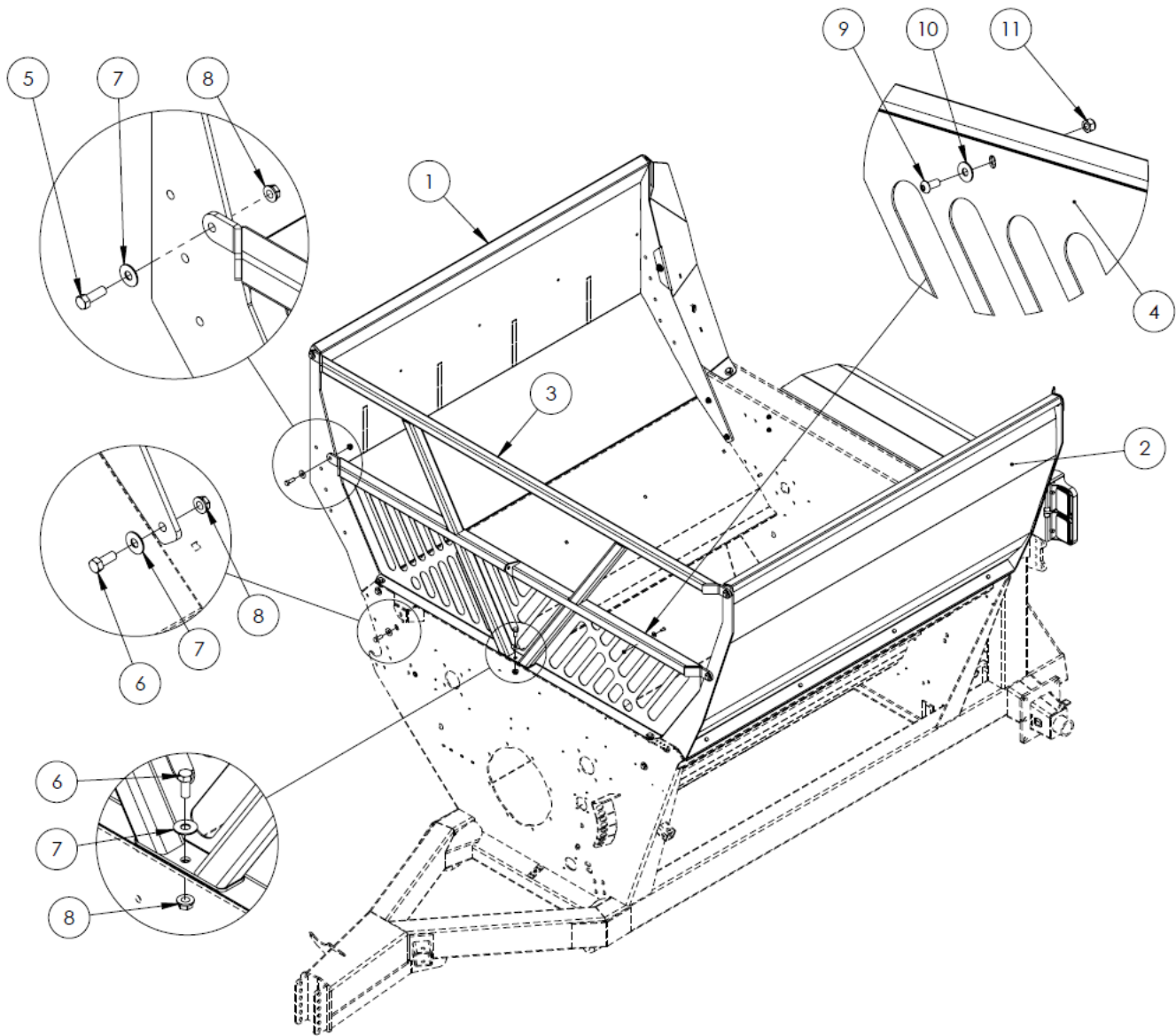

#	DESCRIPTION	PART #	QTY
1	Discharge Side Wing	36057	1
2	Non-Discharge Side Wing	36055	1
3	Front Rack	36053	1
4	Front Rack Grating	36042	1
5	Bolt, 1/2" x 1 1/2"	10174	4
6	Bolt, 1/2" x 1 1/4"	10240	7
7	Flat Washer, 1/2"	11668	1
8	Nut, 1/2" Serrated Flange	10273	7
9	Bolt, 5/16" x 3/4" Button Head	32513	8
10	Washer, 5/16" Flat	12496	8
11	Nut, 5/16" Nylon Lock	11815	8

Rear Wings & Lights

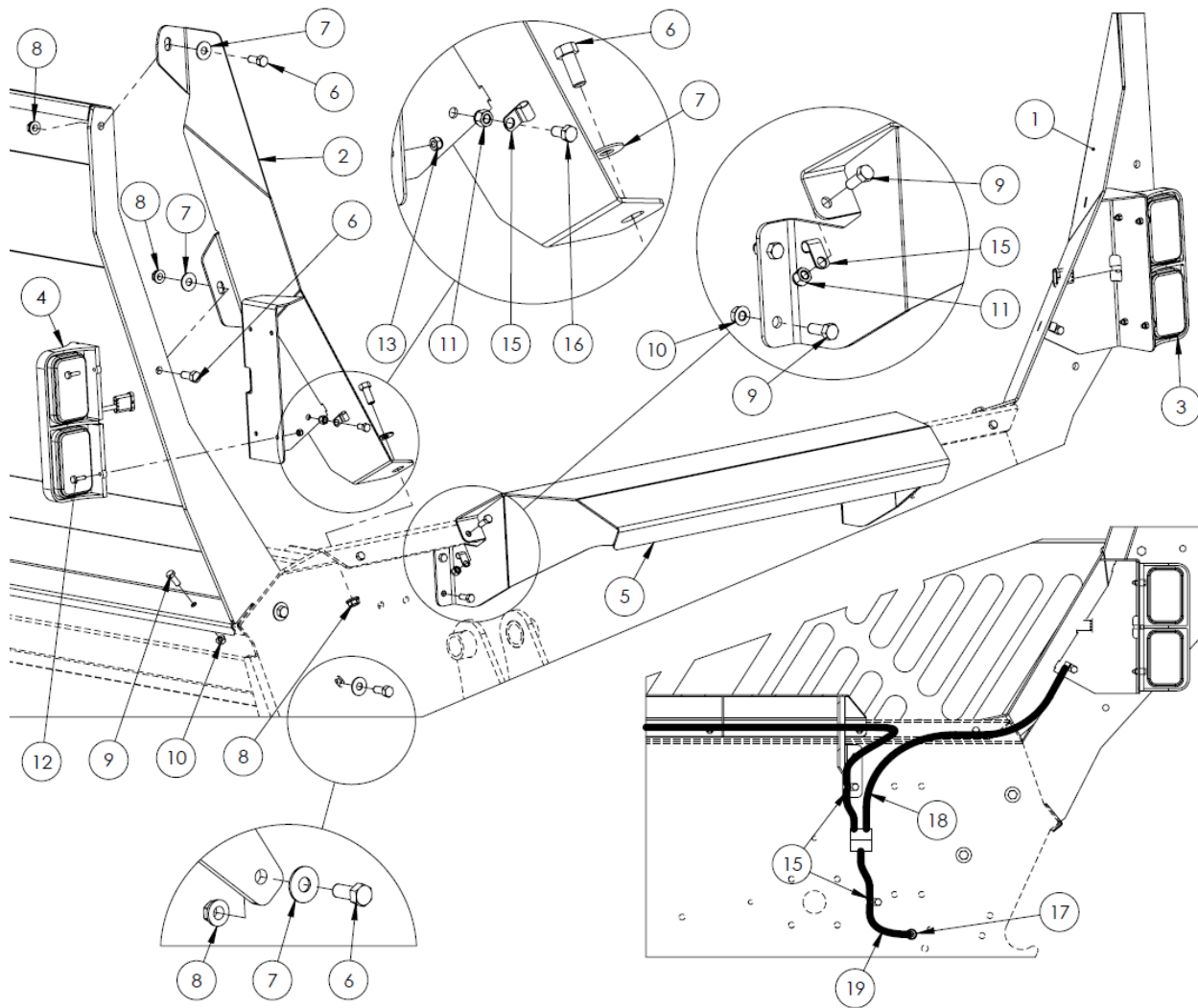

#	DESCRIPTION	PART #	QTY
1	Rear Deflector, Right Hand	36061	1
2	Rear Deflector, Left Hand	36059	1
3	Light Assembly, Right Hand	31088	1
4	Light Assembly, Left Hand	31087	1
5	Rear Deflector, Center	33713	1
6	Bolt, 1/2 x 1-1/4"	10240	10
7	Flat Washer, 1/2"	11668	10
8	Nut, 1/2" Serrated Flange	10273	10
9	Bolt, 3/8" x 1"	13806	20
10	Nut, 3/8" Serrated Flange	10271	12
11	Nut, 3/8" Nylon Lock	10806	8
12	Bolt, 1/4 x 1"	11810	8
13	Nut, 1/4" Nylon Lock	11664	8
14	Wing	-	1
15	Wiring Clamp	13629	10
16	Bolt. 3/8 x 3/4"	11816	2
17	Grommet	21428	1
18	Wishbone Harness	33026	1
19	Main Harness	31646	1

Lights & Harness

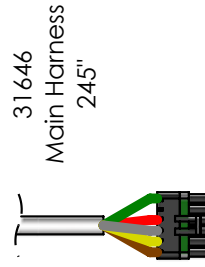
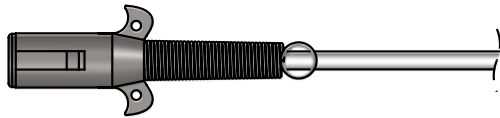
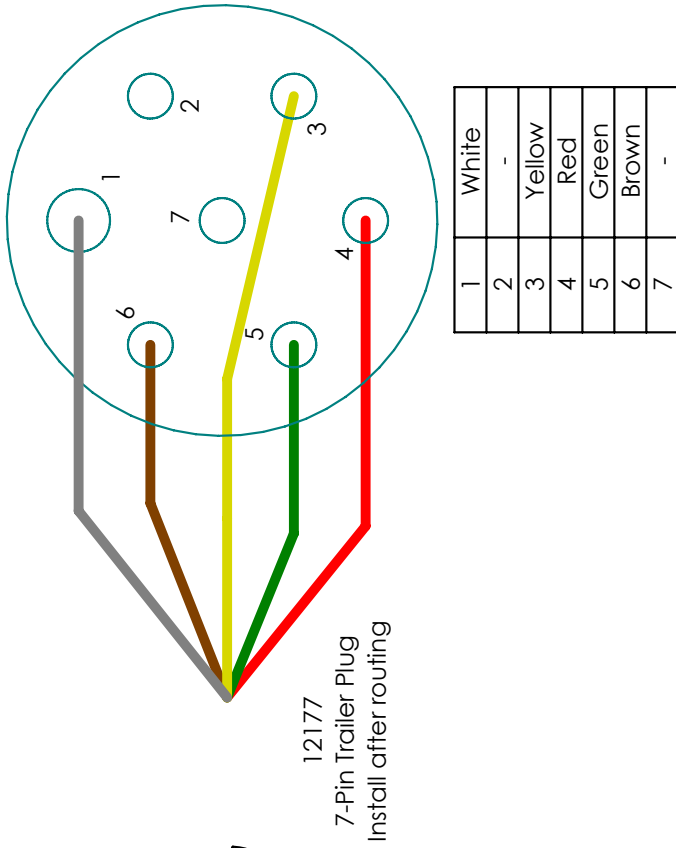

	Left	Right
A	Brown	Brown
B	Yellow	-
C	White	White
D	Red	Red
E	-	-
F	-	Green

A	Brown
B	Yellow
C	White
D	Red

33026
Wishbone Harness
65" Left / 18" Right

A	Brown
B	Green
C	White
D	Red

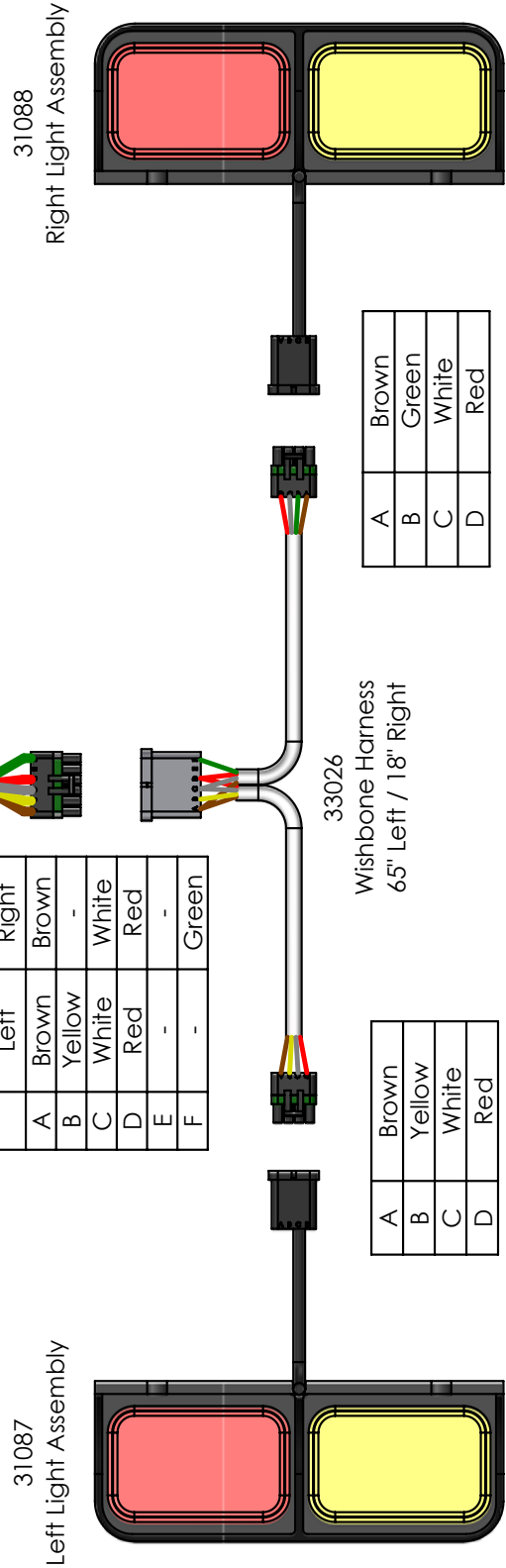

Rear Forks

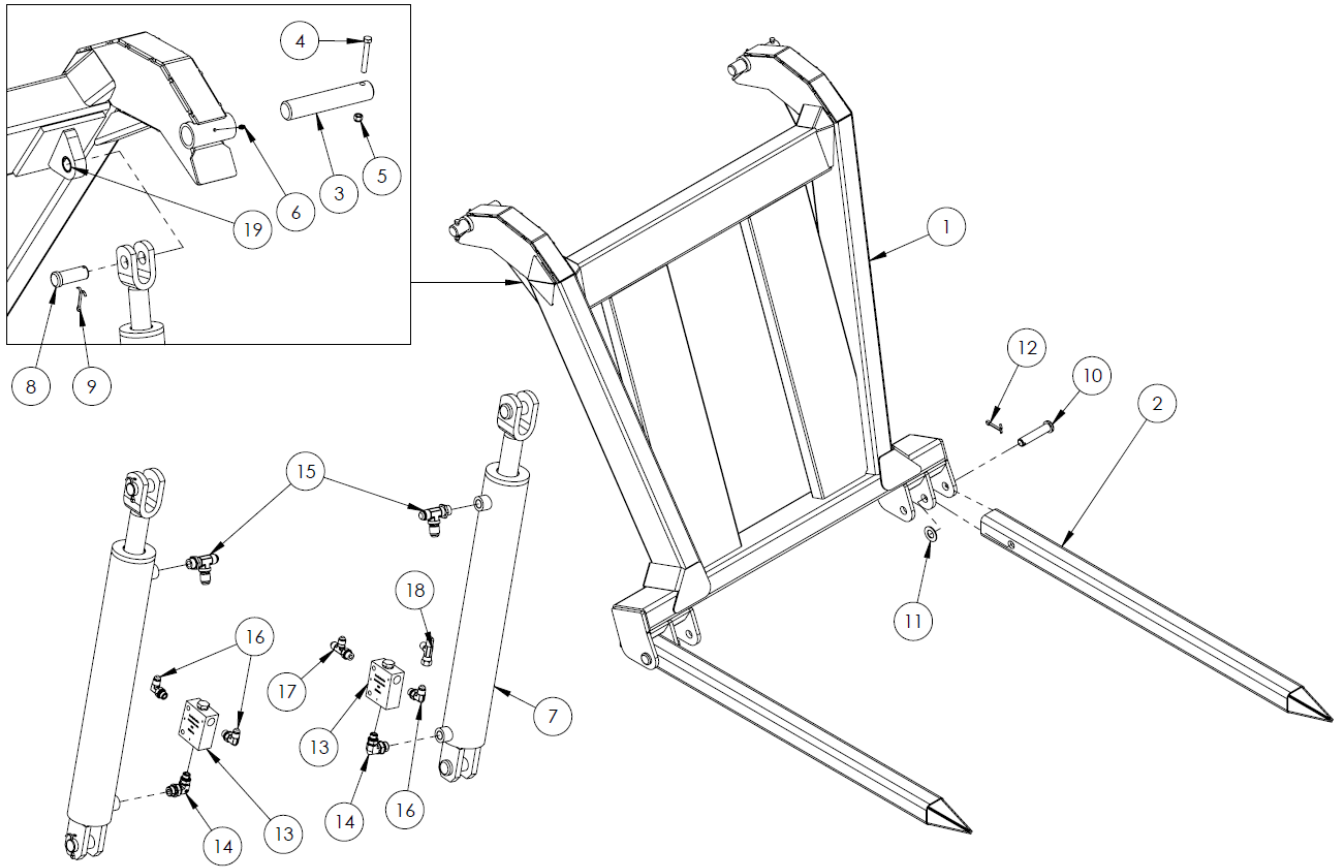

#	DESCRIPTION	PART #	QTY
1	Tapered Rear Fork Frame	33759	1
2	Fork Tine	36150	2
3	Rear Fork Pivot Pin	22006	2
4	Bolt, 3/8" x 2-3/4"	20908	2
5	Nut, 3/8" Nylon Lock	10806	2
6	Grease Zerk, 1/4"	16364	2
7	Hydraulic Cylinder, 3" x 18" x 1-1/2" * Replacement Shaft * Seal Kit	21717 31034 20807	2
8	Cylinder Pin, 1 x 2-1/4" Usable	36027	4
9	Cotter Pin, 3/16" x 1-1/2"	10072	4
10	Fork Tine Pin	10031	2
11	Flat Washer, 1"	14472	2
12	Cotter Pin, 1/4" x 2"	10580	2
13	Hydraulic Check Valve	19114	2
14	Hyd. Fitting, 8MB - 6MB90	33739	2
15	Hyd. Fitting, 8MBR - 8MJT	22159	2
16	Hyd. Fitting, 6MB - 6MJ90	10201	3
17	Hyd. Fitting, 6MBR - 6MJT	23726	1
18	Hyd. Fitting, 6FJXR - 6MJT	15760	1
19	Bushing Insert, 1"	23708	4

Deflector & Hose Cover

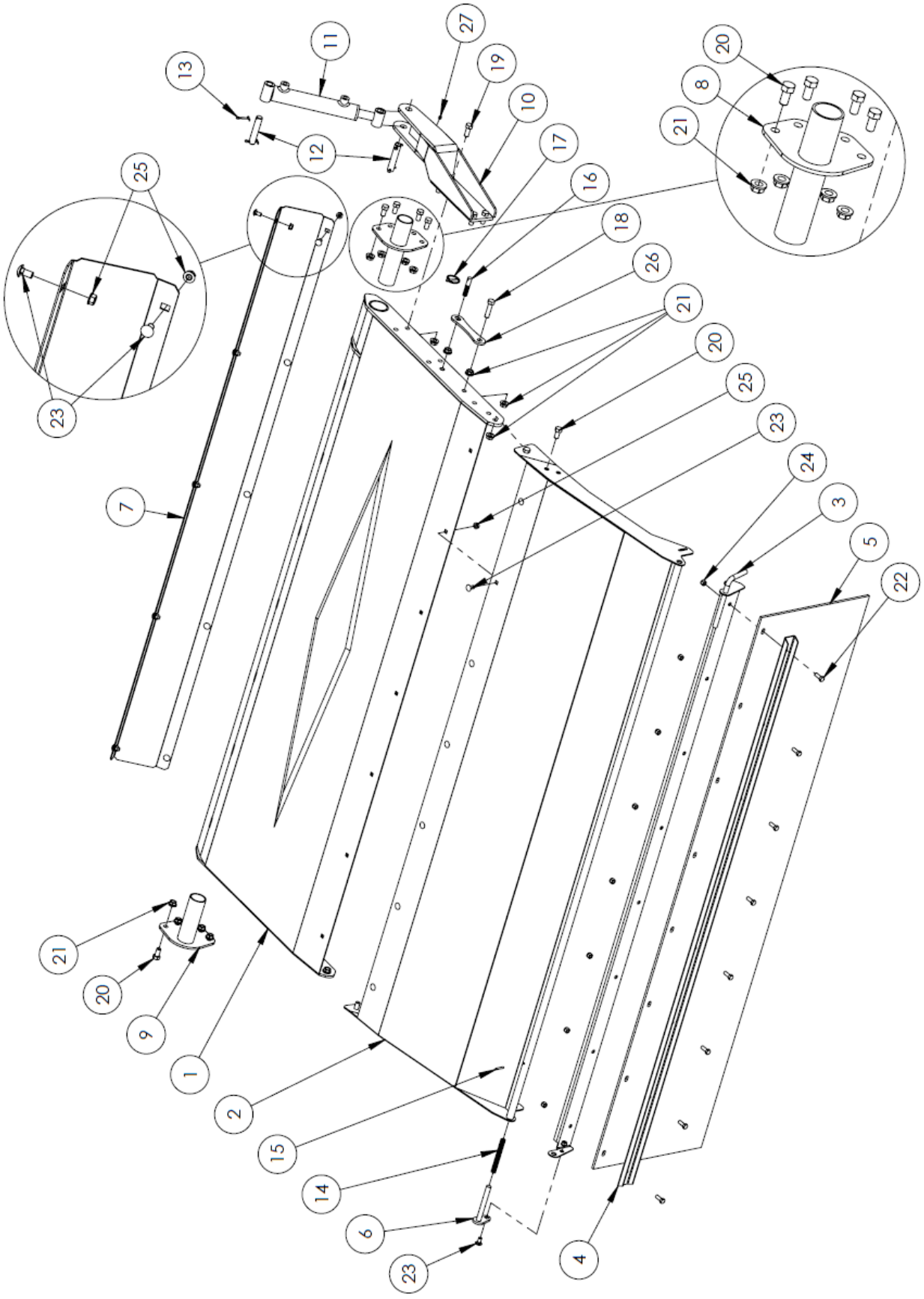

Deflector & Hose Cover

#	DESCRIPTION	PART #	QTY
1	Inner Deflector	36055	1
2	Outer Deflector	31754	1
3	Deflector Rubber Flipper	24463	1
4	Deflector Rubber Channel	22423	1
5	Deflector Rubber	10477	1
6	Deflector Flipper Pin	24464	1
7	Hose Cover	36041	1
8	Deflector Pivot Front	36063	1
9	Deflector Pivot Rear	33715	1
10	Deflector Cylinder Mount	36067	1
11	Hydraulic Cylinder, 1-1/2" x 6" x 1" * Seal Kit	21711 23738	1
12	Cylinder Pin, 3/4" x 3" Usable	22007	2
13	Cotter Pin, 3/16" x 1-1/4"	11669	4
14	Compression Spring	24461	1
15	Roll Pin, 3/16" x 1-1/4"	10302	1
16	Stud Pin	13231	1
17	Lynch Pin	13233	1
18	Bolt, 1/2" x 2"	10322	1
19	Bolt, 1/2 x 1-1/4"	10240	4
20	Bolt, 1/2" x 1"	10824	12
21	Nut, 1/2" Serrated Flange	10273	20
22	Bolt, 3/8" x 1"	13806	8
23	Carriage Bolt, 3/8" x 3/4"	14072	18
24	Nut, 3/8" Nylon Lock	10806	8
25	Nut, 3/8" Serrated Flange	10271	18
26	Deflector Lock	22422	1
27	Grease Zerk, 1/4"	16364	1

Front Tub Components

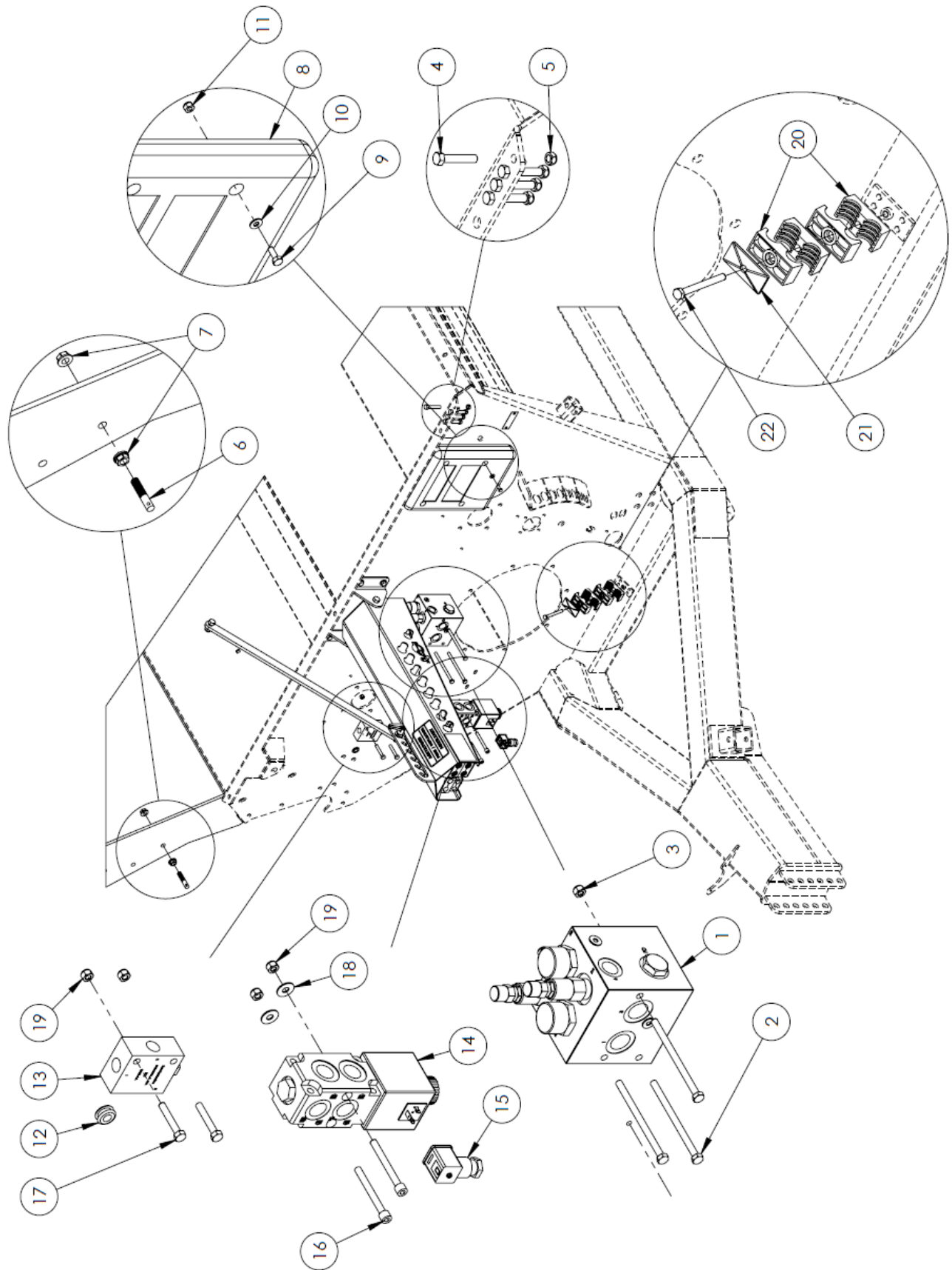

Front Tub Components

#	DESCRIPTION	PART #	QTY
1	Flow Divider Valve	25778	1
2	Bolt, 5/16 x 5"	36321	3
3	Nut, 5/16" Nylon Lock	11815	3
4	Shear Bolt, 3/8" x 2" Fine Thread Gr. 5	33285	4
5	Nut, 3/8" Fine Thread Stover Lock	33286	4
6	Stud Pin	13231	1
7	Nut, 1/2" Serrated Flange	10273	2
8	Operator Manual Holder	22409	1
9	Flat Washer, 1/4"	11666	4
10	Bolt, 1/4" x 3/4"	11809	4
11	Nut, 1/4" Nylon Lock	11664	4
12	Grommet	21428	1
13	Pilot Check Valve	19114	A/R
14	Diverter Valve # * Double Stack Kit * Triple Stack Kit * Nut & O-Ring Kit * Magnet Kit	For joining 2 valves For joining 3 valves 11743 12895 12897 17977 11798	A/R
15	Valve Plug	One per valve. Harness sold separately.	A/R
16	Bolt, 5/16 x 3" Socket Head	11783	2
17	Bolt, 5/16 x 2"	15572	2
18	Washer, 5/16" Flat	12496	2
19	Nut, 5/16" Nylon Lock	11815	4
20	Hose Clamp, 1/2" Hose Clamp, 3/8"	TR Kit 3 Bale Kit 21561 22180	A/R
21	Hose Clamp Top	21725	A/R
22	Bolt, 5/16 x 3-1/4" Bolt, 5/16 x 1-3/4"	Double Stack Single Stack 34756 21726	A/R

NOTE: See page 64 for information on the control box

Hose Holder

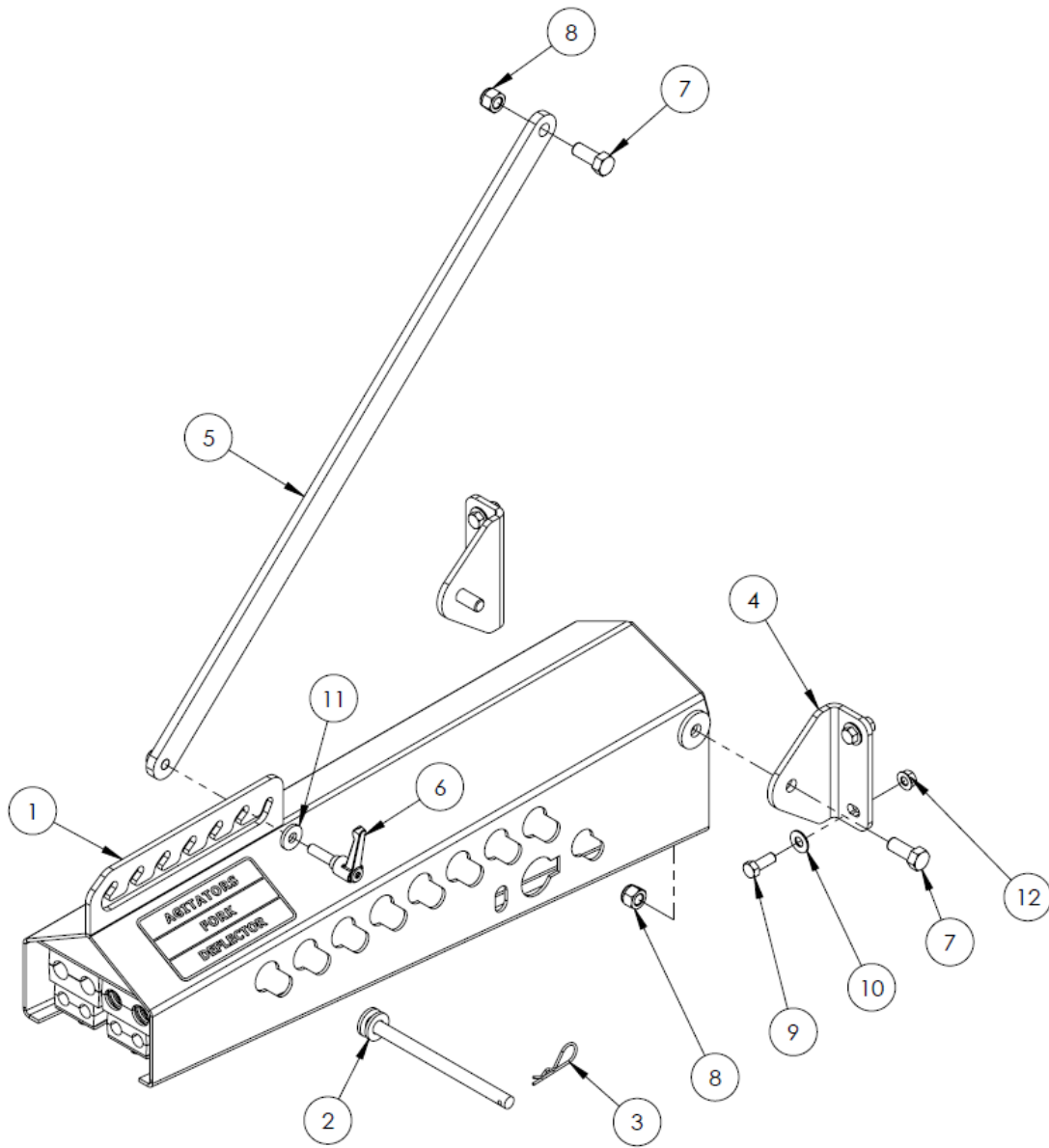

#	DESCRIPTION	PART #	QTY
1	Adjustable Hose Holder	36072	1
2	Hose Holder Pin	31745	1
3	Hairpin, 3/32 x 5/8"	11786	1
4	Hose Holder Pivot Bracket	36043	2
5	Hose Holder Linkage	35040	1
6	Threaded Adjustable Handle	34944	1
7	Bolt, 1/2 x 1-1/4"	10240	3
8	Nut, 1/2" Nylon Lock	10241	3
9	Bolt, 3/8" x 1"	13806	4
10	Flat Washer, 3/8"	11667	4
11	Flat Washer, 3/8" Heavy	33189	1
12	Nut, 3/8" Serrated Flange	10271	4

Hose Clamps

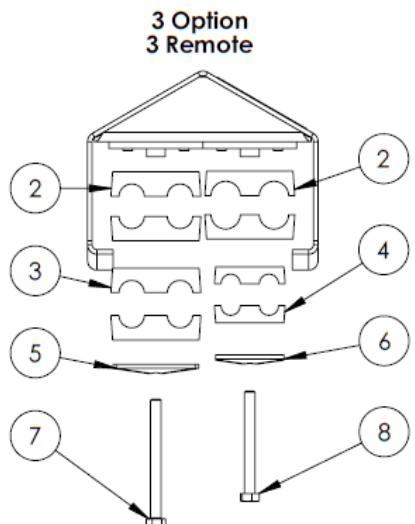
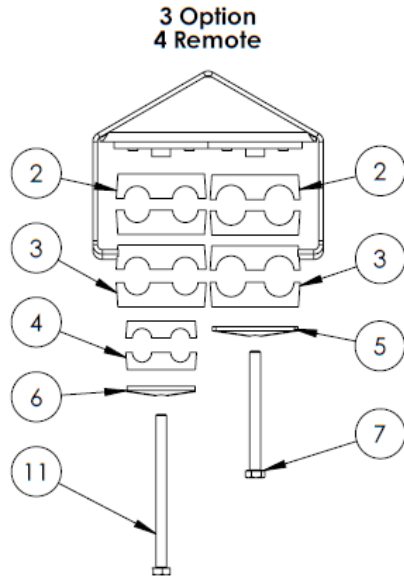
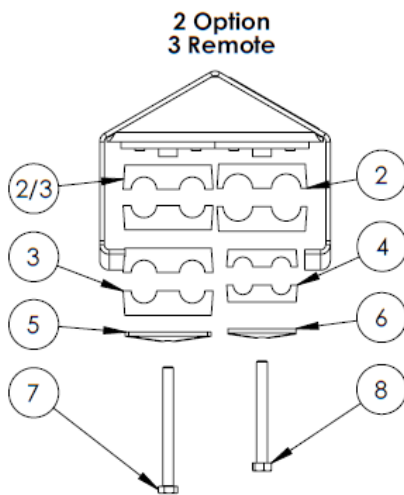
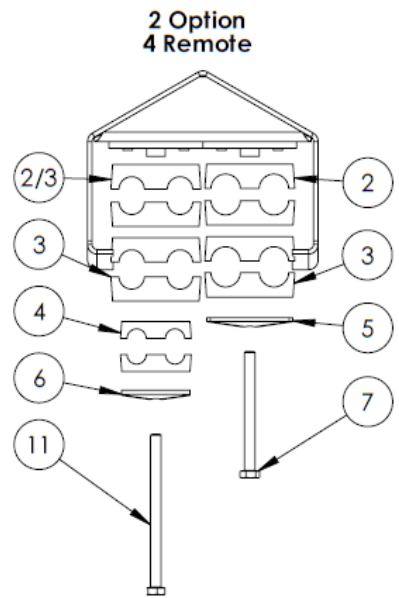
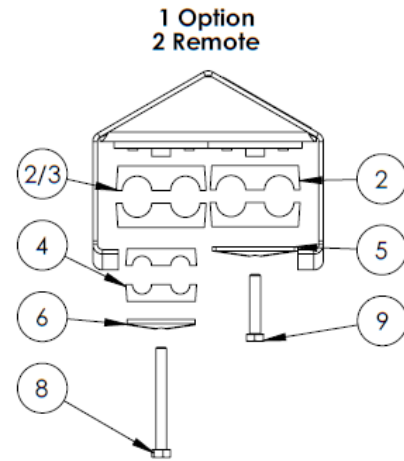
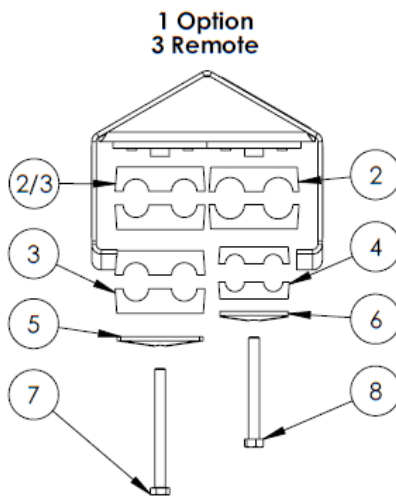
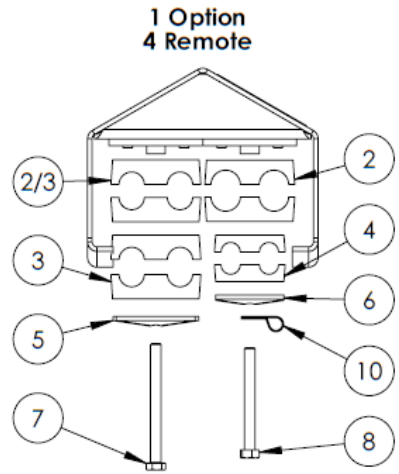
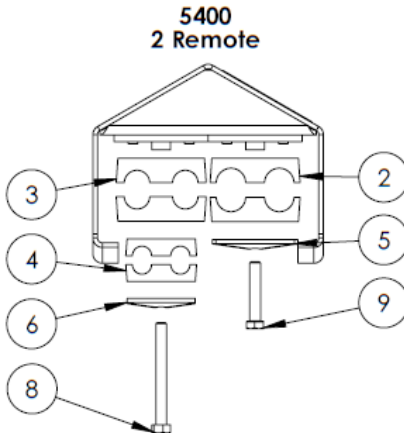
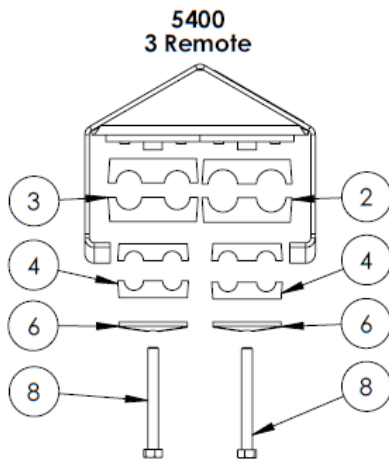

Hose Clamps...continued

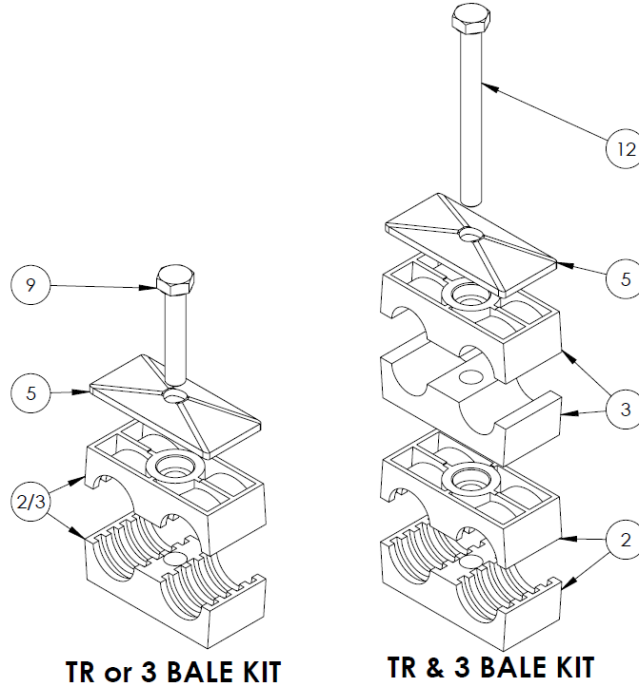

**LEFT FRAME RAIL
FRONT CROSS MEMBER**

#	DESCRIPTION	PART #
1	Hose Holder	36072
2	Hydraulic Hose Clamp, 1/2"	21561
3	Hydraulic Hose Clamp, 3/8"	22180
4	Hydraulic Hose Clamp, 1/4"	22181
5	Hydraulic Hose Clamp Cap, Large	21725
6	Hydraulic Hose Clamp Cap, Small	22182
7	Bolt, 5/16" x 3-1/2"	13765
8	Bolt, 5/16" x 3"	22844
9	Bolt, 5/16" x 1-3/4"	21726
10	Wiring Clamp	13629
11	Bolt, 5/16" x 4-1/2"	21836
12	Bolt, 5/16 x 3-1/4"	34756

NOTE: Quantities are as required

Diverter Control Box

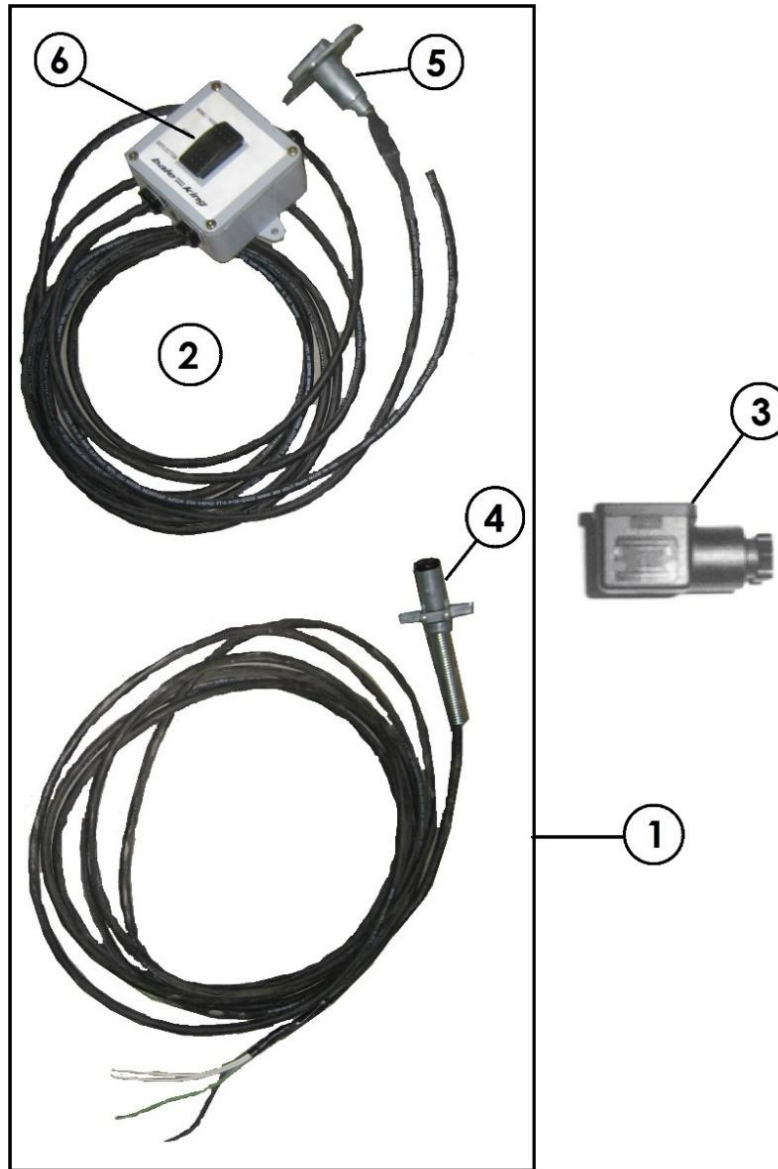

#	DESCRIPTION	PART #	QTY
1	Complete Control Box with Harness (Standard)	24466	1
	Complete Control Box with Harness (4 Function) #	33134	
	Control Box Decal (4 Function)	36147	
2	Complete Control Box with Cab to Hitch Harness (5400 Series)	NSS	1
3	Square Plug for Diverter Valve	13657	*
4	4-pin Trailer Plug	24691	1
5	4-pin Tractor Plug	24690	1
6	3-way Switch	13561	1

* NOTE: 1 plug is needed for each diverter valve.

NOTE: Only used on 5400 3 Option with 3-remote kit (3 diverter valves)

Diverter Machine Side Harness

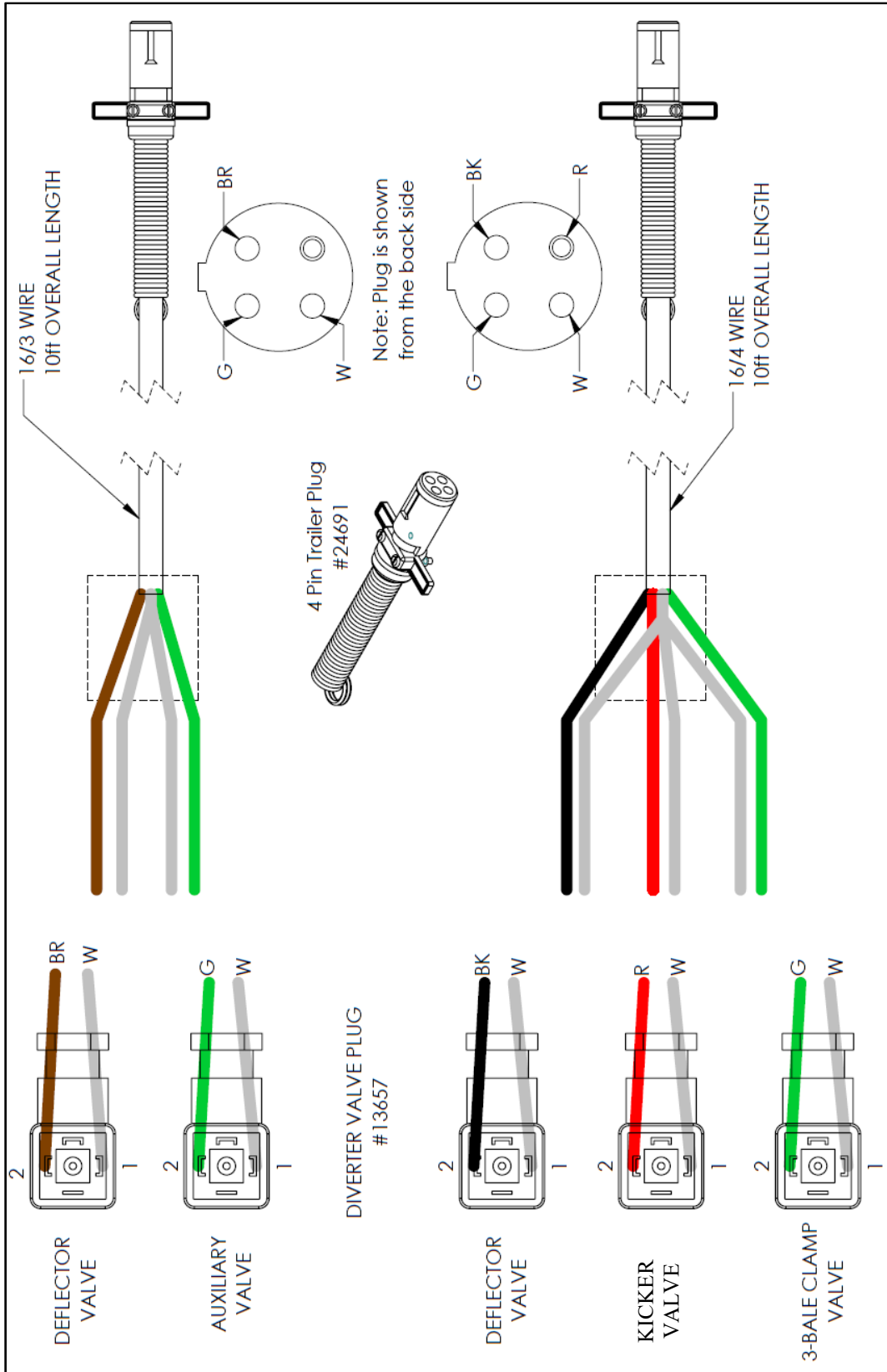

Diverter Control Box #24466

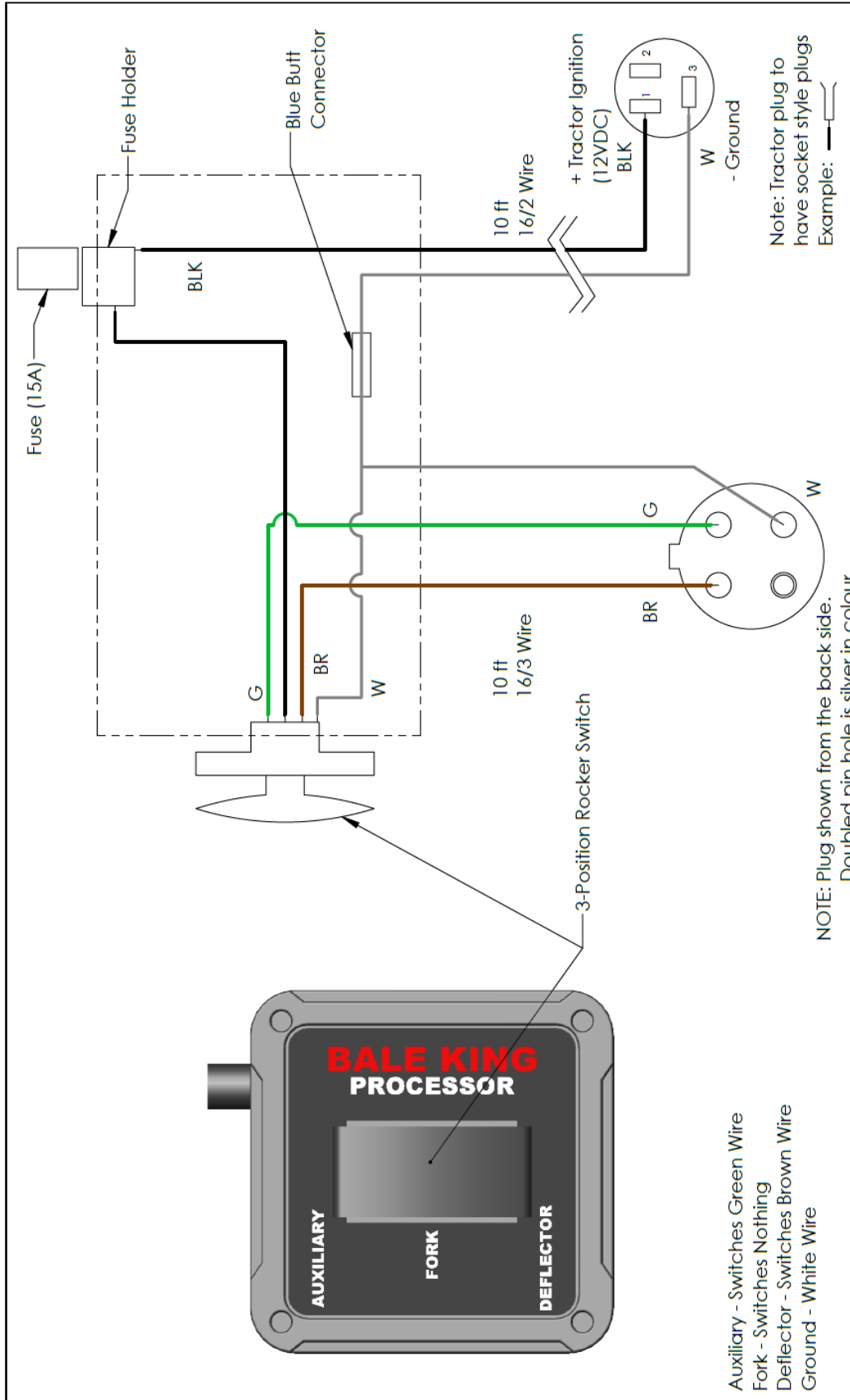

Diverter Control Box #33134
(4 Function with Additional Push Button Switch)
Requires Label Decal #36147

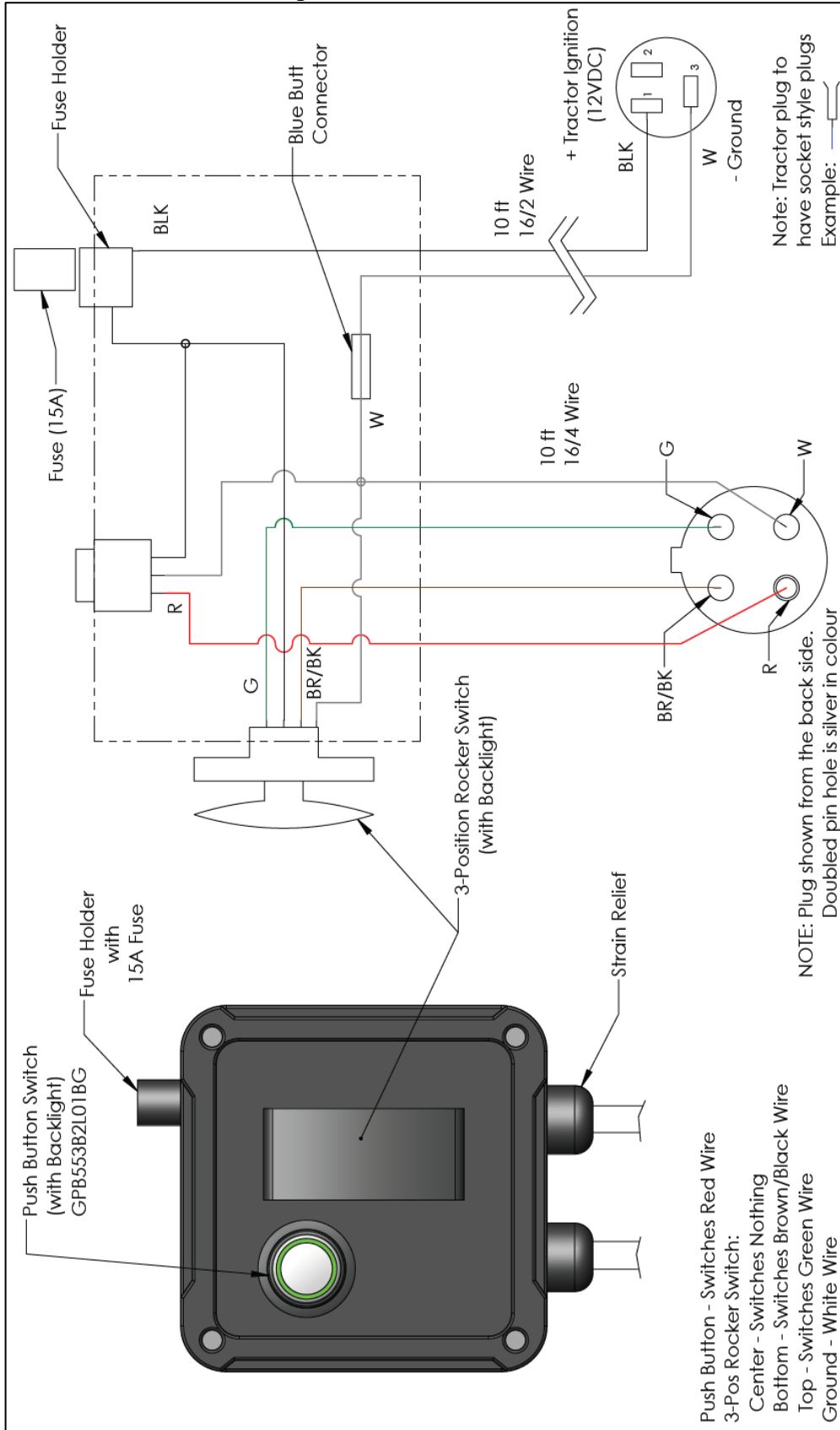

Decals



2

3

4

5

6

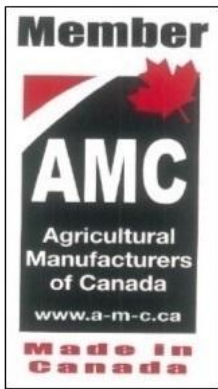

7



8



9



10

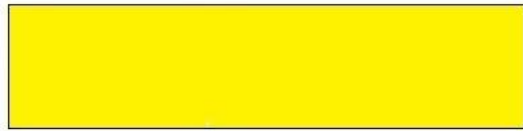

12

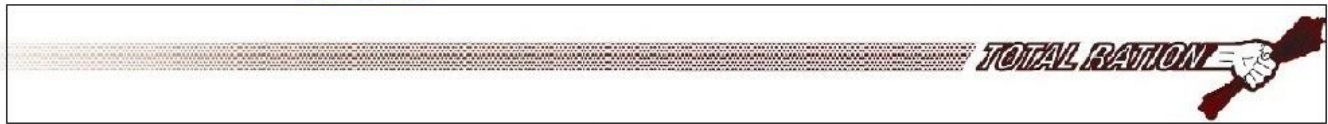

13



14



DECALS

#	DESCRIPTION	PART #	QTY
1	"BALE KING" "5400"	32804	2
		34839	2
2	"DANGER", PTO	12219	2
3	"DANGER", Discharge	12230	4
4	"DANGER", Stand Clear of Lift	12229	2
5	AMC Member	12239	1
6	FEMA Member	25347	1
7	Wheel Torque Reminder	28385	2
8	Deflector Safety Lock	22292	1
9	Red Reflector	28383	1
10	Amber Reflector	28384	4
11	Hoop Adjustment	32782	
12	Total Ration **TR Only**	24862	1
13	Speed Limit Decal	33159	
14(a)	Hyd. Decal (0 Option, 3 Remote Machine)	33137	1
14(b)	Hyd. Decal (0/1 Option, 2 Remote Machine)	33138	
14(c)	Hyd. Decal (1 Option, 4 Remote Machine)	33140	
14(d)	Hyd. Decal (1 Option, 3 Remote Machine)	33139	
14(e)	Hyd. Decal (2 Option, 4 Remote Machine)	33142	
14(f)	Hyd. Decal (XK, 4 Remote Machine)	36144	
14(g)	Hyd. Decal (2/3 Option, 3 Remote Machine)	33141	
14(h)	Hyd. Decal (XK, 3 Remote Machine)	36145	
14(i)	Hyd. Decal (3 Option, 4 Remote Machine)	36146	

***NOTE:** Options refer to either the Three Bale Kit (X), Rotary Straw Assist Kit (K), or Total Ration Grain Tank Kit (TR)

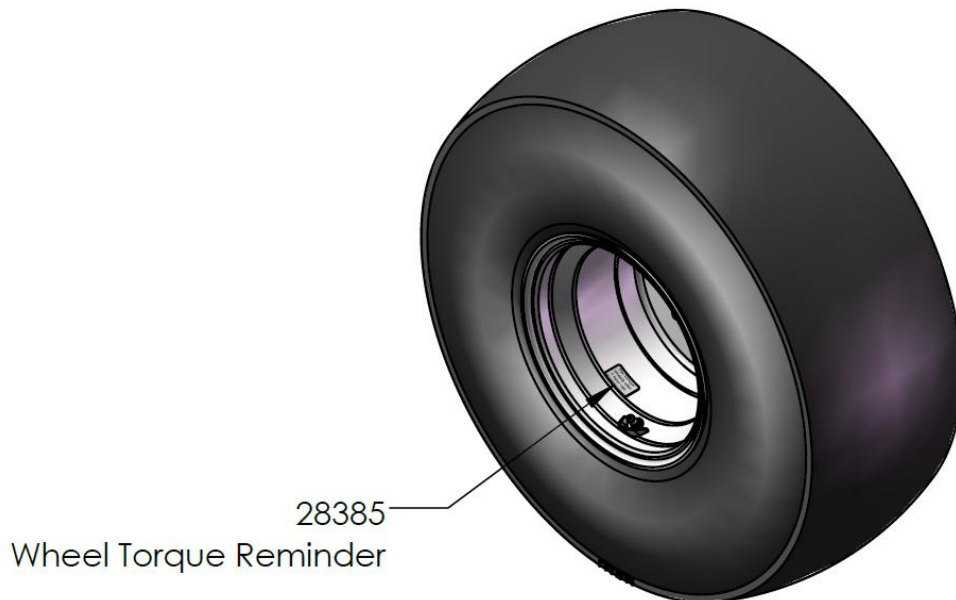

# REMOTES	OPTIONS	ID #
3 Remote		33137
2 Remote		33138
4 Remote	1	33140
3 Remote	1	33139
2 Remote	1	33138
4 Remote	2	33142
-	X/K	36144
3 Remote	2	33141
-	X/K	36145
4 Remote	3	36146
3 Remote	3	33141

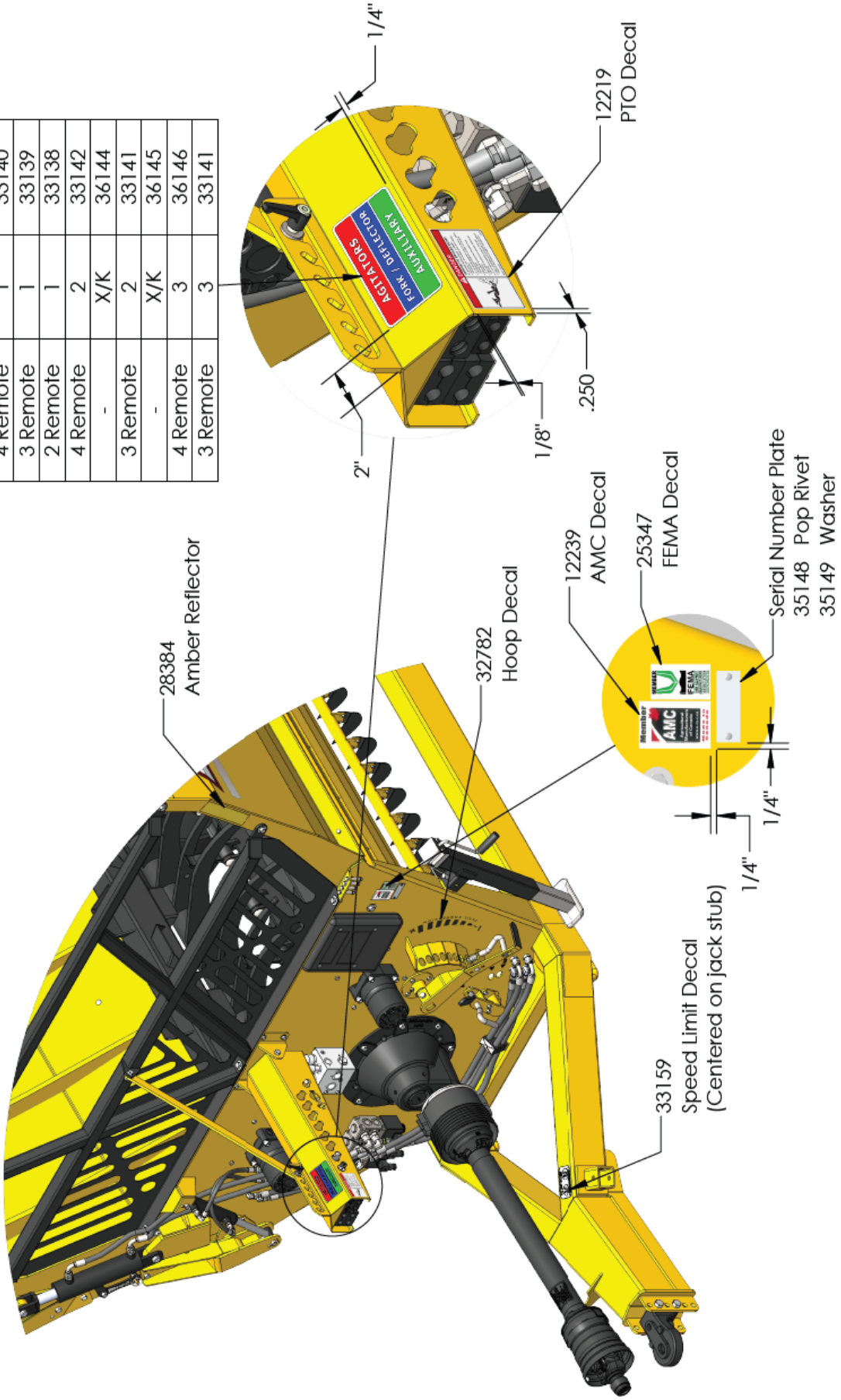

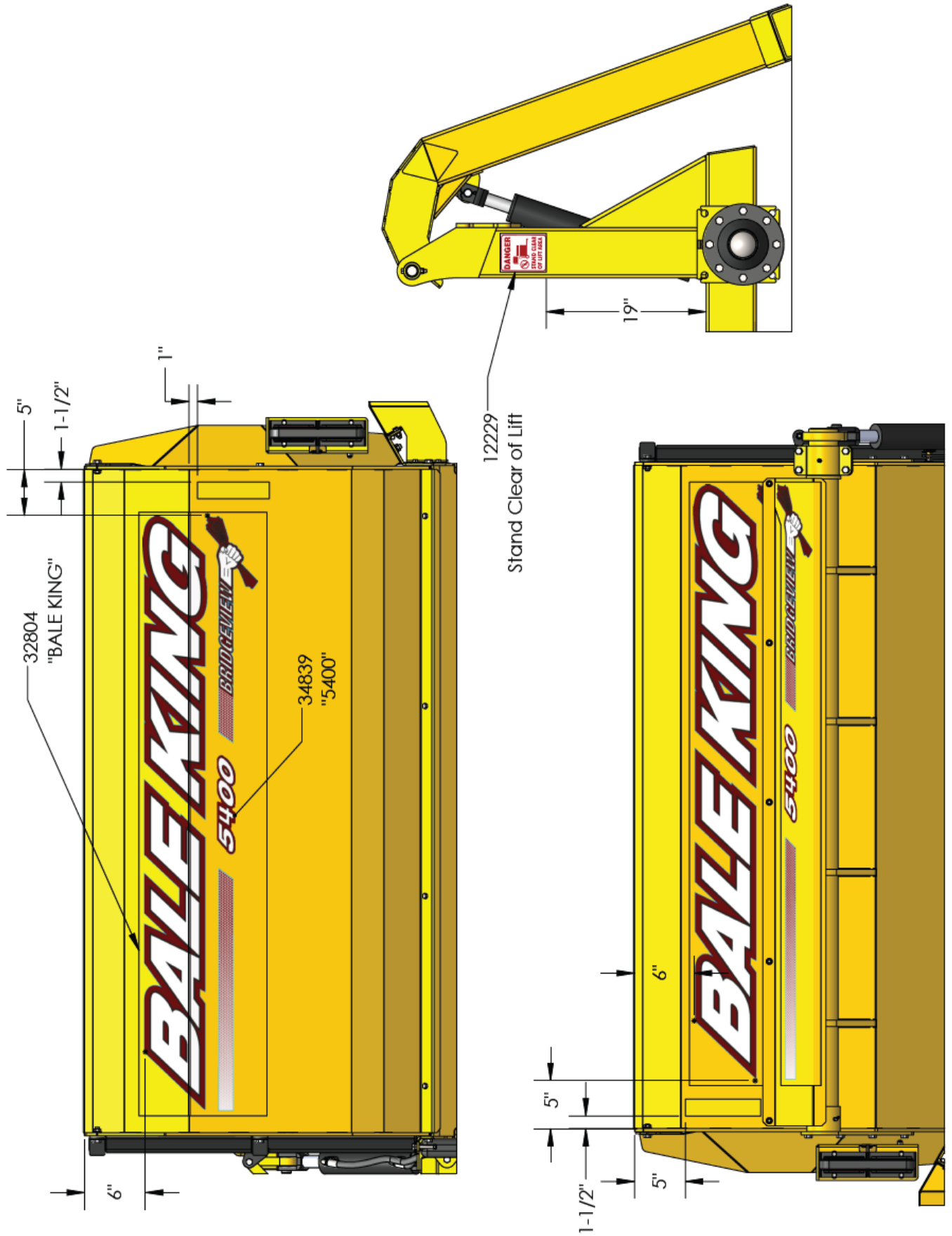

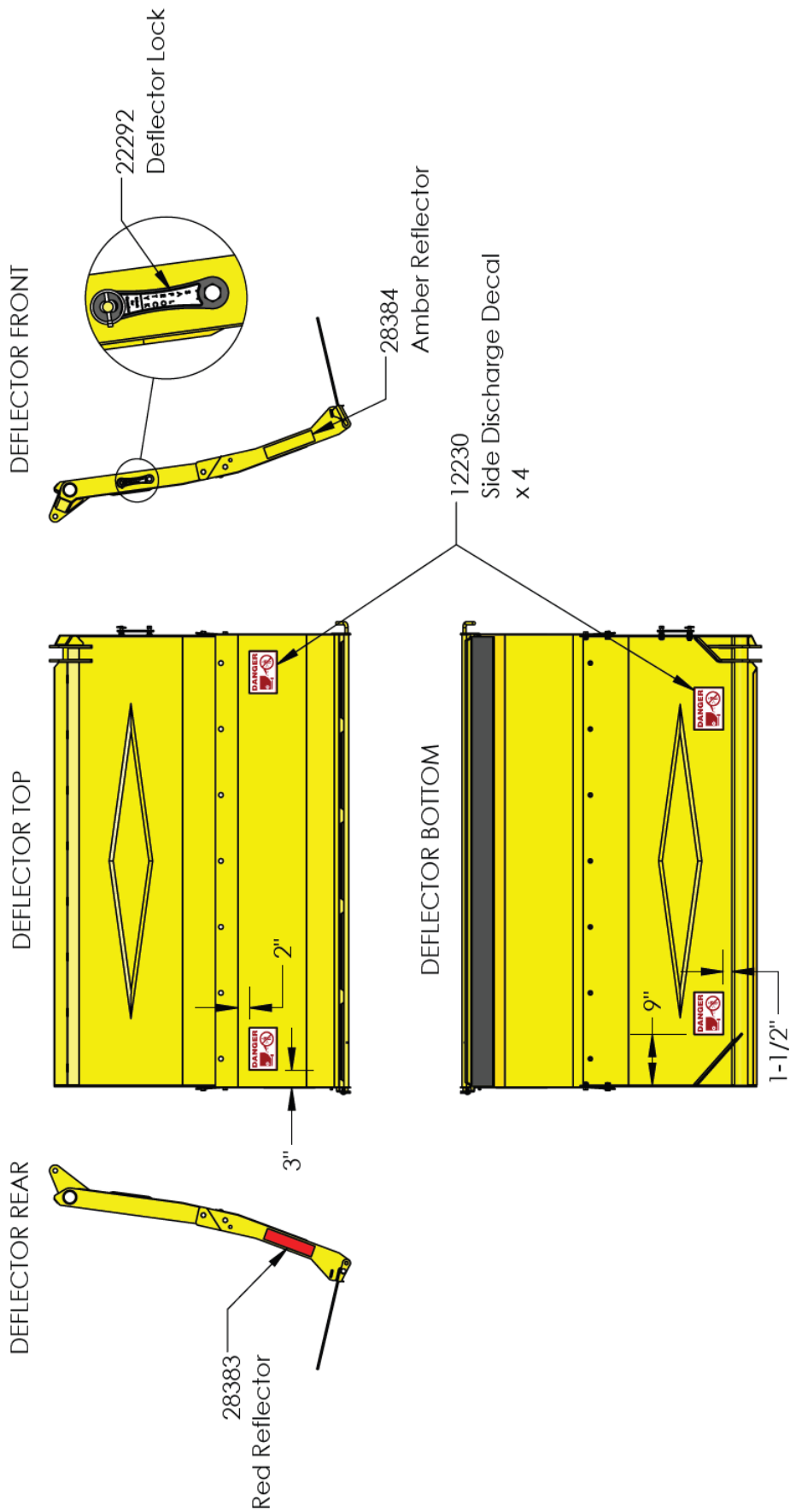

Slow Moving Vehicle (SMV) Sign Kit

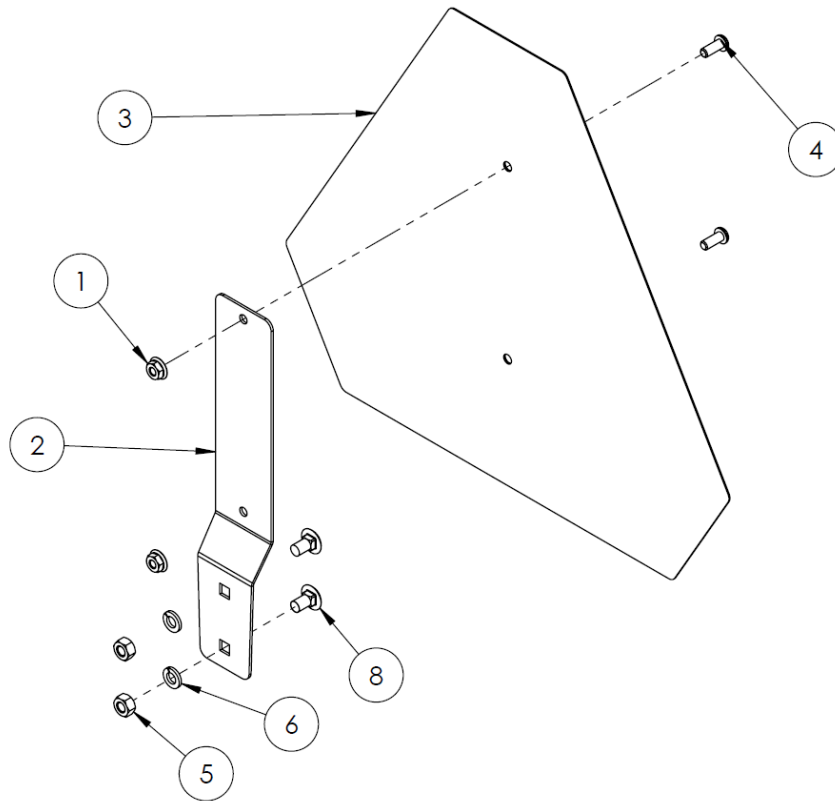

NOTE: Only the parts shown above are used on the Bale King 5400. Additional parts are included in the SMV sign kit which are not required.

#	DESCRIPTION	PART #	QTY
	Complete SMV Sign Kit	36030	1
1	Nut, 1/4" Serrated Flange	-	2
2	Galvanized Sign Bracket	-	1
3	Galvanized SMV Sign	-	1
4	Pan Head Bolt, 1/4" x 5/8"	-	2
5	Nut, 5/16"	-	2
6	Lock Washer, 5/16"	-	2
7	Galvanized Tapered Receiver Bracket	-	-
8	Carriage Bolt, 5/16" x 1/2"	-	2
9	Carriage Bolt, 5/16" x 2"	-	-
10	Lock Washer, 1/4"	-	-

Three Bale Kit Option

See table pg. 77

Three Bale Kit Left Arm

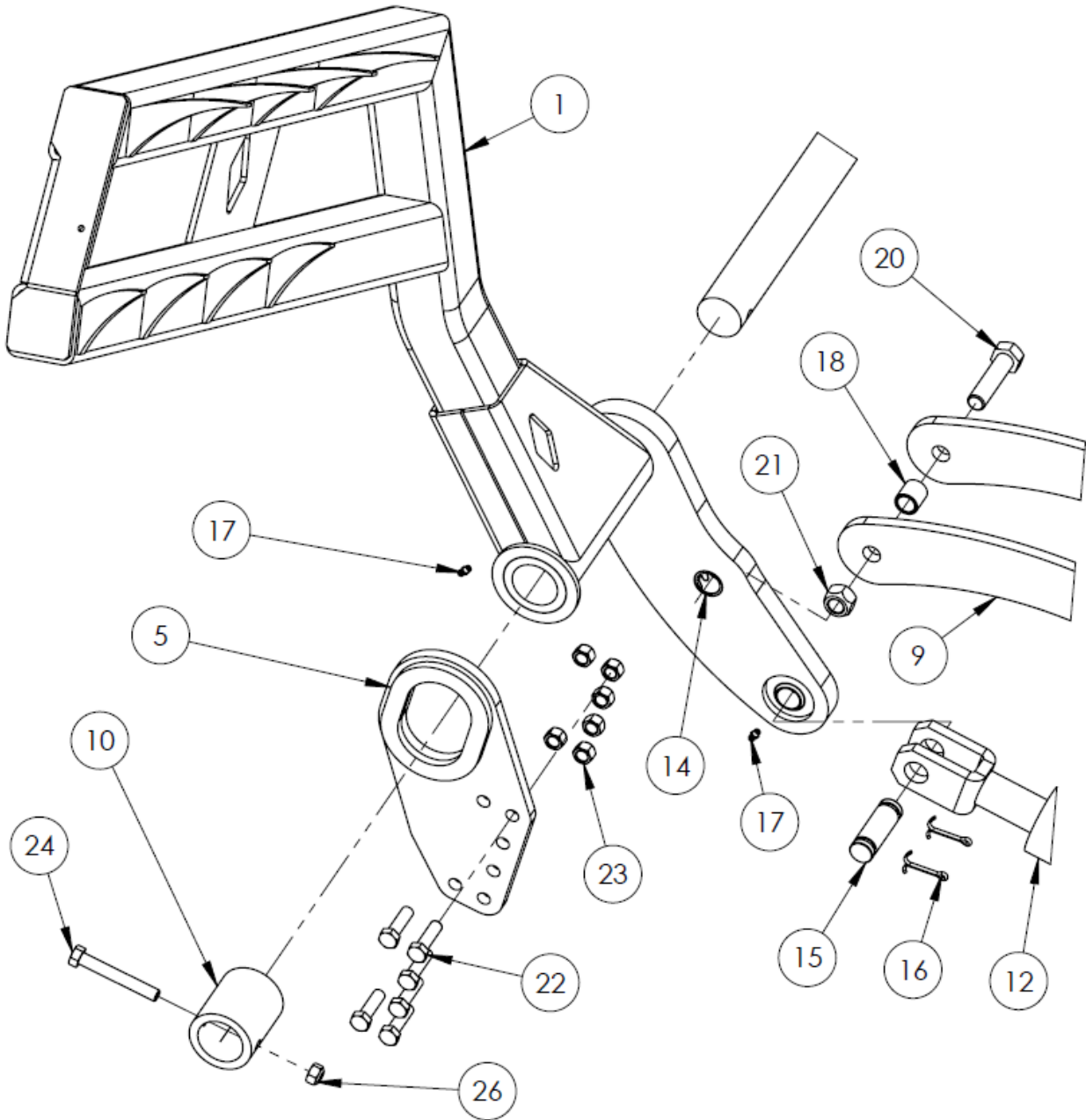

Three Bale Kit Center

See table pg. 77

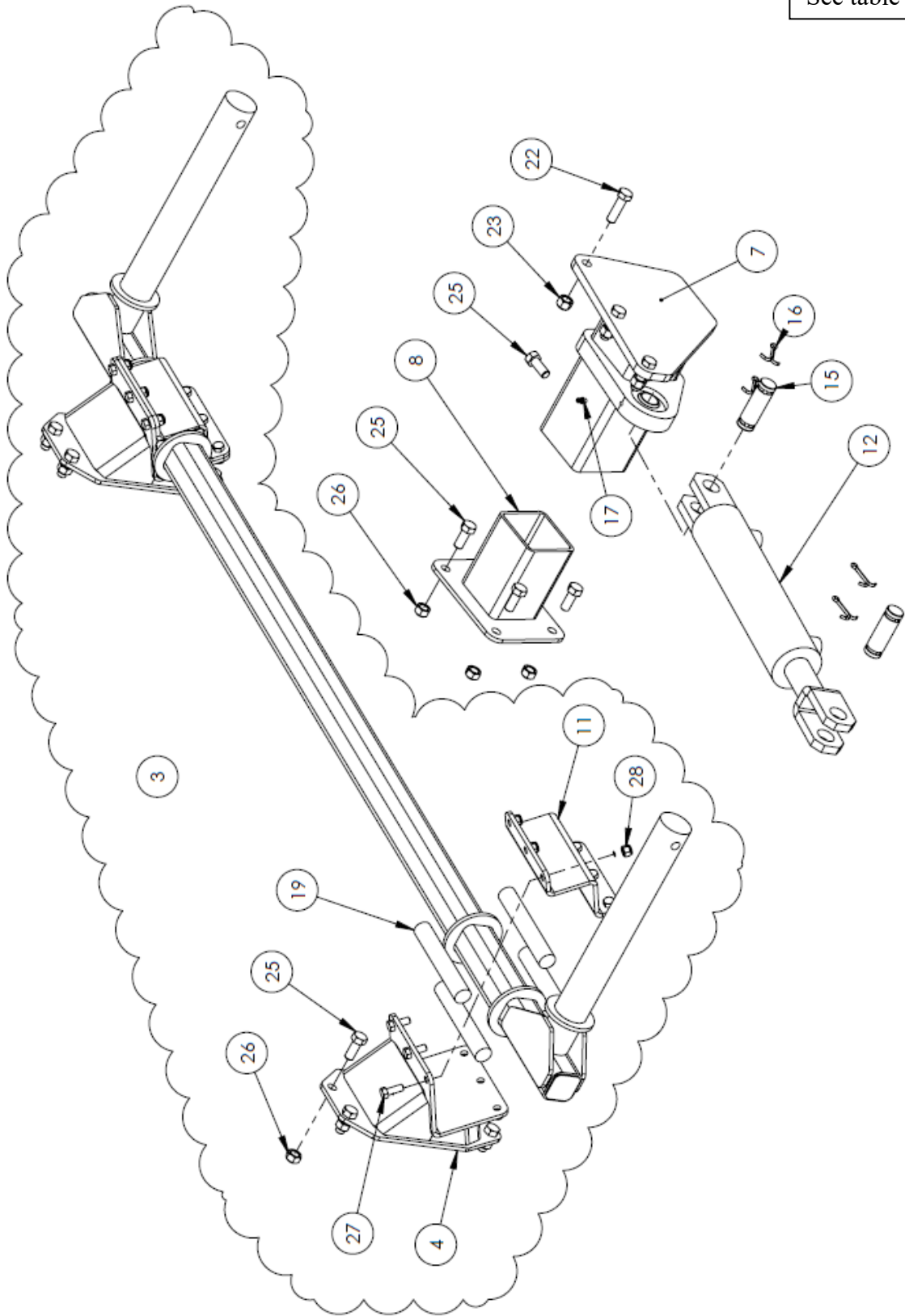

Three Bale Kit Right Arm

See table pg. 77

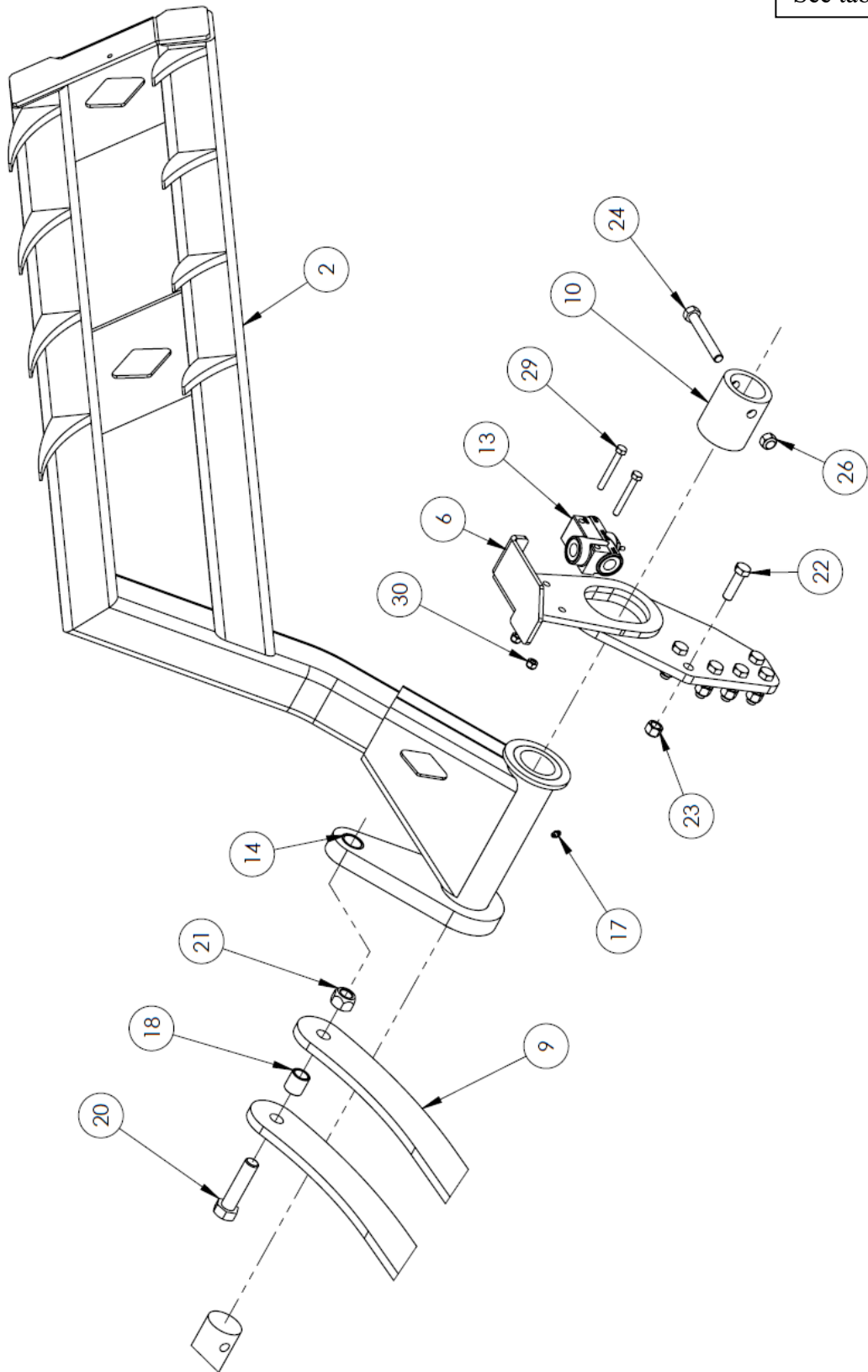



Three Bale Kit

#	DESCRIPTION	PART #	QTY
1	Left Arm	33328	1
2	Right Arm	33329	1
3	Torsion Bar Assembly * Individual parts not sold separately. Assembly not recommended *	33926	1
4	Torsion Bar Mount	NSS	2
5	Rear Support Left	33332	1
6	Rear Support Right	33333	1
7	Cylinder Base Mount	33334	1
8	Cylinder Mount Tub Adaptor	36142	1
9	Timing Bar	33335	2
10	Shaft Rear Bushing	33336	2
11	Torsion Clamp	NSS	2
12	Hydraulic Cylinder, 2-1/2" x 8" * Seal kit	Comes with pins 15 30126 17609	1
13	Depth Control Valve	30980	1
14	Press-in Bushing, 1"	23708	2
15	Cylinder Pin, 1 x 3-1/8"	10339	2
16	Cotter Pin, 3/16 x 1-1/2"	10072	4
17	Grease Zerk, 1/4"	16364	4
18	Bushing, 1" OD x 3/4" ID x 1-1/16"	36138	2
19	Rubber Torsion Bar	NSS	8
20	Bolt, 3/4 x 3"	27451	2
21	Nut, 3/4" Stover Lock	11823	2
22	Bolt, 1/2 x 1-3/4" Fine Thread	32151	15
23	Nut, 1/2" Stover Lock Fine Thread	32153	15
24	Bolt, 1/2 x 3-1/2"	10353	2
25	Bolt, 1/2 x 1-1/4"	10240	12
26	Nut, 1/2" Stover Lock	20154	13
27	Bolt, 3/8 x 1"	13806	12
28	Nut, 3/8" Nylon Lock	10806	12
29	Bolt, 5/16 x 2-1/2"	19115	2
30	Nut, 5/16" Nylon Lock	11815	2

Total Ration Grain Tank Option

Total Ration Tank Front

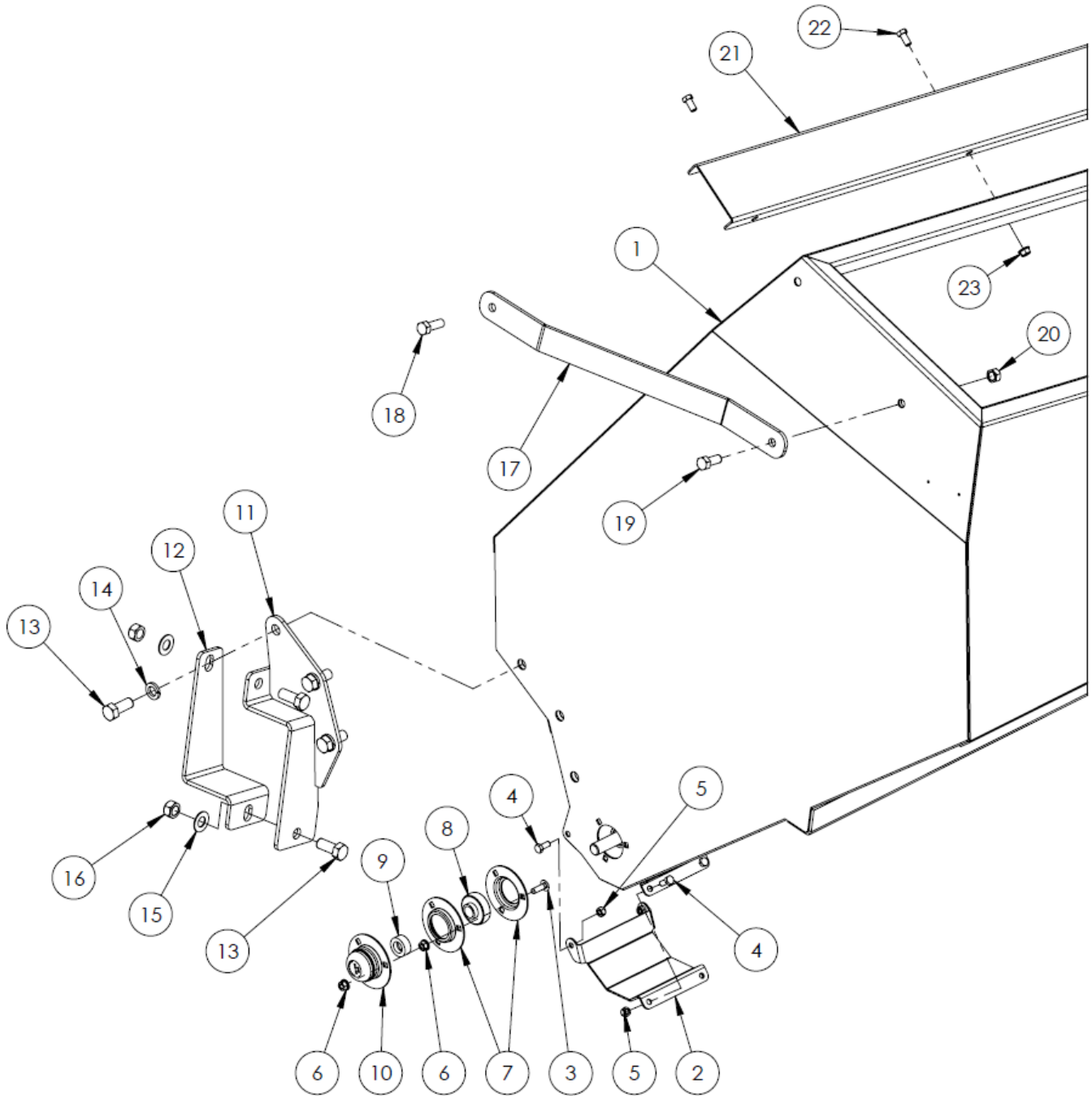

Total Ration Tank Front

#	DESCRIPTION	PART #	QTY
1	Total Ration Grain Tank	NSS	1
2	Tank Cleanout Cover	36281	1
3	Bolt, 5/16" x 1" Carriage	17884	3
4	Bolt, 5/16" x 3/4"	20903	4
5	Nut, 5/16" Nylon Lock	11815	4
6	Nut, 5/16" Serrated Flange	11814	6
7	Bearing, 3-Bolt Pressed Flange Housing	10368	2
8	Bearing, 3/4" Includes #9	10366	1
9	Bearing Lock Collar Tighten clockwise	10367	1
10	Bearing Cover	25117	1
11	5400 Front Mount Bracket	36255	1
12	5400 Front Mount Strap	30239	1
13	Bolt, 5/8" x 1-1/2"	10173	5
14	Washer, 5/8" Lock	10276	3
15	Washer, 5/8" Flat	13975	2
16	Nut, 5/8" Stover Lock	20150	2
17	Grain Tank Top Front Strap	36289	1
18	Bolt, 1/2" x 1-1/2"	10174	1
19	Bolt, 1/2" x 1"	10824	1
20	Nut, 1/2" Stover Lock	10273	1
21	Tub Seal	36310	1
22	Bolt, 3/8 x 3/4"	11816	4
23	Nut, 3/8" Serrated Flange	10271	4

Total Ration Tank Rear

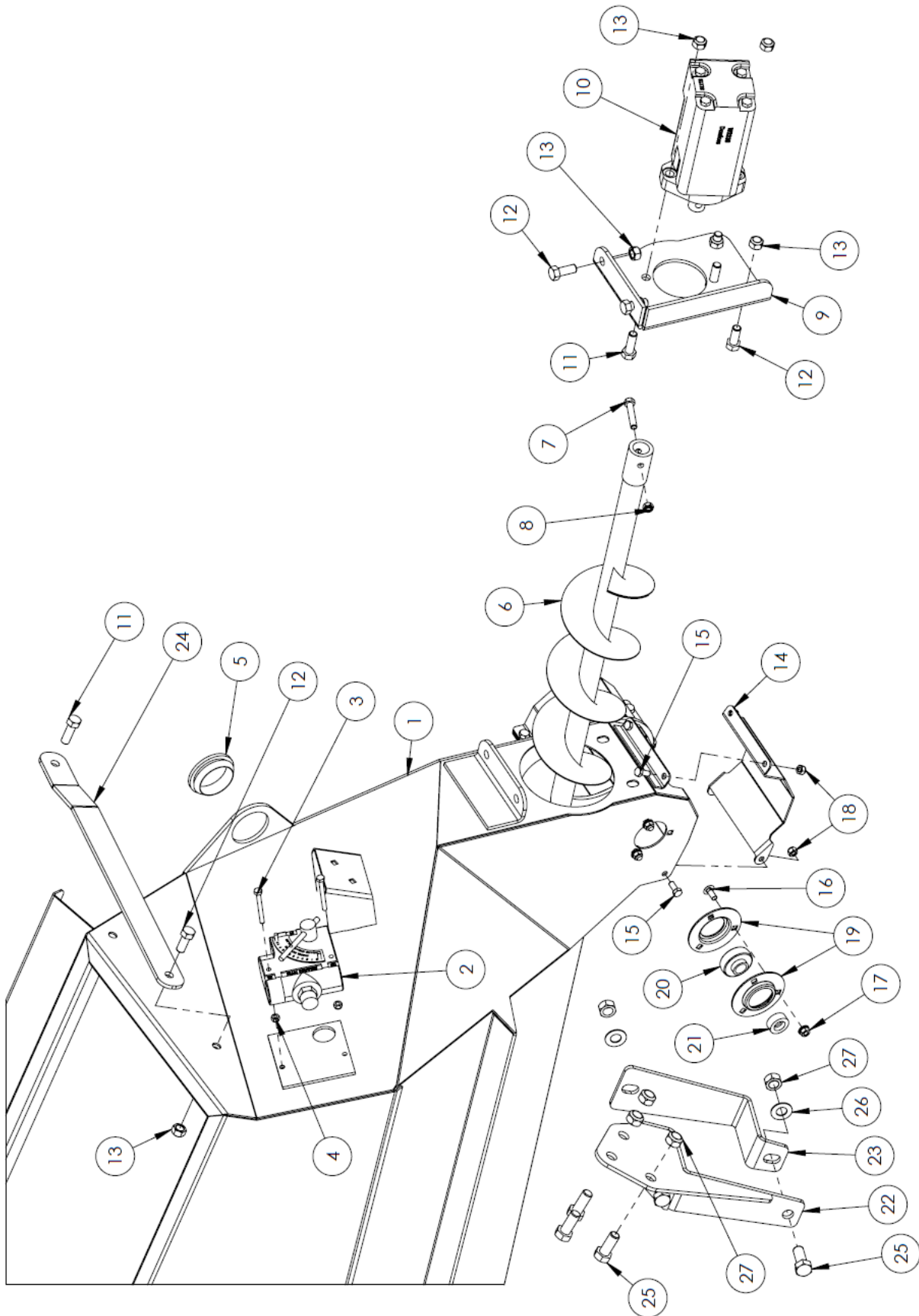

Total Ration Tank Rear

#	DESCRIPTION	PART #	QTY
1	Total Ration Grain Tank	NSS	1
2	Flow Control Valve	10455	1
3	Bolt, 1/4 x 2-3/4"	11811	2
4	Nut, 1/4" Nylon Lock	11664	2
5	Grommet, 2-1/4" ID	16397	1
6	Tank Auger	30175	1
7	Bolt, 3/8" x 2"	10279	1
8	Nut, 3/8" Stover Lock	17586	1
9	Tank Motor Mount	30233	1
10	Tank Motor, WS230	31172	1
11	Bolt, 1/2 x 1-1/2"	10174	3
12	Bolt, 1/2 x 1-1/4"	10240	5
13	Nut, 1/2" Stover Lock	20154	7
14	Cross Auger Cleanout Cover	36278	1
15	Bolt, 5/16 x 3/4"	20903	4
16	Bolt, 5/16 x 3/4" Carriage	11662	3
17	Nut, 5/16" Serrated Flange	11814	3
18	Nut, 5/16" Nylon Lock	11815	4
19	Bearing, 3-Bolt Pressed Flange Housing	10368	2
20	Bearing, 3/4" Includes #21	10366	1
21	Bearing Lock Collar Tighten clockwise	10367	1
22	5400 Rear Mount Bracket	36257	1
23	5400 Rear Mount Strap	30245	1
24	Grain Tank Top Front Strap	36291	1
25	Bolt, 5/8" x 1-1/2"	10173	5
26	Washer, 5/8" Flat	13975	2
27	Nut, 5/8" Stover Lock	20150	5

Total Ration Cross Auger

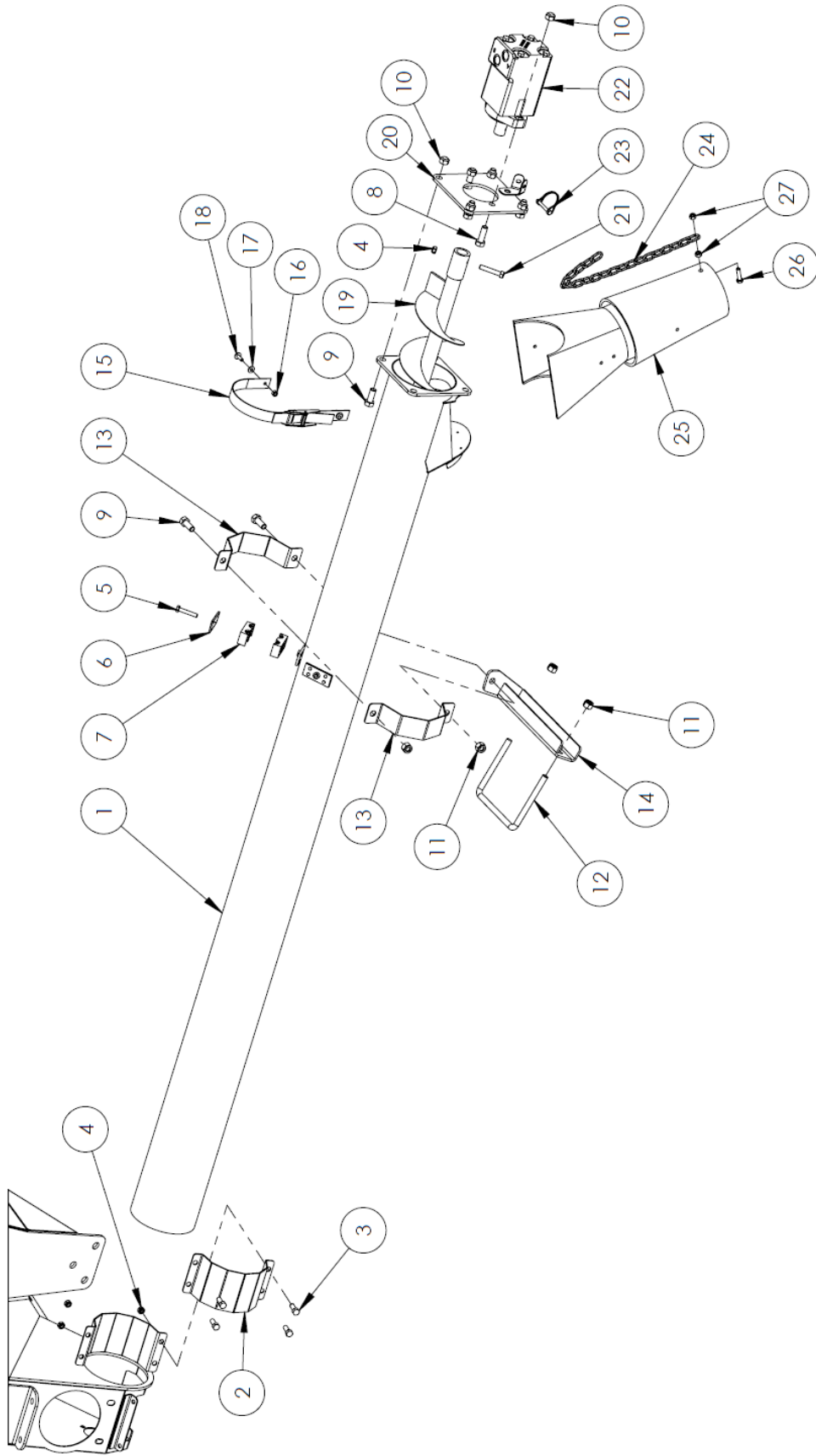

Total Ration Cross Auger

#	DESCRIPTION	PART #	QTY
1	Cross Auger Pipe	30179	1
2	Cross Auger Half Clamp	30401	1
3	Bolt, 3/8" x 1"	13806	4
4	Nut, 3/8" Stover Lock	17586	5
5	Bolt, 5/16" x 1-3/4"	21726	1
6	Hydraulic Hose Clamp Cap, Large	21715	1
7	Hydraulic Hose Clamp, 1/2"	21561	2
8	Bolt, 1/2" x 1-1/2"	10174	2
9	Bolt, 1/2" x 1-1/4"	10240	6
10	Nut, 1/2" Stover Lock	20154	6
11	Nut, 1/2" Nylon Lock	10241	4
12	U-Bolt, 1/2 x 6 x 5"	25056	1
13	Cross Auger Support Clamp	36298	2
14	Cross Auger Support Bar	36265	1
15	Spout Strap	Includes both parts 25122	1
16	Nut, 1/4" Nylon Lock	11664	2
17	Washer, 1/4" Flat	14448	2
18	Bolt, 1/4" x 3/4" Truss Head	17638	2
19	Cross Auger	30169	1
20	Cross Auger Motor Mount	30194	1
21	Bolt, 3/8" x 2"	10279	1
22	Cross Auger Motor, WS080	30132	1
23	Lock Pin, 1/4" x 1.25"	13951	1
24	Chain, 3/16" x 20 links	25121	1
25	Auger Spout	30149	1
26	Bolt, 5/16" x 1-1/4"	24418	1
27	Nut, 5/16" Nylon lock	11815	2

Total Ration Tank Lid

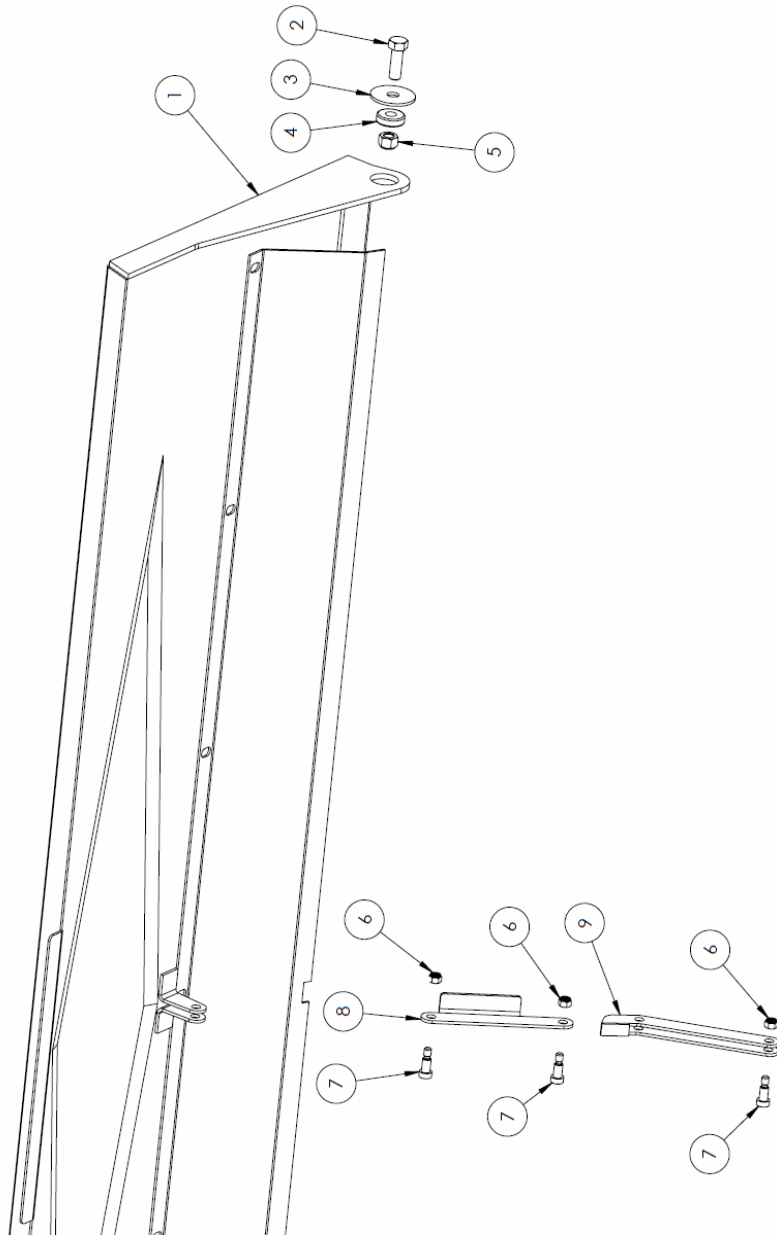

#	DESCRIPTION	PART #	QTY
1	Grain Tank Lid	30165	1
2	Bolt, 1/2" x 1-1/4"	10240	2
3	Washer, 1/2" Fender	10238	2
4	Bushing, 1/2" ID x 1.250" OD	10239	2
5	Nut, 1/2" Stover Lock	20154	2
6	Nut, 5/16" Nylon Lock	11815	3
7	Bolt, 3/8" x 5/8" Shoulder	30466	3
8	Lid Upper Support	30163	1
9	Lid Lower Support	30166	1

Fine Chop Option

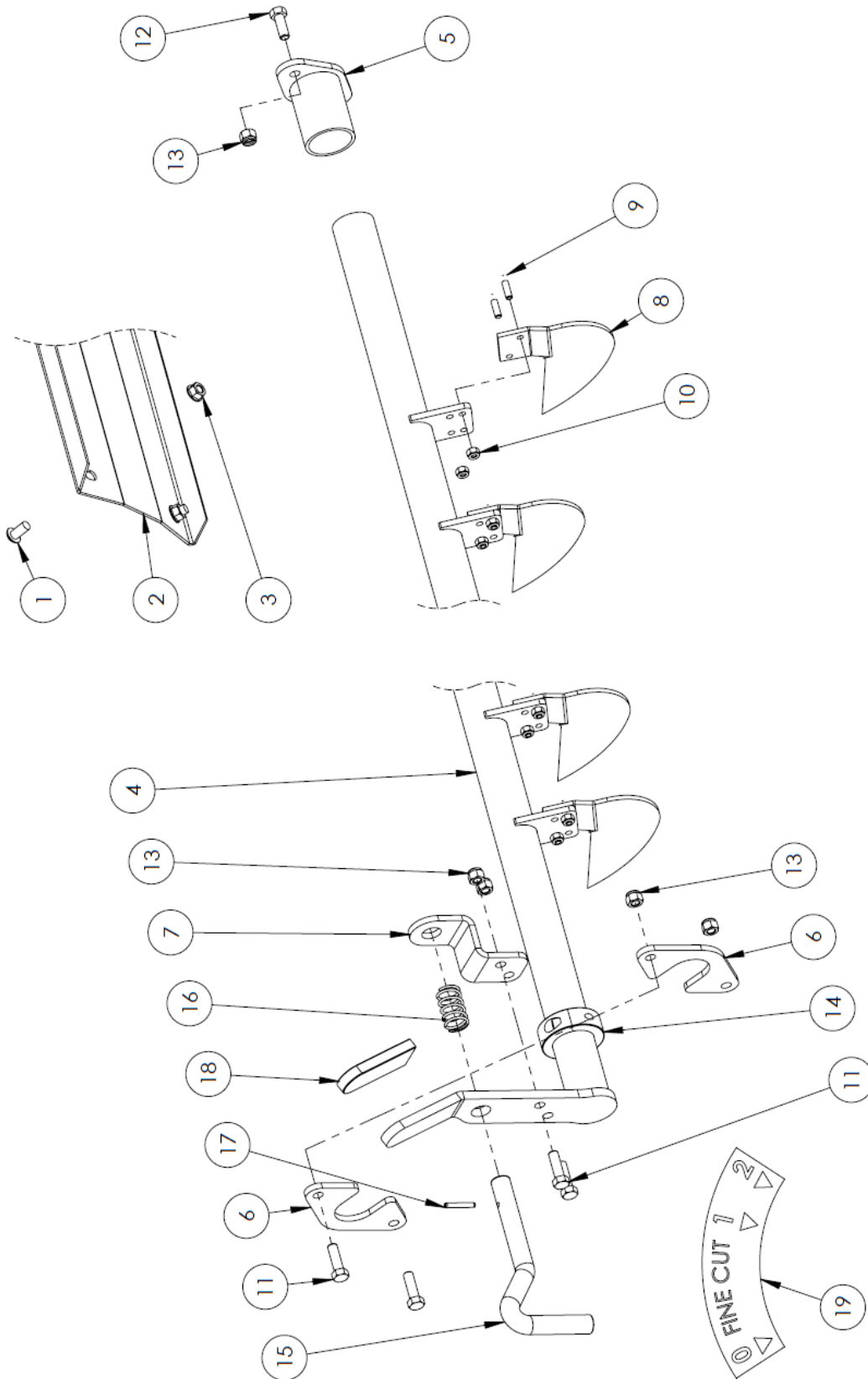



Fine Chop Option

#	DESCRIPTION	PART #	QTY
	Fine Chop Cover * IF NO FINE CHOP INSTALLED *		
1	Fin Bolt, 3/8" x 3/4"	10807	8
2	Fine Chop Cover Plate	36040	1
3	Nut, 3/8" Serrated Flange	11818	8
	Fine Chop Kit * Optional *	36155	1
4	Fine Chop Bar	36164	1
5	Fine Chop Mount Rear	22444	1
6	Fine Chop Front Mount	36163	2
7	Fine Chop Spring Mount	36161	1
8	Fine Chop Knife	10404	13
9	Bolt, 1/4" x 3/4"	11809	26
10	Nut, 1/4" Nylon Lock	11664	26
11	Bolt, 3/8 x 1-1/4"	10253	4
12	Bolt, 3/8" x 1"	13806	2
13	Nut, 3/8" Nylon Lock	10806	6
14	Split Collar	12792	1
15	S-Handle	22187	1
16	Compression Spring	34465	1
17	Roll Pin, 3/16 x 1-1/4"	10302	1
18	Rubber Handle	10297	1
19	Decal, Fine Chop	36031	1

Optional Rotary Straw Assist "Kicker" Kit

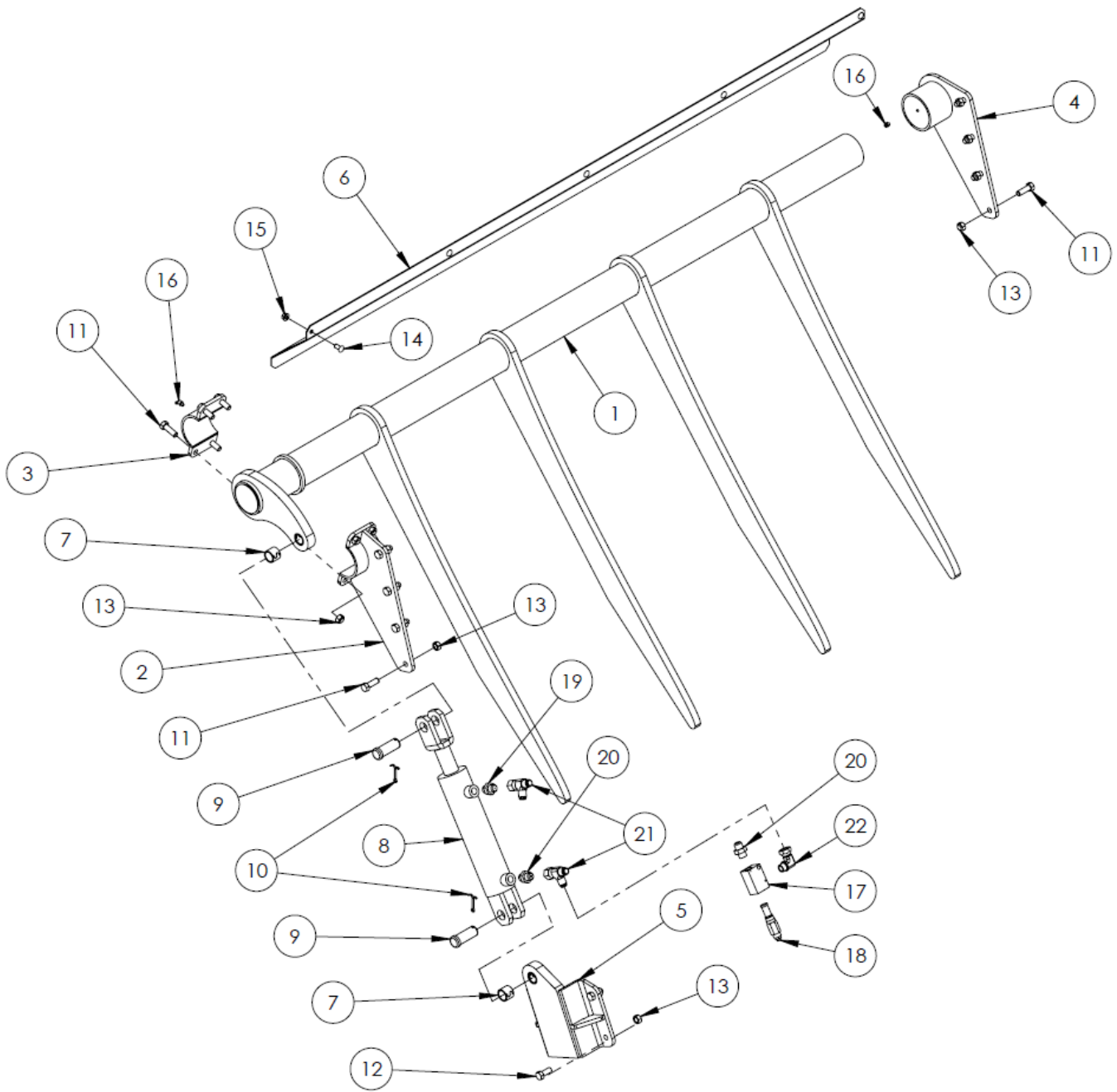



Rotary Straw Assist Kit

#	DESCRIPTION	PART #	QTY
	Rotary Straw Assist Kit	36193	-
1	Bale Kicker	36217	1
2	Bale Kicker Front Pivot	36219	1
3	Bale Kicker Pivot Clamp	36223	1
4	Bale Kicker Rear Pivot	36221	1
5	Bale Kicker Cylinder Bracket	36225	1
6	Bale Kicker Outside Cover	36214	1
7	Press-in Bushing, 1"	23708	2
8	Hydraulic Cylinder, 2-1/2 x 8" * Seal Kit	30126 17609	1
9	Cylinder Pin, 1 x 2-1/4" Usable	36027	2
10	Cotter Pin, 3/16 x 1-1/2"	10072	2
11	Bolt, 1/2 x 1-1/2"	10174	12
12	Bolt, 1/2 x 1-1/4"	10240	4
13	Nut, 1/2" Stover Lock	14393	16
14	Bolt, 3/8 x 3/4" Fin	10807	5
15	Nut, 3/8" Serrated Flange	10271	5
16	Grease Zerk, 1/4" x 45°	20888	2
17	Relief Valve Body	36371	1
18	Relief Valve, 400 psi	36370	1
19	Hyd. Fitting, 8MB – 8MJ (.062 Orifice)	36033	1
20	Hyd. Fitting, 8MB – 8MJ	10561	2
21	Hyd. Fitting, 8FJXR – 8MJT	11768	2
22	Hyd. Fitting, 8MB – 8FJX90	36369	1

Back-up Camera Option

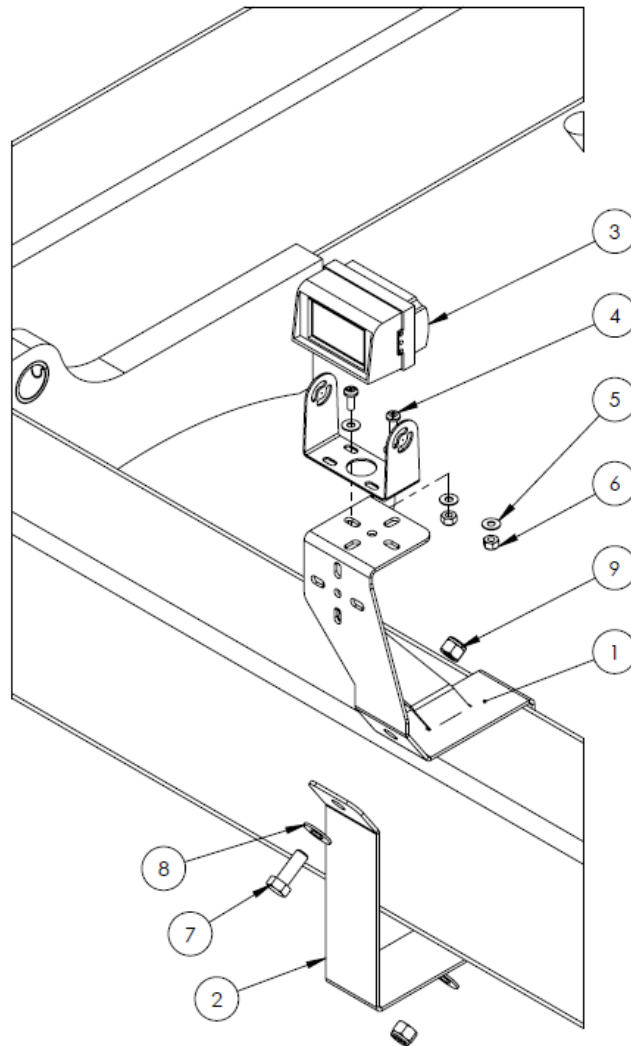

#	DESCRIPTION	PART #	QTY
	Complete Back-up Camera Kit - Standard	32619	-
	Complete Back-up Camera Kit - Pro	32628	-
1	Camera Mounting Bracket	32618	1
2	Camera Mounting Strap	32617	1
3	* Back-up Camera – Standard	32640	1
	* Back-up Camera – Pro	32639	
4	Bolt, #10 x 1/2"	17035	2
5	Washer, #10 Flat	25600	4
6	Nut, #10 Nylon Lock	31110	2
7	Bolt, 3/8 x 1"	13806	2
8	Washer, 3/8" Flat	11667	4
9	Nut, 3/8" Nylon Lock	10806	2
10	Extension Cable, 15'	32645	1
11	Grommet, 5/16" ID x 1/4"	13179	2

***NOTE: Camera package comes with camera bracket, monitor, and harnesses**



HYDRAULIC SCHEMATICS

HYDRAULIC COMPONENTS	91
HYDRAULIC FITTINGS	92
HYDRAULIC HOSES.....	93
FRONT PANEL – ROLLERS	94
FRONT PANEL – 3-REMOTE	95
FRONT PANEL – 2-REMOTE	96
FRONT PANEL – THREE BALE KIT – 4-REMOTE	97
FRONT PANEL – THREE BALE KIT – 3-REMOTE	98
FRONT PANEL – THREE BALE KIT – 2-REMOTE	99
FRONT PANEL – TOTAL RATION – 4-REMOTE.....	100
FRONT PANEL – TOTAL RATION – 3-REMOTE.....	101
FRONT PANEL – TOTAL RATION – 2-REMOTE.....	102
FRONT PANEL – KICKER – 4-REMOTE	103
FRONT PANEL – KICKER – 3-REMOTE	104
FRONT PANEL – KICKER – 2-REMOTE	105
FRONT PANEL – THREE BALE CLAMP & TOTAL RATION – 4-REMOTE.....	106
FRONT PANEL – THREE BALE CLAMP & TOTAL RATION – 3-REMOTE.....	107
FRONT PANEL – KICKER & THREE BALE CLAMP – 4-REMOTE.....	108
FRONT PANEL – KICKER & THREE BALE CLAMP – 3-REMOTE.....	109
FRONT PANEL – KICKER & TOTAL RATION – 4-REMOTE.....	110
FRONT PANEL – KICKER & TOTAL RATION – 3-REMOTE.....	111
FRONT PANEL – 3 OPTION – 4-REMOTE	112
FRONT PANEL – 3 OPTION – 3-REMOTE	113
REAR FORK	114
REAR FORK AND THREE BALE KIT.....	115
TR GRAIN TANK KIT	116

HYDRAULIC COMPONENTS

#	DESCRIPTION	PART #
AA	Hydraulic Cylinder - 3 x 18 x 1.5"	Rear Forks
	* Seal Kit	21717
	* Replacement Shaft	20807 31034
BB	Hydraulic Cylinder – 2.5 x 8 x 1.5"	3 Bale Kit Arms
	* Seal Kit	Kicker 30126 17609
CC	Hydraulic Cylinder - 1.5 x 6 x 1"	Deflector
	* Seal Kit	21711 23738
DD	Hydraulic Motor – RE750	Rollers
	* Seal Kit	25872 25891
EE	Hydraulic Motor – WS230	Tank Auger
FF	Hydraulic Motor – WS080	Cross Auger
GG	Flow Divider Valve	Rollers
HH	Diverter Valve	
	* Nut & O-Ring	11743 17977
	* Magnet	11789
	* Stack Kit	12895
	*Triple Stack Kit	12897
II	Pilot-operated Check Valve	Fork, Deflector
JJ	Check Valve, 8MJ-8FB	Grain Tank
KK	Depth Control Valve	3 Bale Kit Arms
LL	Flow Control Valve	Grain Tank
MM	Pioneer Tip, 8FB	
NN	Hose Marker, Long Red	
OO	Hose Marker, Short Red	
PP	Hose Marker, Long Blue	
QQ	Hose Marker, Short Blue	
RR	Hose Marker, Long Yellow	
SS	Hose Marker, Short Yellow	
TT	Hose Marker, Long Green	
UU	Hose Marker, Short Green	
VV	Relief Valve, 400 psi	Kicker
	Valve Body	36370 36371

NOTE: Quantities vary depending on machine set-up. Order as required.



HYDRAULIC FITTINGS

#	DESCRIPTION	PART #
F1	12MB-8MJ90	22174
F2	10MB-8MJ90	12169
F3	10MB-8MJ45	23844
F4	10MB-8MJ	10161
F5	10MB-6MJ90	12168
F6	10MB-6MJ45	22722
F7	10MB-6MJ	11739
F8	8MB-8MJ (.063 Orifice)	36033
F9	8MB-6MB90	33739
F10	8MB-6MJ90	10200
F11	8MB-6MJ	11740
F12	8MJ-8MJ	36032
F13	8MJBH	28774
F14	8MJBH90	10531
F15	8MJ-8FJX90	12166
F16	8MBR-8MJT	22159
F17	8FJXR-8MJT	11768
F18	8MB Plug	31013
F19	6MB-6MJ	10162
F20	6MB-6MJ90	10201
F21	6MBR-6MJT	23726
F22	6MBL-6MJT	27678
F23	6FJXR-6MJT	15760
F24	6MJ-6FJX90	12162
F25	6MJ-6FJX45	12160
F26	6MJBH	11767
F27	6MJBH90	10187
F28	6MB-6MJ (.031 Orifice)	17436
F29	8MB-8MJ	10561
F30	8MB-8FJX90	36369

NOTE: Quantities vary depending on machine set-up. Order as required.



HYDRAULIC HOSES

#	DIA.	LENGTH	ENDS
H1	1/2"	131" OAL	8FJX-8FJX90
H2	1/2"	117" OAL	8MB-8FJX
H3	1/2"	102" OAL	8FJX-8FJX90
H4	1/2"	98" OAL	8MB-8FJX
H5	1/2"	83" OAL	8FJX-8FJX
H6	1/2"	48" OAL	8FJX-8FJX
H7	1/2"	44.5" OAL	8FJX-8FJX90
H8	1/2"	43" OAL	8FJX-8FJX
H9	1/2"	43" OAL	8FJX-8FJX90
H10	1/2"	41" OAL	8FJX-8FJX90
H11	1/2"	33" OAL	8MB-8FJX
H12	1/2"	16.5" OAL	8FJX-8FJX45
H13	3/8"	122" OAL	8MB-6FJX
H14	3/8"	117" OAL	8MB-8FJX
H15	3/8"	81" OAL	6FJX-8FJX
H16	3/8"	79.5" OAL	6FJX-6FJX
H17	3/8"	58" OAL	6FJX-6FJX
H18	3/8"	50" OAL	6FJX-6FXJ90
H19	3/8"	46" OAL	8FJX-8FJX90
H20	3/8"	38" OAL	8FJX-8FJX90
H21	3/8"	38" OAL	8FJX-8FJX
H22	3/8"	31" OAL	6FJX-6FJX90
H23	3/8"	29.5" OAL	8FJX-8FJX
H24	3/8"	27" OAL	6FJX-6FJX90
H25	3/8"	26" OAL	6FJX-6FJX45
H26	3/8"	20" OAL	6FJX-6FJX45
H27	3/8"	16" OAL	6FJX-8FJX
H28	3/8"	14.25" OAL	6FJX-8FJX
H29	3/8"	14" OAL*	6FJX-6FJX90
H30	3/8"	13.5" OAL*	6FJX-6FJX90
H31	3/8"	13" OAL	6FJX-6FJX
H32	3/8"	10.75" OAL*	6FJX-6FJX
H33a	1/4"	132" OAL	8MB-6FJX90
H33b	1/4"	126" OAL	8MB-6FJX90
H34	1/4"	26" OAL	6FJX-6FJX90
H35	1/4"	19" OAL	6FJX-6FJX90
H36	1/4"	14" OAL	6FJX-6FJX90
H37	1/4"	12" OAL	6FJX-6FJX45
H38	3/8"	9.25" OAL	8FJX-8FJX

NOTE: Quantities vary based on machine set-up. Hoses are not available for sale.

Use the information above to have replacement hoses made up locally.

All hoses should be double braid, with crimps rated for at least 3500 psi.

FRONT PANEL – ROLLERS

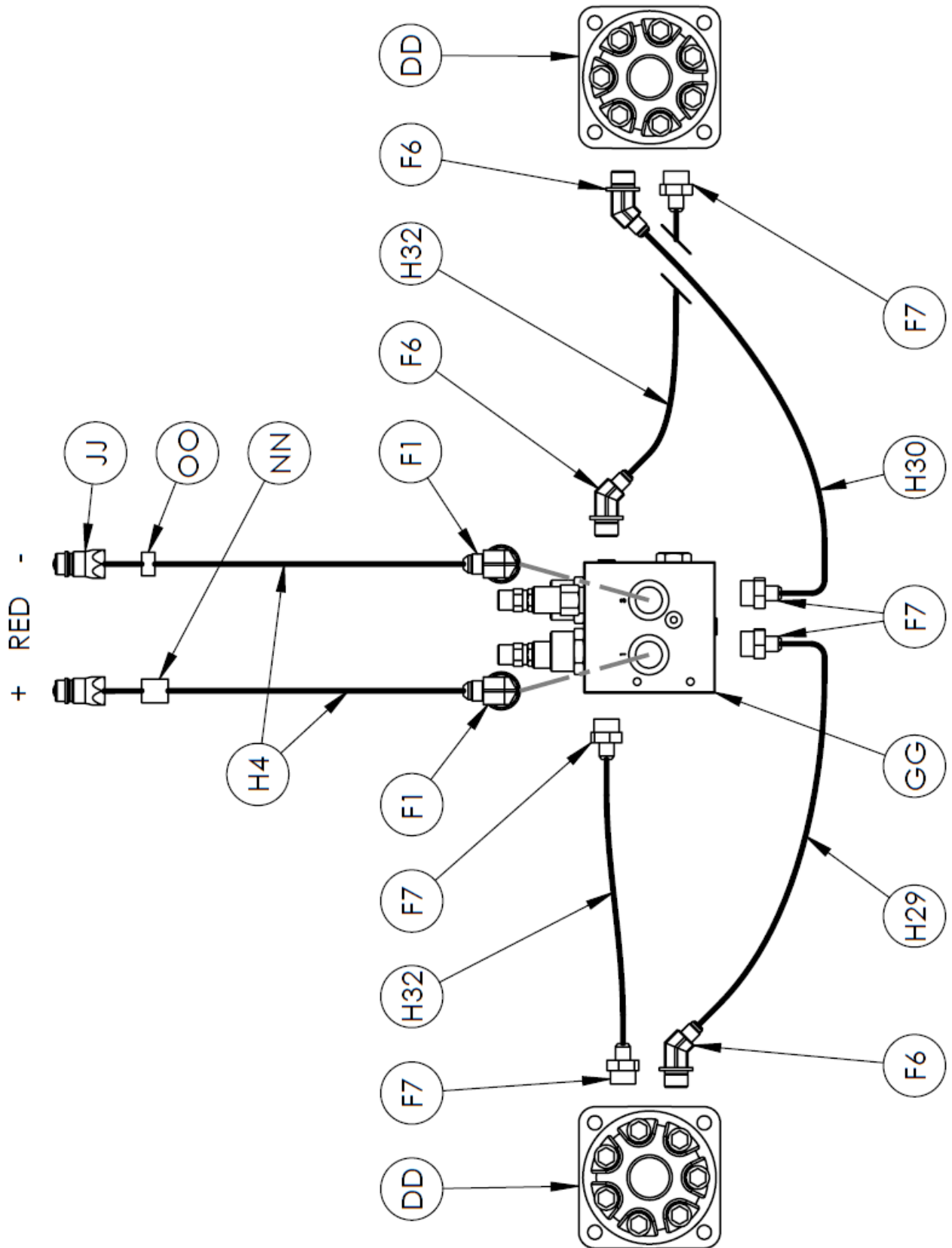

FRONT PANEL – 3-REMOTE

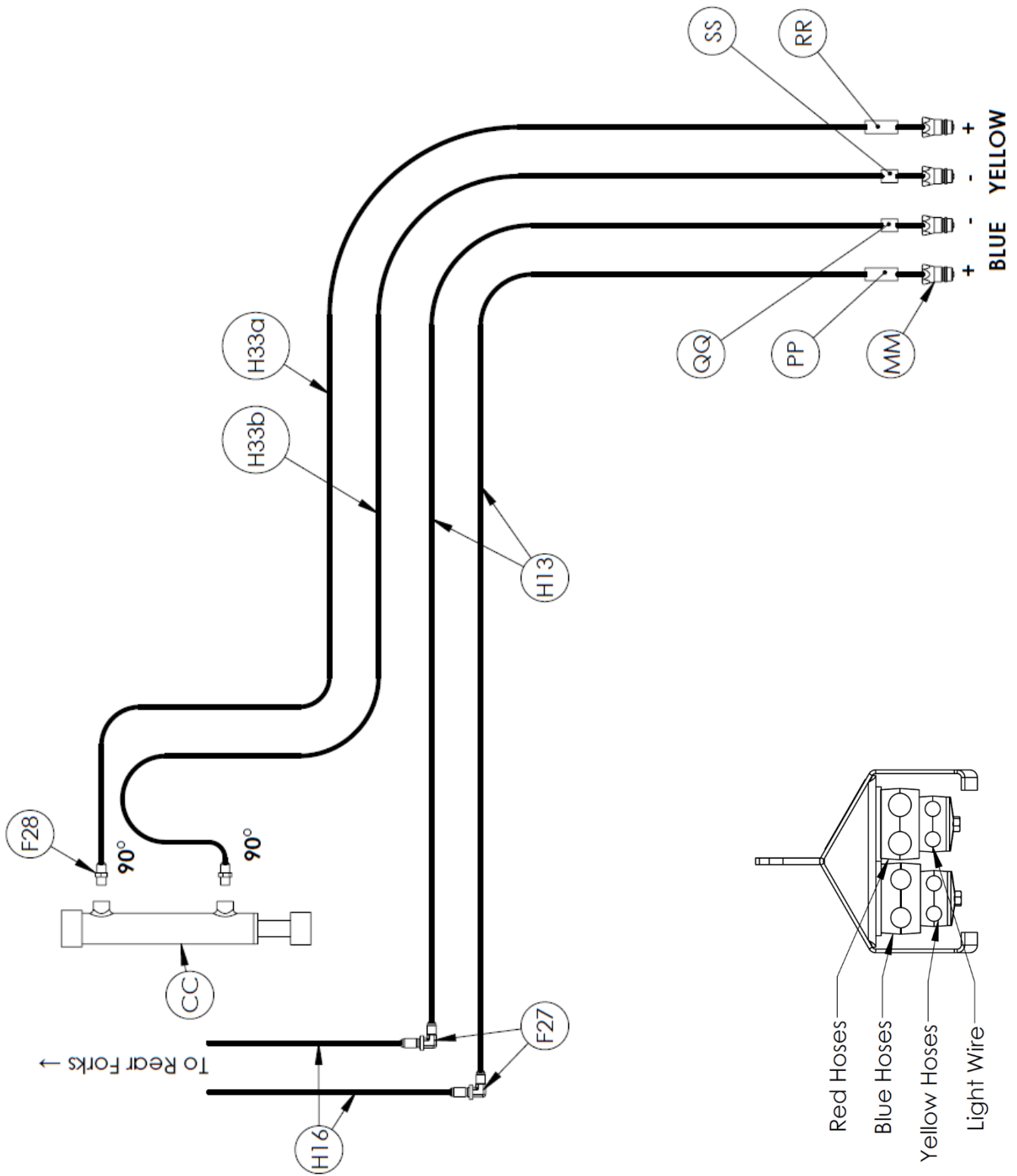

FRONT PANEL – 2-REMOTE

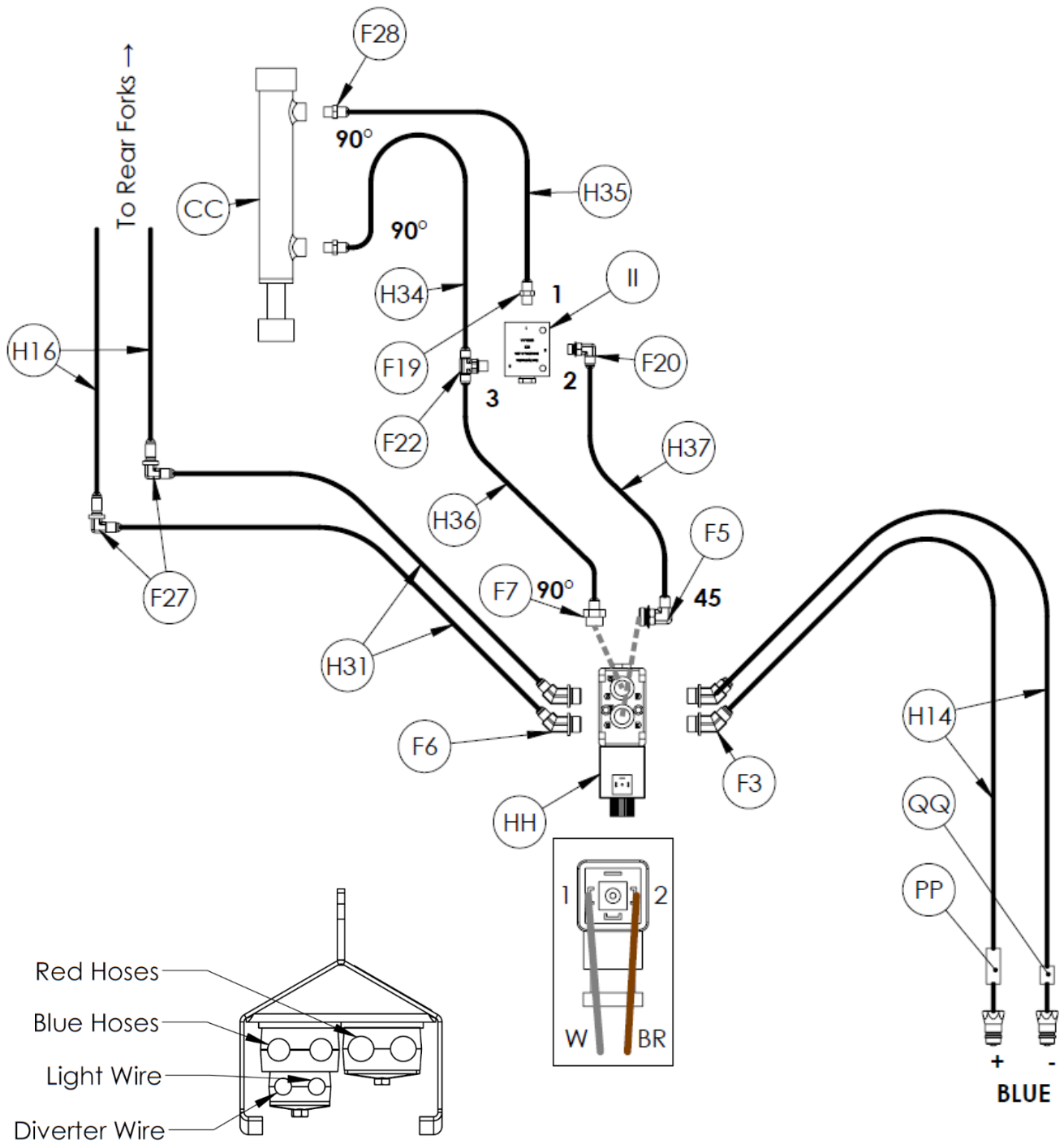

FRONT PANEL – THREE BALE KIT – 4-REMOTE

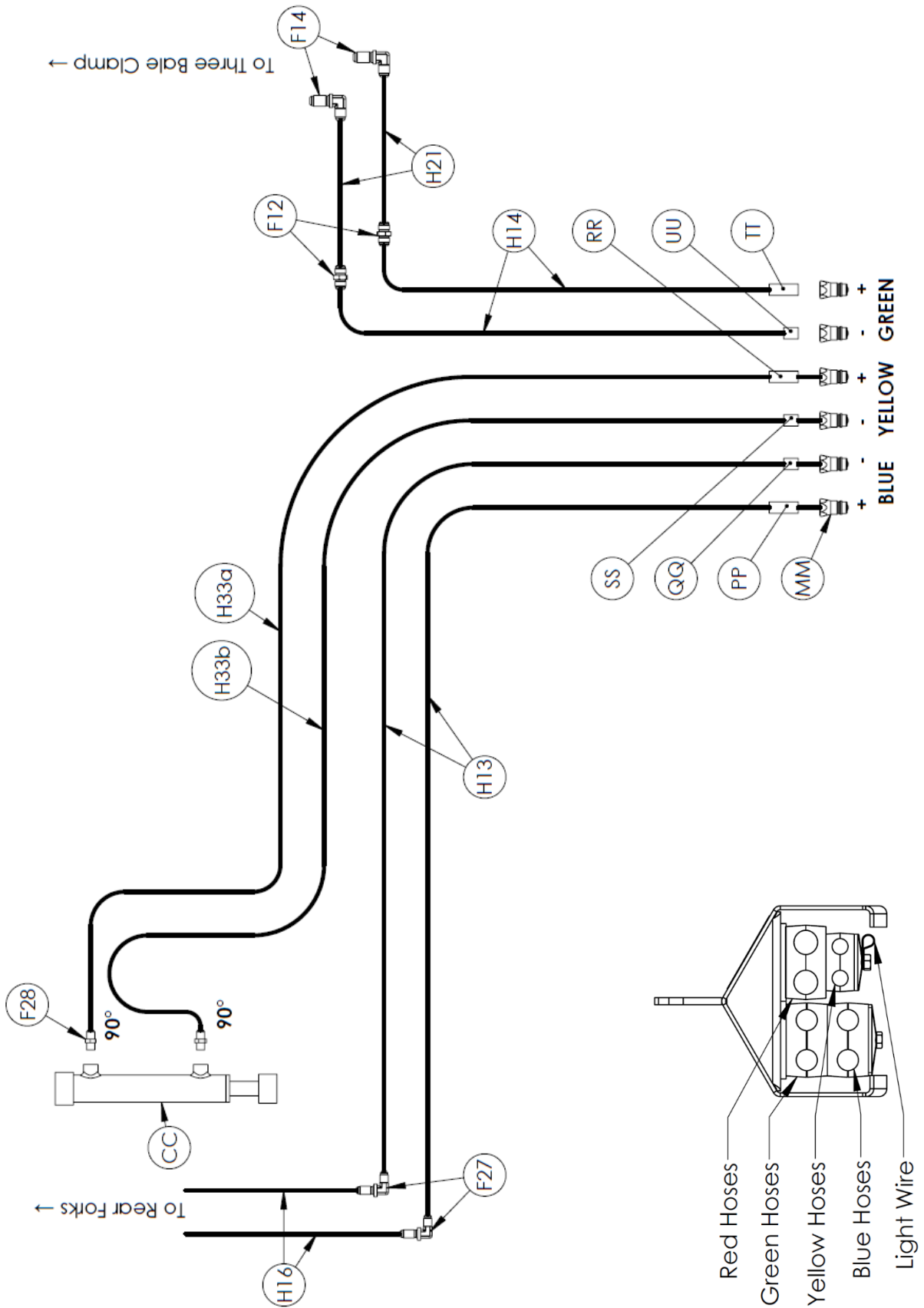

FRONT PANEL – THREE BALE KIT – 3-REMOTE

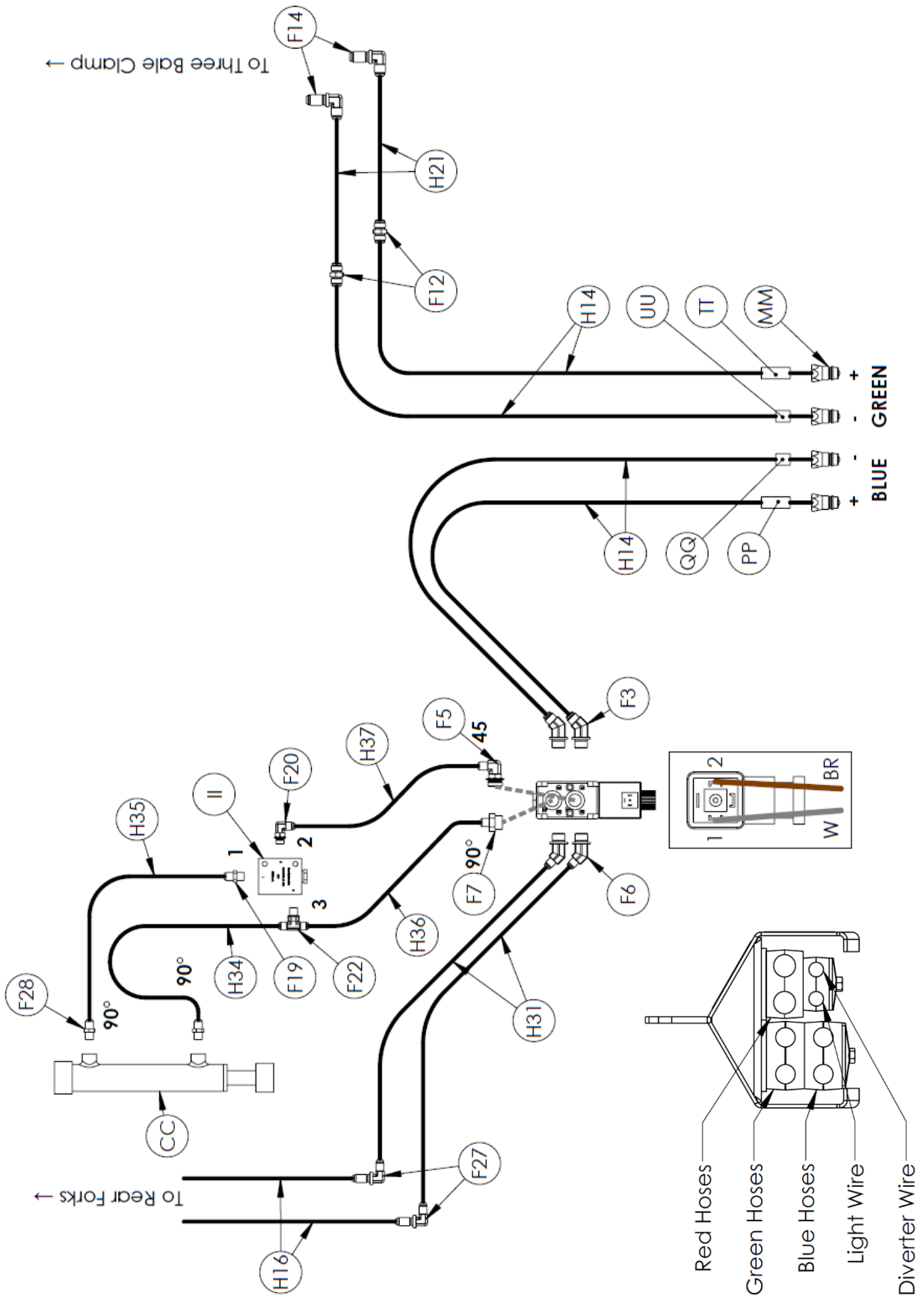

FRONT PANEL – THREE BALE KIT – 2-REMOTE

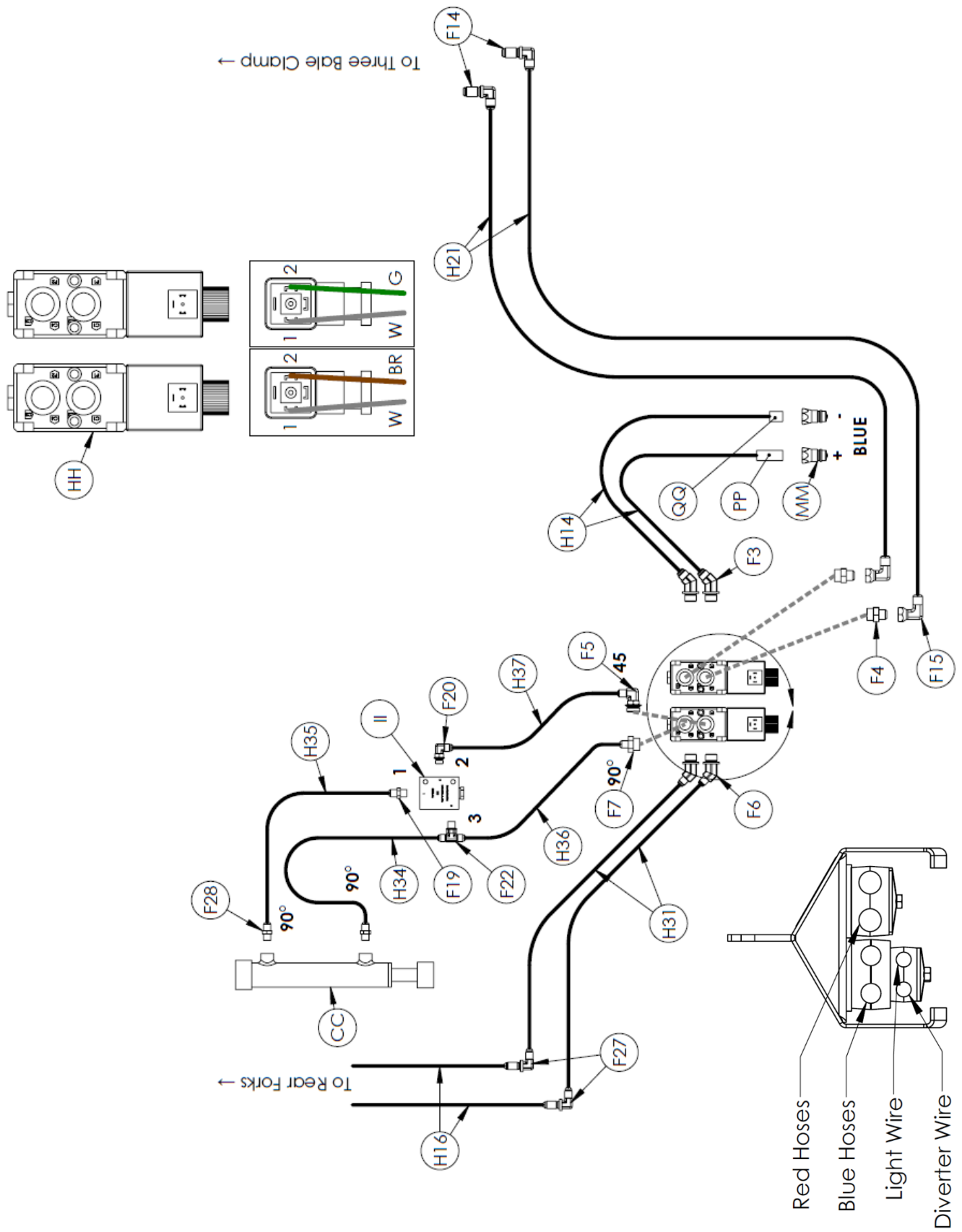

FRONT PANEL – TOTAL RATION – 4-REMOTE

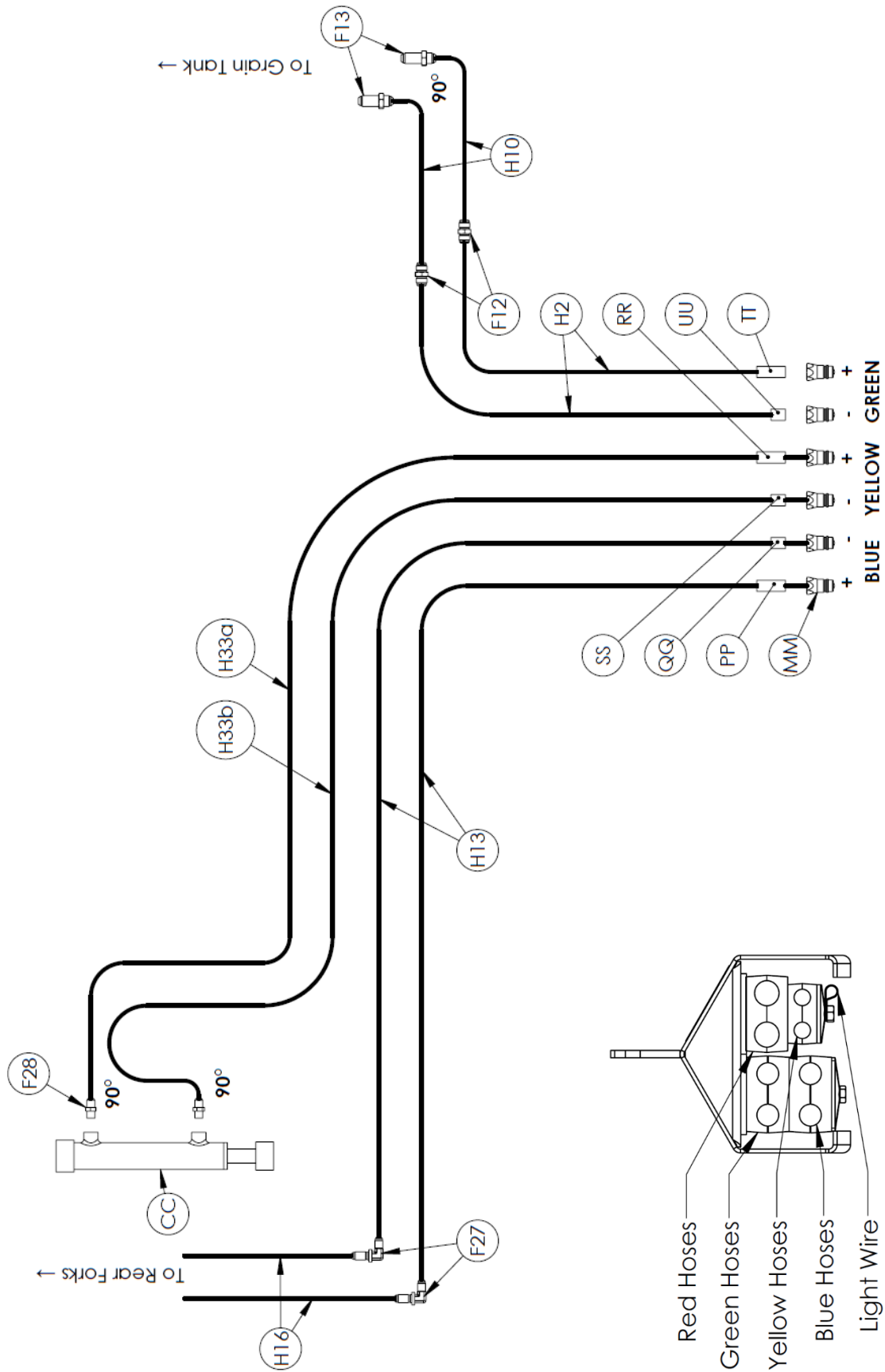

FRONT PANEL – TOTAL RATION – 3-REMOTE

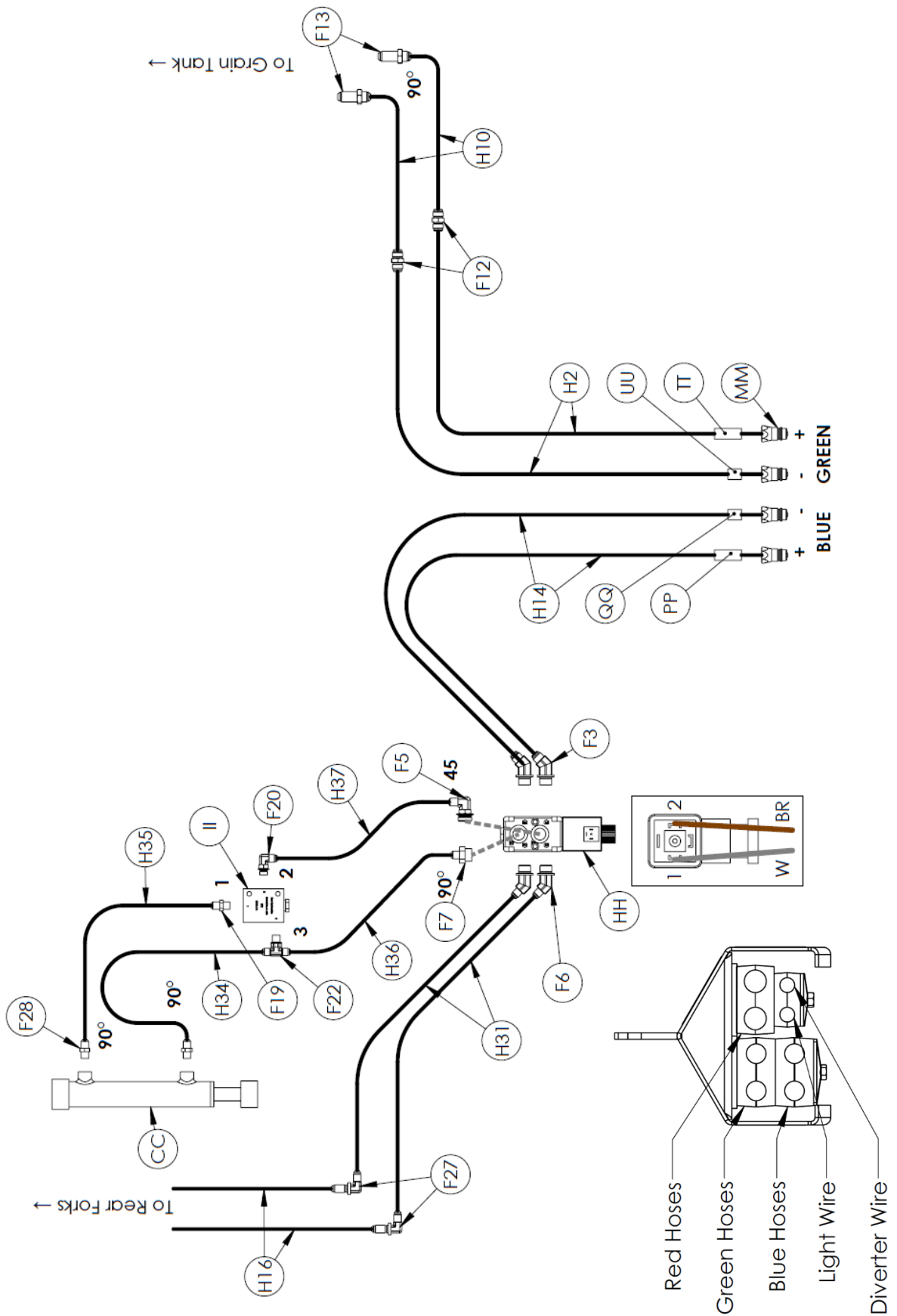

FRONT PANEL – TOTAL RATION – 2-REMOTE

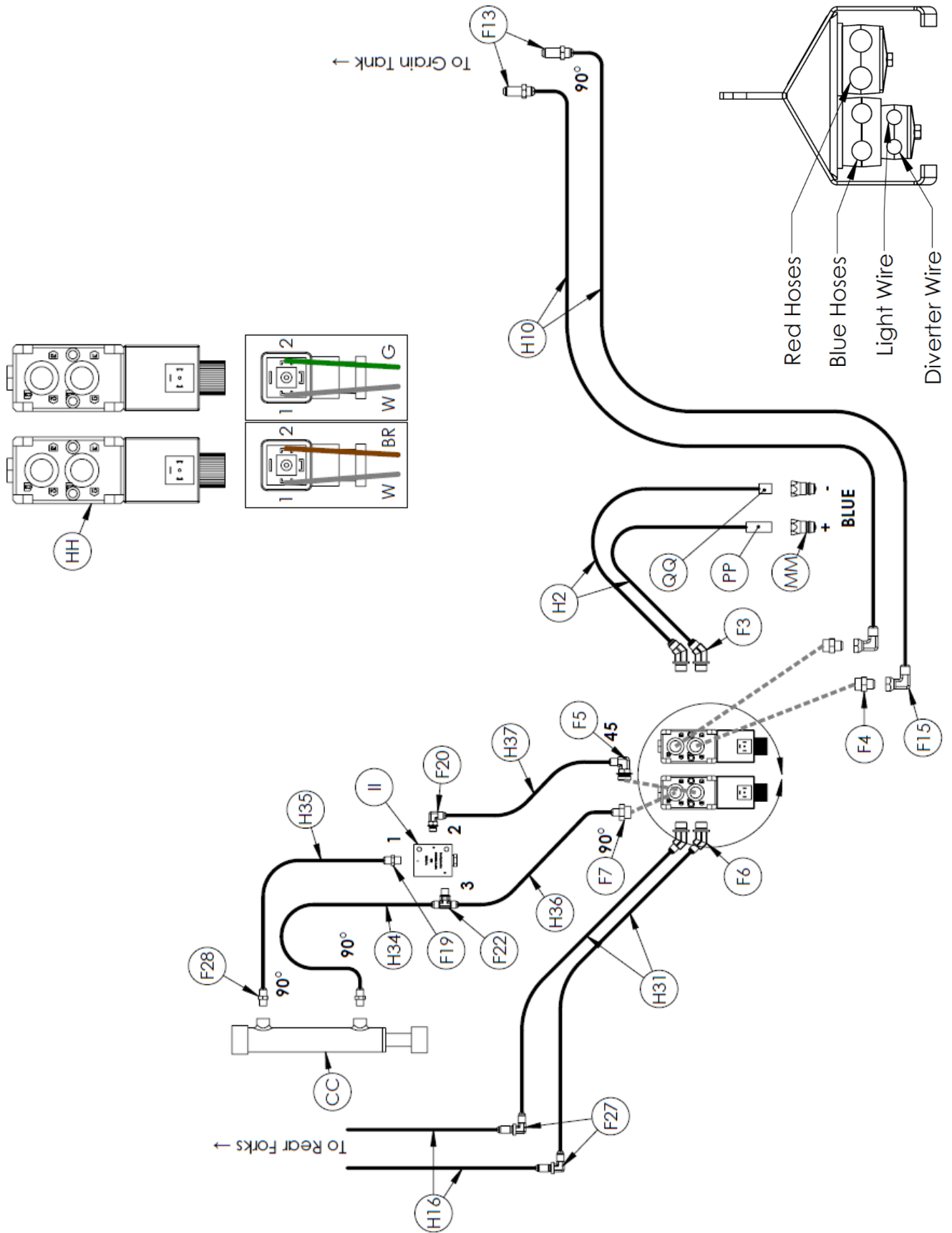

FRONT PANEL – KICKER – 4-REMOTE

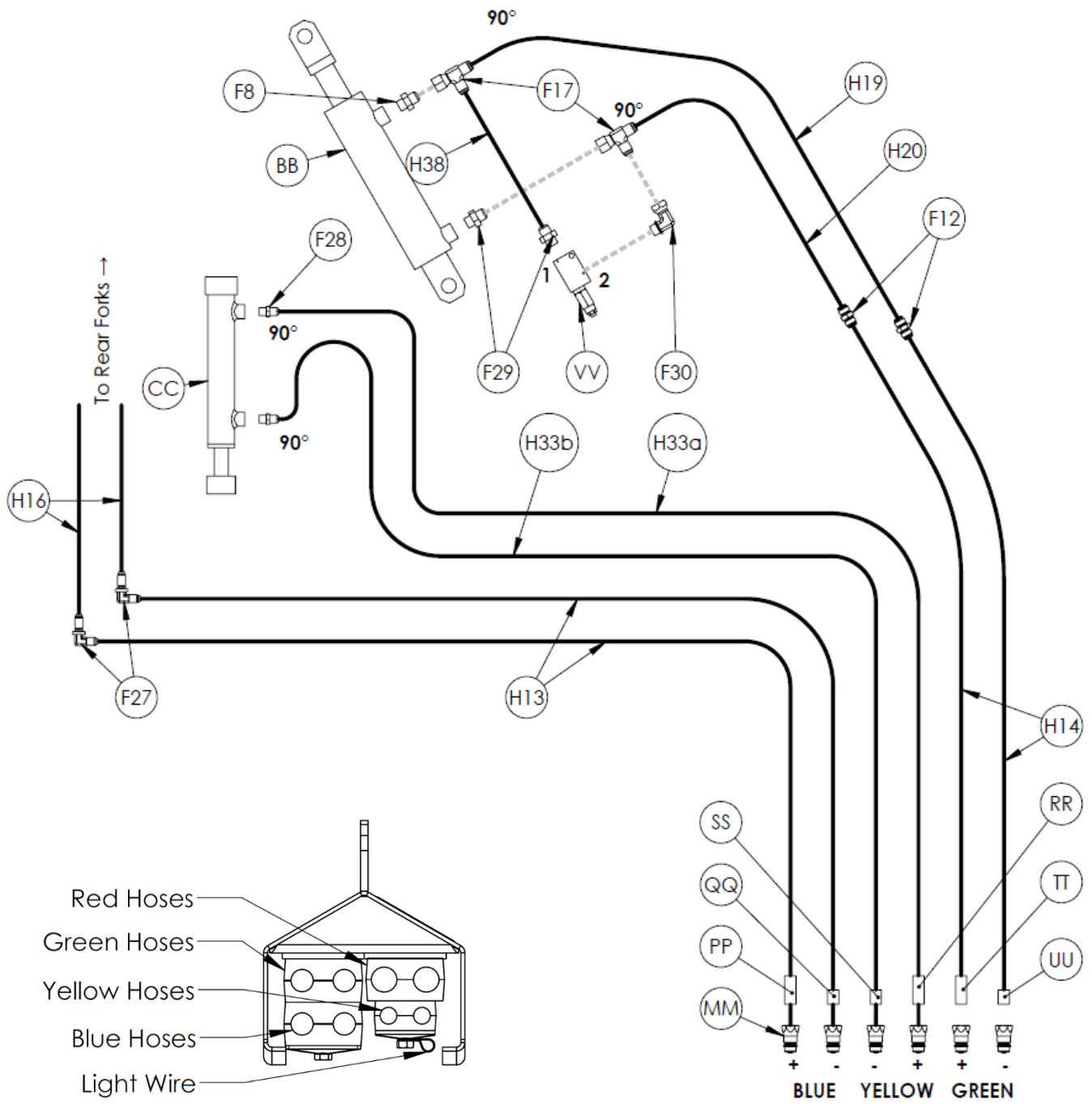

FRONT PANEL – KICKER – 3-REMOTE

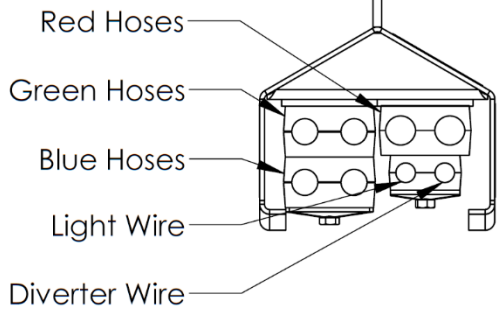
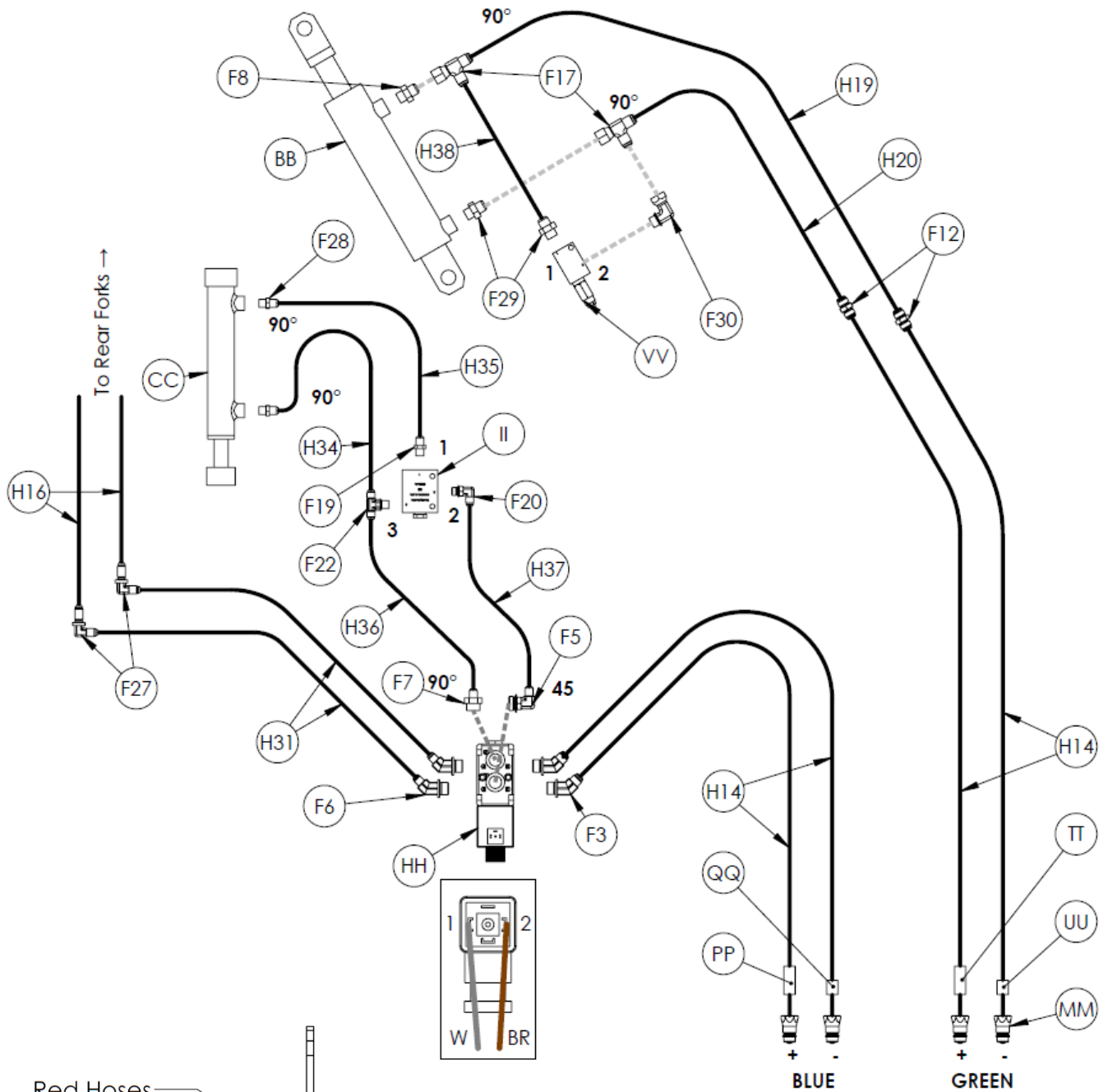

FRONT PANEL – KICKER – 2-REMOTE

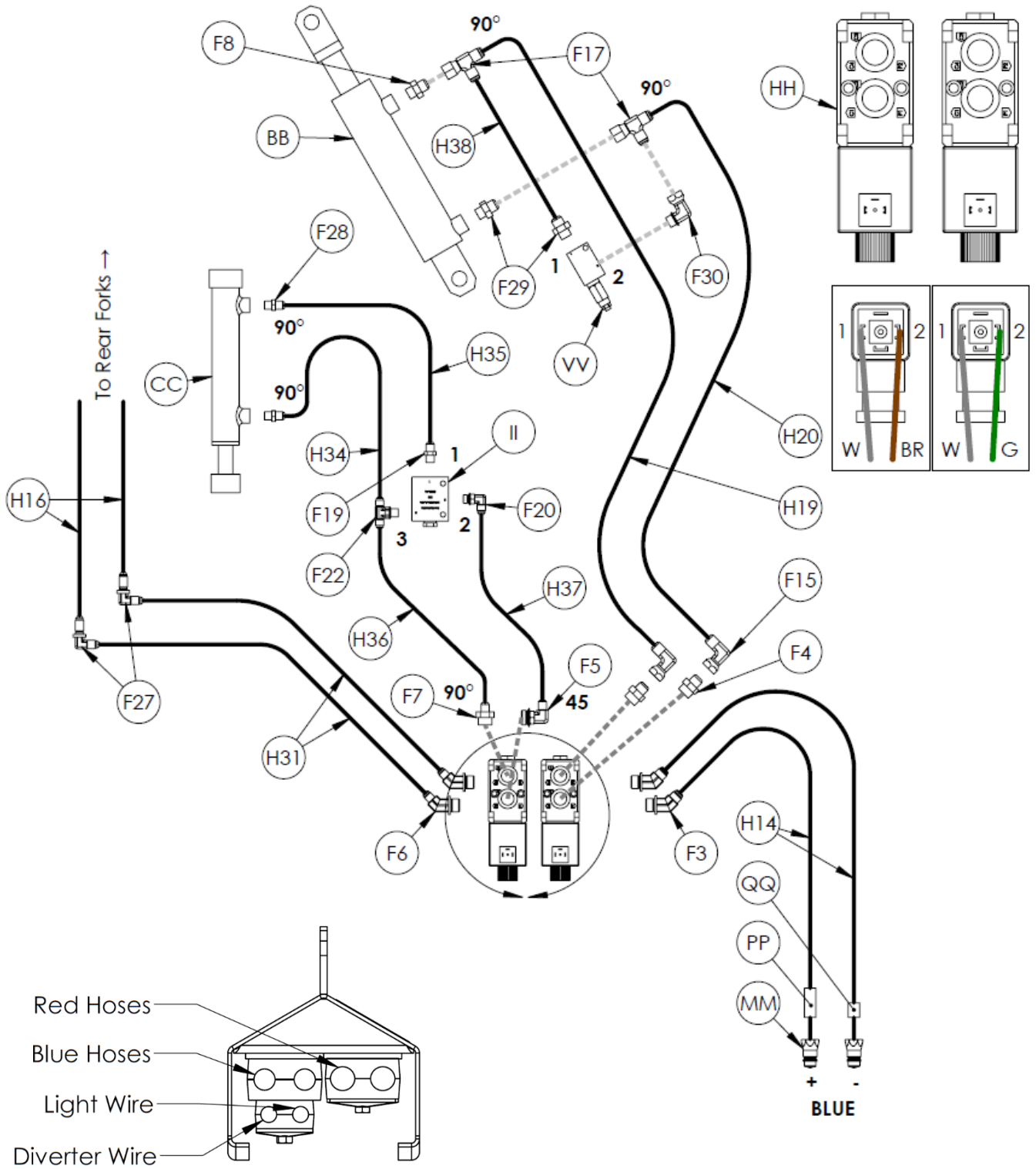

FRONT PANEL – THREE BALE CLAMP & TOTAL RATION – 4-REMOTE

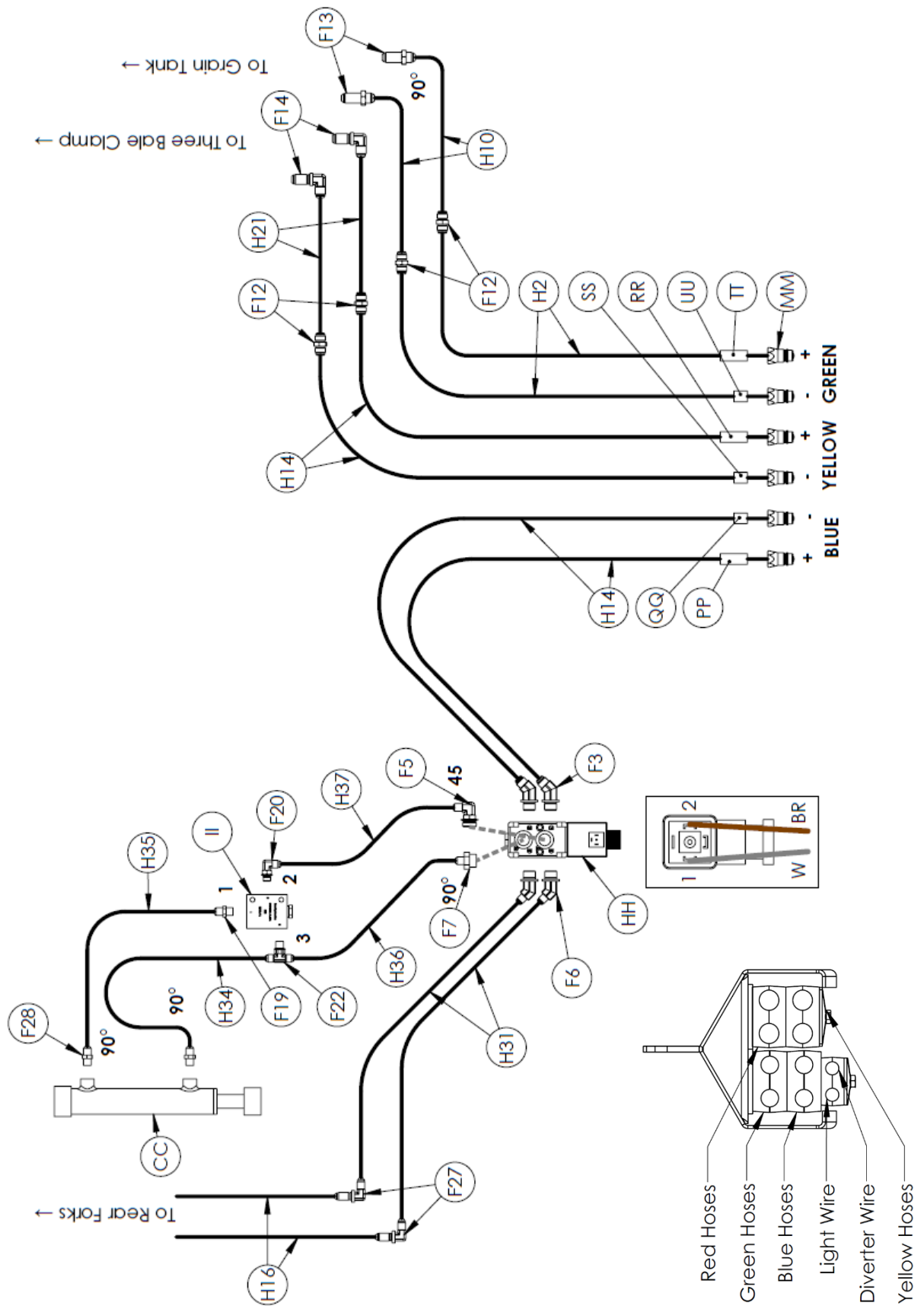

FRONT PANEL – THREE BALE CLAMP & TOTAL RATION – 3-REMOTE

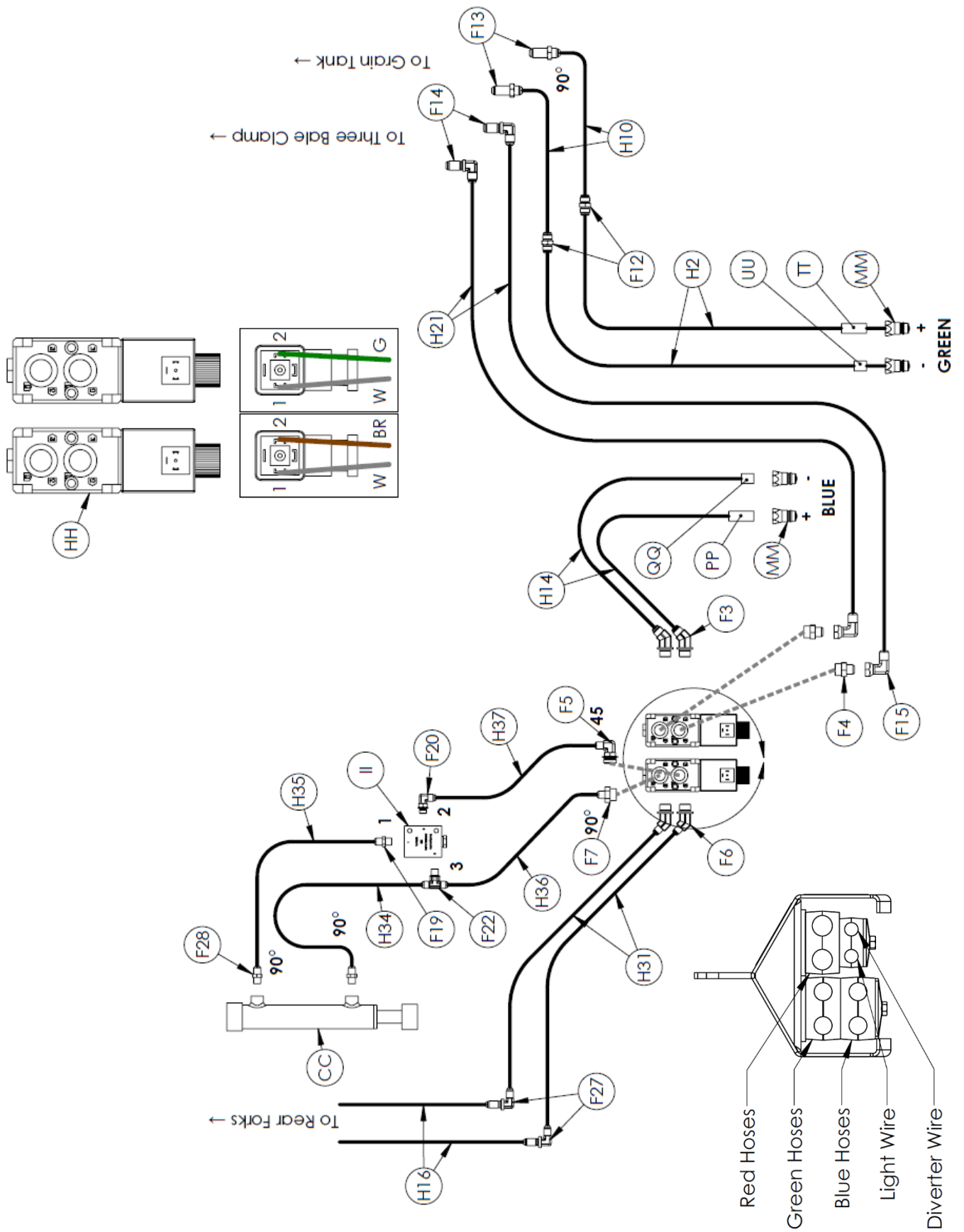

FRONT PANEL – KICKER & THREE BALE CLAMP – 4-REMOTE

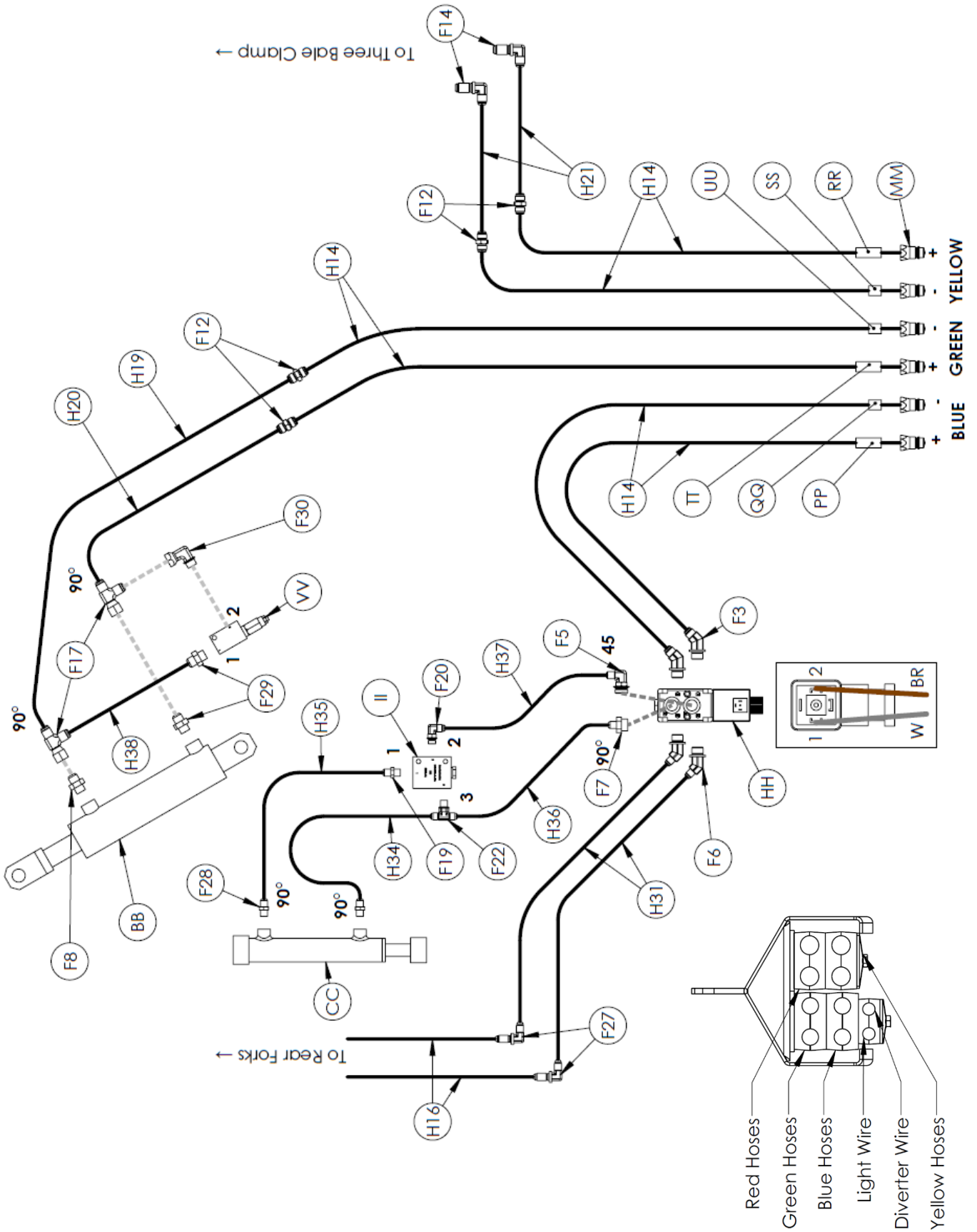

FRONT PANEL – KICKER & THREE BALE CLAMP – 3-REMOTE

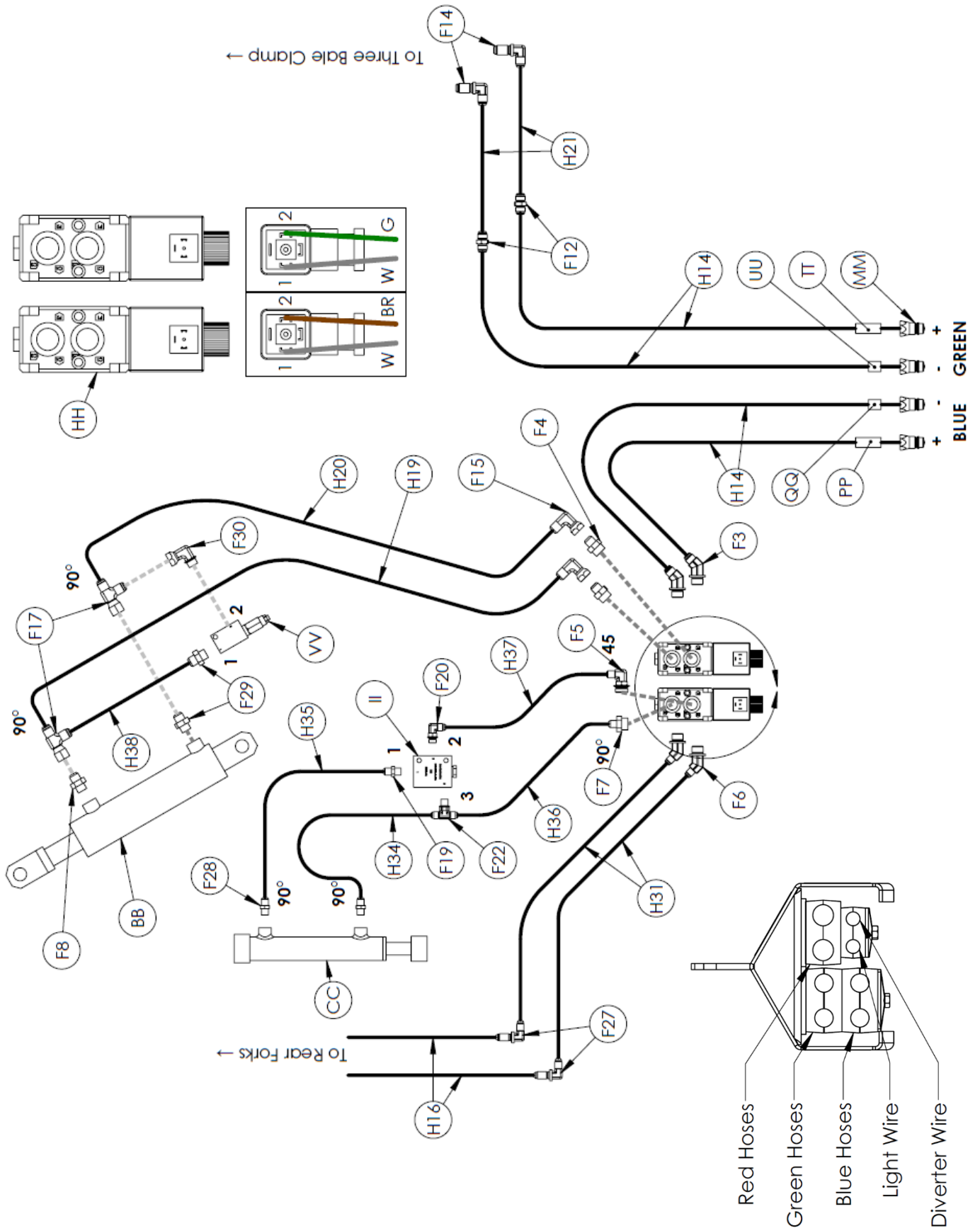

FRONT PANEL – KICKER & TOTAL RATION – 3-REMOTE

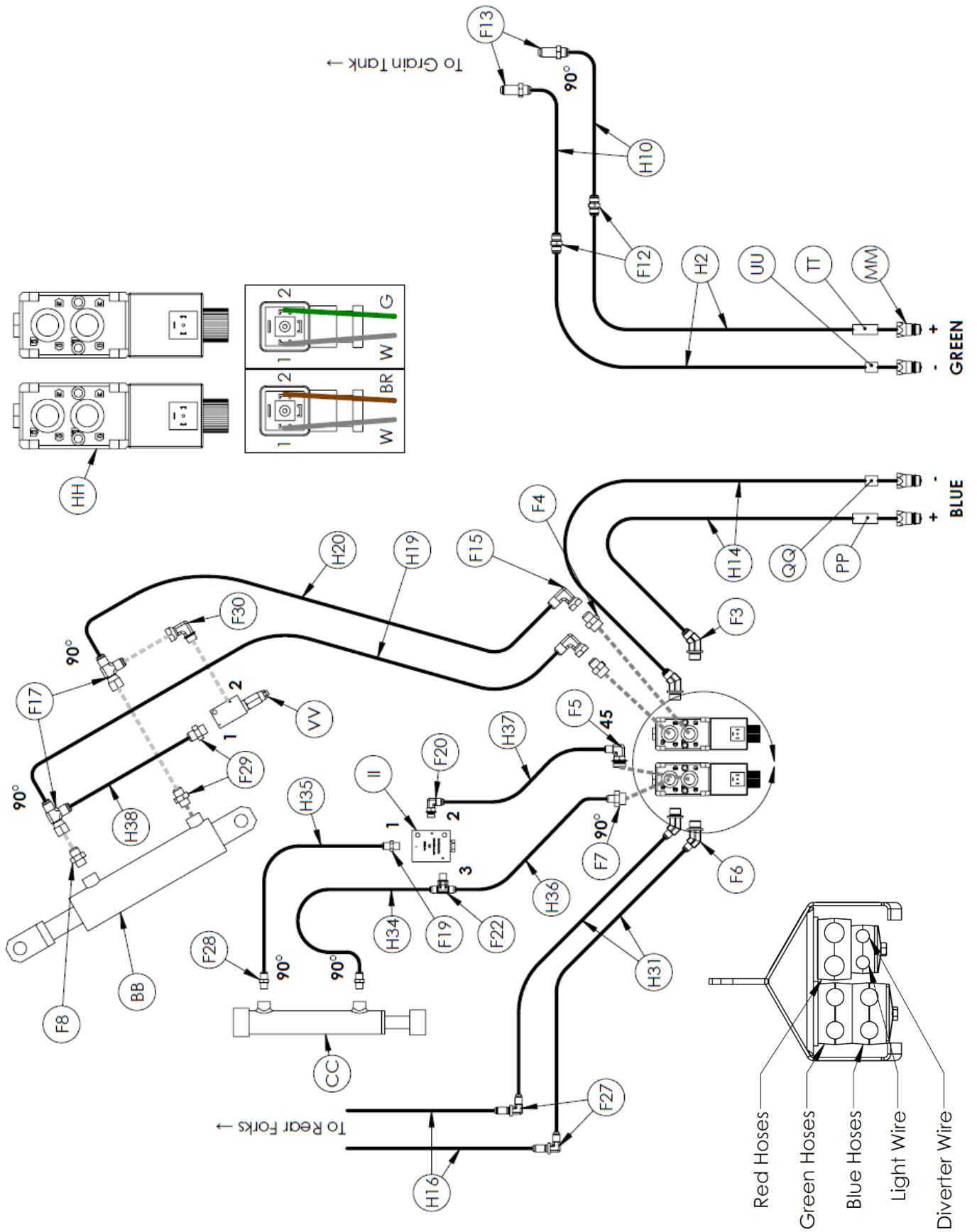

FRONT PANEL – 3 OPTION – 4-REMOTE

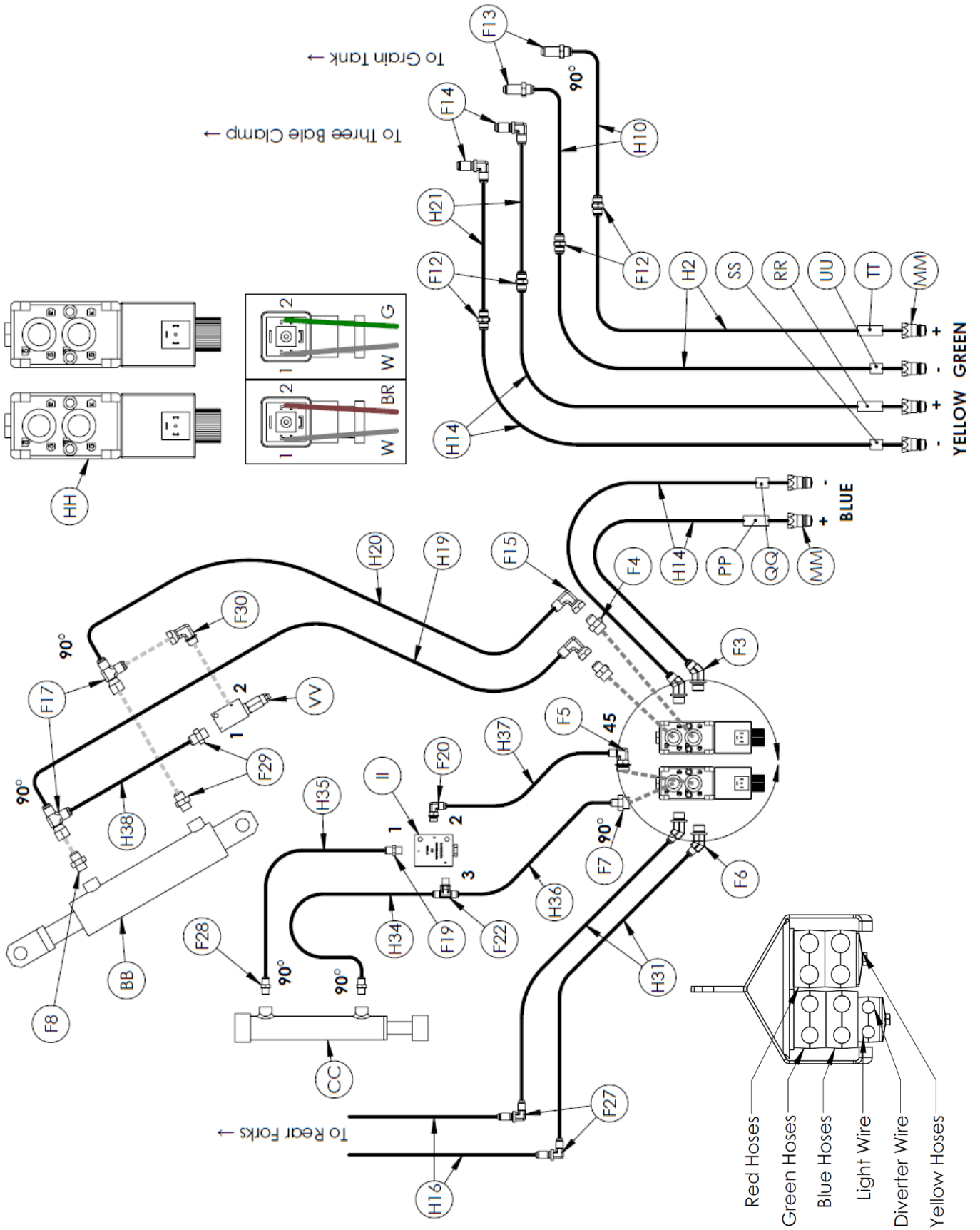

FRONT PANEL – 3 OPTION – 3-REMOTE

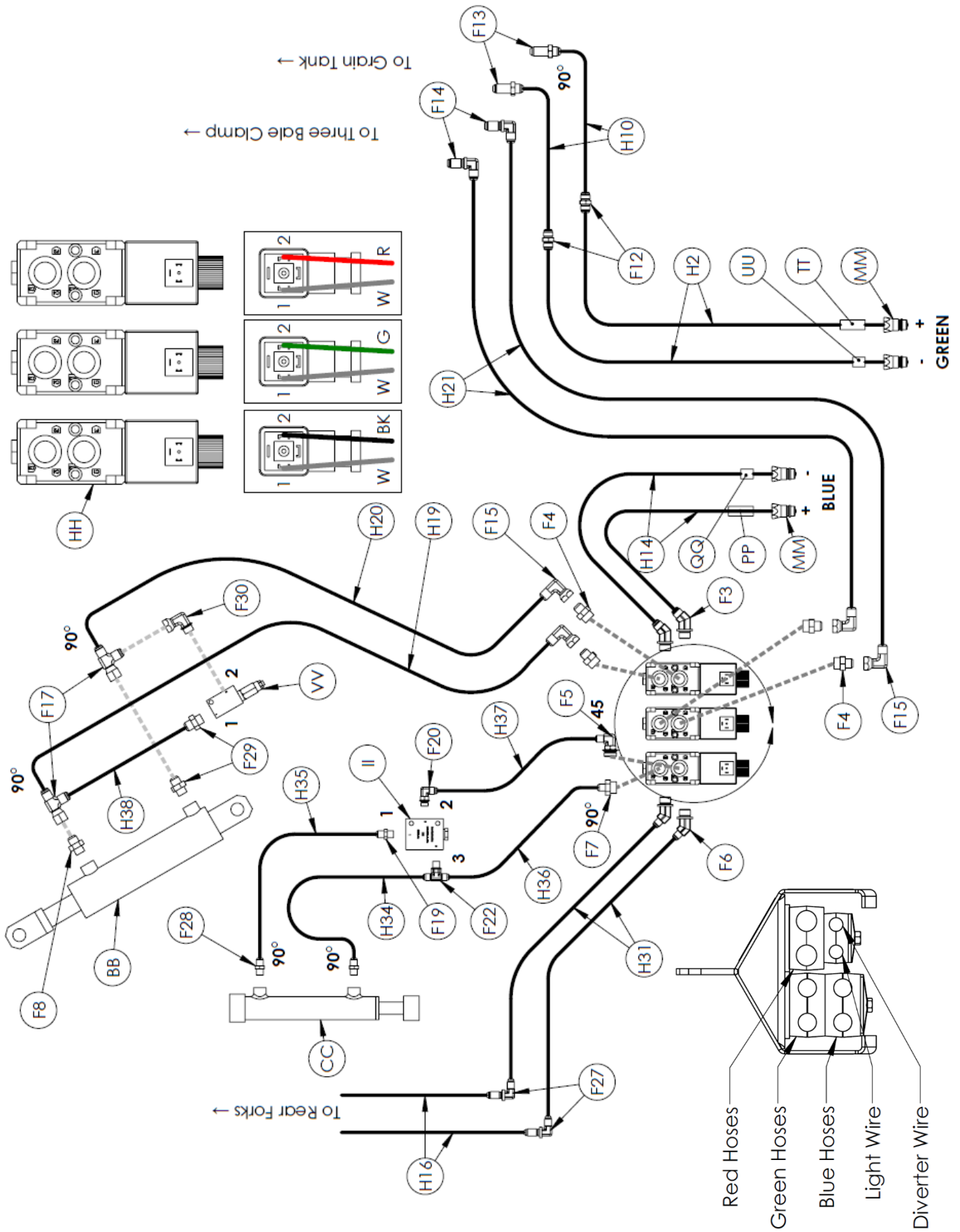

REAR FORK

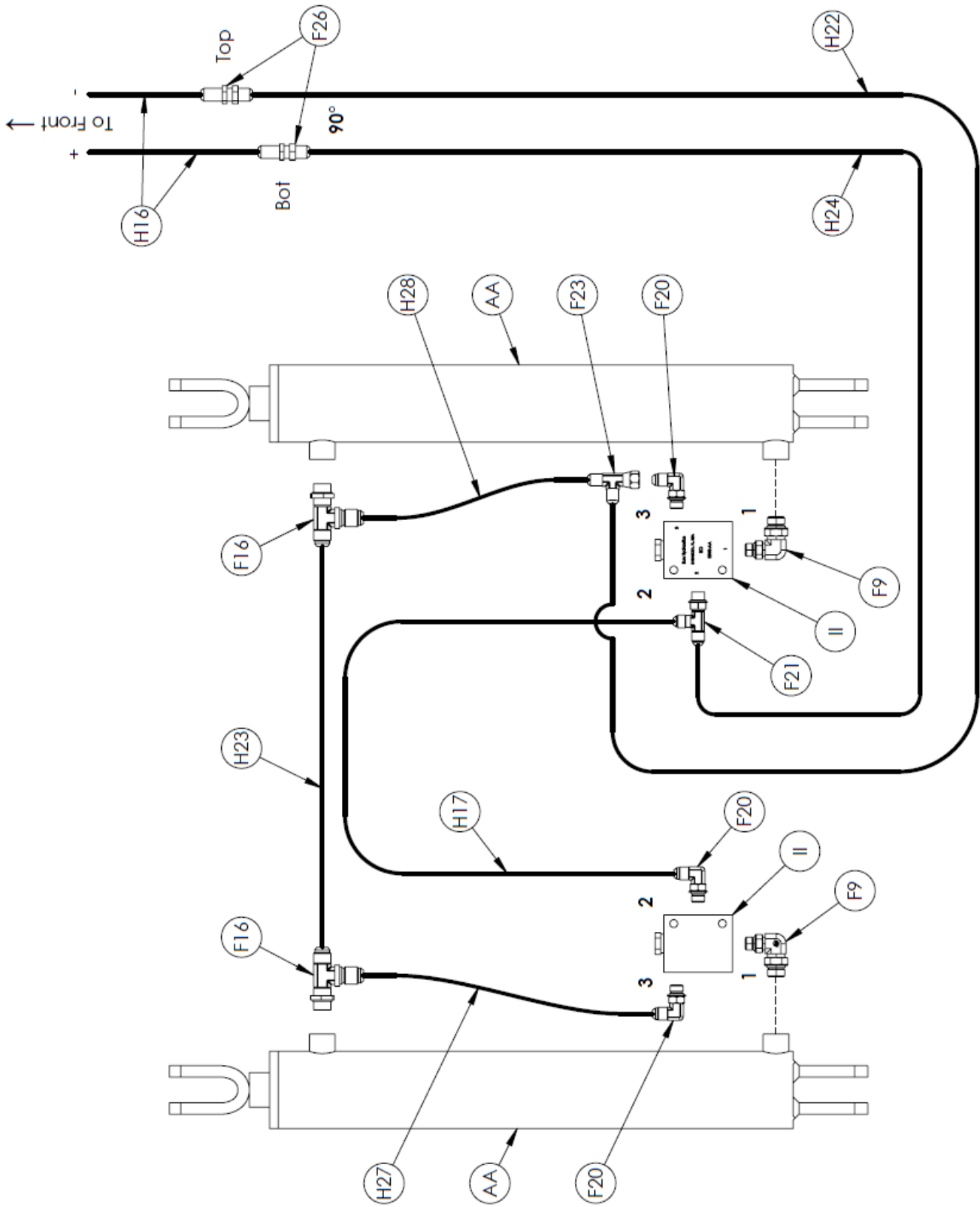

REAR FORK AND THREE BALE KIT

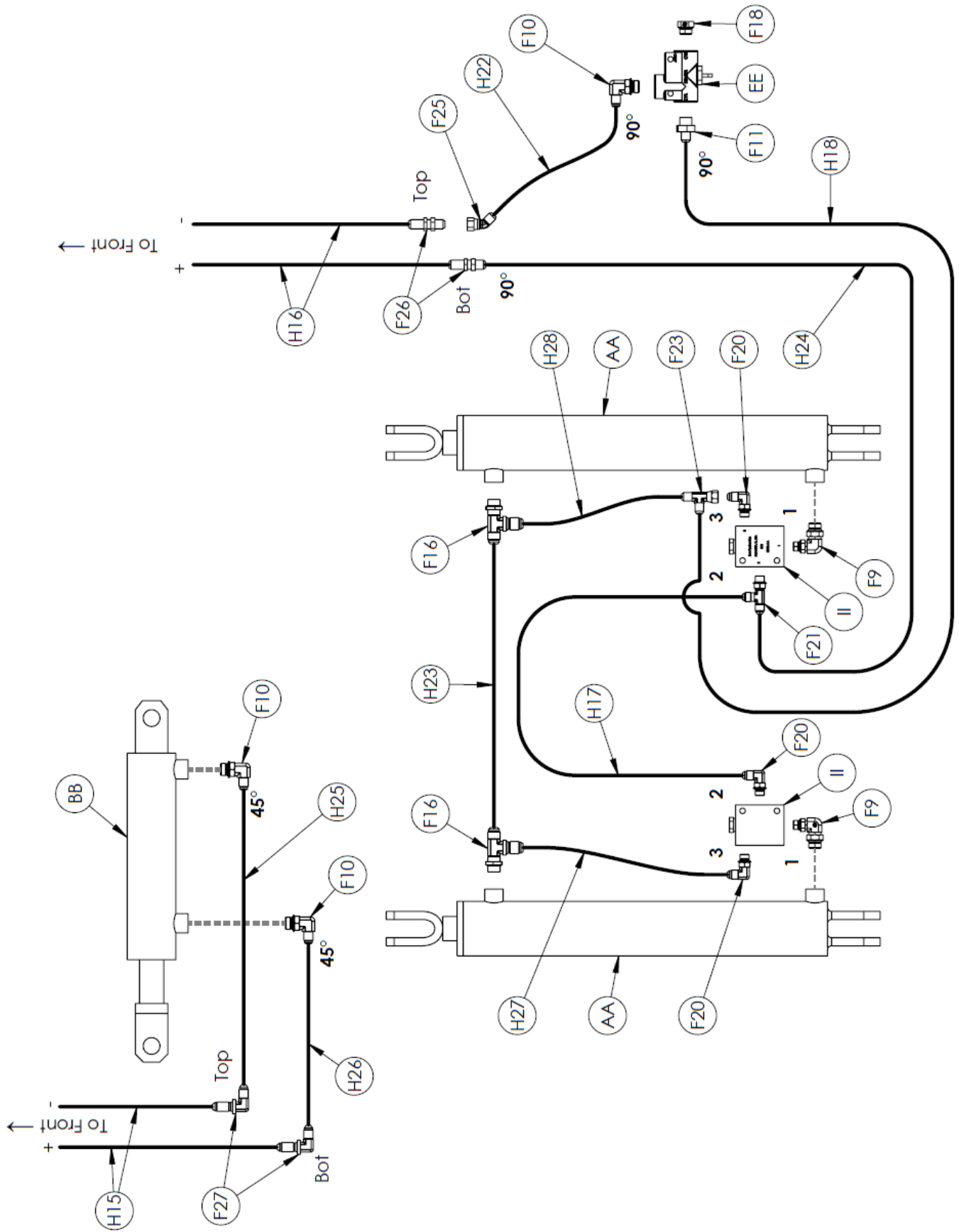

TR GRAIN TANK KIT

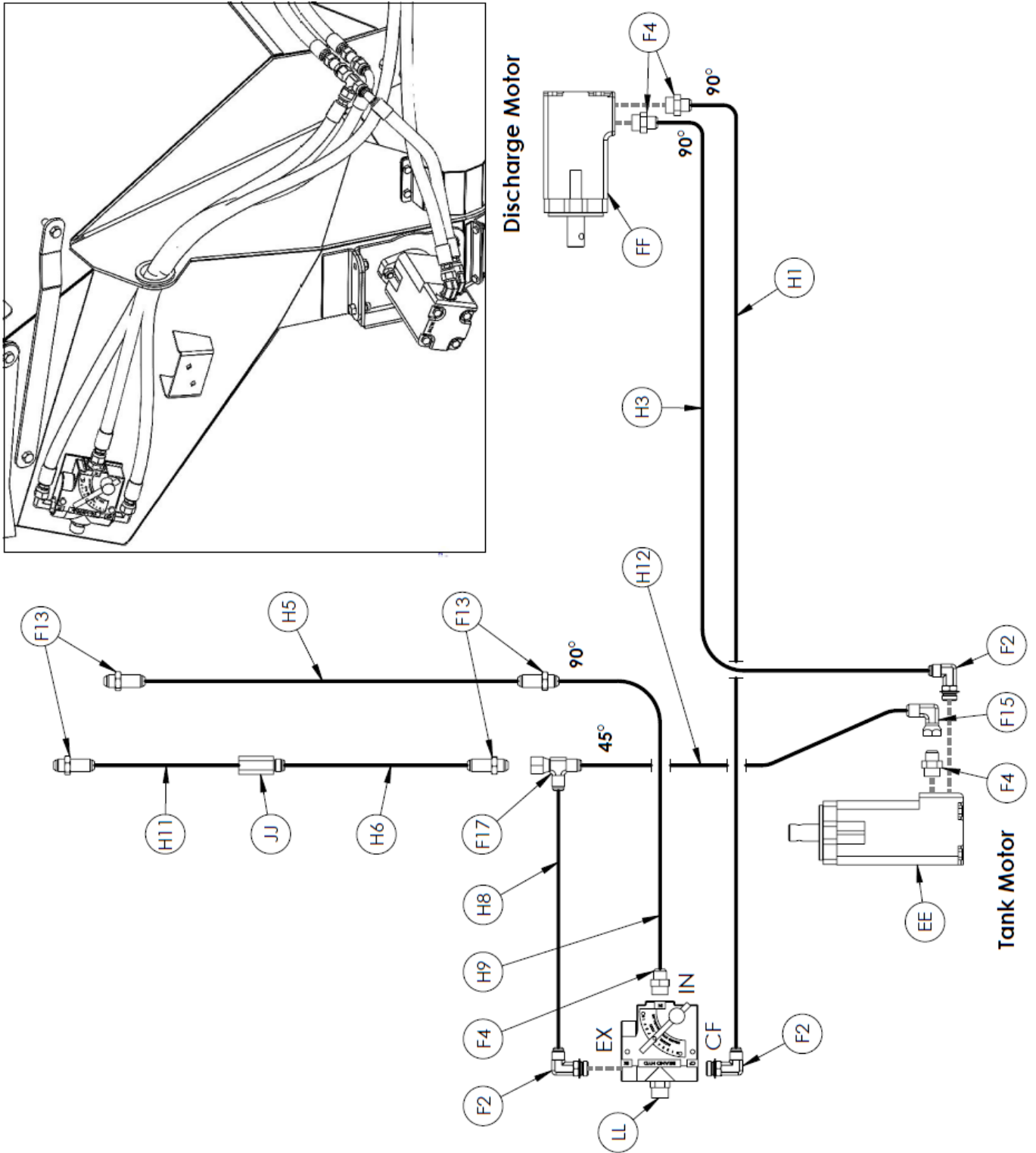

NOTES

A series of horizontal dashed lines for taking notes.