



BRIDGEVIEW MFG. INC.



BALE KING 6300 / 6300TR

Bale Processor

Operator's & Parts Manual

Last Updated: November 2025



Bridgeview Manufacturing Inc.

P.O. Box 4

Gerald, Saskatchewan, Canada

S0A 1B0

Phone: 1-306-745-2711

Fax: 1-306-745-3364

Email: bridgeview@bridgeviewmfg.ca

www.bridgeviewmanufacturing.com

Your Authorized Dealer

Your Serial Number

The Serial Number is located the front tub panel, next to the operator manual box.

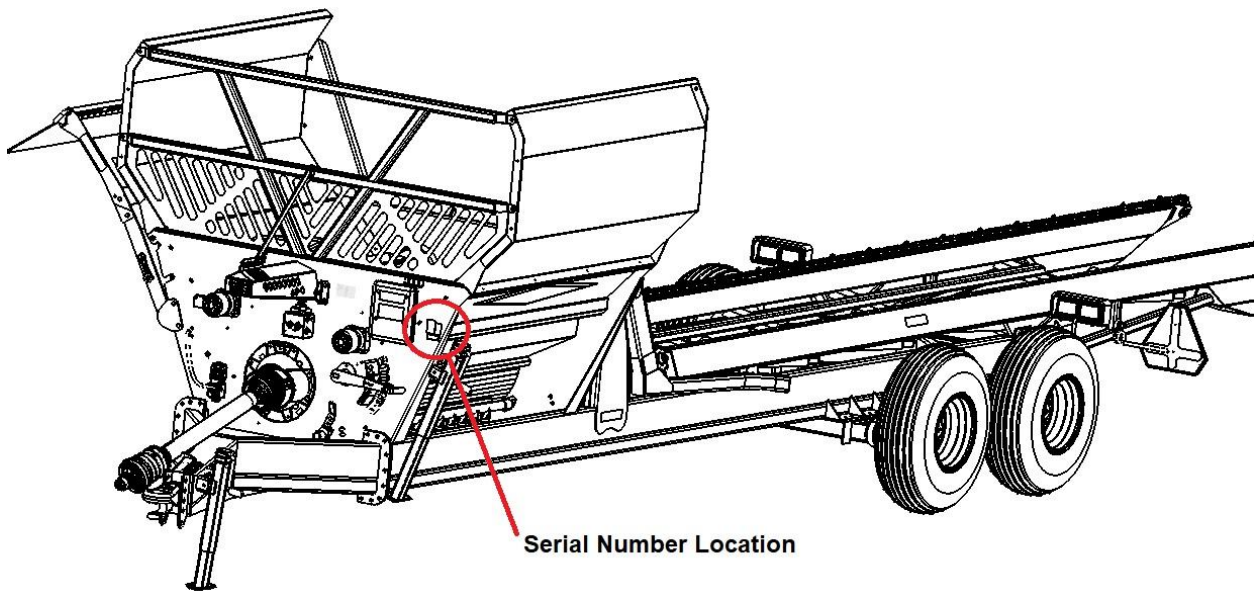

	<p>⚠ WARNING</p> <p>Failure to read and understand operator's manual & all safety signs could result in serious injury. Manual must remain with machine.</p>
---	--

TABLE OF CONTENTS

INTRODUCTION 1
 Safety Precautions..... 1
 Safety Decals 2
 Transportation..... 4
FEATURES & OPERATION..... 6
 Power Take-off 6
 Hydraulics 10
 Hose Holder 12
 Implement Tongue 13
 Torflex Axles 13
 Loading Bales 14
 Loading Fork..... 15
 Setting the Processor..... 16
 Hoop Grate Adjustment 16
 Bale Roller Speed 17
 Rotation Direction..... 17
 Deflector 18
 Optional Fine Chop Kit..... 20
 Optional Total Ration Grain Tank (6300TR) 21
SERVICE AND MAINTENANCE 22
 Greasing Locations 22
 Wheels & Tires 25
 Twine Removal..... 27
 Feeding Chain 28
 Gearbox and Flail Replacement Procedure..... 29
 Trouble-shooting Guide 30
 Features and Specifications..... 31
PARTS MANUAL..... 33

INTRODUCTION

Thank you for purchasing a **Bale King** bale processor. With the proper operation and service as outlined in this manual, the Bale King will provide you with years of trouble-free operation.

This is a complete safety, operation and parts manual for the Bale King 6300. The manual covers in detail how to safely and effectively use your new processor. The procedures outlined in this manual should be followed to ensure safe operation and longevity of your machine. The parts manual covers all parts you may need to order in case of accident or breakdown. Please read completely through this manual before beginning operation of your new machine.

Safety Precautions

The following safety precautions MUST be followed to ensure safe operation of the Bale King bale processor.

- **ALWAYS** turn **OFF** the tractor when leaving the operating platform.
- **DO NOT** stand in front of the discharge chute while the machine is running.
- **DO NOT** walk or move under the bale forks when they are in the upward position, unless the cylinder safety lock is in place.
- **DO NOT** enter the machine while in operation.
- **DO NOT** clean machine while in operation.
- **DO NOT** stick any device into the machine to clear debris while the machine is in operation.
- **ALWAYS** turn off the machine when cleaning the machine, removing twine, or hooking / unhooking the machine
- **ALWAYS** use safety chain when towing the machine on a highway.
- **DO NOT** operate if any part of the **PTO safety shielding** is missing or is not secured.

Safety Decals

Power Take-off:

The operator must obey all safety labels and must maintain the proper shielding. A high percentage of drive-line injuries occur when safety shielding is missing or not functioning properly.

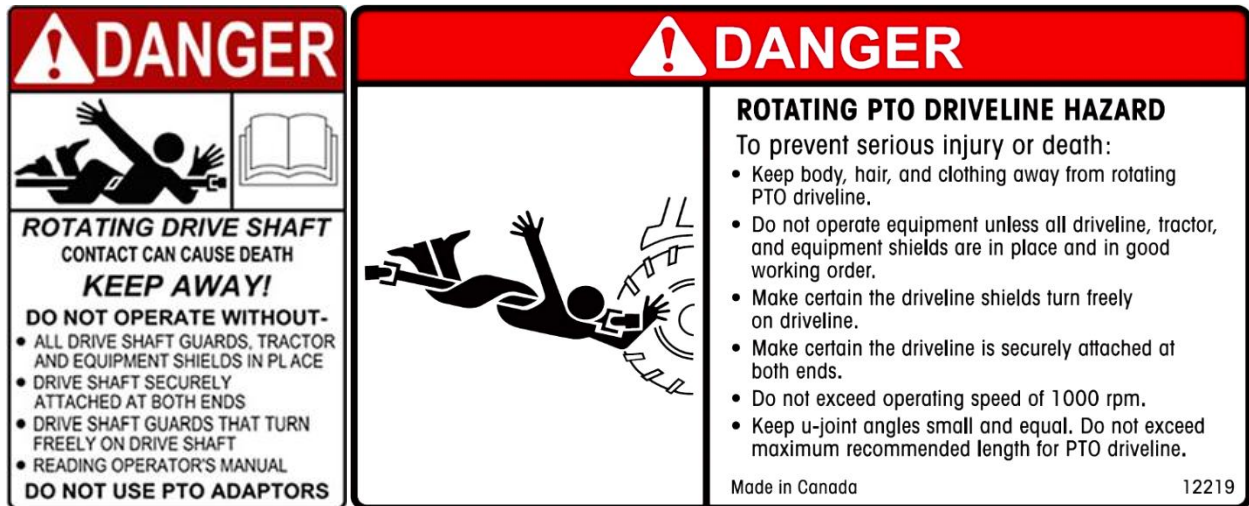

DANGER: *Contact with a rotating drive-line can cause serious injury or death.*

Discharge:



DANGER: *Do not stand on the discharge side of the machine while it is in operation.*

Rear Fork Lift Area:

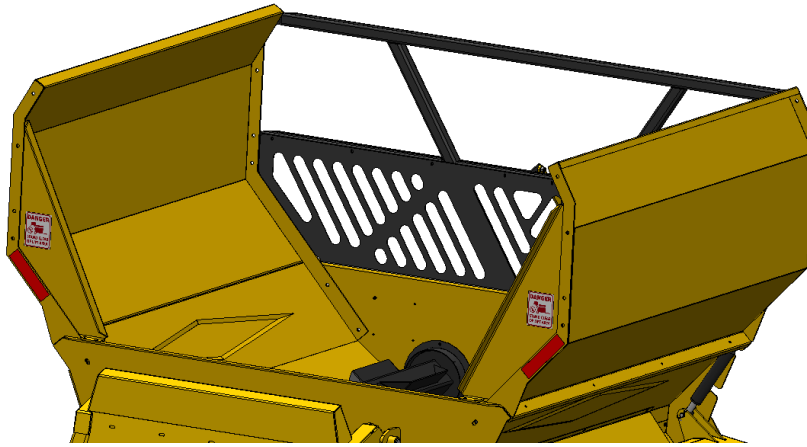

DANGER: *Stand clear of lift area. Do not stand under the forks if tractor is running or if bale is resting on forks. Automatic hydraulic safety locks are installed.*

Deflector Safety Lock:

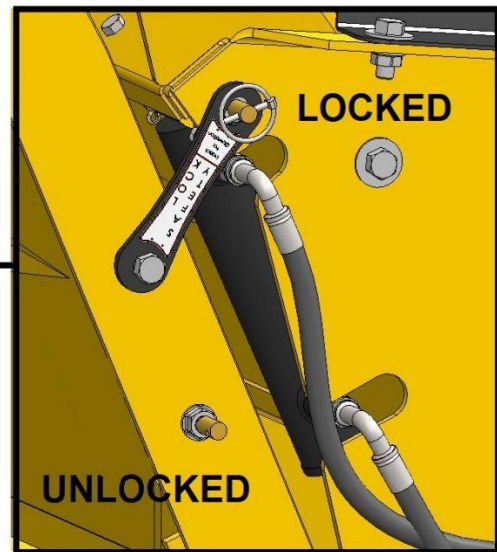

Unlock for operation, Lock for transport and storage

Transportation

The Bale King 6300 can be safely towed on public roads, provided the following precautions are met:

Weights and Dimensions

- The towing vehicle must be suitable for the weight being towed.
- Check with local authorities regarding transport on public roads. Follow all applicable laws and regulations.
- Be aware of your size and weight. Adjust your driving accordingly

	Empty		Loaded	
	6300	6300TR ¹	6300	6300TR ¹
Total Weight	9060 lb	9700 lb	19200 lb	21400 lb
Hitch Weight	3100 lb	3400 lb	3600 lb	3800 lb
Length	39'-10"			
Width ²	9'-10"	10'-8"	9'-10"	10'-8"
Height	8'-9"		10'-0"	

NOTE 1. The 6300TR features the optional Total Ration grain tank

NOTE 2. Width can be reduced to 8'-6" by folding the deflector

Speed

Tow Vehicle Weight	Empty Processor	Loaded Processor
15000 lb and Under	32 km/h (20 mph)	Not recommended
Over 15000 lb	40 km/h (25 mph)	32 km/h (20 mph)

- The processor features implement tires and hubs and is not suitable for high speed travel
- The processor does not have brakes.
- Slow down for rough conditions, turns, and steep declines.
- If towing long distances, ensure the machine is empty (no bales in tub or on fork)
- If hauling one bale only, place it in the tub instead of on the fork.
- If hauling up to six bales, speed should be further reduced. Make sure that one bale is loaded into the tub, and the remaining bales are shuttled forward to reduce the risk of falling off the bale. Note that there will still be a significant amount of weight behind the axle, causing more "tail whip". This also raises the center of weight of the machine.
- Failure to heed these warning may result in loss of control or death.

Safety Chain, Jack, PTO, and Hydraulics

- ALWAYS ensure that the safety chain is properly installed. There should be enough slack to allow for turning, but not so much that the chain drags on the ground.
- Ensure that the jack is installed in its storage position on the front tub wall.
- Ensure that the PTO and hydraulic hoses are properly secured
- PTO and hydraulic lines must be connected to the tractor during transport.
- If towing with a pickup, the outer PTO shaft must be removed, and the inner shaft and hydraulic hoses properly secured. The exposed end of the inner PTO shaft should be covered to protect the splines from dust/rocks, etc.

Wheels and Tires

- Check tire pressure and wheel torque. Wheels must be retorqued after 1 hr if being transported for the first time.

Tire Pressure	35 psi	Wheel Torque	125 ft-lb
----------------------	--------	---------------------	-----------

- If transporting long distances, periodically check the tires and hubs for high temperatures. If heating up, you must slow down.

Lights and Marking

- Tow vehicle must have a 7-pin round trailer plug
- Plug in lights and check for proper function and visibility (flashing amber lights, red tail lights and brake lights).
- If towing with a pickup, an adapter will be required to plug into the trailer plug. When braking, both amber lights should activate. Tail lights should always be on.
- Ensure that the supplied SMV (Slow Moving Vehicle) sign is clearly visible from the rear
- Ensure that the reflective markers are cleaned, and visible from all sides

Safety Locks

- If possible, the deflector should be in the folded position.
- Ensure that the deflector safety lock is installed



FEATURES & OPERATION

Power Take-off

The Bale King bale processor has a PTO shaft which is splined on both ends. The implement end uses a 1-3/4"-20 spline with wedge lock bolts. Install onto the gearbox and tighten the wedge bolts. The bolts should be torqued to **160 ft-lb** and re-torqued after 8 hrs of use.

The tractor end comes standard with a 1-3/8"-21 spline quick detach constant velocity joint. An optional 1-3/4"-20 spline yoke is available through your Bale King dealer.

<p>MAXIMUM 150 HORSEPOWER TRACTOR PTO</p>
--

NOTE: *Spread yokes and twisted drive shafts are signs of OVERLOAD, not a manufacturer's defect and therefore not covered by warranty.*

- **DO NOT** operate the machine using a spline adaptor. Use of adaptors will **void warranty** due to damage caused to the tractor PTO, PTO driveshaft, or implement.
- **DO NOT** operate at 540 rpm, or use any kind of adaptor to connect to a 540 rpm spline.
- **ALWAYS** ensure that the PTO shaft is attached securely to the tractor. When the processor is not hooked to the tractor, store the shaft on the PTO holder.
- **DO NOT** transport the processor without securing the PTO shaft. See next page for securing instruction.
- **ALWAYS** ensure that the drawbar is adjusted to **16"** from the end of the tractor PTO shaft to the center of the hole in the drawbar.

Operation

To engage the rotor for processing a bale, be sure the PTO shaft is properly connected to the tractor. Engage the PTO at idle. After the PTO is fully engaged, increase PTO speed until it reaches 1000 RPM.

The processor must not run at any speed less than 1000 PTO RPM as it may result in the flails springing back against the rotor after they come in contact with the bale. This "**backslap**" may cause flails to fatigue and excessive vibration which may cause the bearings to fail. Bales may be dumped into the tub while the rotor is stopped or while it is running.

Shear Bolt

All new Bale King processors are equipped with a **shear bolt** clutch located at the implement end of the PTO shaft. The correct size shear bolt is **3/8 x 2" Fine Thread Grade 5 with Stover Lock Nut**. Any other size or grade will **damage** the shear assembly. Spare shear bolts are shipped with each new machine and are stored along the front top lip of the tub.

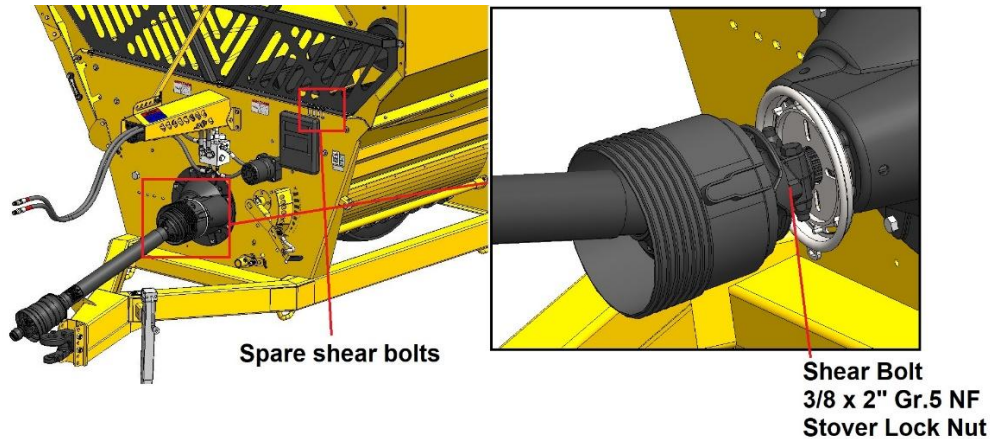

If your shear bolt is shearing excessively you may be over-loading the machine. If this occurs raise the grate assembly to make the machine less aggressive, or roll the bale more slowly by slowing down the rollers. **Always ensure that your machine is running at 1000 PTO RPM.**

NOTE: Please consult your local dealer to help pinpoint any problems.

PTO Holder

A PTO shaft holder is standard with your new Bale King, for safe storage of the PTO shaft when the processor is not in use.

When unhooking the PTO shaft from the tractor, retract and then swing the PTO to the right to rest the PTO on the holder.

DO NOT transport the machine with the PTO in the holder. Slide the outer PTO shaft out and secure elsewhere. When transporting, fasten the inner PTO shaft to the machine and cover the open splined end.

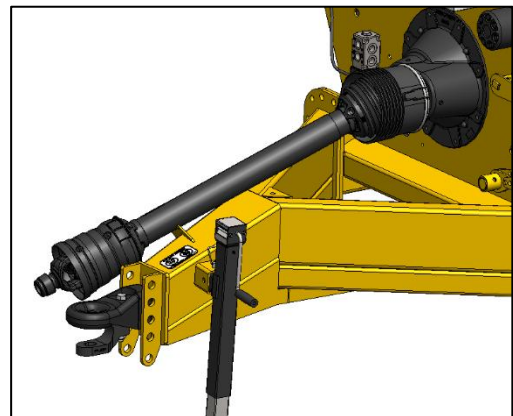

PTO Use and Maintenance

Shut **OFF** the tractor engine and remove the key before doing any maintenance on the machine. Use **ONLY** genuine **Weasler** parts when replacing any worn or damaged PTO components.

Length:

Confirm the minimum and maximum working lengths of the drive-line. The telescoping tubes must overlap at least 1/3 of their length when in use. The PTO is designed to be used with a drawbar length of 16" from the end of the PTO shaft. Adjust your tractor accordingly.

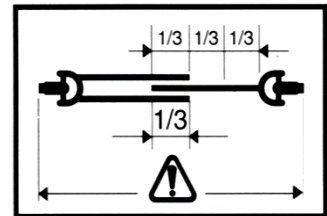

Shielding:

Be sure that the shielding is not damaged and rotates freely on the drive shaft.

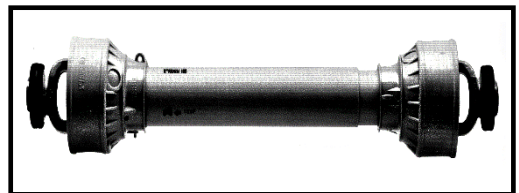

Working Angles:

Constant Velocity joints can operate up to 80 degrees for short periods of time. Do not operate for long periods on sharp angles.

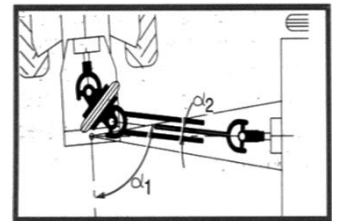

Attachment:

Be sure the drive-line is properly attached and all bolts and screws are tight on the implement input shaft and on the tractor PTO shaft.

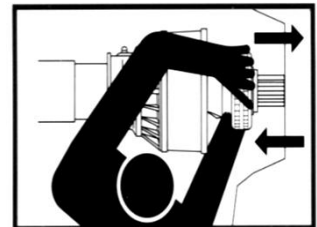

Storage:

When not in use, cover or protect the drive shaft from the weather.

When removed from the machine store both halves together to prevent damage. Check all components for proper function and lubrication before use.

**BEFORE ATTEMPTING ANY REPAIR PROCEDURES,
ALWAYS USE APPROPRIATE EQUIPMENT SUCH AS
SAFETY GLASSES, SAFETY SHOES, AND GLOVES**

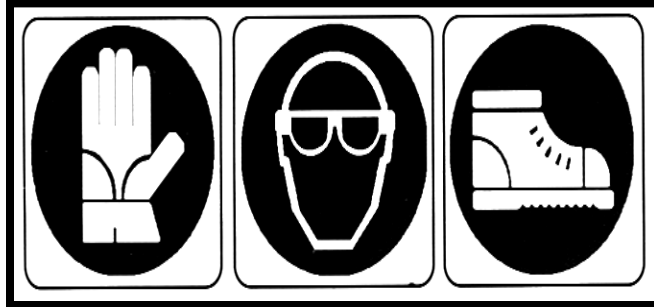

Shield Removal:

- To remove the shield, pop out the red snap, then rotate the guard on the bearing to line up the three tabs with the openings and pull it off away from the knuckle joint.
- Remove the nylon bearing from the shaft by spreading it open.



Shield Assembly:

- Be sure to lubricate the groove in the inner yokes where the shield bearing rides. Reinstall shields in the reverse order that they were removed.



Lubrication:

- Be sure to follow the lubrication timeline as outlined on page 22
- Use low temperature grease if operating in cold temperatures. This will allow the PTO splines to slide much easier in these conditions.

Hydraulics

WARNING: *Pressurized hydraulic fluid can cause serious injury.*

- When working with hydraulic equipment, eye and hand protection should be worn.
- Do not test for leaks with bare hands.
- Relieve any pressure before removing a hose or fitting.
- Never work under components raised by hydraulic equipment unless supported externally.
- Always set the tractor's hydraulic flow at a lower rate and adjust it upward until the desired speed is reached. Excessive oil flow may damage the flow divider cartridge.



There are three sets of hydraulic hoses to connect to the tractor. Each hose has a coloured marker to identify its function. They should be connected at best convenience for the tractor's controls. Note that the hoses are paired by colour and the following tables show the operation when pushing oil into the hose with the longer marker.

Control Box	Hose Function		
	“AUXILIARY”	“FORK”	“DEFLECTOR”
Long Blue	Lift bed	Lifts rear fork	Lift deflector
Long Yellow	Conveyor chain towards tub		
Long Red	Turns rollers clockwise		

The Bale King 6300 processor has a diverter kit which allows it to operate using only 3 hydraulic remotes. The fork, deflector, and bed tilt functions are then controlled by a cab-mounted switch box. This box must be wired up to the tractor's electrical system. You may use the provided plug to plug into the accessory outlet. If this is not available, the plug can be disassembled, and wired as necessary.

A 4-pin plug is used to power the diverter valve on the processor. If no power is supplied, the hydraulics will still control the rear forks, but the deflector will not be functional. If the switch in the tractor is activated, the deflector can be controlled.

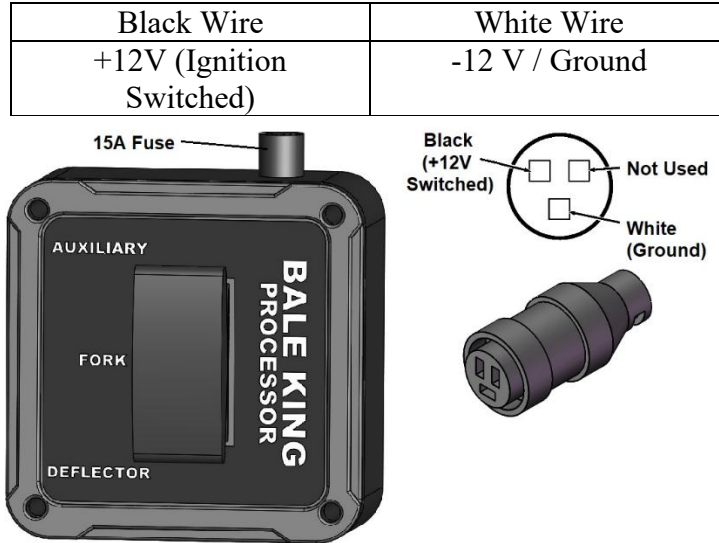

An optional grain tank kit is available to allow the Bale King 6300 to carry 40 bushels of grain on the side of the machine (see page 21). If this kit is installed, additional motors are added to the hydraulic functions. This changes the hydraulic setup as shown below. A different control box is also required, which has an additional push button switch to control the grain tank.

6300TR – 3 Remote				
Control Box	“AUXILIARY”	“FORK”	“DEFLECTOR”	“GRAIN TANK”
Long Blue	Lift bed	Lifts rear fork	Lift deflector	Discharge grain
Long Yellow	Conveyor chain towards tub			
Long Red	Turns rollers clockwise			



* 6300TR Control Box with additional push button switch

Hose Holder

The hydraulic hoses may need to be adjusted to avoid damage from rubbing on the PTO shaft. This can be done by lifting or lowering the hose holder. Loosen the pin handle, then lift the end of the hose holder to drop the pin into the slot. Then adjust the height as desired and catch the pin into the desired notch. Finally, retighten the pin handle to prevent it from switching positions if the machine bounces.

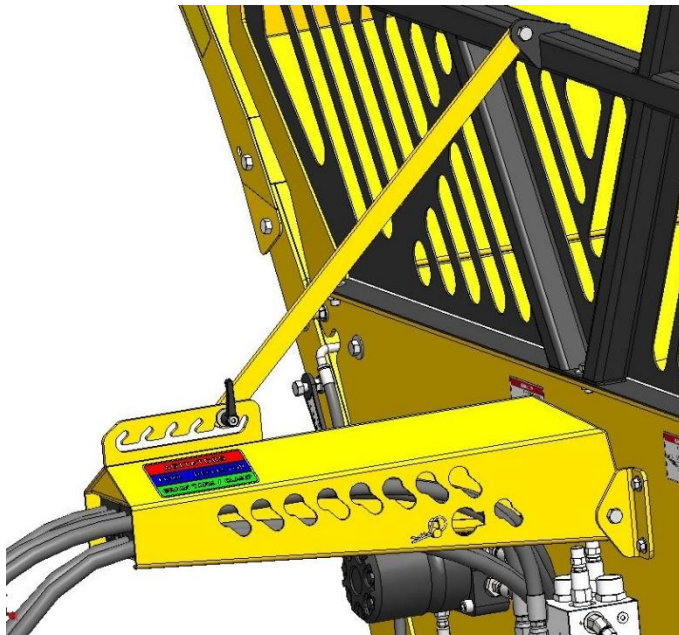

Loosen handle
Lift end of holder
Slide pin in slot
Choose setting
Tighten handle

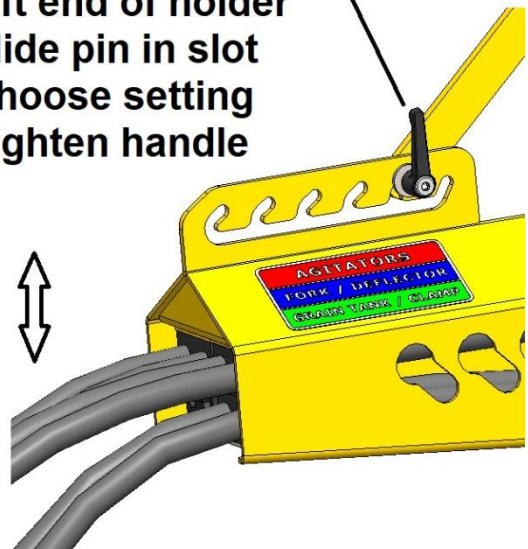

Implement Tongue

The adjustable hitch on the Bale King features a cast single tongue with optional clevis insert (**BMI #25540**). This allows for use with tractors equipped with a hammer strap or with a single drawbar. It also allows the machine to move independently over rough terrain without bending the draw pin.

- Make sure that the drawbar is set to **16 inches** behind the PTO shaft for proper PTO length.
- Adjust the hitch height to match the tractor drawbar height as close as possible. When properly adjusted, the frame rails should run level.
- **DO NOT** install the clevis insert if using a tractor with a hammer strap as this will bend the hitch pin.
- **ALWAYS** connect the safety chain during road transport

Torflex Axles

The Bale King 6300 features a pair of Torflex axles, which provide suspension and allows a smooth ride over rough terrain.

There are 3 available mounting locations available. From factory, axles are set up in the middle position. Axles can be moved forward to slightly reduce hitch weight on tractor, or rearward to slightly improve handling (by reducing tail swing).

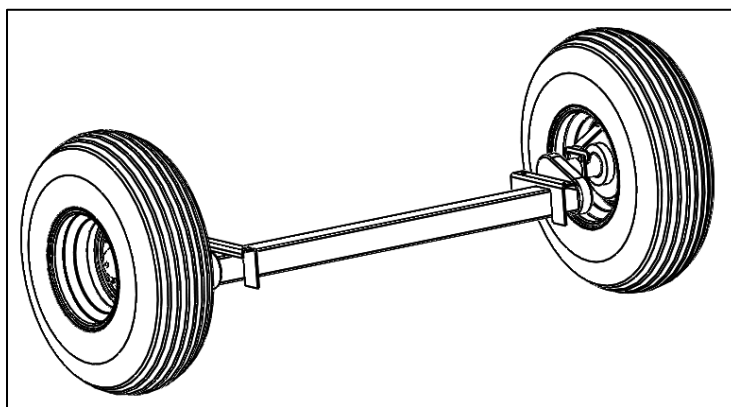

Loading Bales

When loading bales into your Bale King bale processor, the following procedure should be followed:

- Position the processor so that the back of the deck is aligned with the center of the row of bales you wish to load. Align the processor so that you can back straight into the row.
- Raise the deck until the skid shoes gently touch the ground.
- Back slowly under the row of bales and rotate the conveyor chain to draw the bales up the deck, matching tractor speed to the chain speed. Let the chain run until the first bale reaches end of the deck.



- Stop rotating the chain and load the first bale into the tub with the fork. Make sure to fully lower the fork once the bale is in the tub.



- Rotate the conveyor chain to draw bales up onto the deck while backing slowly under the row of bales to pick up one more bale.

- Lower the deck once the final bale is loaded. Allow the tractor to roll forward as you lower the deck to avoid nudging the remaining stack of bales.



TIP: Once the bale is on the deck, lower the deck slightly to minimize twine build-up on the rear sprocket.

Loading Fork

The loading fork on the Bale King 6300 can handle up to 6.5ft bales. The loading fork is designed to load bales into the tub while the deck is inclined or flat. The fork design allows an operator to load all six bales without repositioning the bed tilt.

- Finish processing the bale that is currently in the tub. If dropping a new bale onto an unfinished one, the material may pile up and prevent turning of the bales.
- Use the chain to make sure that the bales are pulled tight up to the fork
- Lift the fork to tip the bale into the tub. You may slow it down at the end to allow the bale to fall more gently into the tub.
- It is common practice to leave the rotor running while the new bales are being loaded. However, the rollers should not be turning.
- Fully lower the fork.



Never stand under the forks. When greasing or servicing around the rear end, the forks should be down. Never attempt to loosen or replace hydraulic hoses while the forks are up.

Setting the Processor

Processing speed must be balanced with overall aggression and vibration levels. Excessive continuous vibration may affect the service life of the processor. Processing times of 1-2 minutes are considered normal in dry bale conditions. Extended times are expected in tougher conditions such as high moisture feed, frozen, or misshapen bales. The processor may need to be adjusted for each type of bale for optimal performance. ***Processing a bale too rapidly may cause excessive vibration and driveline damage.***

There are 3 main components to setting the processor:

1. **Hoop grate height:** Adjusts how far the flails protrude above the grate
2. **Bale roller speed:** Adjusts the feed rate to the rotor
3. **Bale rotation direction:** Controls the feed direction over the rotor

Hoop Grate Adjustment

There are eight adjustment settings for the hoop grate on the bale processor. These settings vary the aggression and length of cut. To adjust, pull the spring handle outward, then swing the handle “UP” for a more aggressive cut, or “DOWN” for less aggression. Then release the spring handle to engage the pin in the desired hole.

When there is a bale in the tub, the bale’s weight will be placed on the hoop grates, making adjustment more difficult. Adjust the machine when it is empty when possible.

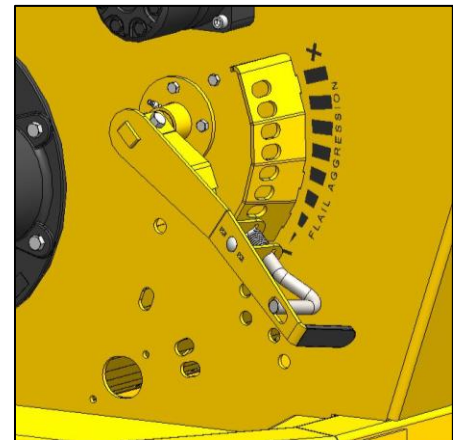

- **Position #1 (Bottom):** Highest grate setting for finest cut and slowest rate of feed. Used for tough processing feeds such as silage bales, or other wet materials.
- **Position #2-6:** Normal operating range. Machine gets more aggressive as handle moves “up”.
- **Position #7-8 (Top):** Lowest grate positions, most aggressive, fastest rate of feed.

The Bale King should be adjusted according to bale conditions to achieve a rate of feed of approximately **1 to 2 minutes**. Light, brittle material such as wheat straw may allow faster processing while tough stringy material such as silage, slough hay, green feed, or flax will require slower processing. Hoop grate adjustment should be checked periodically.

NOTE: *Upper grate position should be approximately 0" flail protrusion. Lower grate position should allow 3" flail protrusion.*

Bale Roller Speed

The Bale King is equipped with a flow divider/combiner and two hydraulic motors for turning the bale. Proper roller speed is critical to smooth processing. Roller speed is adjusted via your tractor's flow control. Set a one-minute timer and count revolutions of a roller paddle. 40 RPM is a typical starting point. Speeds of 30 to 45 RPM are considered normal depending on bale conditions.

If vibration is excessive, slow the rollers and raise the hoops as necessary to adjust. Excessive roller speed will overload the processor and potentially cause the shear bolt to break. Extended periods of overload may cause driveline damage. Excessive roller speed will also increase loose material build-up on the non-discharge side of the processor. Proper roller speed balances the feed inflow to the rotor with its discharge rate.

Rotation Direction

Turn the bale counter-clockwise (as viewed from the tractor seat) as much as possible. Reverse only as necessary to clear loose material. When turning counter-clockwise, feed flows over the hoop grate, through the rotor, and out the discharge area. When turning clockwise, material is fed both over the rotor and over the non-discharge bale roller into the rotor. This can cause overloading and vibration.

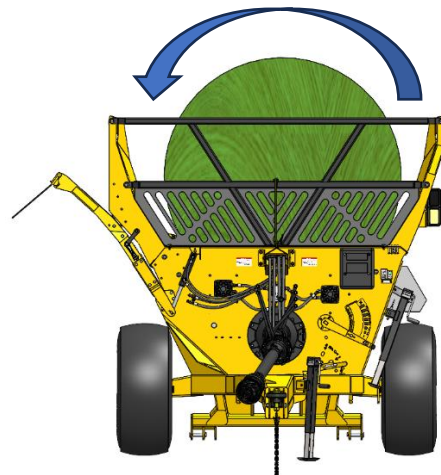

Deflector

The Bale King 6300 is equipped with a hydraulic side deflector to change the discharge distance and distribution. It also comes with a flipping rubber flap for superior control of the spread pattern.

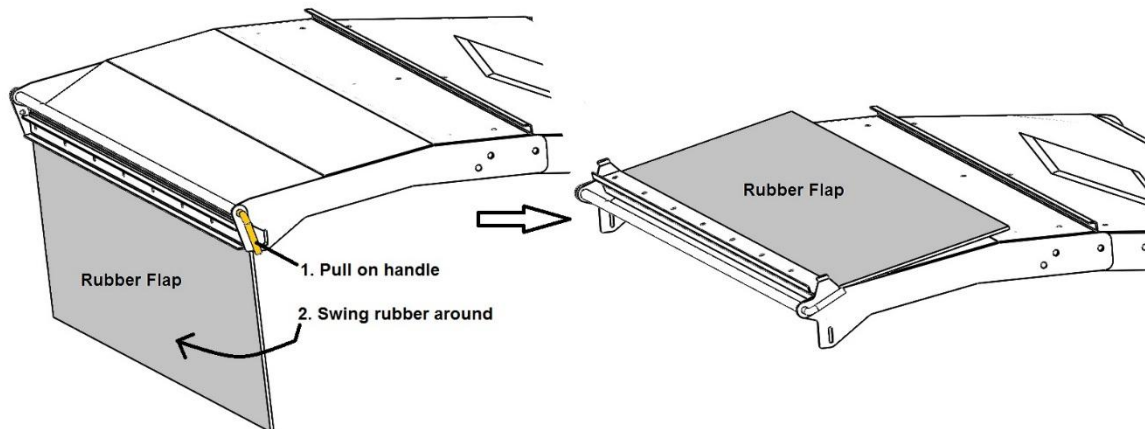

Moving the deflector to the **down** position and flipping the rubber down (above left) will allow the hay to be laid in a windrow, or bunk feeder. Swinging the deflector **up** will allow you to spread straw out over a large area. If you also flip the rubber up (above right), you will be able to "fine tune" the discharge, to control the height and distance.

To flip the rubber, simply pull on the handle and swing into position. Then push the handle so that the tabs catch in the notches and lock into place.

The Bale King 6300 deflector will bunk feed to a distance of 35" from the tire when in the lowest position. When the deflector is not folded, the transport width of the machine is 9'-10".

For transport and storage, the deflector lock should be put in place by swinging the lock as shown and fastening with a lynch pin.

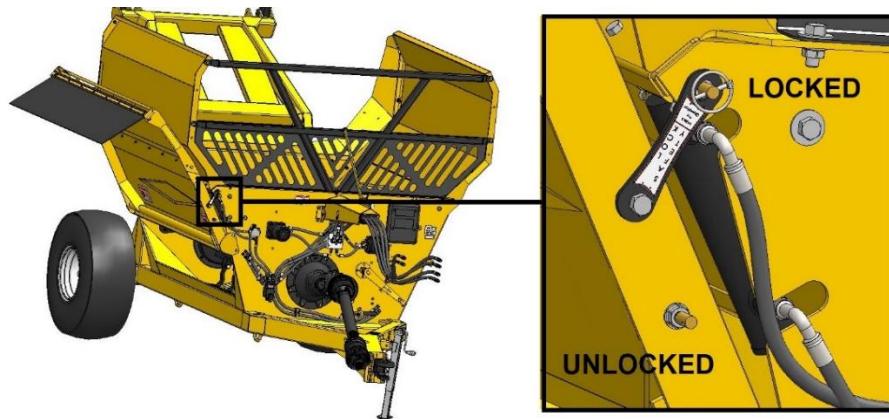

The Bale King 6300 deflector also has the ability to fold for more compact long-term storage or long-distance transport.

- Move the deflector to its lowest position
- Remove the 7 top carriage bolts from the deflector.
- Loosen all the 4 bolts on the front and back of the deflector.
- Raise the deflector to its highest position with the hydraulics. Remove the bolts closest to the machine center (both front and back) and swing the outer deflector down.

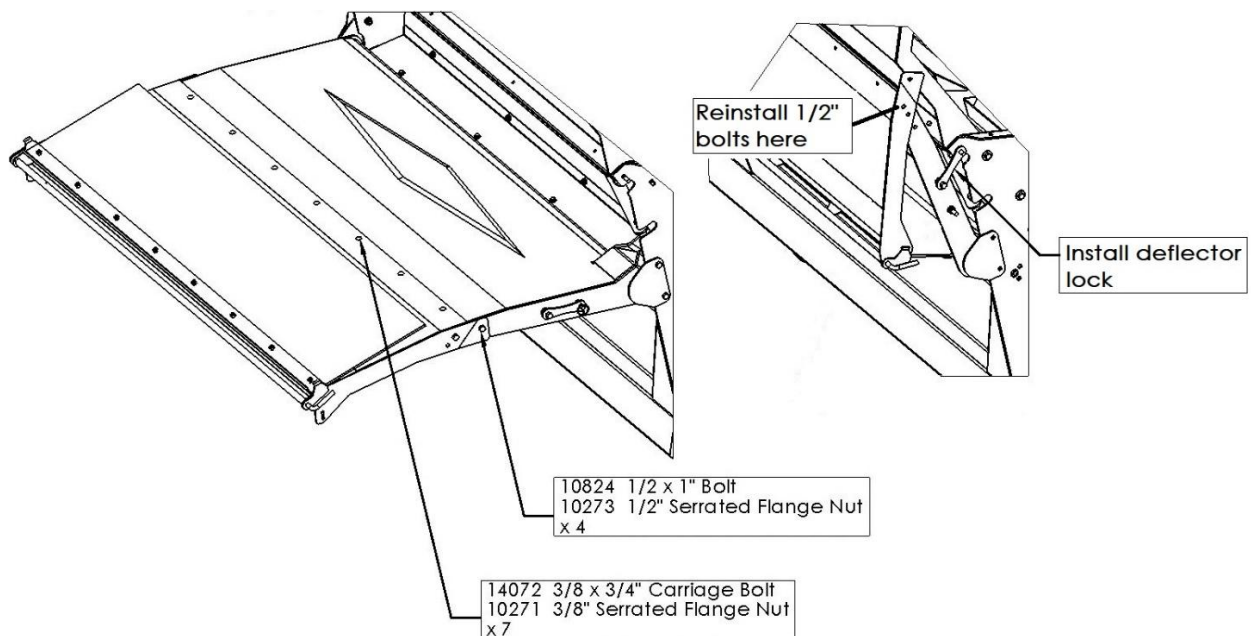

Optional Fine Chop Kit

6300	Fine Chop Option	BMI #36155
------	------------------	------------

The Bale King 5400 processor has an optional fine chop knife kit available to install into the lower tub area. This option is available if you desire a finer cut on the material which you are processing such as slough hay and silage bales.

It is recommended that the knives be disengaged when bedding straw as it will affect your spread pattern. Adjust the machine as needed.

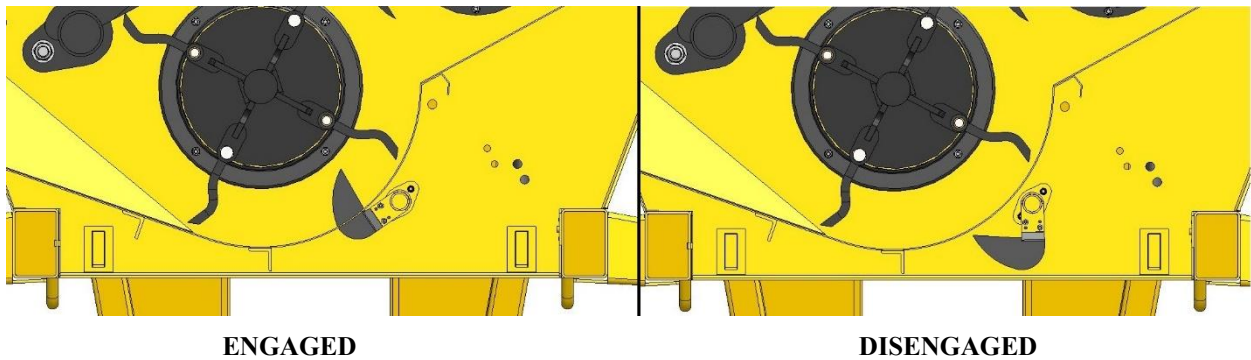

There are two settings for the fine chop, depending on how fine you wish to cut the material. These settings can be achieved by pulling out the handle, then selecting the desired hole.

0	Disengaged
1	Partially Engaged
2	Fully Engaged

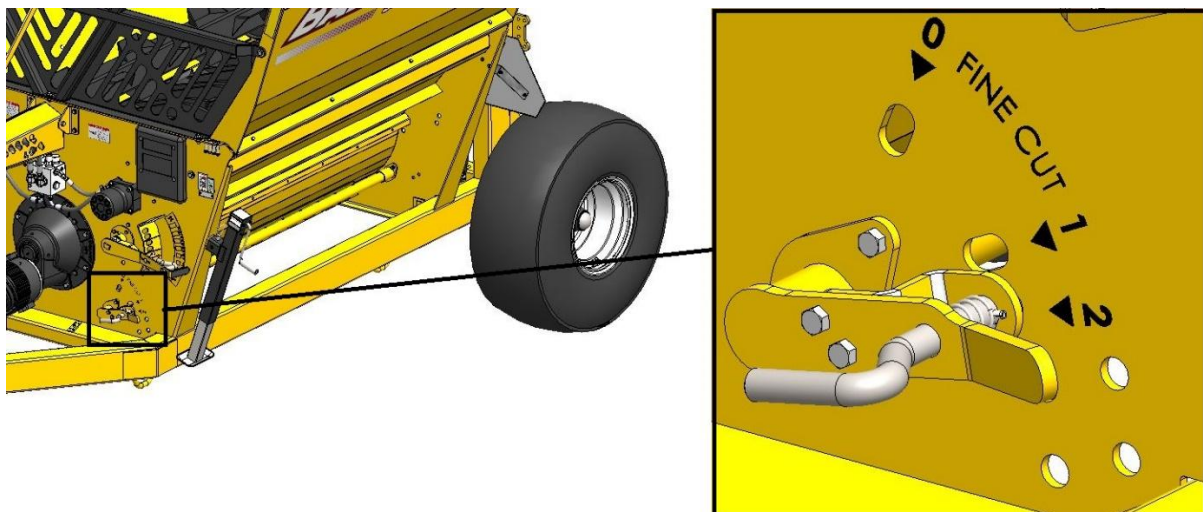

Optional Total Ration Grain Tank (6300TR)



The Bale King 6300 has an available 40-bushel grain tank, which allows grain to be discharged on top of a windrow of processed hay, or independently out the right side of the machine. This bolt-on kit changes the processor to a 6300TR (Total Ration).

The tank is located on the left side of the machine and features a large opening, 5 ft off the ground for easy filling. A flow control valve allows you to adjust the speed of the augers so that you can meter the grain flow for different situations. It is recommended to determine your desired rate based on driving speed and the flow rate of the tractor. Setting the valve to "0" will give no grain, while setting it to "10" will be full speed.

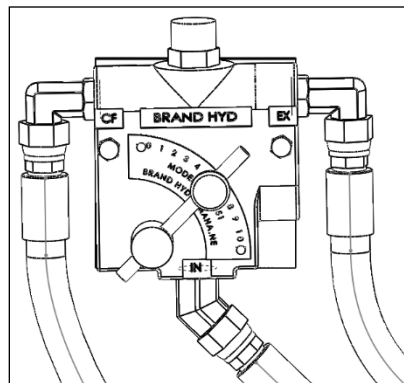

Cleanout doors are located at the bottom end of both the cross-auger, and the grain tank. It is recommended that both be cleaned out at the end of every season.

Contact Bridgeview for inquiries about adding this kit to an existing machine.

SERVICE AND MAINTENANCE

Greasing Locations

Lubricating the Bale King bale processor should be done on a regular basis.

Every 50 bales			
A	Rotor Gearbox	1	3-5 pumps
Every 150 bales			
B	Bale Fork Pivot	2	3-5 pumps
C	Deck Pivot	2	5 pumps
D	Deck Lift Cylinders	2	3-5 pumps
E	Deck Chain Idler	2	2 pumps
F	Hoop Handle	1	2 pumps
G	PTO Cross & Bearings	4	5 pumps
	PTO Guard Bushings	2	5 pumps
	PTO Spline	1	8-10 pumps
Every 500 bales (or Annually)			
G	PTO CV Joint	1	30 pumps
H	Roller Bearings *	2	3-5 pumps (DO NOT OVERGREASE)
I	Rotor Bearing *	1	3-5 pumps (DO NOT OVERGREASE)
J	Jack	1	8 - 10 pumps
Annually			
K	Wheel Hubs	4	Pack hubs full

* DO NOT OVERGREASE BEARINGS. GREASE SHOULD NOT COME THROUGH THE SEALS

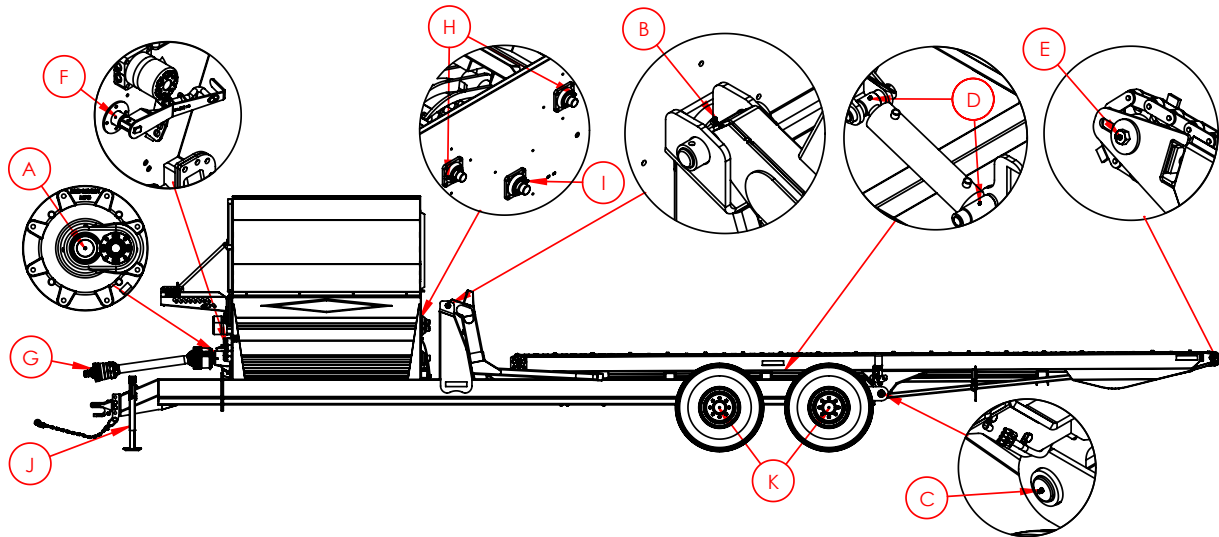

PTO/Driveline

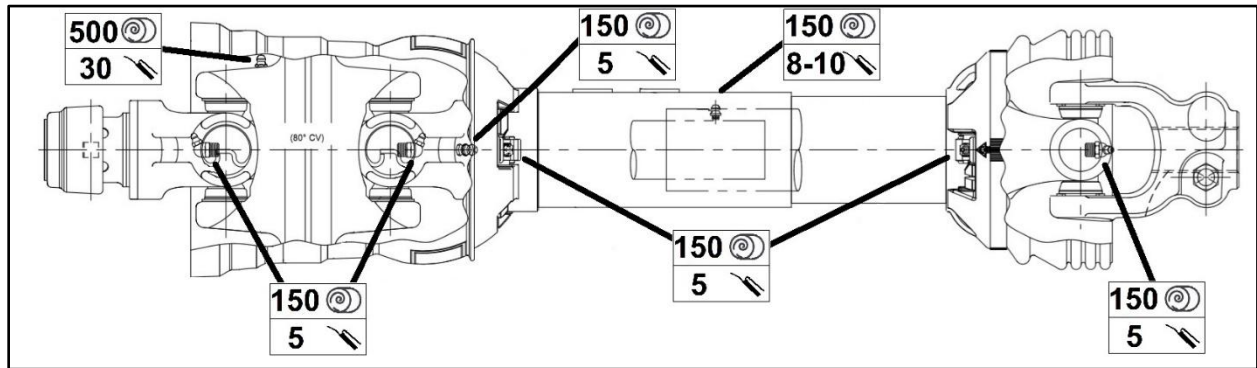

After storage for long periods of time, lubricate and check the function of every driveline component before operating. Failure to grease all the joints will **VOID** warranty.

All zerks can be accessed while the PTO is connected to the tractor EXCEPT for the telescoping spline, which can only be accessed when the PTO is fully retracted.

If operating in very cold temperatures (below -20°C or -5°F), low temperature grease (ex. EP-1 synthetic) should be used, especially where the splines overlap. This will make extending / retracting the shaft much easier and relieve stress from turning.

Inspect the joints, and ensure that there is no excessive play in any of the joints.

Inspect the shielding. Make sure that all shields are in place and functioning properly.

Gearbox

There is one grease zerk on the front of the gear box. Apply 3-5 pumps of good quality grease every 50 bales.

If the gearbox is removed to replace the rotor or perform any other service, add **80 pumps** of grease to the grease zerk upon reinstallation.

The gear box requires GL5 80W90 gear oil. The oil should be filled to the level plug (approximately **500 mL**) and checked on a regular basis. The oil should also be changed at the following intervals:

- 250 bales after first use
- Every 2000 bales afterwards, or annually (whichever comes first)

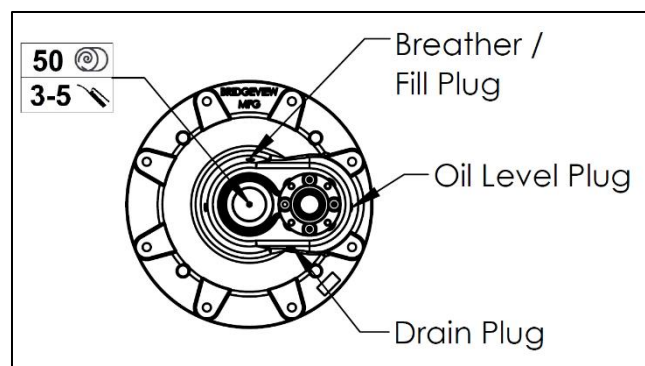

Hydraulic Maintenance

The hydraulic cylinders are easily removed for repair or maintenance simply by:

- Lowering the fork (or deflector) to the down position and unhooking the hydraulic lines. Be sure there is no pressure on the lines and mark the line locations so there is no confusion when reinstalling the cylinders. Check hydraulic schematics.
- Removing the cotter pin closest to the frame of the machine and removing the cylinder pins.
- To reinstall, reverse the removal procedure

NOTE: *Always cover exposed cylinder shafts with grease to avoid rusting of shafts if the unit is not used for extended periods of time. Rusted cylinder shafts are NOT covered by warranty*

The valves should be checked periodically to ensure that they are still functioning correctly. Contaminants in the oil may jam inside the fine ports of the valves and prevent proper function. In this case, the valve may need to be taken apart and cleaned, or replaced entirely.

NOTE: *Check all hoses and fittings periodically for leaks. Tighten or replace any dripping components or any worn out hoses.*

Wheels & Tires

Wheel bearings should be inspected annually for adjustment and lubricated annually. Inspect more often for extensive traveling.

- Lift up each wheel (one at a time) until the wheel spins freely.
- Check for excessive wheel end play by pulling and pushing the tire towards and away from you. Slight end play is acceptable.
- Rotate the tire both directions. It should turn freely and smoothly, with no excessive play, grinding noise, or “sticky” spots.

To repair the wheel bearing:

- Remove the wheel.
- Remove dust cap and the cotter pin which retains the castle nut. Unscrew the castle nut and remove the spindle washer.
- Pull the entire hub (including both bearings and the inside seal) off of the spindle.
- Clean and inspect all parts. Do not contaminate with dirt, etc.
 - If the bearing presents any pitting or corrosion then the bearing must be replaced. The bearing cup inside the hub must be inspected. When replacing bearing, they should be replaced in sets.
 - If the bearing is good, repack it with grease.
 - Whenever the hubs are removed, inspect the seal to ensure that it is not nicked or torn and is still capable of properly sealing the bearing cavity. If there is any question of condition, replace the seal.

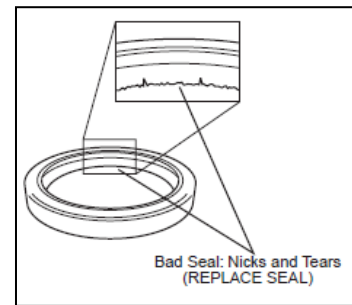

- Reassemble the seal and bearings into the hub, then install back on the spindle. Make sure the bearings and hub cavity are full of grease.
- Install the spindle washer, and the castle nut. Tighten the nut to about 50 ft-lb. Then back the nut off until the wheel will rotate approximately two turns when given a firm spin.
- Align castle nut to closest hole and insert the cotter pin.
- Pack hub full of grease, and spin to check that everything is good.
- Reinstall the dust cap.
- Reinstall the wheels and torque the wheel nuts to 125 ft-lb. This should be rechecked after a day of use to ensure the nuts do not come loose.

Proper tire inflation will help to alleviate puncture problems when towing and operating on rough terrain. Examine the tires for cuts, bruises, cracks, bulges, and penetrations.

Check for proper tire inflation	35 psi
Replace any damaged or worn tires	14Lx16.1SL 12-ply
Check and tighten wheel bolts on a regular basis	125 ft.lb

Note: Warranty does not cover damaged rims and hubs due to loose wheel bolts or flat tires.

Tire warranty is covered by the tire manufacturer.



Note: When inflating tires, use a clip-on chuck and extension hose long enough to allow you to stand to one side and NOT in front of or over the tire assembly.

Twine Removal

It is natural that twine from the bales will wrap around the rotor as they are being processed. It is recommended to remove the twine from the rotor every 10-15 bales to avoid having so much that it begins to hinder the flail movement. The more often this is done, the easier it is to remove, since the twine has not had a chance to wrap more tightly. The patented “X” shape makes twine removal much easier.

WARNING: Before attempting the removal of twine from the rotor, be sure that the machine is stopped and the tractor is shut **OFF**. Place the tractor in park. Twines can be removed with the use of the optional knife, or any other knife.

An electric device is also available from suppliers to melt the twine & allow it to be pulled off. Once melted, the twine should be removed immediately to prevent damage to the rotor. It is **NOT PERMITTED** to leave the twine burning on the rotor as this has several adverse effects:

- It may take the temper out of the steel, rendering it weaker.
- Loose straw and hay remaining in the machine may ignite causing a fire in the processor.
- Excessive buildup of melted plastic.
- Dry out bushings causing them to wear prematurely.

NOTE: *Bridgeview Manufacturing Inc. VOIDS warranty for any damage caused by twine burning in the processor.*



Twine guards are installed on the machine to keep bale twine out of important areas such as bearings.

- The wheel hubs have a twine guard to keep anything from getting tangled in the wheel bearing. Check for and remove any twine which may have wrapped around the spindle.
- The main rotor and the rollers are equipped with removable twine guards. The guards are mounted to inside of the front and rear walls of the machine. The twine guards are bolted and need to be removed if you need to remove or tighten the bolts on the bearings or the hydraulic motors.
- Remove any twine which may have wrapped around the rollers.

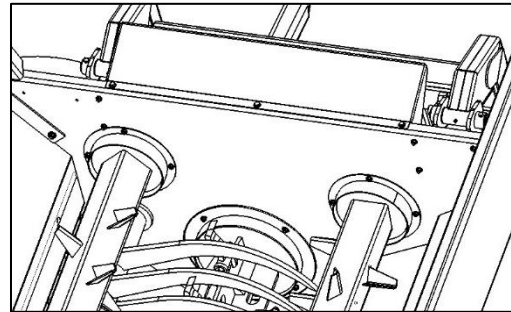

Feeding Chain

Lubricate the 2 chains with dry graphite every 50 hours of work and before a long period of storage. Rotate the chain so that both sides

Chain Adjustment Procedure

Check the tension on both chains.

- Locate the middle of the deck.
- Apply 30 lbs of pull on the chain and measure one inch between the chain and the deck.
- Loosen the axles on the idler wheel.
- To tighten the chain, turn the adjustment nut clockwise on the idler wheel until you have the right tension.
- Tighten the nut on the idler wheel.

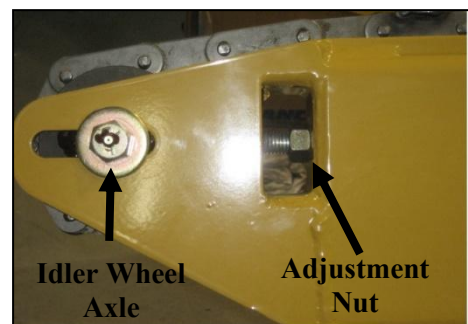

Gearbox and Flail Replacement Procedure

Flail replacement is accomplished by removing the 3/4" x 4-3/4" bolt holding the flail to the rotor. The flail is then lifted away from the rotor. The bushing can now be removed by using slight pressure to push it out of the flail. Inspect the bolt, bushing, and the flail for wear. If wear is excessive, replace with new parts (**see pg. 38**).

Bridgeview Manufacturing Inc. recommends when changing flails to change in **PAIRS** (opposite each other). Processing bales with broken flails causes the rotor to be out of balance and excessive vibration may cause machine deterioration.

If a new rotor is required, care must be taken when reinstalling:

- Clean the spline and shaft ends of the rotor of any debris
- Clean the inside of the gearbox. Check the splines for damage.
- Slide rear twine guard over the rotor
- Install new rotor bearing (if necessary). Torque to **200 ft-lb**
- Slide the rotor through the rear bearing. Do not tighten collar yet
- Install the gearbox over the rotor spline and bolt to the tub
- Check flail clearance of **1/2 to 5/8"** to tub panel
- Center the rotor in the tub so that the flails are centered between the hoops and slots
- Tighten bearing lock collar **counter-clockwise**. Apply *loc-tite* to the set screw and torque to **100 in-lb**.
- Check gearbox oil to the side plug level (~500 mL). Replace if necessary.
- Add **80 pumps** of grease to the front gearbox grease zerck.
- Install rear twine guard using 3/8" bolts.

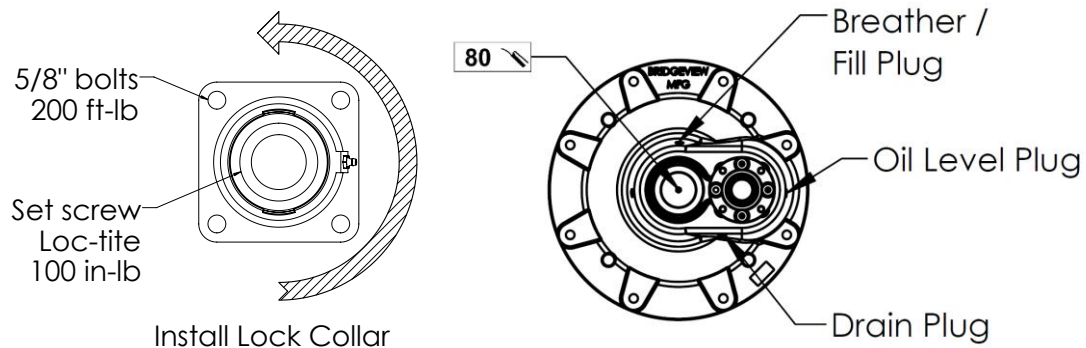
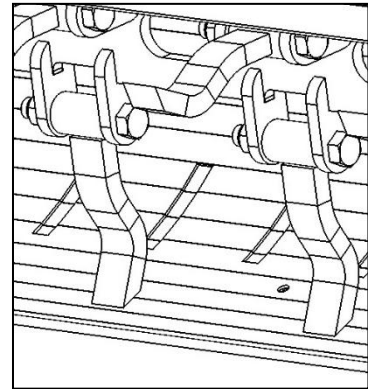

Trouble-shooting Guide

Problem	Possible Cause	Remedy
Excessive vibration while processing bales	Overloading rotor	<ul style="list-style-type: none"> • Set hoops to less aggressive position • Slow rotation of bale • Change direction of bale rotation (counter clockwise as much as possible)
	Operating machine at less than 1000 PTO RPM	<ul style="list-style-type: none"> • Operate machine at rated 1000 PTO RPM
	Broken flails causing rotor to be out of balance	<ul style="list-style-type: none"> • Replace broken flails (in pairs opposite each other)
	Excessive twine wrapped on rotor causing flail movement to be restricted	<ul style="list-style-type: none"> • Cut twine off rotor
	Rotor bearing failure	<ul style="list-style-type: none"> • Replace failed parts
Excessive shear bolt breakage	High machine vibration	<ul style="list-style-type: none"> • See above
	Engaging PTO at high engine speed or too quickly	<ul style="list-style-type: none"> • Idle tractor to engage PTO then bring up to full operating speed • Feather PTO lever into position
	Excessive horsepower	<ul style="list-style-type: none"> • Use smaller tractor (Max 150 HP)
	Incorrect shear bolt used	<ul style="list-style-type: none"> • Use correct shear bolt
Bale not turning	Excessive loose material in tub causing roller to jam	<ul style="list-style-type: none"> • Reverse direction of bale rotation to clean out • Turn bale more slowly
	Rotary straw bale bridging across rollers	<ul style="list-style-type: none"> • Install rotary straw assist kit
	Second bale interfering	<ul style="list-style-type: none"> • Lower fork slightly
	Tractor relief pressure set too low	<ul style="list-style-type: none"> • Set tractor relief pressure to at least 2500 PSI
A single roller stopping	Mechanical flow divider valve not functioning correctly	<ul style="list-style-type: none"> • Contact your dealer for repairs
	Coupler between motor and roller broken	<ul style="list-style-type: none"> • Replace failed parts
No grain Flow (Total Ration only)	Flow control valve set too low	<ul style="list-style-type: none"> • Increase flow rate in tractor or on flow control valve
	Flow control valve relief pressure set too low	<ul style="list-style-type: none"> • Use hydraulic pressure gauge to ensure relief pressure is set to 2200psi. • Ensure sufficient pressure from tractor
	Auger chute at too shallow of an angle for grain to clear fast enough	<ul style="list-style-type: none"> • Run auger slower • Run chute at steeper angle
A single chain stopping	Mechanical flow divider valve not functioning correctly	<ul style="list-style-type: none"> • Contact dealer for repairs
	Sprocket is broken, or motor shaft has failed	<ul style="list-style-type: none"> • Replace failed components
	Chain has slipped off the sprocket	<ul style="list-style-type: none"> • Reinstall chain and check tension (pg. 28)
Deflector or tilt functions do not work	Control box is not plugged in	<ul style="list-style-type: none"> • Plug in the control box. Needs power from the tractor.
	Control box is not connected	<ul style="list-style-type: none"> • Plug the control box to the 4-pin plug on the processor
	Control box fuse has failed	<ul style="list-style-type: none"> • Replace the fuse

Features and Specifications

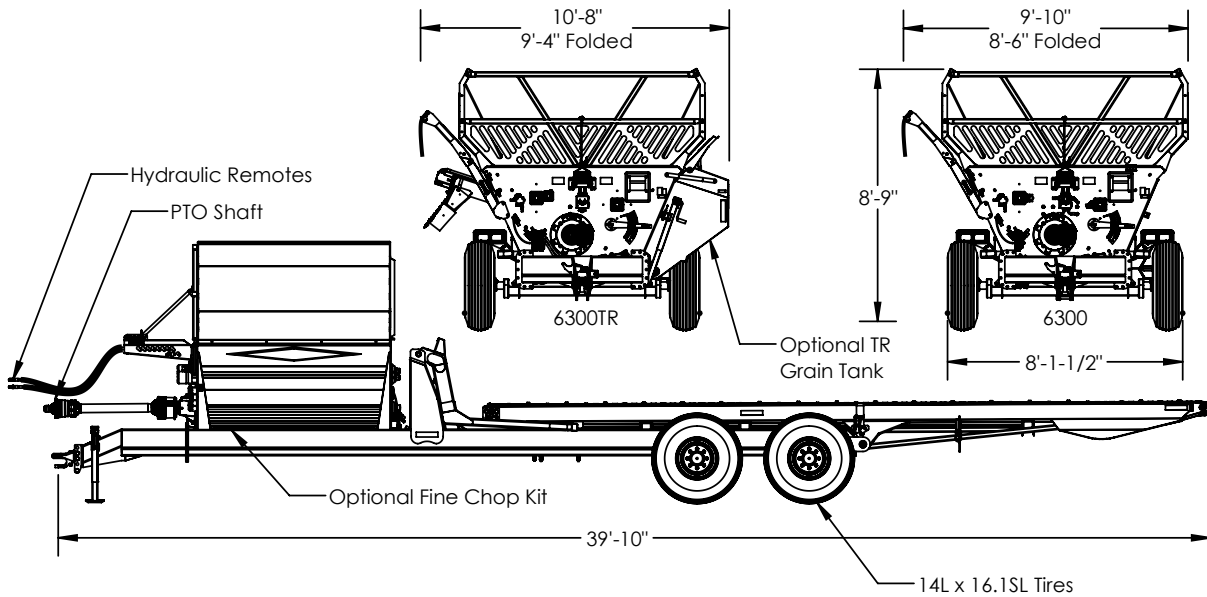

Dimensions:	6300	6300TR
Overall Weight	9060 lb	9700 lb
Drawbar Weight	3100 lb	3400 lb
Overall Width (Deflector Down)	11'-4"	12'-3"
Grain Tank Capacity		40 bushels
Rotor Extended Tip Diameter		27 in.
Discharge Opening		12 x 80 in.

Wheels:

Tire Size	14L x 16.1SL 12-ply
Tire Inflation	35 psi
Wheel Nut Torque	125 ft-lb

Driveline:

Minimum Horsepower	100 HP
--------------------	--------

*Ensure sufficient horsepower for terrain driven.

PTO Shaft	Weasler: Cat. 6 80 deg. C.V.
Shear Bolt	3/8 x 2" Fine Thread Gr. 5
Rated PTO RPM	1000 RPM
Flail Tip Speed at 1000 RPM	7000 FPM
Number of Flails	28
Flail Size	3/4 x 1-1/2 x 7 in.
Flail Bushing	Oil Impregnated Brass
Rotor Shaft	1-15/16" Bearing
Gearbox Oil	GL5 80W90
Gearbox Oil Capacity	500 mL

Hydraulics:

Required Remotes	3 Standard (with Diverter)
Minimum Flow Requirements	15 GPM
Minimum Pressure Requirements	1800 psi

Other:

Roller Shaft	1-3/4" Bearings
Twine Guards	Rotor, Rollers, Axles
Adjustable Bale Fork Width (on centers)	48 in. or 40.5 in.
Adjustable Hitch Height	3 settings at 2.25 in. intervals (13" -17.5")
Discharge deflector	Adjustable top and bottom Removable rubber end flap

PARTS MANUAL

Machine Overview	34
Jack & Hitch	35
Wheels & Hub.....	36
Spindle	37
Rotor & Drive Components	38
Gearbox.....	39
PTO Shaft.....	41
Grates	42
Rollers.....	44
Deflector & Hose Cover	45
Top Tub Components	47
Rear Forks.....	48
Front Tub Components	49
Hose Holder	50
Rear Tub and Hydraulic Components.....	51
Bale Deck.....	52
Chain Motor Assembly	53
Idler Sprocket Assembly.....	54
Lights and SMV Sign.....	55
Decals.....	57
Total Ration Grain Tank Option.....	62
Total Ration Tank Front.....	63
Total Ration Tank Rear.....	65
Total Ration Cross Auger	67
Total Ration Tank Lid.....	69
Fine Chop Option.....	70
Twine Cutter Option	74
Diverter Control Box	75
Hydraulic Schematics	80
NOTES.....	89

Machine Overview

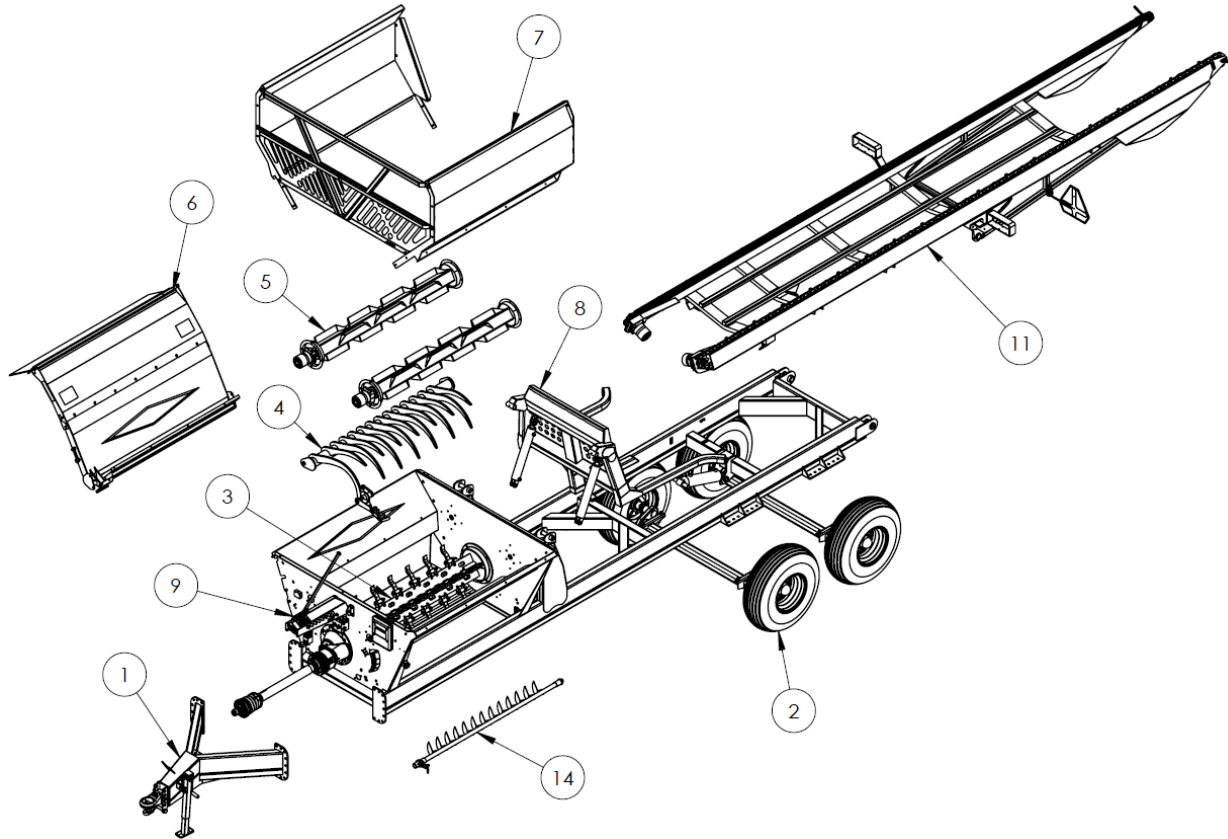

1	Jack & Hitch	Page 35	10	Rear Tub Components	Page 51
2	Wheels & Hub	Page 36	11	Bale Deck	Page 52
3	Rotor & Drive Components	Page 38	12	Decals	Page 57
4	Grates	Page 42	13	Total Ration Grain Tank Option	Page 62
5	Rollers	Page 44	14	Fine Chop Option	Page 70
6	Deflector & Hose Cover	Page 45	15	Twine Cutter Option	Page 74
7	Top Tub Components	Page 47	16	Diverter Control Box	Page 75
8	Rear Forks	Page 48	17	Hydraulic Schematics	Page 80
9	Front Tub Components	Page 49			

**** CHECK YOUR SERIAL NUMBER BEFORE ORDERING PARTS ****
**** PAY ATTENTION TO SERIAL NUMBER SPLITS WHERE INDICATED ****
**** LEFT / RIGHT AS DESCRIBED ARE VIEWED FROM THE REAR ****

Per Quantities: A/R = As Required
 Per ID#: NSS = Not Sold Separately

Jack & Hitch

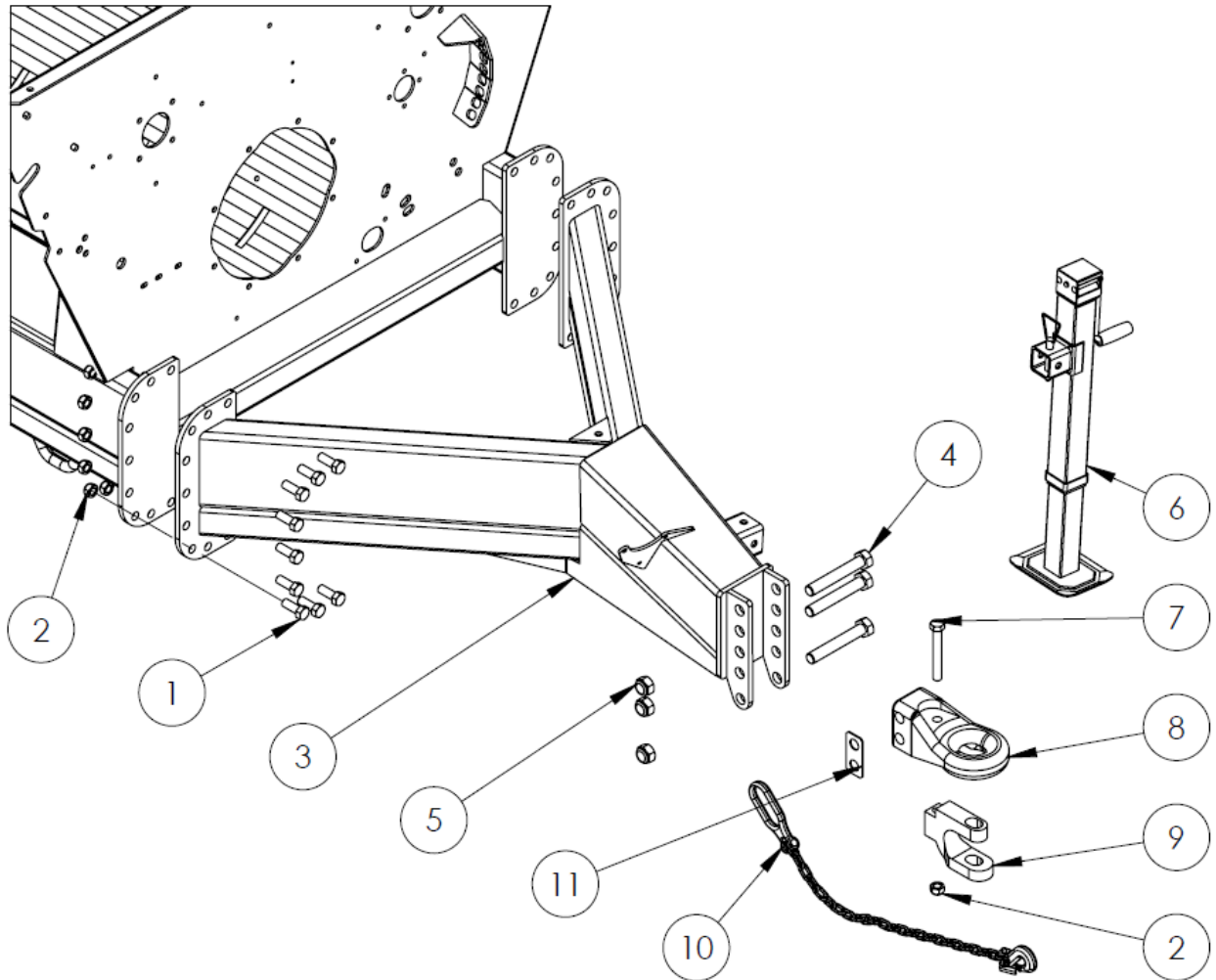

#	DESCRIPTION	PART #	QTY
1	Bolt, 3/4 x 2"	13800	18
2	Nut, 3/4" Stover Lock	11823	18
3	Hitch Frame	35562	1
4	Bolt, 1 x 6-1/2"	28426	3
5	Nut, 1" Stover Lock	21746	2
6	Jack, 7000 lb	35250	1
	Comes with pin		
7	Bolt, 3/4 x 5-1/2"	26406	1
8	Hitch Tongue	23404	1
9	Hitch Clevis Kit	25540	1
	Includes 2 & 7		
10	Safety Chain, 21000lb x 52"	23559	1
11	Hitch Shim	35926	A/R
	10 gauge	35927	
	12 gauge	35928	
	14 gauge	35928	
	16 gauge	35929	

Wheels & Hub

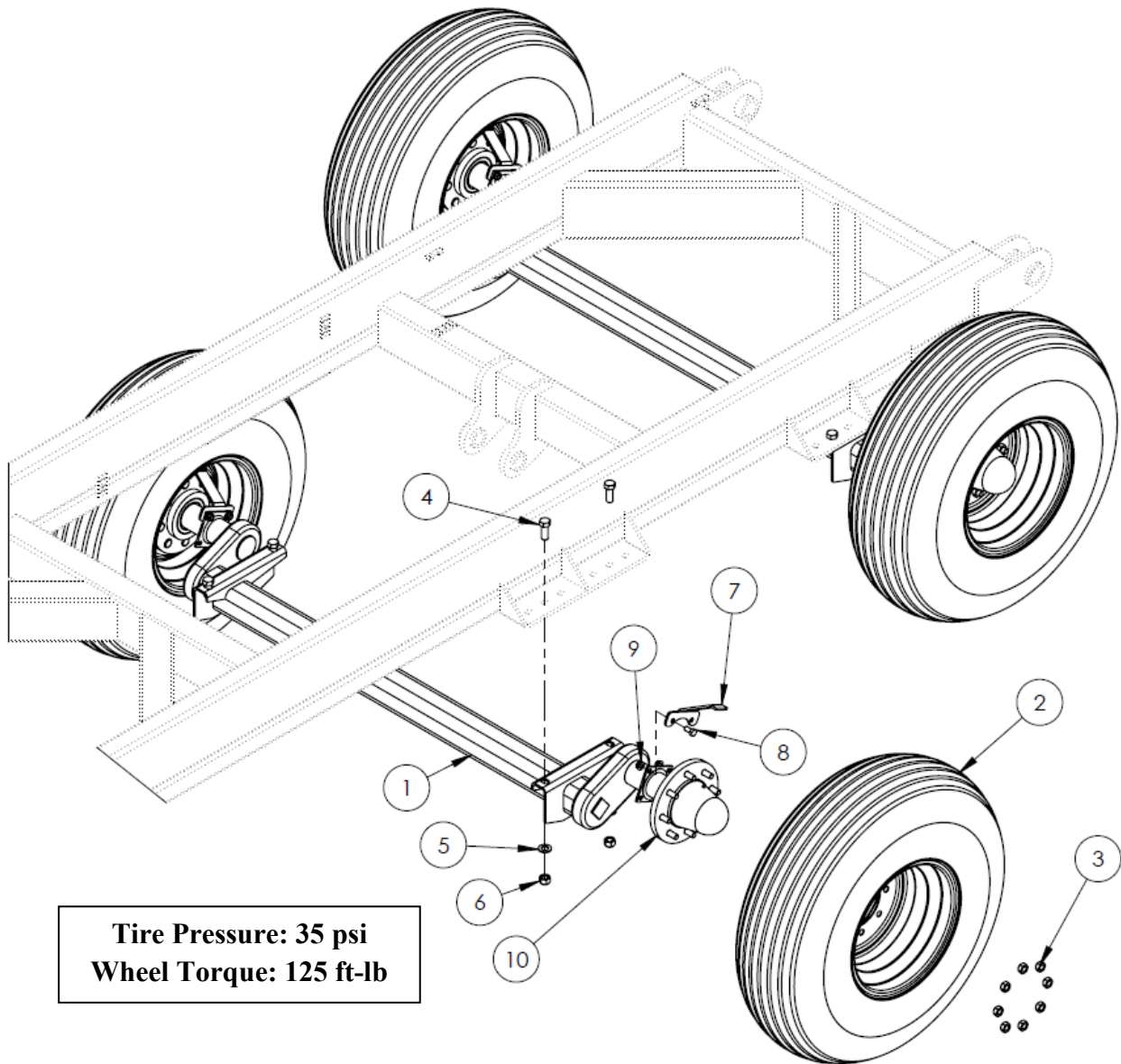

Tire Pressure: 35 psi
Wheel Torque: 125 ft-lb

#	DESCRIPTION	PART #	QTY
1	Torflex Axle, 8000#	22850	2
2	Tire & Rim, 14L-16.1SL (12 Ply)	See your local tire dealer NSS	4
3	Wheel Nut	23183	32
4	Bolt, 3/4 x 2"	13800	8
5	Washer, 3/4" Flat	13717	8
6	Nut, 3/4" Stover Lock	11823	8
7	Twine Guard	23744	4
8	Bolt, 1/2" x 1-1/4"	10240	8
9	Nut, 1/2" Serrated Flange	10273	8
10	Hub Assembly	See breakdown next page	

Spindle

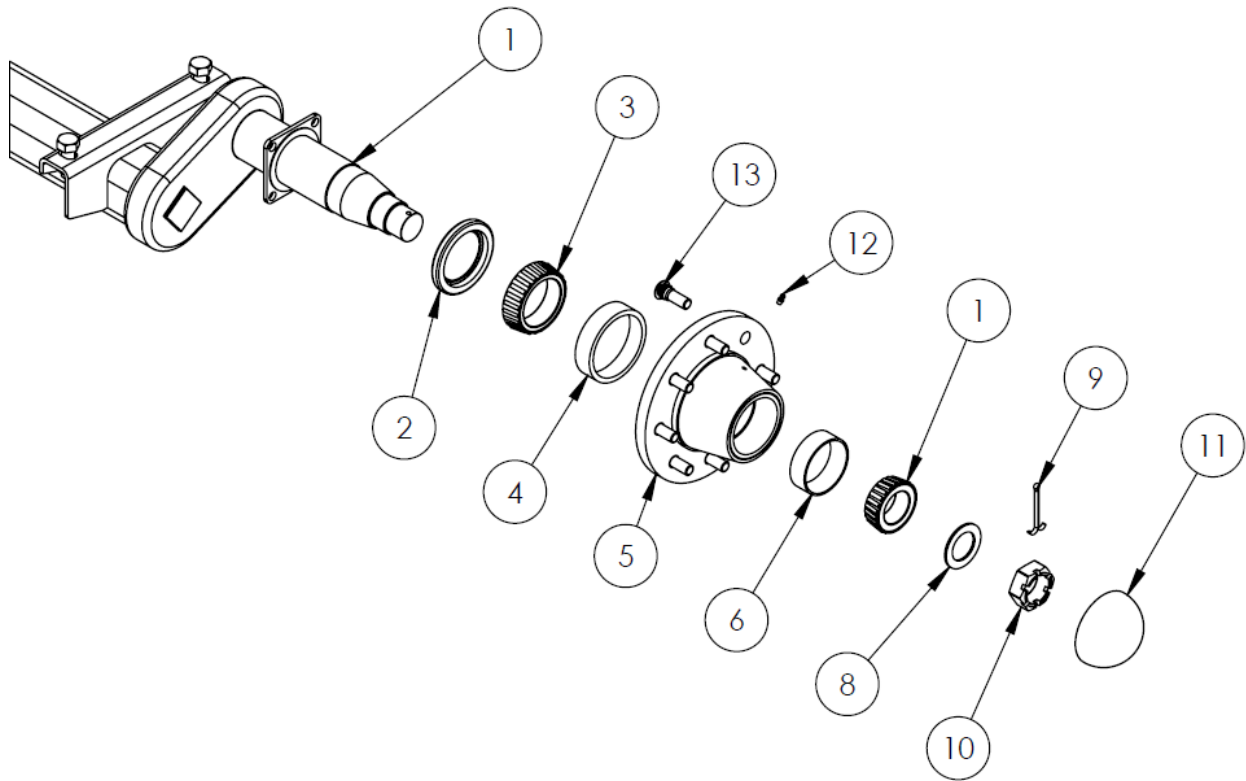

#	DESCRIPTION	PART #	QTY	
1	Complete Torflex Axle Assembly	22850	1	
2	Seal	23569	1	
3	Inner Bearing	JLM506849	23567	1
4	Inner Bearing Race	JLM506810	23571	1
5	Hub Housing	Includes 4,6,12 & 13	23572	1
6	Outer Bearing Race	LM501310	23570	1
7	Outer Bearing	JLM501349	23568	1
8	Spindle Washer		23564	1
9	Cotter Pin, 5/32 x 2"		23565	1
10	Castle Nut		23566	1
11	Dust Cap		23563	1
12	Grease Zerk		10270	1
13	Wheel Stud		23573	8

NOTE: Quantity is per hub

Rotor & Drive Components

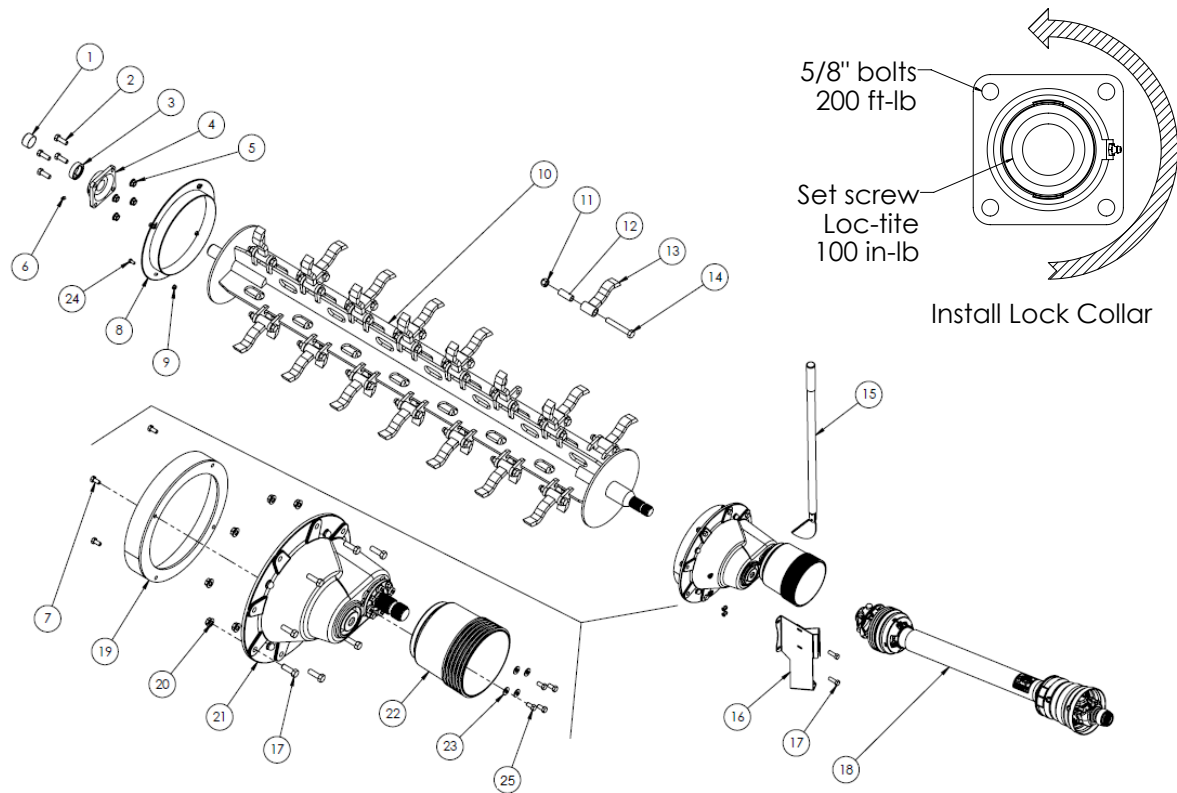

#	DESCRIPTION	PART #	QTY	
1	Rotor Shaft Cap	17380	1	
2	Bolt, 5/8" x 1-3/4" NF Gr. 8	10274	4	
3	Lock Collar	10268	1	
4	Rotor Bearing	Includes # 3 & 6	10221	1
5	Nut, 5/8" NF Serrated Flange Gr. 8	15398	4	
6	Grease Zerk, 1/8" NPT Straight	10270	1	
7	Bolt, 3/8" x 3/4"	11816	4	
8	Rotor Twine Guard, Rear	22413	1	
9	Nut, 3/8" Serrated Flange	10271	4	
10	X-Rotor Weldment	22449	1	
11	Nut, 3/4" Stover Lock	11823	28	
12	Brass Flail Bushing	10005	28	
13	Rotor Flail	REPLACE IN PAIRS	22412	28
14	Bolt, 3/4" x 4-3/4"	10443	28	
15	OPTIONAL Twine Cutter	See Breakdown	-	
16	OPTIONAL Twine Cutter Holder	See Breakdown	-	
17	Bolt, 1/2" x 1-1/2"	10174	8	
18	PTO Shaft	See Breakdown	-	1
19	Gearbox Twine Guard	23002	1	
20	Nut, 1/2" Stover Lock	20154	8	
21	Gearbox Assembly	See Breakdown	-	1
22	PTO Safety Shield	34899	1	
23	Flat Washer, 3/8"	11667	4	
24	Bolt, 3/8 x 1"	13806	4	
25	Bolt, M10 x 16	25154	4	

Gearbox

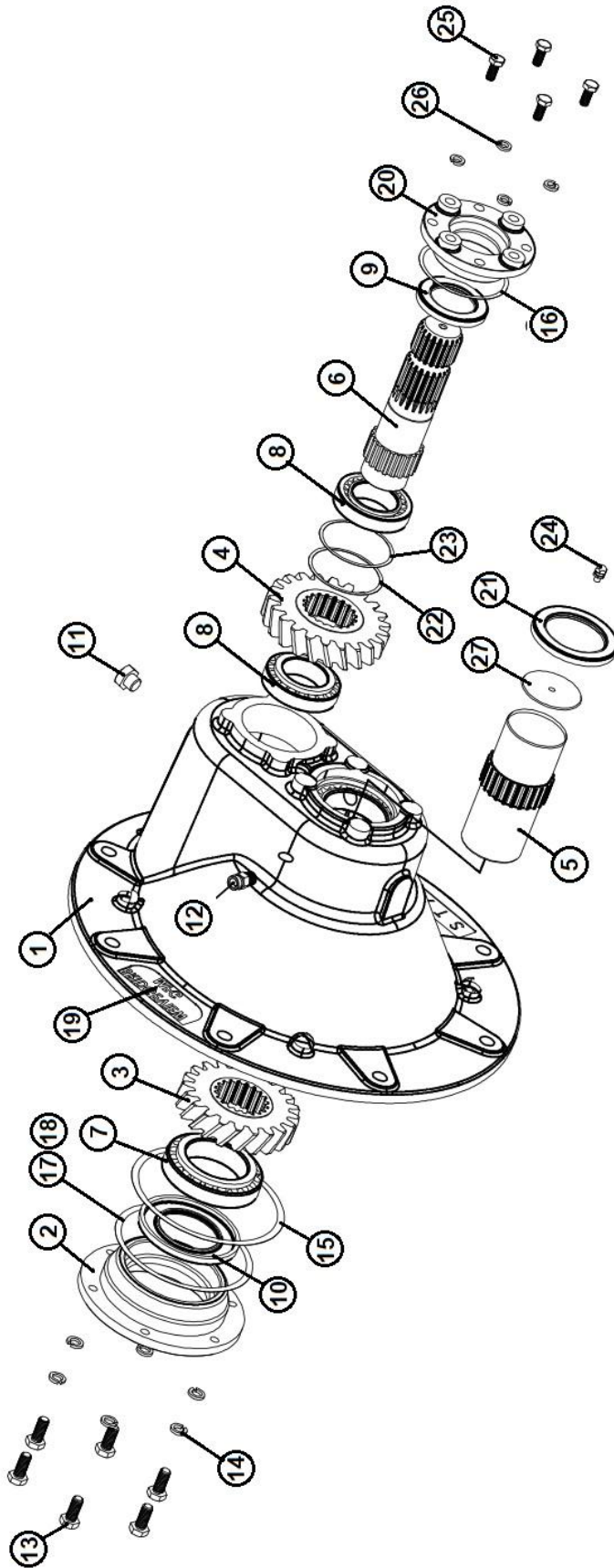

Gearbox

#	DESCRIPTION	PART #	QTY
	Complete Gearbox Assembly	22158	1
1	Housing	-	1
2	End Cap	-	1
3	Output Gear	-	1
4	Input Gear	-	1
5	Output Shaft	-	1
6	Input Shaft	-	1
7	Bearing (32012) 60mm	10496	2
8	Bearing (32009) 45mm	10497	2
9	Seal, 45 x 60 x 8	24013	1
10	Seal, 60 x 100 x 10	10498	1
11	Pipe Plug, 3/8" NPT	24014	2
12	Relief Plug, 3/8" NPT	24015	1
13	Bolt, M8 x 25 Gr. 8.8	24026	6
14	Lock Washer, M8	24016	6
15	O-Ring	24017	1
16	O-Ring	24018	1
17	Shim, 125 x 164 x 0.1	24022	2
18	Shim, 125 x 164 x 0.3	24023	2
19	Name Plate (Bridgeview)	-	1
20	End Cap	-	1
21	Seal, 60 x 85 x 10	10500	1
22	Shim, 68 x 74.5 x 0.1	24024	2
23	Shim, 68 x 74.5 x 0.3	24025	2
24	Grease Zerk, 1/4"-28 Straight	26219	1
25	Bolt, M10 x 25	15087	4
26	Lock Washer, M10	24021	4
27	Press Cup	24446	1

NOTE: Items with no part number are not sold separately. A complete gearbox is required.

PTO Shaft

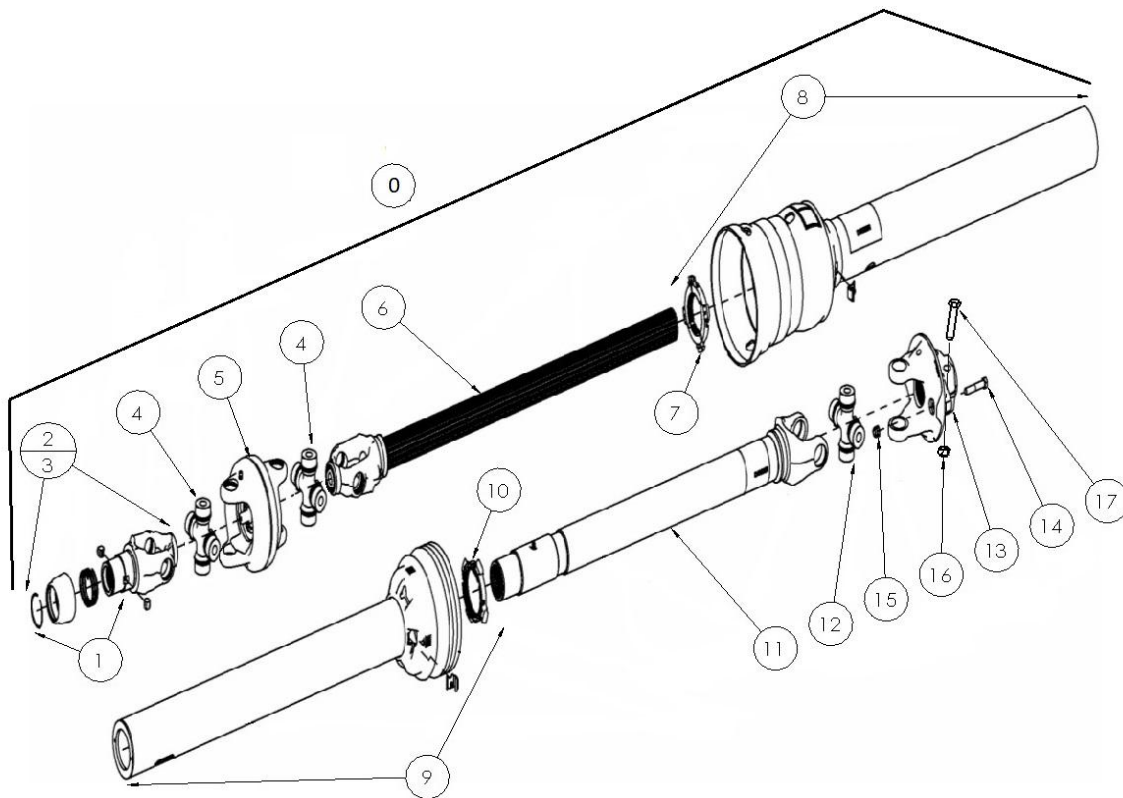

#	DESCRIPTION	PART #	QTY
	Complete PTO Shaft Assembly (1-3/8")	20546	1
0a	Tractor Half PTO Assembly (1-3/8"-21 Spline)	32505	1
0b	Tractor Half PTO Assembly (1-3/4"-20 Spline)	32506	1
1a	Safety Slide Lock Repair Kit (1-3/8"-21 Spline)	17567	1
1b	Safety Slide Lock Repair Kit (1-3/4"-20 Spline)	24981	1
2	WWCV Auto-Lok Yoke Assembly (1-3/8"-21 Spline)	20549	1
3	WWCV Auto-Lok Yoke Assembly (1-3/4"-20 Spline)	20556	
4	CV Cross and Bearing Kit (Equal Length)	20550	2
5	CV Center Housing	20551	1
6	Yoke & Shaft Assembly Tractor Side	20552	1
7	Guard Repair Kit Tractor Side	20553	1
8	Guard Assembly Tractor Side	17583	1
9	Guard Assembly Implement Side	17585	1
10	Guard Repair Kit Implement Side	17572	1
11	Yoke & Tube Assembly Implement Side	17584	1
12	U-joint Cross & Bearing Kit	17573	1
13	Shear Assembly * Does not come with bolts 14 or 17 *	29963	1
14	Shear Bolt, 3/8" x 2" Fine Thread	33285	1
15	Nut, 3/8" Fine Thread Stover Lock	33286	1
16	Nut, 5/8" Stover Lock	24982	2
17	Bolt, 5/8" x 3-1/2"	24983	2

NOTE: Ensure that the PTO shaft on the machine is correct to the drawings below. Equal length CV cross (4.19") with bearing cup diameter 1.38". If the damaged PTO has different dimensions, consult the Bridgeview Manufacturing website.

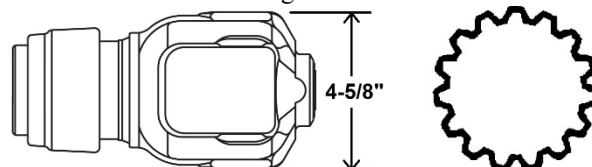

Grates

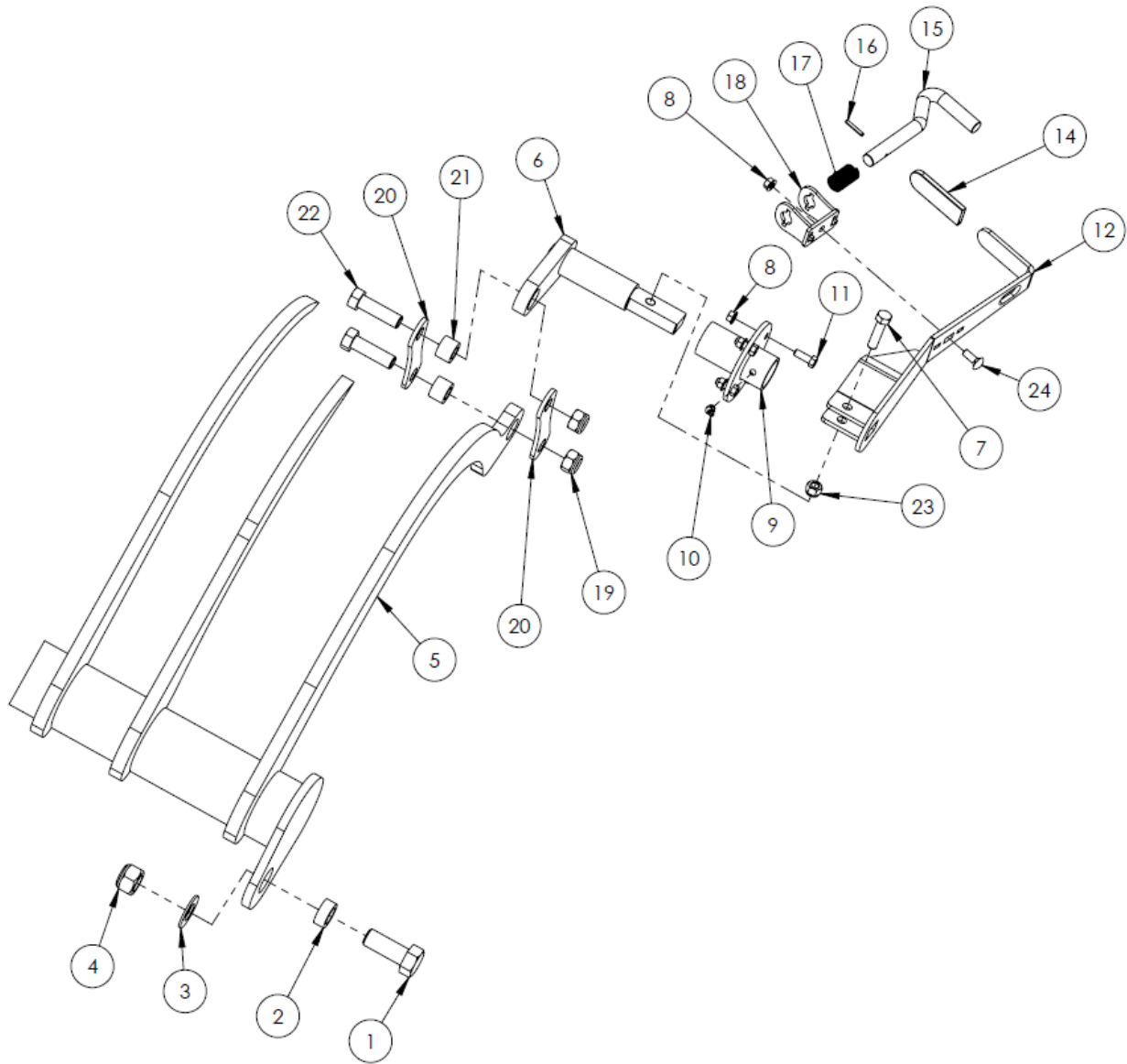

Grates

#	DESCRIPTION	PART #	QTY	
1	Bolt, 1" x 2-1/2"	21820	2	
2	Grate Pivot Bushing	22417	2	
3	Flat Washer, 1"	14472	2	
4	Nut, 1" Stover Lock	21746	2	
5	Grate Assembly	29944	1	
6	Grate Adjustment Cam	Includes #9,10	31720	1
7	Bolt, 1/2" x 2"	10322	1	
8	Nut, 3/8" Serrated Flange	10271	5	
9	Grate Handle Pivot	NSS	1	
10	Grease Zerk, 1/4"-28 x 45°	20888	1	
11	Bolt, 3/8" x 1"	13806	4	
12	Grate Handle	Comes with #18,24,8	31725	1
13	Washer, 3/8" Flat	11667	-	
14	Rubber Cover	10297	1	
15	S-Handle	22187	1	
16	Roll Pin, 3/16" x 1-1/4"	10302	1	
17	Grate Handle Spring	10301	1	
18	Handle Spring Guide	33693	1	
19	Nut, 3/4" Stover Lock	11823	2	
20	Grate Shackle	31709	2	
21	Grate Shackle Bushing	22415	2	
22	Bolt, 3/4" x 2-1/4"	29824	2	
23	Nut, 1/2" Nylon Lock	10241	1	
24	Bolt, 3/8 x 1" Carriage	15718	1	

Rollers

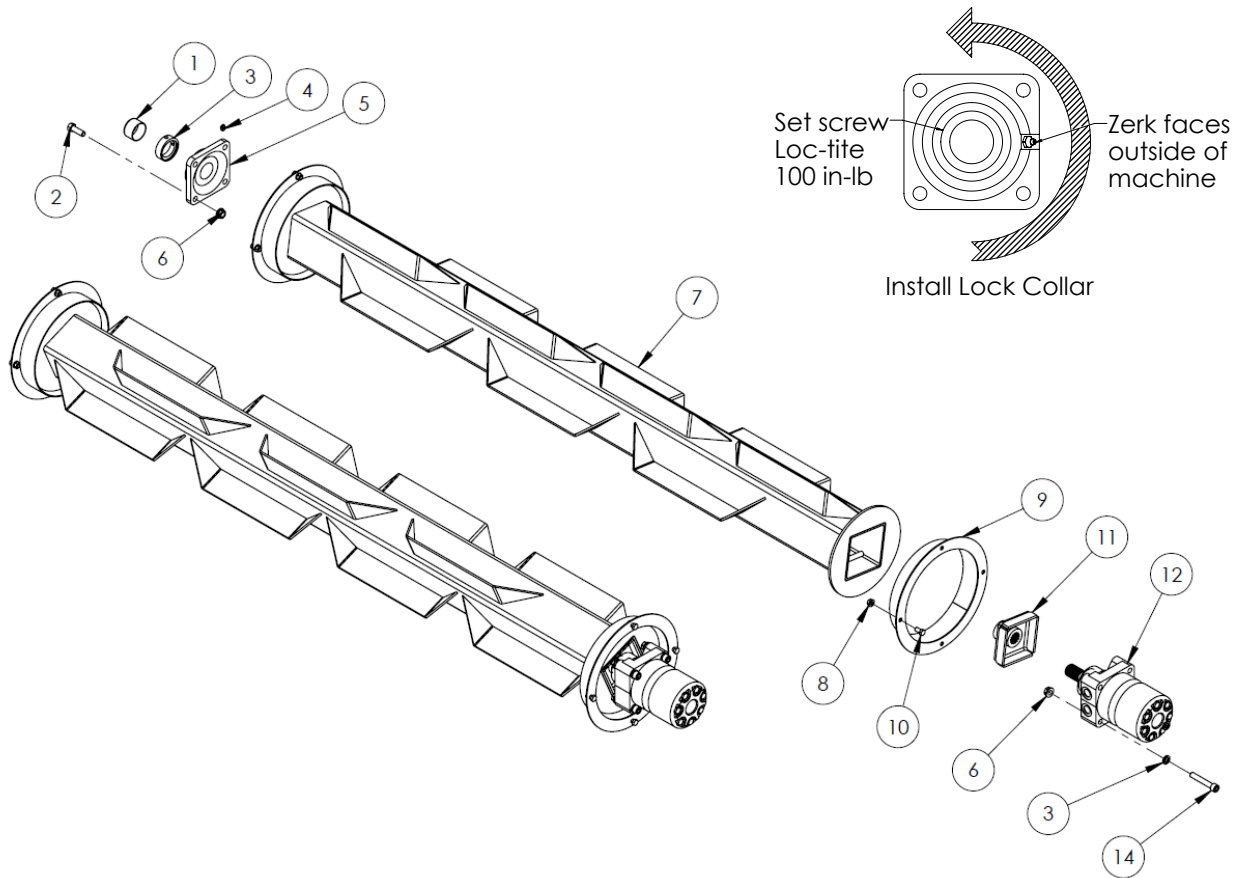

#	DESCRIPTION	PART #	QTY
1	Roller Shaft Cap	17381	2
2	Bolt, 1/2" x 1-1/2"	10174	8
3	Lock Collar	10040	2
4	Grease Zerk, 1/8" NPT Straight	10270	2
5	Roller Bearing	Includes # 3 & 4 10038	2
6	Nut, 1/2" Serrated Flange	10273	16
7	Roller	31596	2
8	Nut, 3/8" Serrated Flange	10271	16
9	Roller Twine Guard	22419	4
10	Bolt, 3/8" x 3/4"	11816	16
11	Roller Insert	22084	2
12	Roller Motor, 8" Long Seal Kit	25872 25891	2
13	Lock Washer, 1/2"	14447	8
14	Socket Head Bolt, 1/2" x 3"	25952	8

Deflector & Hose Cover

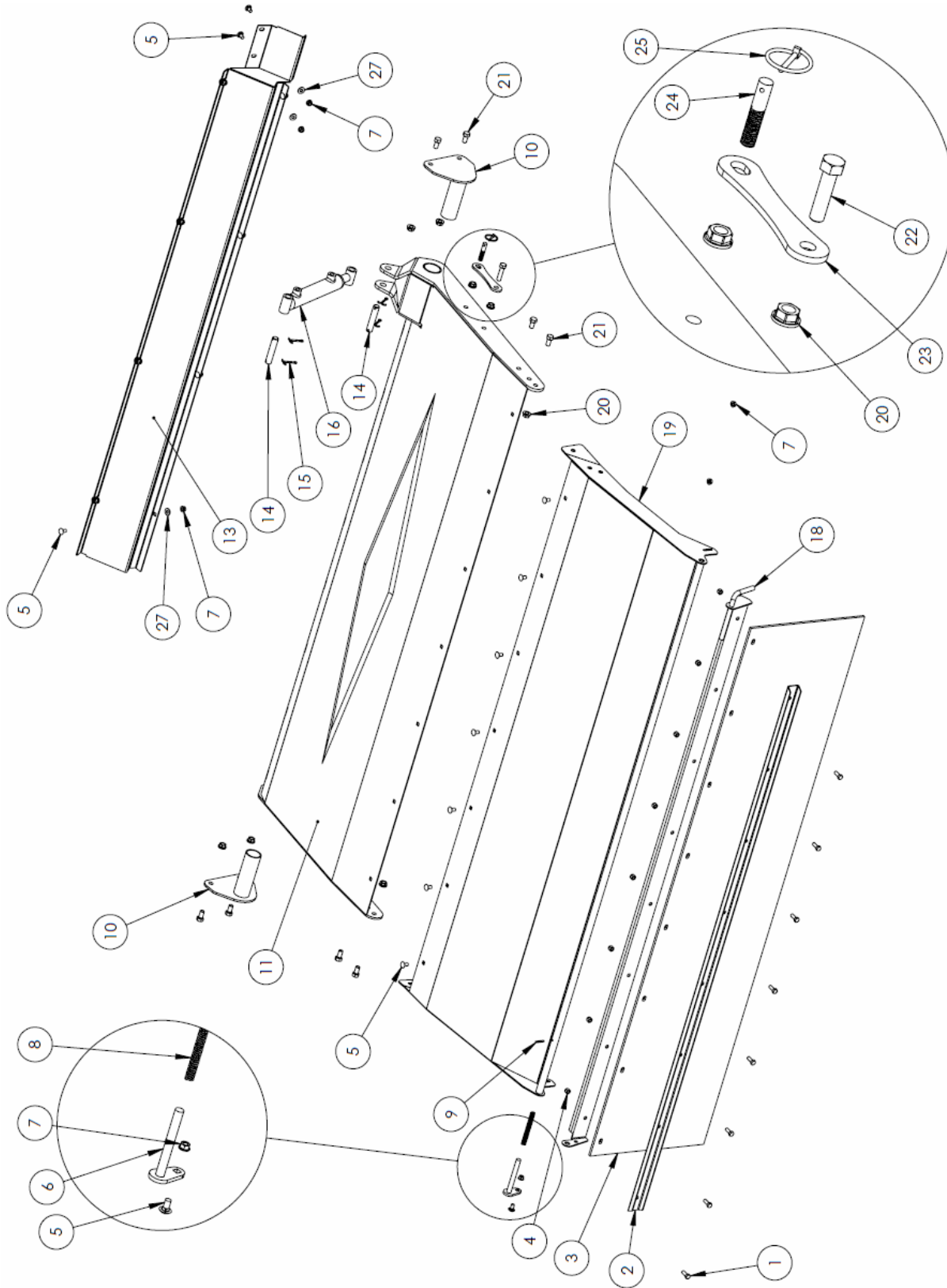

Deflector & Hose Cover

#	DESCRIPTION	PART #	QTY
1	Bolt, 3/8" x 1"	13806	8
2	Deflector Rubber Channel	22423	1
3	Deflector Rubber	10477	1
4	Nut, 3/8" Nylon Lock	10806	8
5	Carriage Bolt, 3/8" x 3/4"	14072	18
6	Deflector Flipper Pin	24464	1
7	Nut, 3/8" Serrated Flange	10271	18
8	Compression Spring	24461	1
9	Roll Pin, 3/16" x 1-1/4"	10302	1
10	Deflector Pivot	22426	2
11	Inner Deflector	32196	1
13	Hose Cover	32191	1
14	Cylinder Pin, 3/4" x 3" Usable	22007	2
15	Cotter Pin, 3/16" x 1-1/4"	11669	4
16	Hydraulic Cylinder, 1-1/2" x 6" x 1" Seal Kit	21711 23738	1
18	Deflector Rubber Flipper	24463	1
19	Outer Deflector	31754	1
20	Nut, 1/2" Serrated Flange	10273	12
21	Bolt, 1/2" x 1"	10824	8
22	Bolt, 1/2" x 2"	10322	1
23	Deflector Lock	22422	1
24	Pin Stud	13231	1
25	Lynch Pin	13233	1
27	Flat Washer, 3/8"	11667	10

Top Tub Components

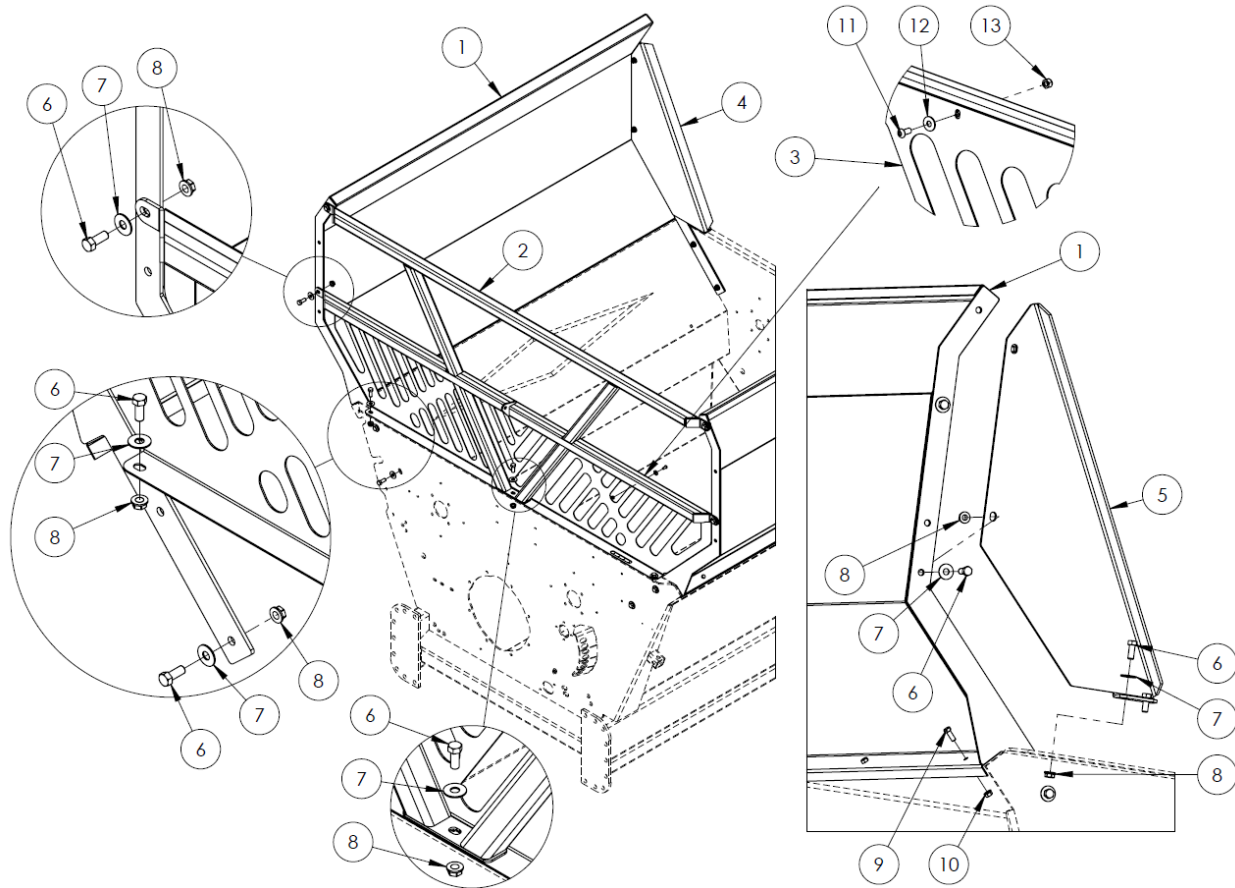

#	DESCRIPTION	PART #	QTY
1	Wing	31692	2
2	Front Rack	31730	1
3	Front Rack Grating	32479	1
4	Wing Bolt-on Bracket (Right)	22431	1
5	Wing Bolt-on Bracket (Left)	22430	1
6	Bolt, 1/2" x 1 1/4"	10240	23
7	Washer, 1/2" Flat	11668	23
8	Nut, 1/2" Serrated Flange	10273	23
9	Bolt, 3/8 x 1"	13806	8
10	Nut, 3/8" Serrated Flange	10271	8
11	Bolt, 5/16" x 3/4" Button Head	32513	8
12	Washer, 5/16" Flat	12496	8
13	Nut, 5/16" Nylon Lock	11815	8

Rear Forks

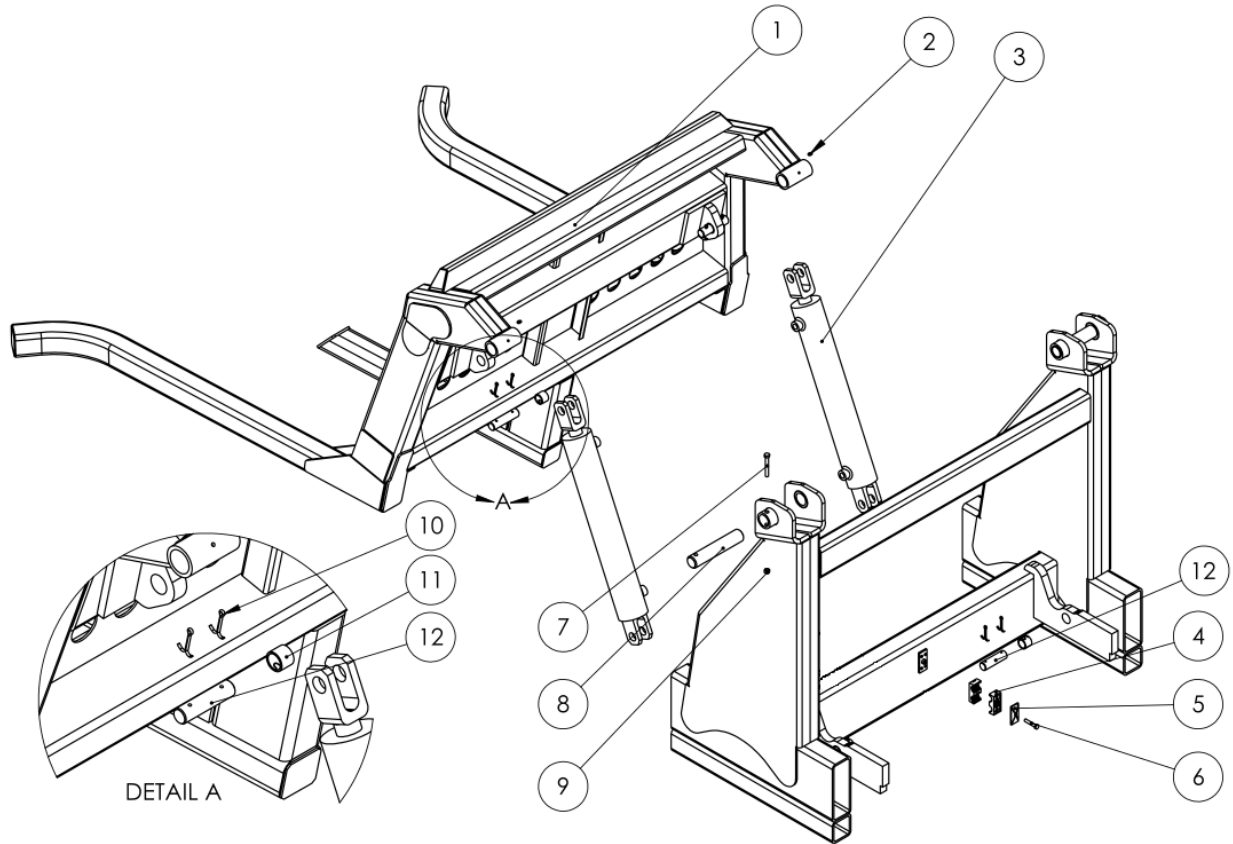

#	DESCRIPTION	PART #	QTY
1	Back Fork	30504	1
2	Grease Zerk 1/4" x 90°	16389	2
3	Hydraulic Cylinder (3 x 18 x 1.5) Seal Kit	21717 20807	2
4	Hydraulic Hose Clamp 1/2"	21561	14
5	Hose Clamp Top 1/2"	21725	7
6	5/16" x 1-3/4" Bolt	21726	7
7	3/8" x 2-3/4" Bolt	20908	2
8	Fork Pivot Pin	22006	2
9	Nut, 3/8" Nylon Lock	10806	2
10	Cotter Pin (3/16" x 1-1/2")	10072	8
11	Spring Bushing (1" Pin)	23708	4
12	Cylinder Pin (1" x 3-1/2")	10339	4

Front Tub Components

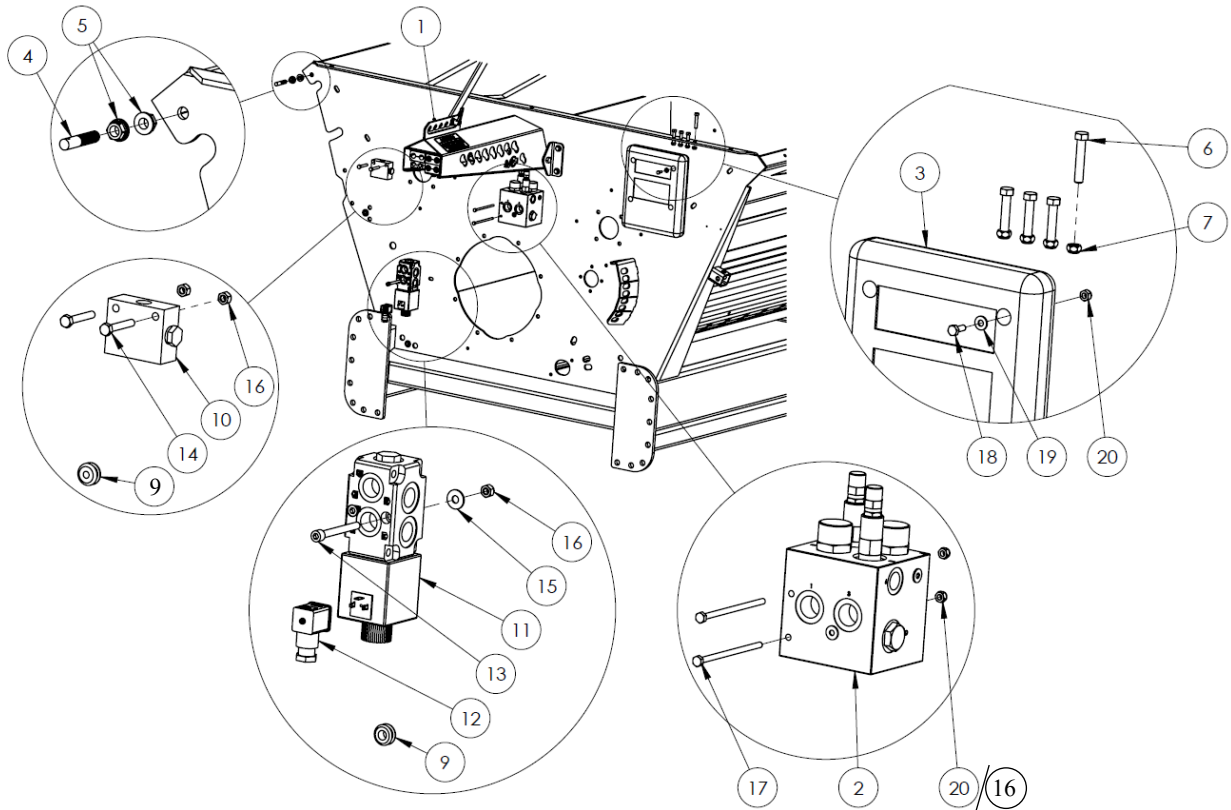

#	DESCRIPTION	PART #	QTY	
1	Hose Holder See page 50	-	-	
2	Flow Divider Valve	25778	1	
3	Operator Manual Holder	22409	1	
4	Threaded Pin	13231	1	
5	Nut, 1/2" Serrated Flange	10273	2	
6	Bolt, 3/8 x 2" Fine Thread Gr.5	PTO Shear Bolt	33285	4
7	Nut, 3/8" Fine Thread Stover Lock	PTO Shear Bolt	33286	4
8	Grommet, 5/16 x 1/4" Thick	13179	1	
9	Grommet, 7/16" x 1/4" Thick	21428	1	
10	Pilot Check Valve	19114	1	
11	Diverter Valve # Nut & O-Ring Kit Magnet Kit	11743 17977 11798	1	
12	Valve Plug	13657	1	
13	Bolt, 5/16 x 3" Socket Head	11783	2	
14	Bolt, 5/16 x 2"	15572	2	
15	Washer, 5/16" Flat	12496	2	
16	Nut, 5/16" Nylon Lock	11815	4	
17	Bolt, 5/16 x 3"	S/N BK7695 & above	36321	3
	Bolt, 1/4 x 5"	S/N BK7694 & below	25951	2
18	Bolt, 1/4 x 3/4"	11809	4	
19	Washer, 1/4" Flat	11666	4	
20	Nut, 1/4" Nylon Lock	11664	6	

NOTE: See page 75 for information on the control box

Hose Holder

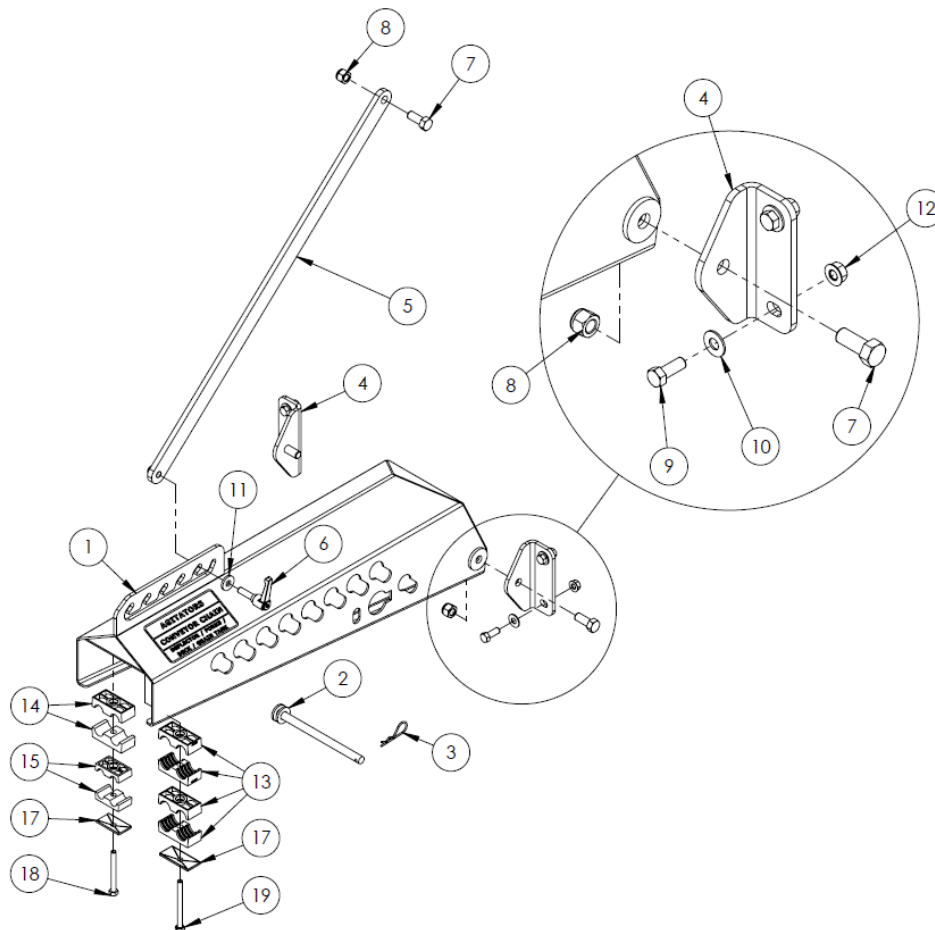

#	DESCRIPTION	PART #	QTY
1	Adjustable Hose Holder	35038	1
2	Hose Holder Pin	31745	1
3	Hairpin, 3/32 x 5/8"	11786	1
4	Hose Holder Pivot Bracket	35041	2
5	Hose Holder Linkage	35040	1
6	Threaded Adjustable Handle	34944	1
7	Bolt, 1/2 x 1-1/4"	10240	3
8	Nut, 1/2" Nylon Lock	10241	3
9	Bolt, 3/8" x 1"	13806	4
10	Flat Washer, 3/8"	11667	4
11	Flat Washer, 3/8" Heavy	33189	1
12	Nut, 3/8" Serrated Flange	10271	4
13	Hydraulic Hose Clamp, 1/2"	21561	4
14	Hydraulic Hose Clamp, 3/8"	22180	2
15	Hydraulic Hose Clamp, 1/4"	22181	2
16	Hydraulic Hose Clamp Cap, Large	21725	1
17	Hydraulic Hose Clamp Cap, Small	22182	1
18	Bolt, 5/16" x 3"	22844	1
19	Bolt, 5/16" x 3-1/2"	13765	1

Rear Tub and Hydraulic Components

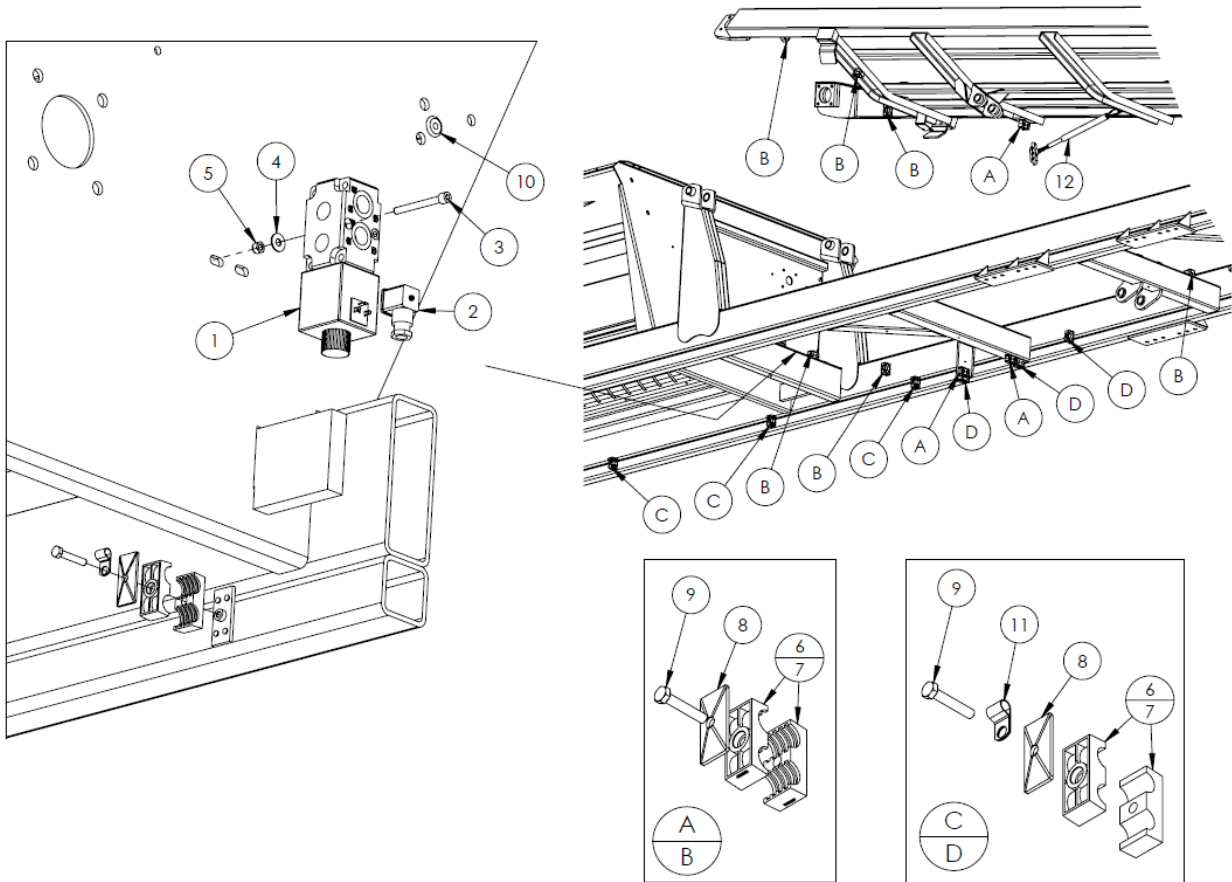

#	DESCRIPTION	PART #	QTY
1	Diverter Valve #	11743	1
	Nut & O-Ring Kit	17977	
	Magnet Kit	11798	
2	Diverter Valve Plug	13657	1
3	Bolt, 5/16 x 3" Socket Head	11783	2
4	Washer, 5/16" Flat	12496	2
5	Nut, 5/16" Nylon Lock	11815	2
6	Hydraulic Hose Clamp, 1/2"	21561	4
7	Hydraulic Hose Clamp, 3/8"	22180	2
8	Hydraulic Hose Clamp Cap, Large	21725	1
9	Bolt, 5/16" x 1-3/4"	21726	1
10	Grommet, 7/16 x 1/4" Thick	21428	1
11	Wire Clamp	13629	11
12	Spring Hose Holder	24651	1

NOTE: See page 75 for information on the control box

Bale Deck

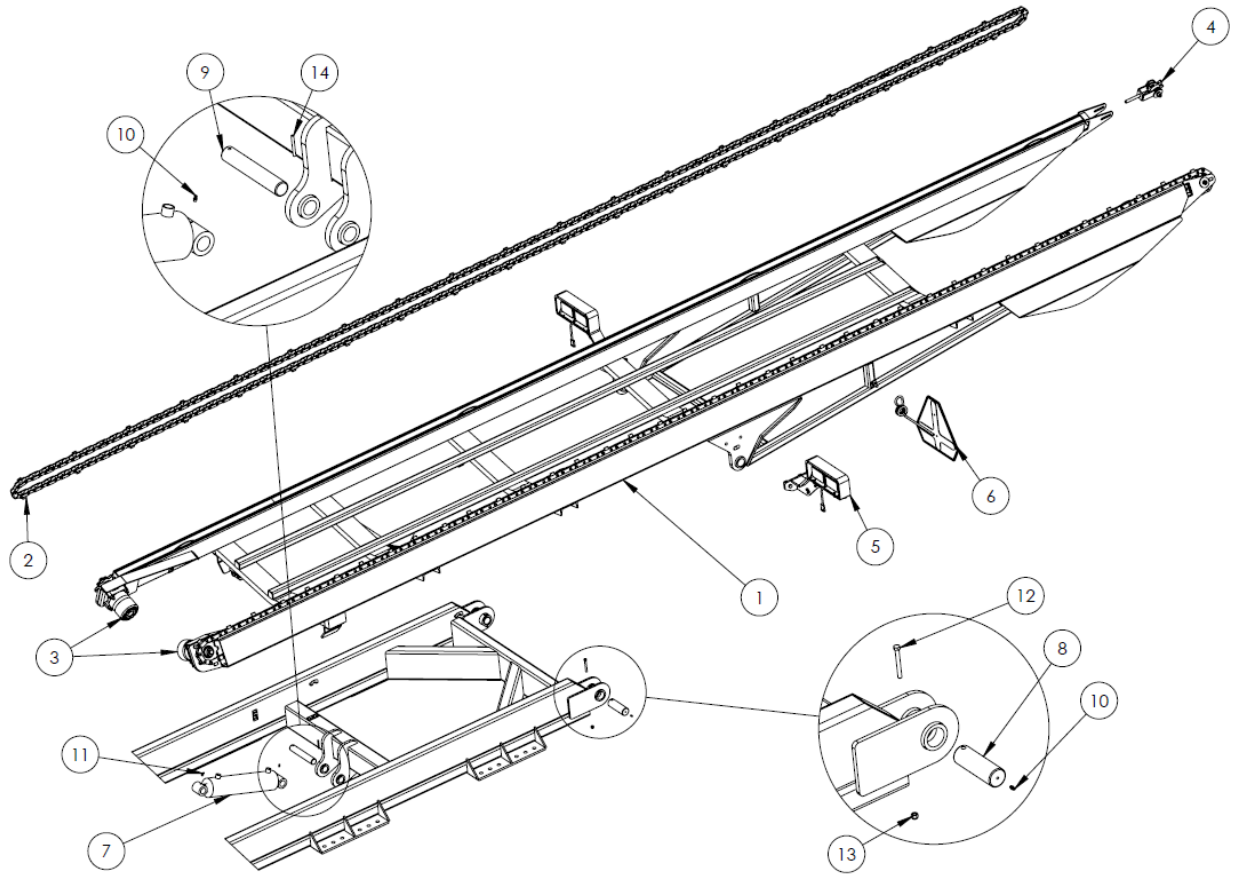

#	DESCRIPTION	PART #	QTY
1	Bale Deck	24727	1
2	2082 Chain with Tabs Connector Link	24748 23093	2
3	Chain Motor Assembly	See breakdown pg. 53	-
4	Idler Sprocket Assembly	See breakdown pg. 54	-
5	Light Assembly	See breakdown pg. 55	-
6	SMV Sign	See breakdown pg. 55	-
7	Hydraulic Cylinder, 4 x 14 x 2"	Comes with straight zerks	23094
8	Deck Pivot Pin	1-15/16 x 5-7/8"	23596
9	Cylinder Pin	1-1/2 x 8-7/8"	24132
10	Grease Zerk, 1/4"		16364
11	Grease Zerk, 1/4" x 45°		20888
12	Bolt, 3/8 x 3-1/4"		23325
13	Nut, 3/8" Nylon Lock		10806
14	Roll Pin, 1/4 x 2-1/4"		23544

Chain Motor Assembly

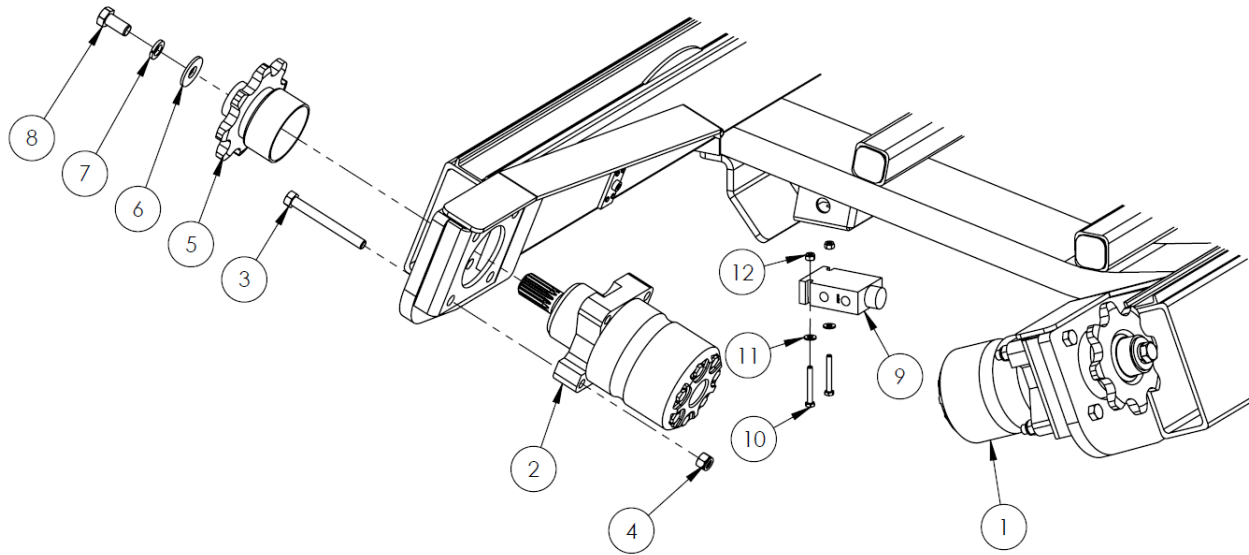

#	DESCRIPTION	PART #	QTY
1	Hydraulic Motor, Left Hand Seal Kit	28702	1
		25891	
2	Hydraulic Motor, Right Hand Seal Kit	28703	1
		25891	
3	Bolt, 1/2 x 4-1/2"	15574	8
4	Nut, 1/2" Nylon Lock	10241	8
5	Sprocket, 8 Tooth	23747	2
6	Washer, 5/8" Heavy Flat	21390	2
7	Washer, 5/8" Lock	10276	2
8	Bolt, 5/8 x 1-1/4" NF	13328	2
9	Flow Divider Valve	11742	1
10	Bolt, 1/4 x 2"	11663	2
11	Washer, 1/4" Flat	11666	2
12	Nut, 1/4" Nylon Lock	11664	2

Idler Sprocket Assembly

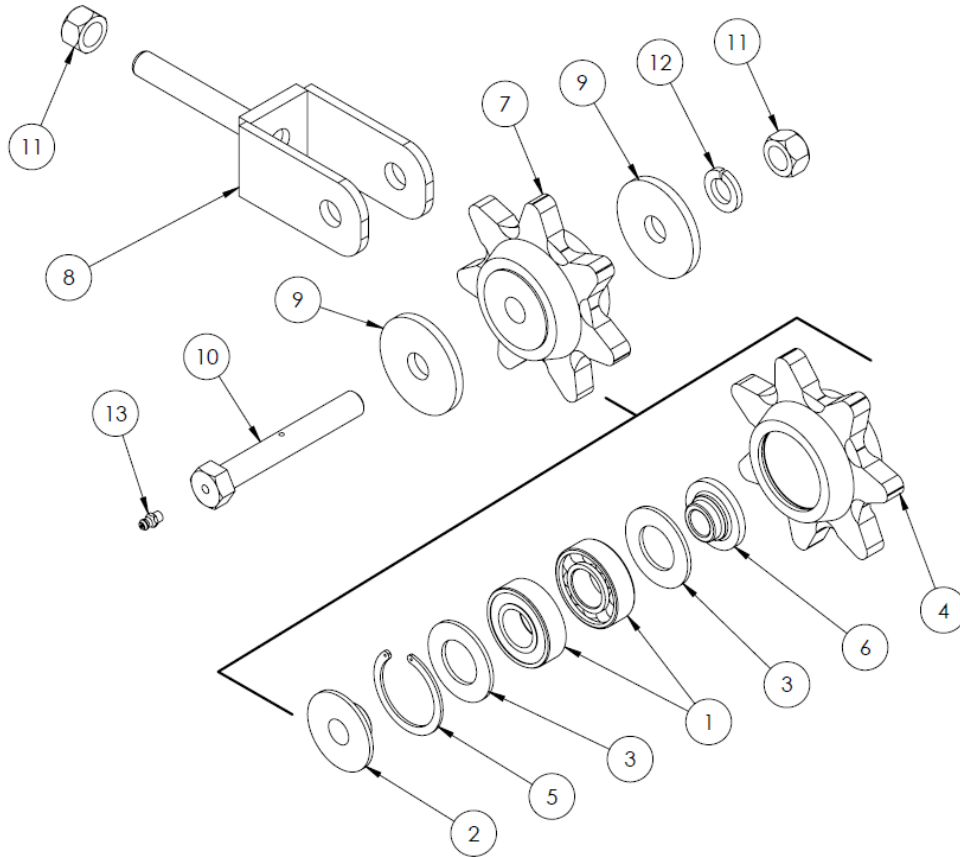

#	DESCRIPTION	PART #	QTY	
1	Idler Sprocket Bearing	23757	(2)	
2	Bushing, Snap Ring Side	27681	(1)	
3	Spacer	27680	(2)	
4	Idler Sprocket (Sprocket only)	27497	(1)	
5	Snap Ring	23755	(1)	
6	Bushing, Non-Snap Ring Side	27682	(1)	
7	Complete Idler Sprocket Assembly	Includes 1 - 6	27683	1
8	Chain Tensioner Bracket	31163	1	
9	Washer, 5/8" Heavy Flat	17972	2	
10	Grease-able 5/8" x 4-1/2" Bolt	23597	1	
11	Nut, 5/8"	10176	2	
12	Washer, 5/8" Lock	10276	1	
13	Grease Zerk	16364	1	

Lights and SMV Sign

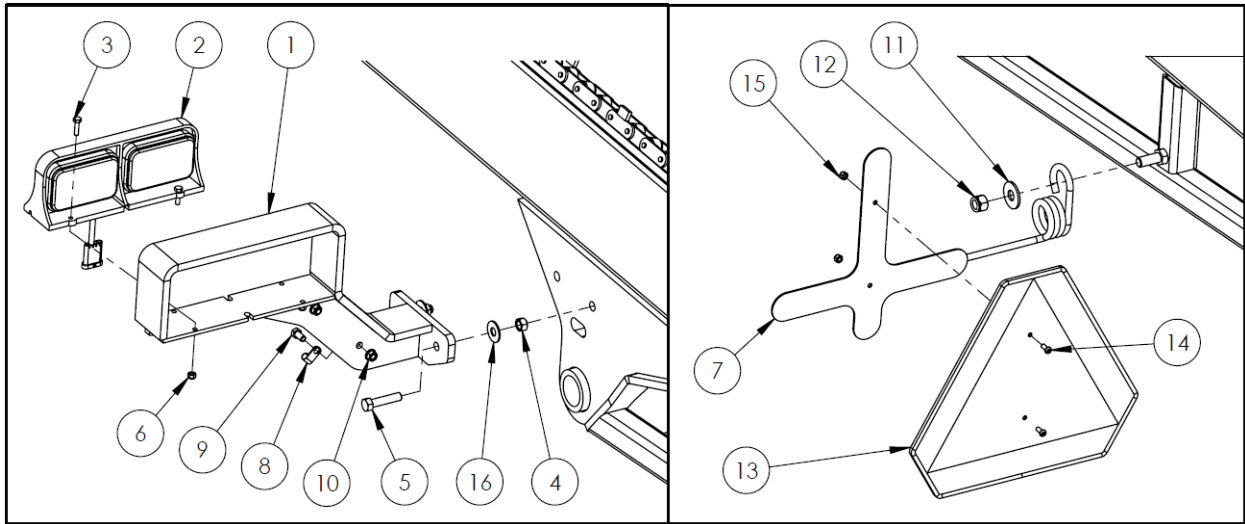

#	DESCRIPTION	PART #	QTY
1	Light Bracket	28689	2
2	Left Light (shown) Right Light	31087 31088	1 1
3	Bolt, 1/4 x 1"	11810	8
4	Nut, 1/2" Stover Lock	20154	4
5	Bolt, 1/2 x 2-1/4"	11820	4
6	Nut, 1/4" Nylon Lock	11664	8
7	SMV Sign Bracket	24656	1
8	Wire Clamp	13629	4
9	Bolt, 3/8 x 3/4"	11816	4
10	Nut, 3/8" Serrated Flange	10271	4
11	Bolt, 5/8" Heavy Flat	21390	1
12	Nut, 5/8" Nylon Lock	10364	1
13	SMV Sign	Comes as kit. Includes 14,15 22411	1
14	Bolt, 1/4 x 5/8" Screw Head	NSS	(2)
15	Nut, 1/4" Nylon Lock	NSS	(2)
16	Washer, 1/2" Flat	11668	2

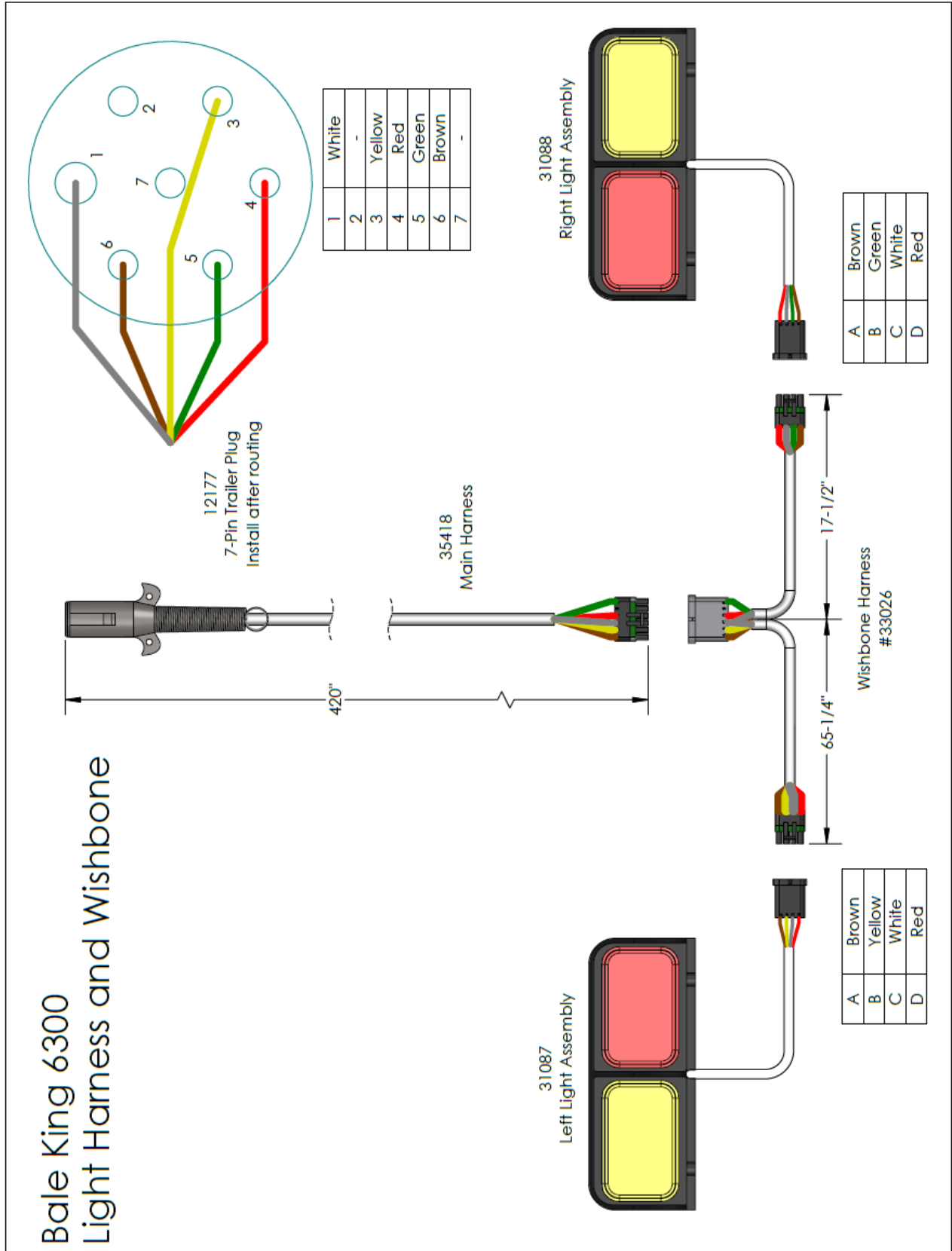

Decals



1



2



3



4

5

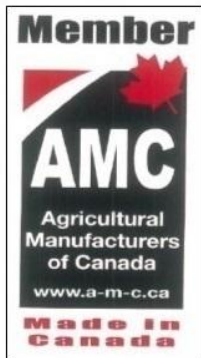

6



7



8



11



9



10



12



13



14

DECALS

#	DESCRIPTION	PART #	QTY
1	“BALE KING” “6300”	32804 35075	2 2
2	“DANGER”, PTO	12219	2
3	“DANGER”, Discharge	12230	4
4	“DANGER”, Stand Clear of Lift	12229	2
5	AMC Member	12239	1
6	FEMA Member	25347	1
7	Wheel Torque Reminder	28385	4
8	Deflector Safety Lock	22292	1
9	Red Reflector	28383	3
10	Amber Reflector	28384	9
11	Hoop Adjustment	32782	1
12	Total Ration **TR Only**	24862	1
13	Speed Limit Decal	33159	1
14	Hyd. Decal	33143	1

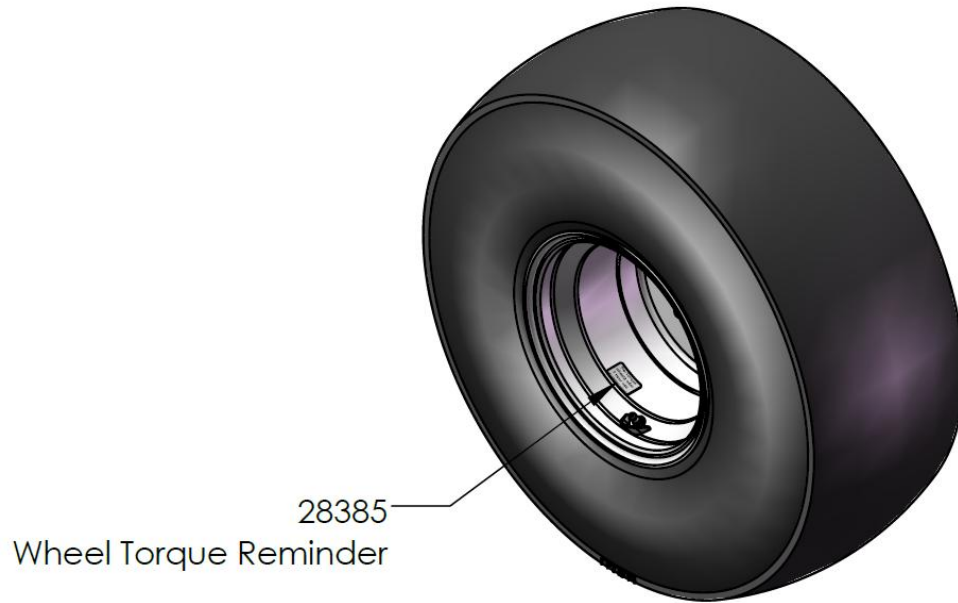

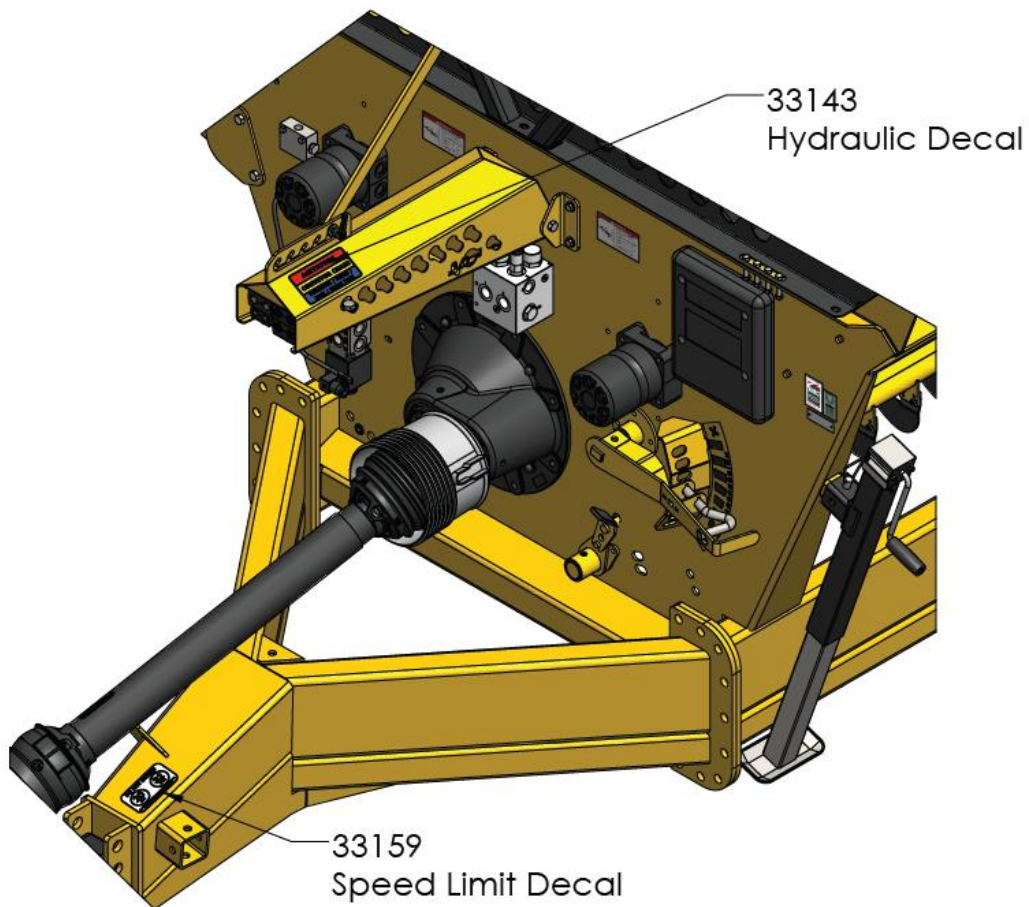
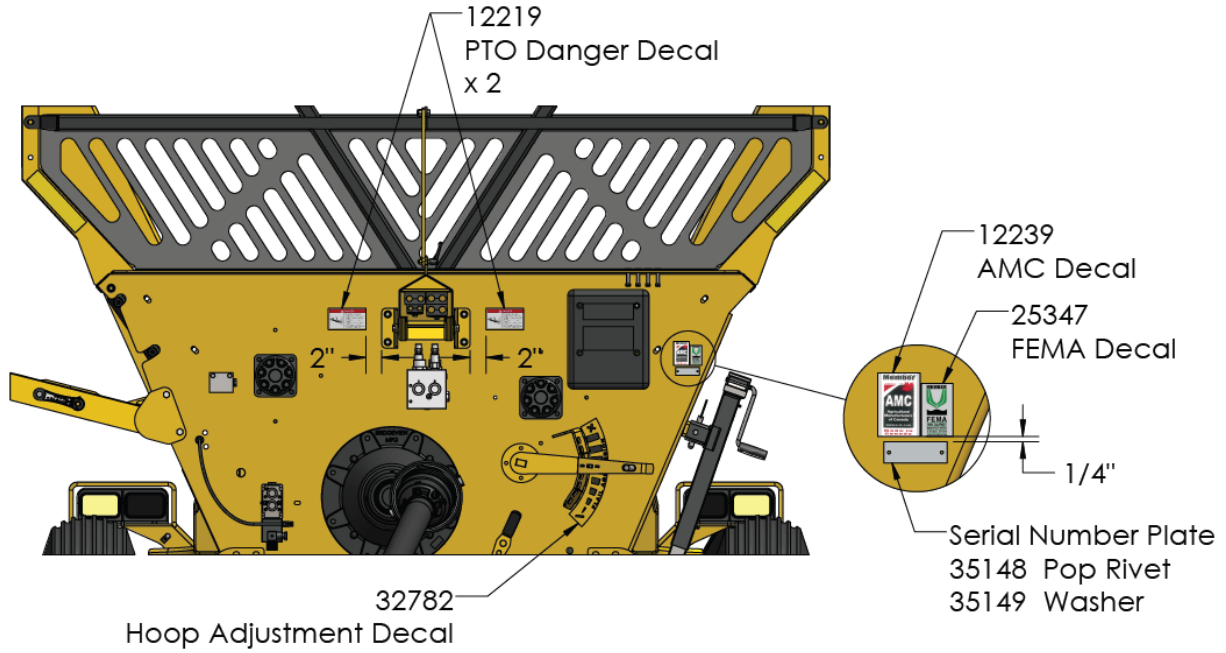

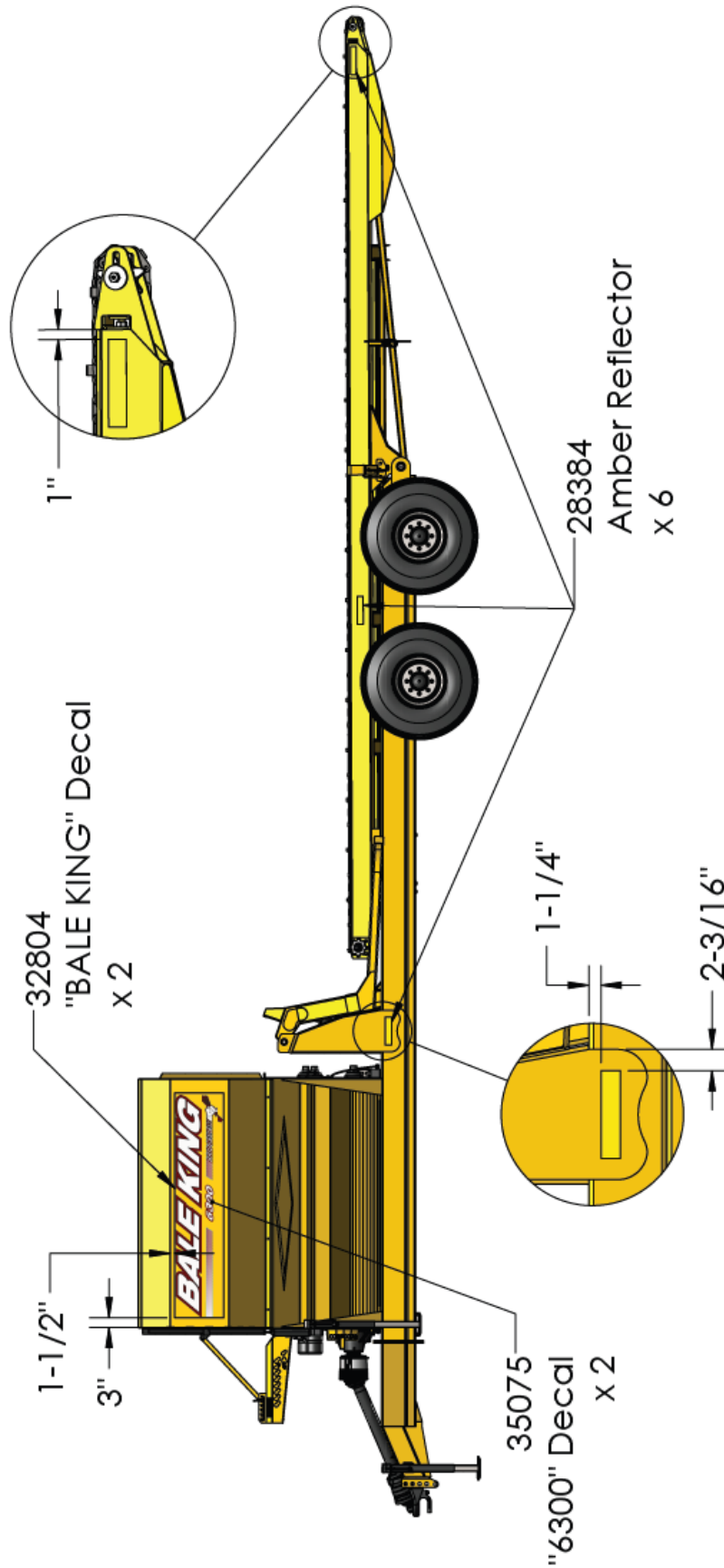

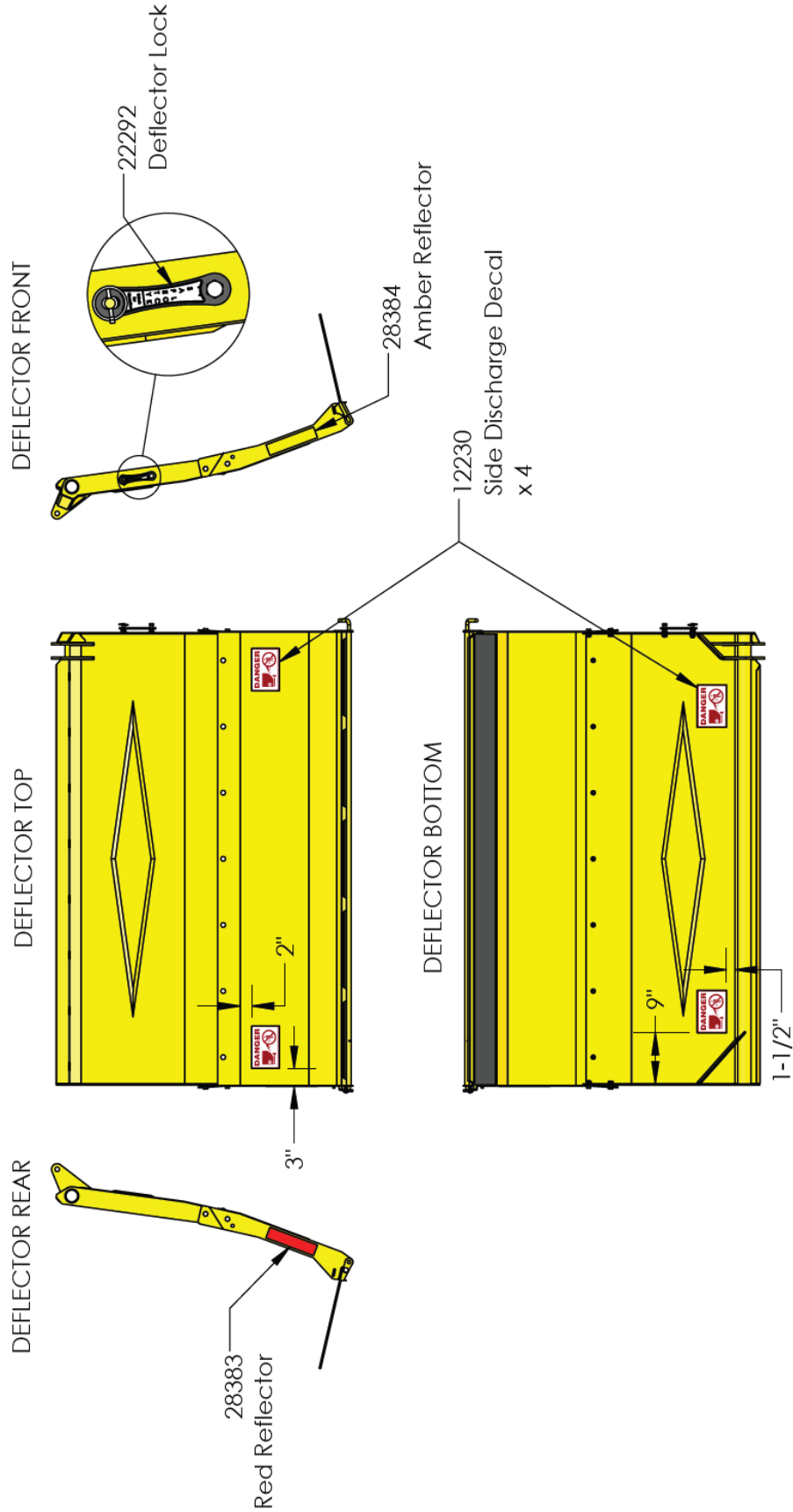

Total Ration Grain Tank Option

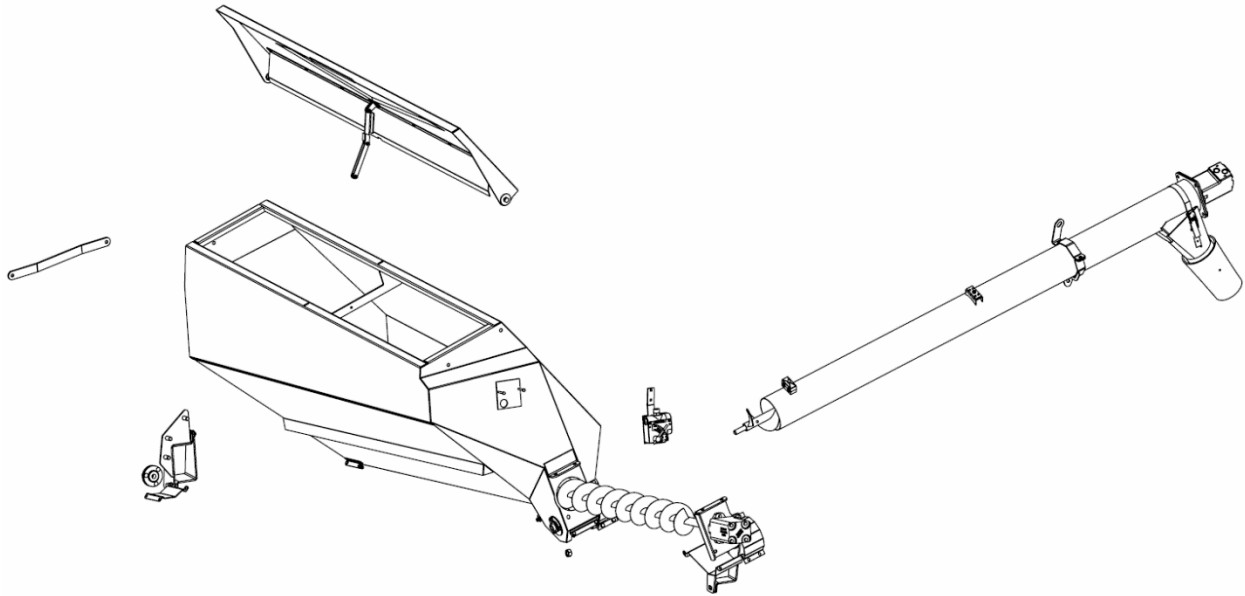

Item #	Description	
1	Tank Front	Page 63
2	Tank Rear	Page 65
3	Cross Auger	Page 67
4	Lid	Page 69

Total Ration Tank Front

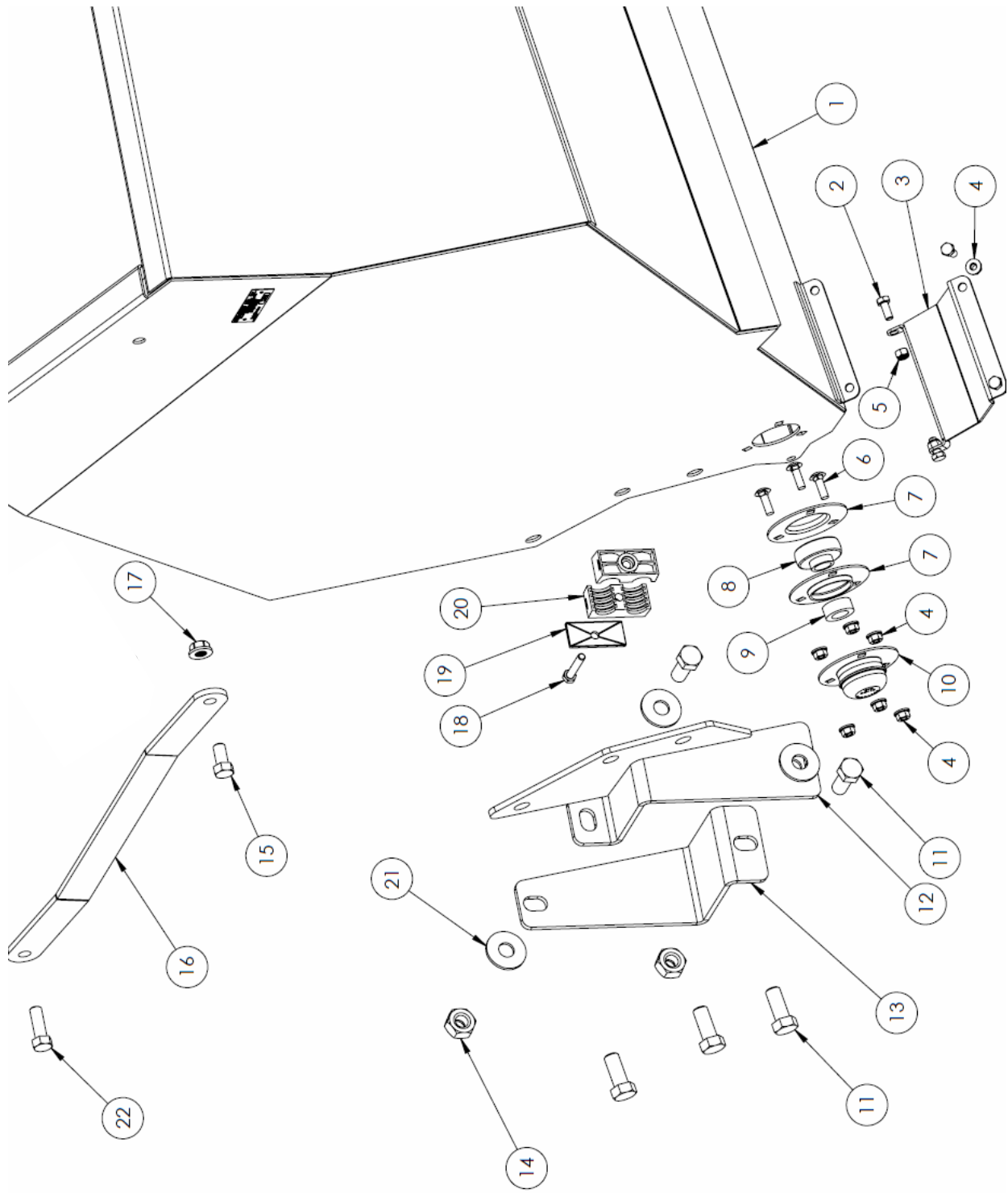

Total Ration Tank Front

#	DESCRIPTION	PART #	QTY
1	Total Ration Grain Tank	30199	1
2	Bolt, 5/16" x 3/4"	20903	4
3	Tank Cleanout Cover	30237	1
4	Nut, 5/16" Serrated Flange	11814	8
5	Nut, 5/16" Nylock	11815	2
6	Bolt, 5/16" x 1" Carriage	17884	3
7	Bearing, 3-Bolt Pressed Flange Housing	10368	2
8	Bearing, 3/4" Includes #9	10366	1
9	Bearing Lock Collar	10367	1
10	Bearing Cover	25117	1
11	Bolt, 5/8" x 1-1/2"	10173	5
12	6300 Front Mount Bracket	30252	1
13	6300 Front Mount Strap	30250	1
14	Nut, 5/8" Stover Lock	20150	2
15	Bolt, 1/2" x 1"	10824	2
16	Grain Tank Top Strap	30402	2
17	Nut, 1/2" Serrated Flange	10273	2
18	Bolt, 5/16" x 1.75"	21726	1
19	Hydraulic Hose Clamp Cap, Large	21715	1
20	Hydraulic Hose Clamp, 1/2"	21561	2
21	Washer, 5/8" Flat	13975	4
22	Bolt, 1/2" x 1-1/2"	10174	2

Total Ration Tank Rear

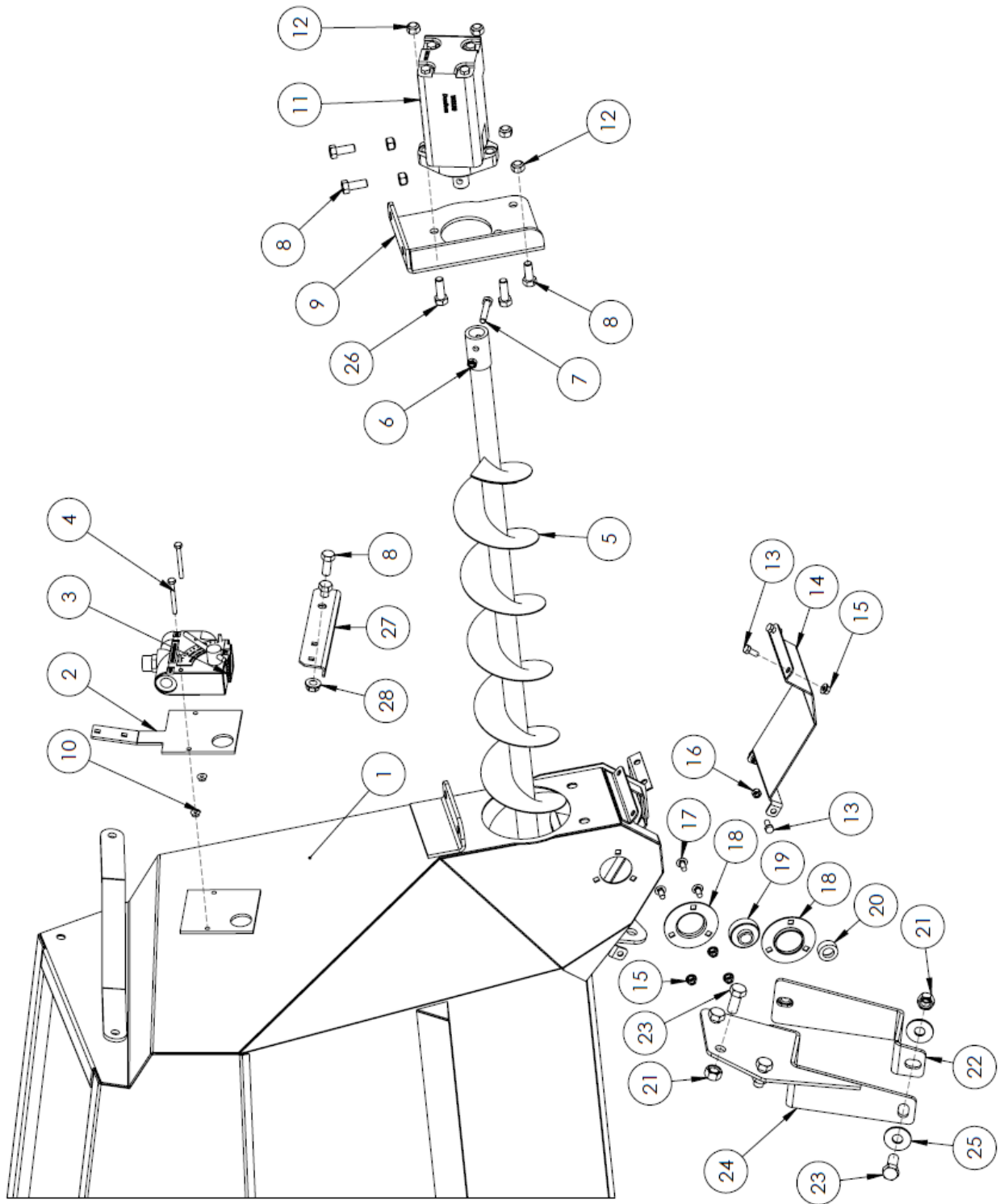

Total Ration Tank Rear

#	DESCRIPTION	PART #	QTY	
1	Total Ration Grain Tank	30199	1	
2	5300 SMV Sign Mount	5300TR Only	30389	-
3	Flow Control Valve	10455	1	
4	Bolt, 1/4 x 2-1/2"	20954	2	
5	Tank Auger	30175	1	
6	Nut, 3/8" Stover Lock	17586	1	
7	Bolt, 3/8" x 2"	10279	1	
8	Bolt, 1/2 x 1-1/4"	10240	4	
9	Tank Motor Mount	30233	1	
10	Nut, 1/4" Serrated Flange	11812	2	
11	Tank Motor, WS230	31172	1	
12	Nut, 1/2" Stover Lock	14393	6	
13	Bolt, 5/16 x 3/4"	20903	4	
14	Cross Auger Cleanout Cover	30235	1	
15	Nut, 5/16" Serrated Flange	11814	5	
16	Nut, 5/16" Nylon Lock	11815	2	
17	Bolt, 5/16 x 3/4" Carriage	11662	3	
18	Bearing, 3-Bolt Pressed Flange Housing	10368	2	
19	Bearing, 3/4"	Includes #20	10366	1
20	Bearing Lock Collar	10367	1	
21	Nut, 5/8" Stover Lock	20150	5	
22	6300 Rear Mount Strap	30255	1	
23	Bolt, 5/8" x 1-1/2"	10173	5	
24	6300 Rear Mount Bracket	30257	1	
25	Washer, 5/8" Flat	13975	4	
26	Bolt, 1/2 x 1-1/2"	10174	2	
27	SMV Sign Bracket	5300TR Only	33799	-
28	Nut, 1/2" Serrated Flange	10273	-	

Total Ration Cross Auger

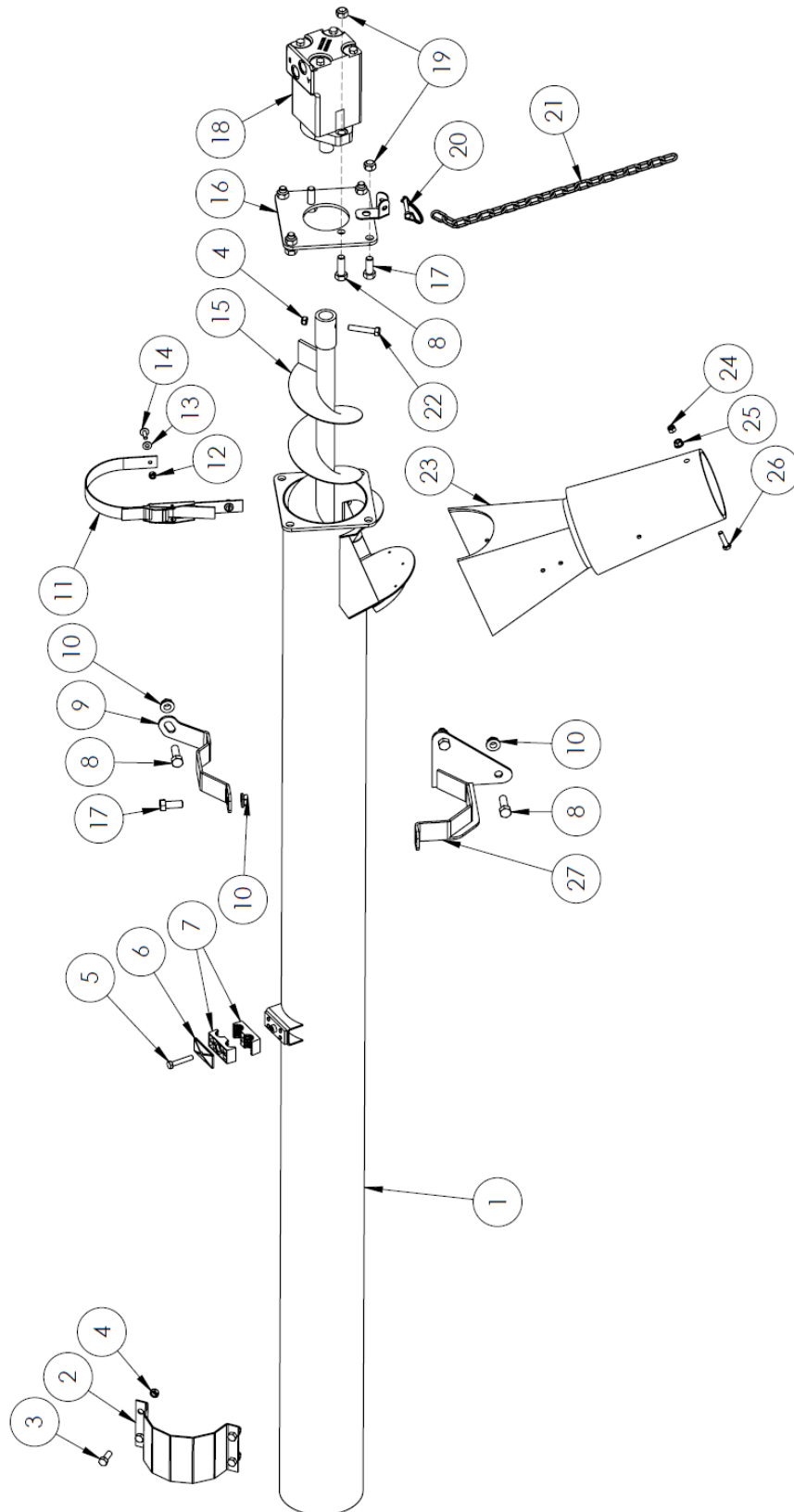

Total Ration Cross Auger

#	DESCRIPTION	PART #	QTY	
1	Cross Auger Pipe	30179	1	
2	Cross Auger Half Clamp	30401	1	
3	Bolt, 3/8" x 1"	13806	4	
4	Nut, 3/8" Stover Lock	17586	5	
5	Bolt, 5/16" x 1.75"	21726	1	
6	Hydraulic Hose Clamp Cap, Large	21715	1	
7	Hydraulic Hose Clamp, 1/2"	21561	2	
8	Bolt, 1/2" x 1-1/2"	10174	5	
9	Cross Auger Top Clamp	30187	1	
10	Nut, 1/2" Serrated Flange	10278	8	
11	Spout Strap	Includes both parts	25122	1
12	Nut, 1/4" Nylon Lock	11664	2	
13	Washer, 1/4" Flat	14448	2	
14	Bolt, 1/4" x 3/4" Truss Head	17638	2	
15	Cross Auger	30169	1	
16	Cross Auger Motor Mount	30194	1	
17	Bolt, 1/2" x 1-1/4"	10240	4	
18	Cross Auger Motor, WS080	30132	1	
19	Nut, 1/2" Stover Lock	14393	6	
20	Lock Pin, 1/4" x 1.25"	13951	1	
21	Chain, 3/16" x 20 links	25121	1	
22	Bolt, 3/8" x 2"	10279	1	
23	Auger Spout	10543	1	
24	Nut, 5/16" Nylon lock	11815	1	
25	Nut, 5/16" Serrated Flange	11814	1	
26	Bolt, 5/16" x 1-1/4"	24418	1	
27	Cross Auger Bottom Clamp	30189	1	

Total Ration Tank Lid

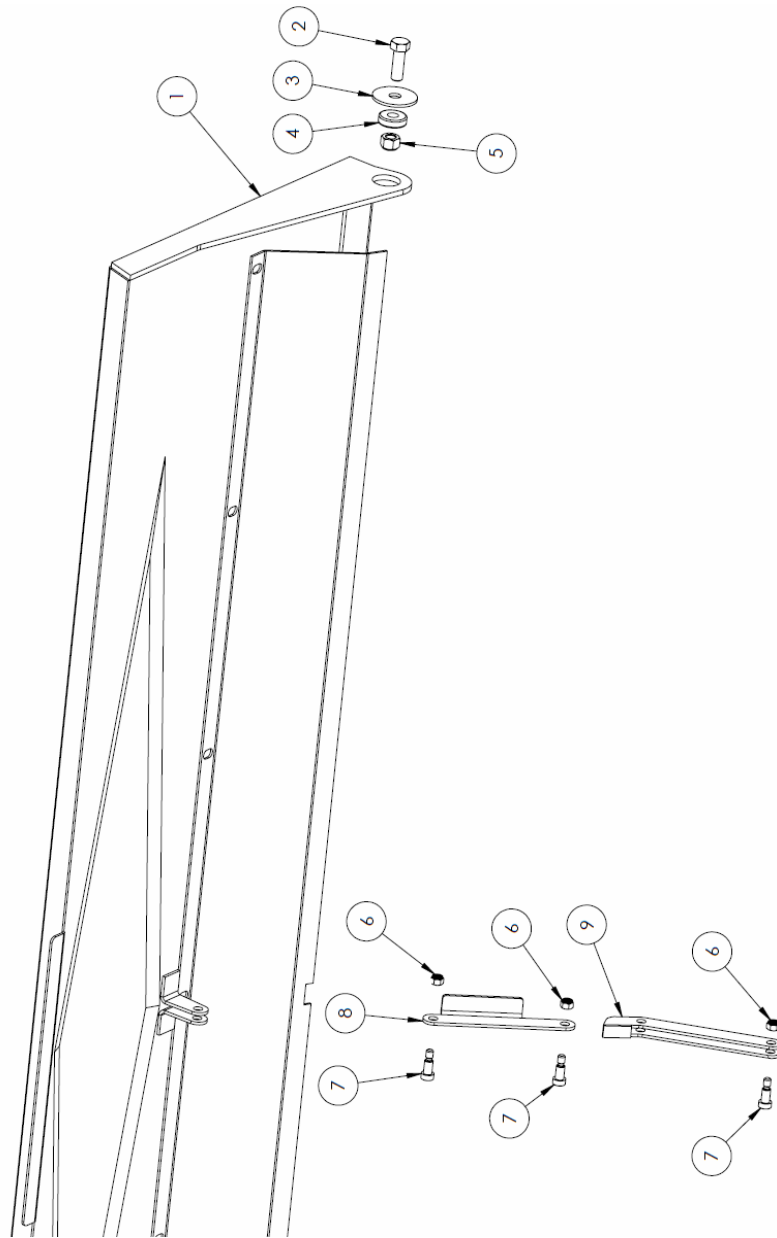

#	DESCRIPTION	PART #	QTY
1	Grain Tank Lid	30165	1
2	Bolt, 1/2" x 1-1/4"	10240	2
3	Washer, 1/2" Fender	10238	2
4	Bushing, 1/2" ID x 1.250" OD	10239	2
5	Nut, 1/2" Stover Lock	14393	2
6	Nut, 5/16" Nylon Lock	11815	3
7	Bolt, 3/8" x 5/8" Shoulder	30466	3
8	Lid Upper Support	30163	1
9	Lid Lower Support	30166	1

Fine Chop Option #36155

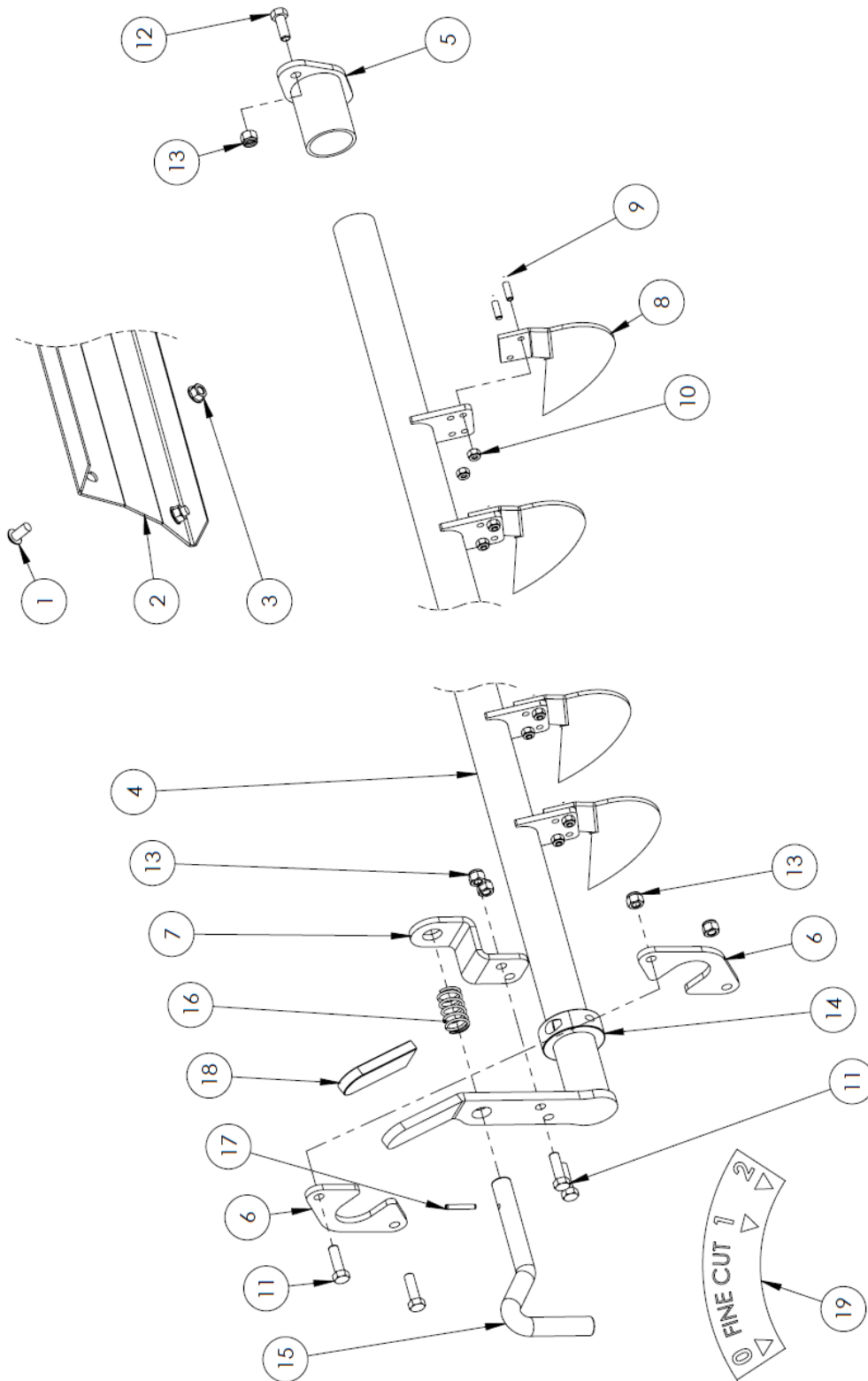

Fine Chop Option

#	DESCRIPTION	PART #	QTY
	Fine Chop Cover * IF NO FINE CHOP INSTALLED *		
1	Fin Bolt, 3/8" x 3/4"	10807	8
2	Fine Chop Cover Plate	36040	1
3	Nut, 3/8" Serrated Flange	11818	8

	Fine Chop Kit * Optional *	36155	1
4	Fine Chop Bar	36164	1
5	Fine Chop Mount Rear	22444	1
6	Fine Chop Front Mount	36163	2
7	Fine Chop Spring Mount	36161	1
8	Fine Chop Knife	10404	13
9	Bolt, 1/4" x 3/4"	11809	26
10	Nut, 1/4" Nylon Lock	11664	26
11	Bolt, 3/8 x 1-1/4"	10253	4
12	Bolt, 3/8" x 1"	13806	2
13	Nut, 3/8" Nylon Lock	10806	6
14	Split Collar	12792	1
15	S-Handle	22187	1
16	Compression Spring	34465	1
17	Roll Pin, 3/16 x 1-1/4"	10302	1
18	Rubber Handle	10297	1
19	Decal, Fine Chop	36031	1

Fine Chop Option #32117

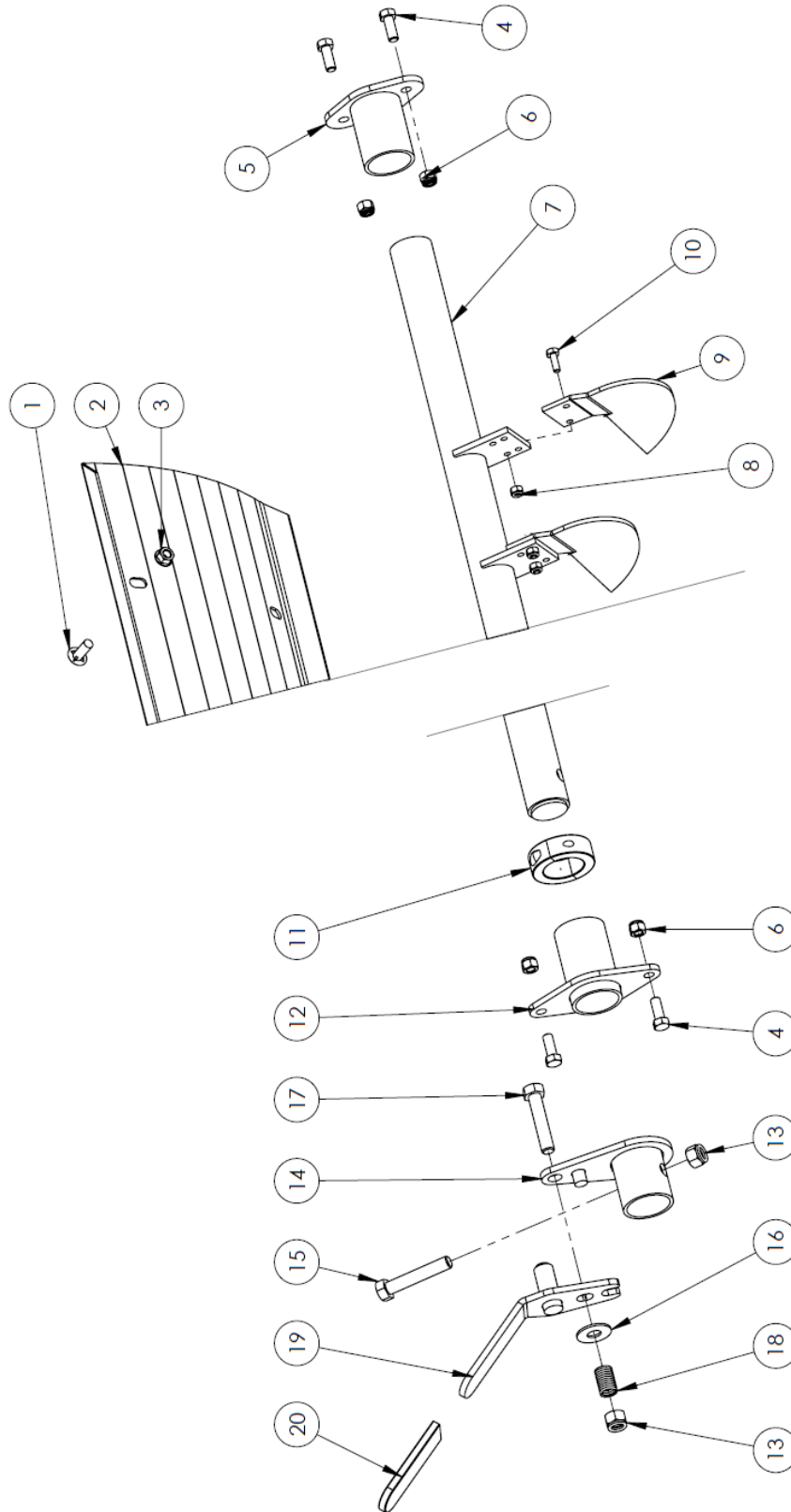

Fine Chop Option

#	DESCRIPTION	PART #	QTY
	Fine Chop Cover * IF NO FINE CHOP INSTALLED *		
1	Fin Bolt, 3/8" x 3/4"	10807	8
2	Fine Chop Cover Plate	22438	1
3	Nut, 3/8" Serrated Flange	10271	8
	Fine Chop Kit * Optional *	32117	1
4	Bolt, 3/8" x 1"	13806	4
5	Fine Chop Mount	22444	1
6	Nut, 3/8" Nylon Lock	10806	4
7	Fine Chop Bar	32118	1
8	Nut, 1/4" Nylon Lock	11664	26
9	Fine Chop Blade	10404	13
10	Bolt, 1/4" x 3/4"	11809	26
11	Split Collar	12792	1
12	Fine Chop Front Mount	32122	1
13	Nut, 1/2" Nylon Lock	10241	2
14	Fine Chop Pivot	32127	1
15	Bolt, 1/2" x 2-3/4"	12378	1
16	Flat Washer, 1/2"	11668	1
17	Bolt, 1/2" x 2-1/2"	10804	1
18	Compression Spring	21713	1
19	Fine Chop Handle	32132	1
20	Rubber Cover	10297	1

Twine Cutter Option

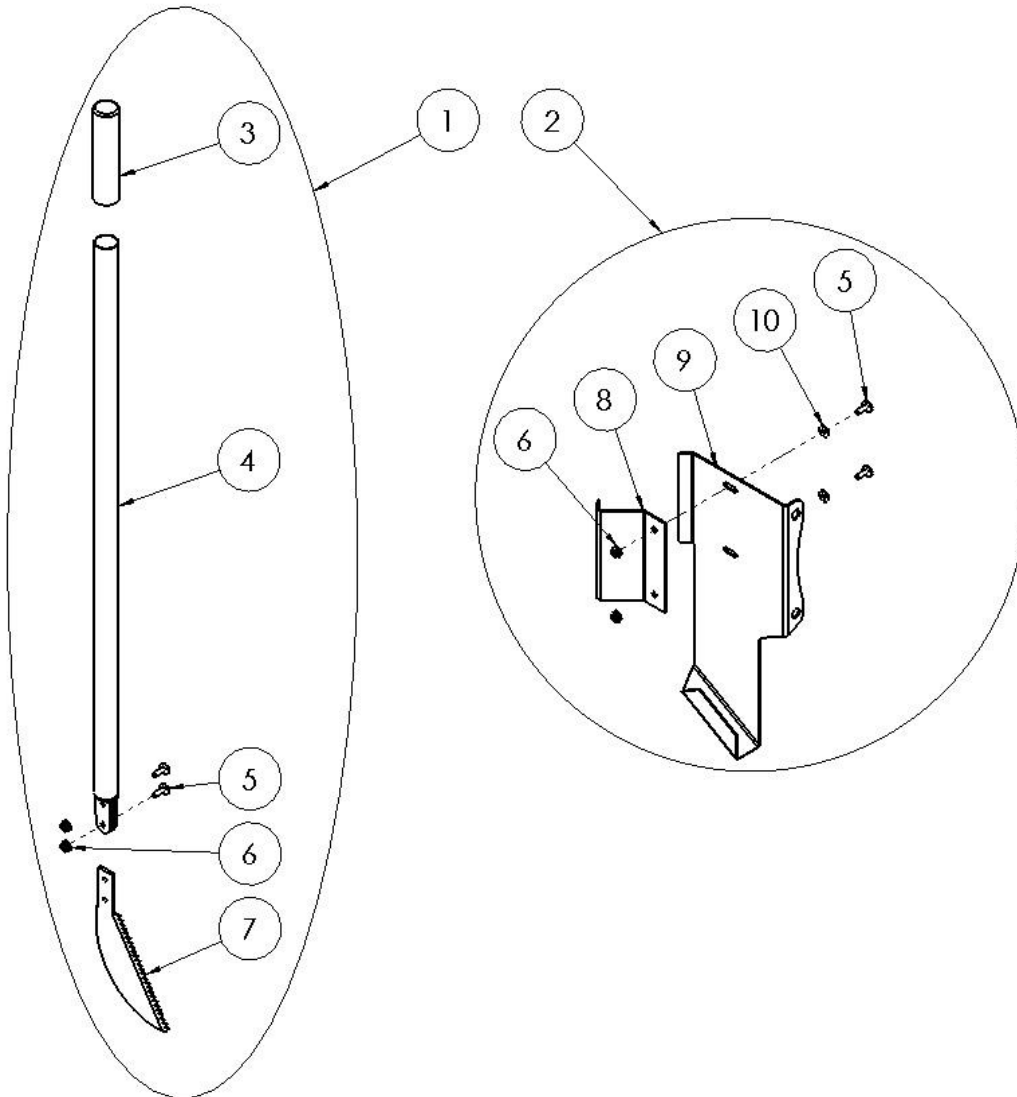

#	DESCRIPTION	PART #	QTY
	Twine Cutter Kit	17686	1
1	Twine Cutter Handle Kit	-	1
2	Twine Cutter Holder Kit	21549	1
3	Rubber Handle Cap	17587	1
4	Twine Cutter Handle	20862	1
5	Bolt, 1/4" x 3/4" Truss Head	17638	4
6	Nut, 1/4" Serrated Flange	11812	4
7	Twine Cutter Blade	17438	1
8	Twine Cutter Holder Inside Bracket	17690	1
9	Twine Cutter Holder Outside Bracket	17691	1
10	Flat Washer, 1/4"	11666	2

Diverter Control Box

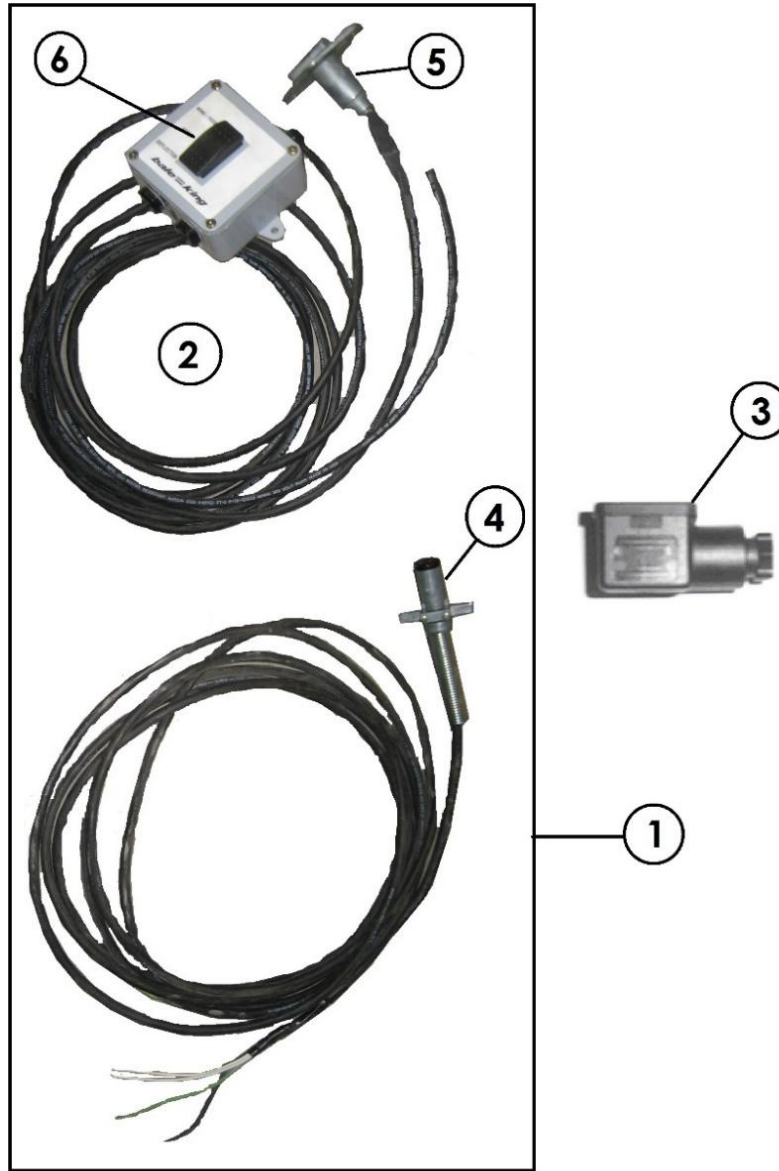

#	DESCRIPTION	PART #	QTY
1	Complete Control Box with Harness (Standard) Complete Control Box with Harness (4 Function) #	24466 33134	1
2	Complete Control Box with Cab to Hitch Harness (6300 Series)	-	1
3	Square Plug for Diverter Valve	13657	*
4	4-pin Trailer Plug	24691	1
5	4-pin Tractor Plug	24690	1
6	3-way Switch	13561	1

* NOTE: 1 plug is needed for each diverter valve.
NOTE: Only used on 6300TR with 3 diverter valves

Diverter Machine Side Harness

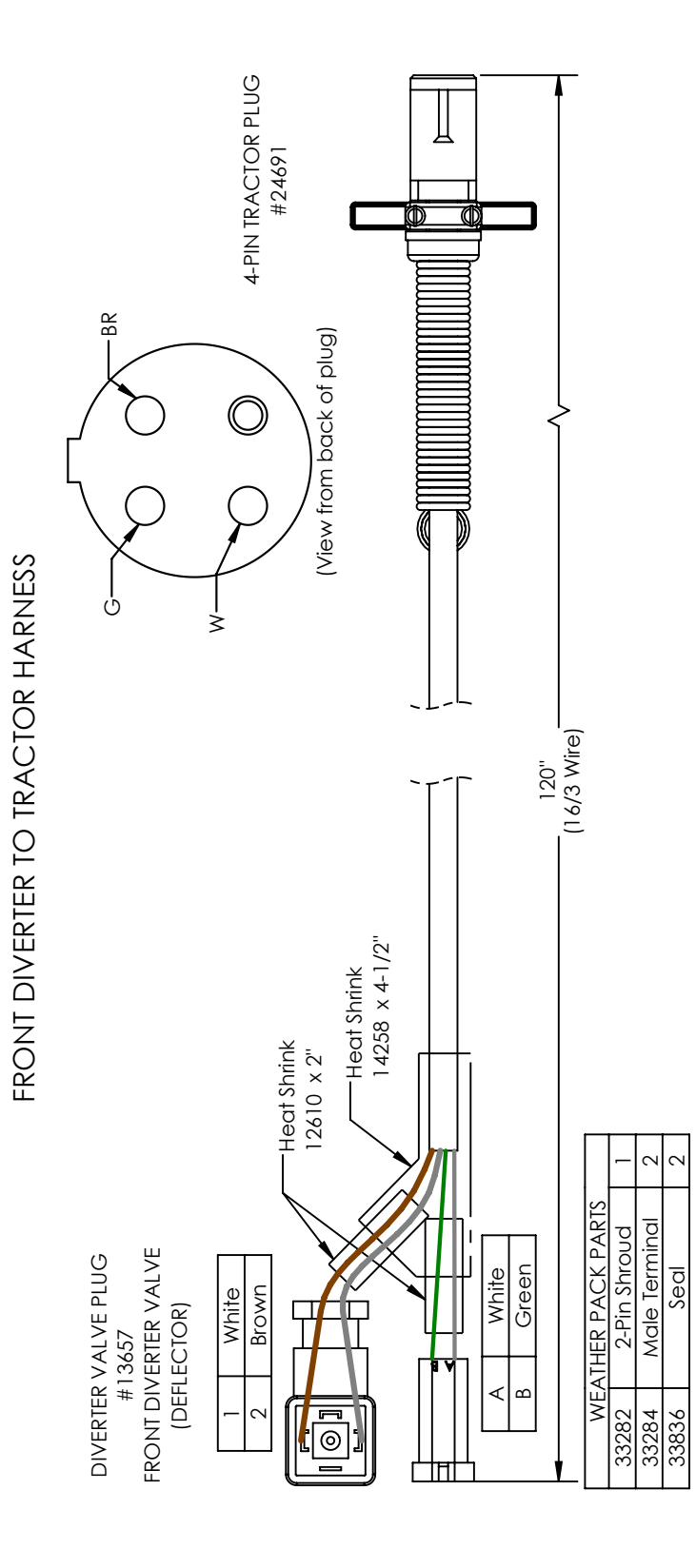
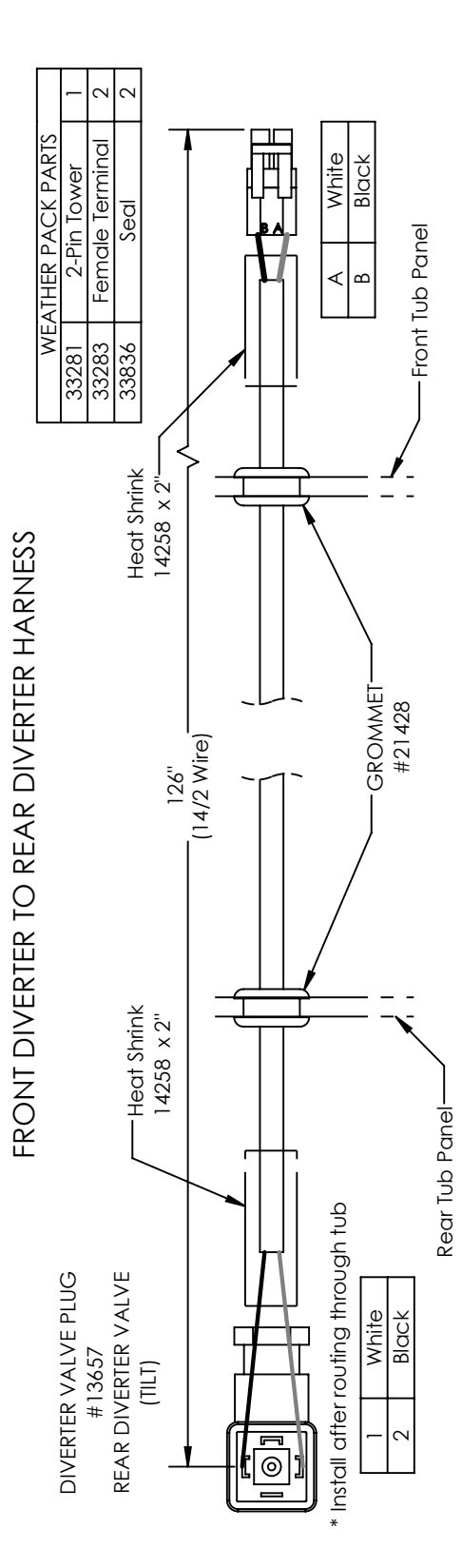

Diverter Control Box #24466

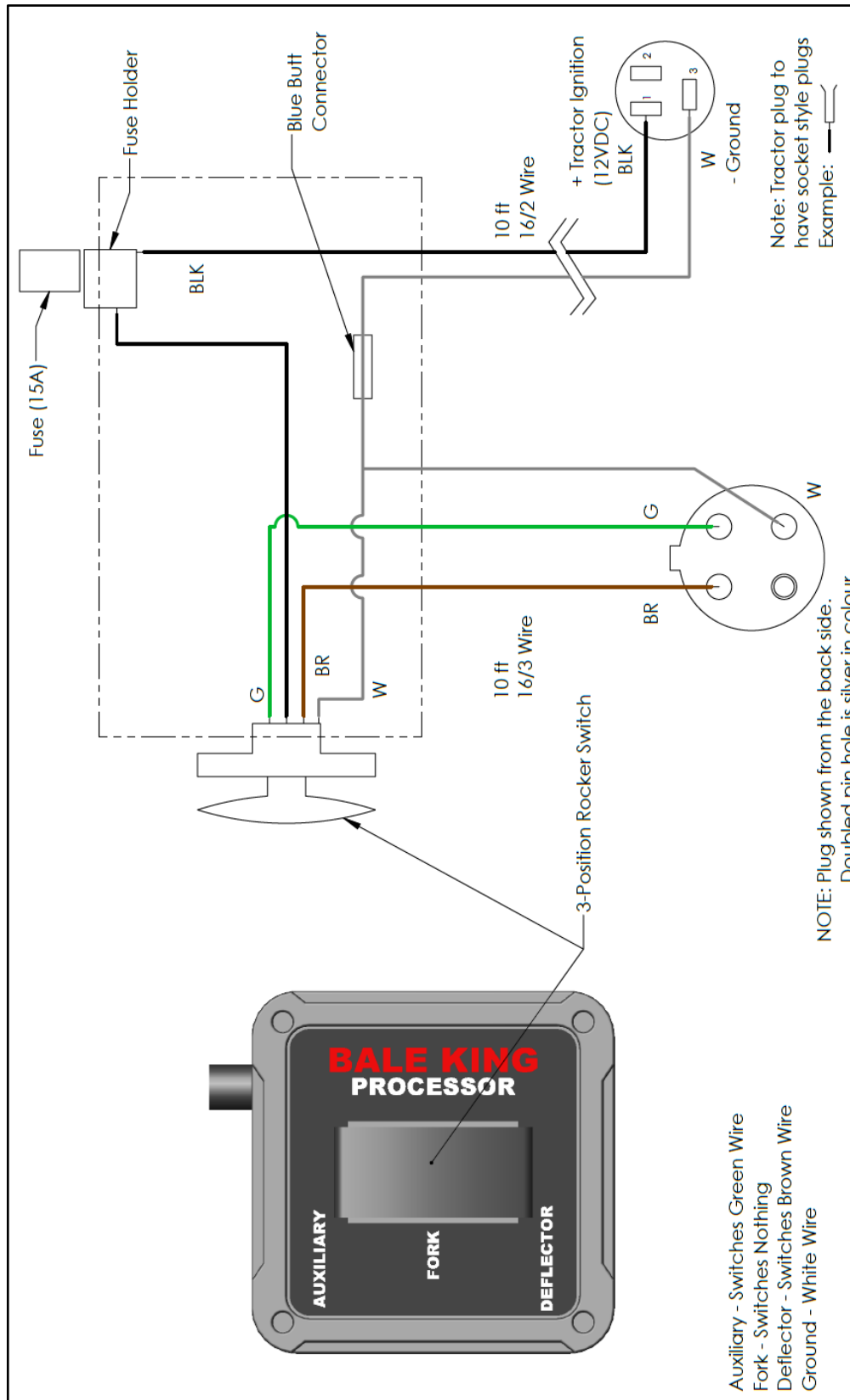

Diverter Machine Side Harness (TR Option)

FRONT DIVERTER TO REAR DIVERTER HARNESS

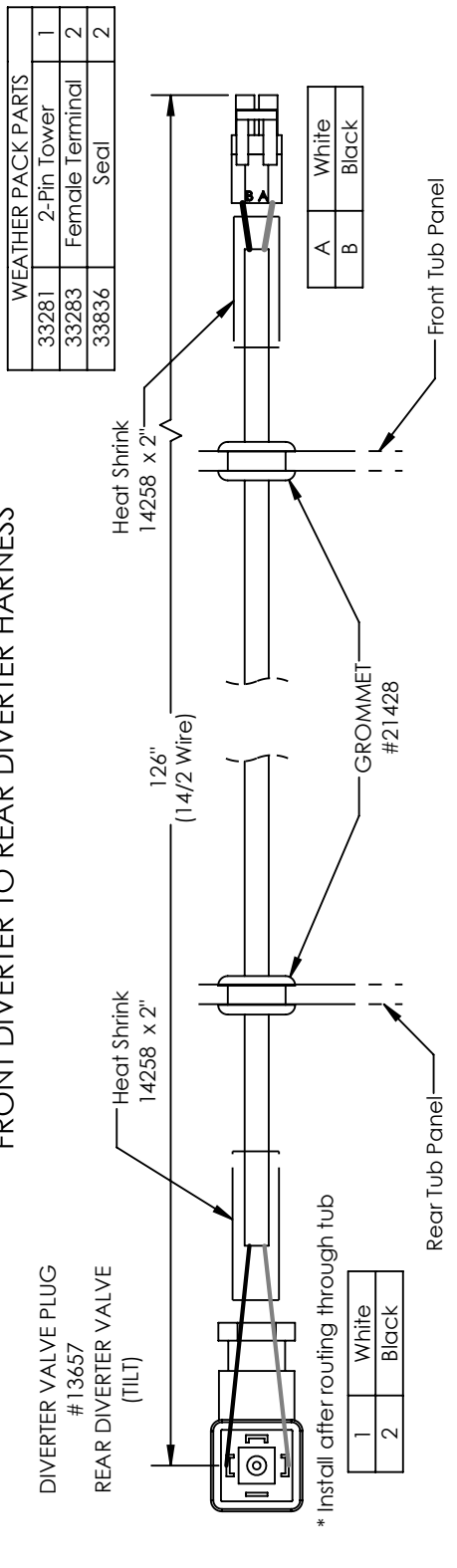

FRONT DIVERTER TO TRACTOR HARNESS

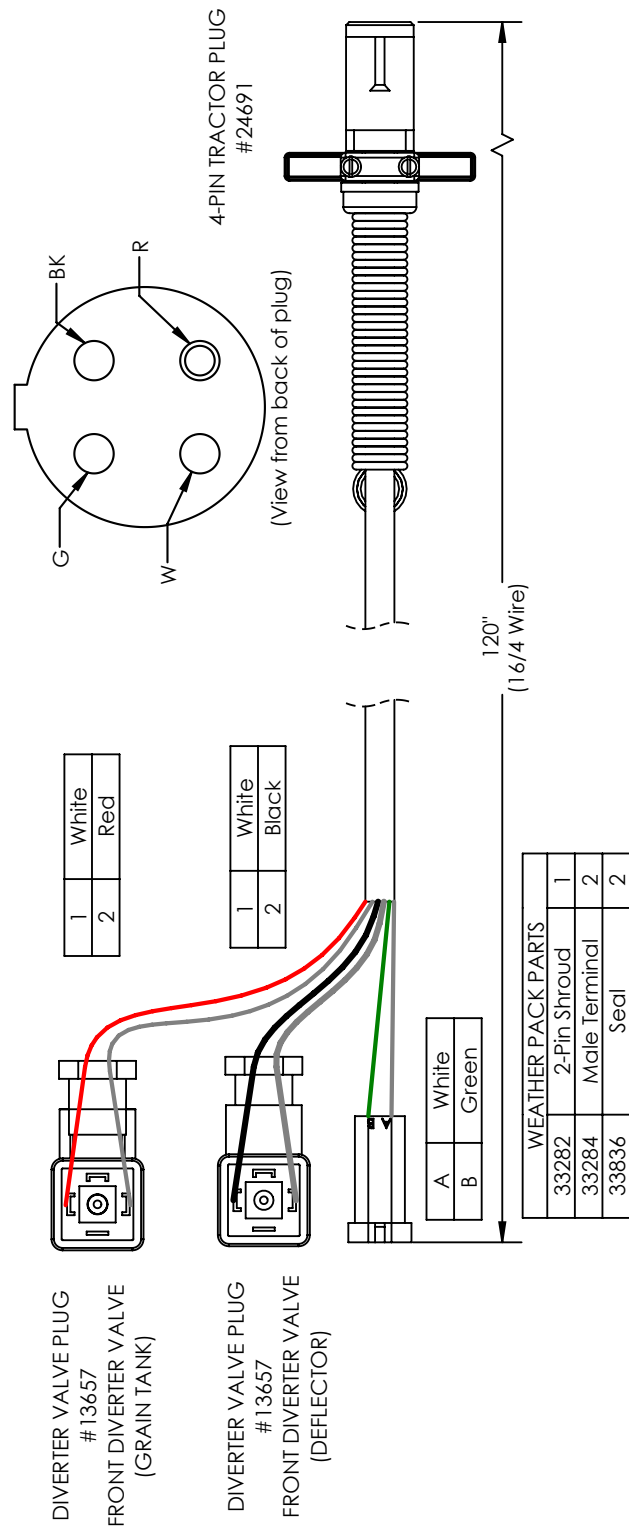

Diverter Control Box #33134 (4 Function with Additional Push Button Switch)

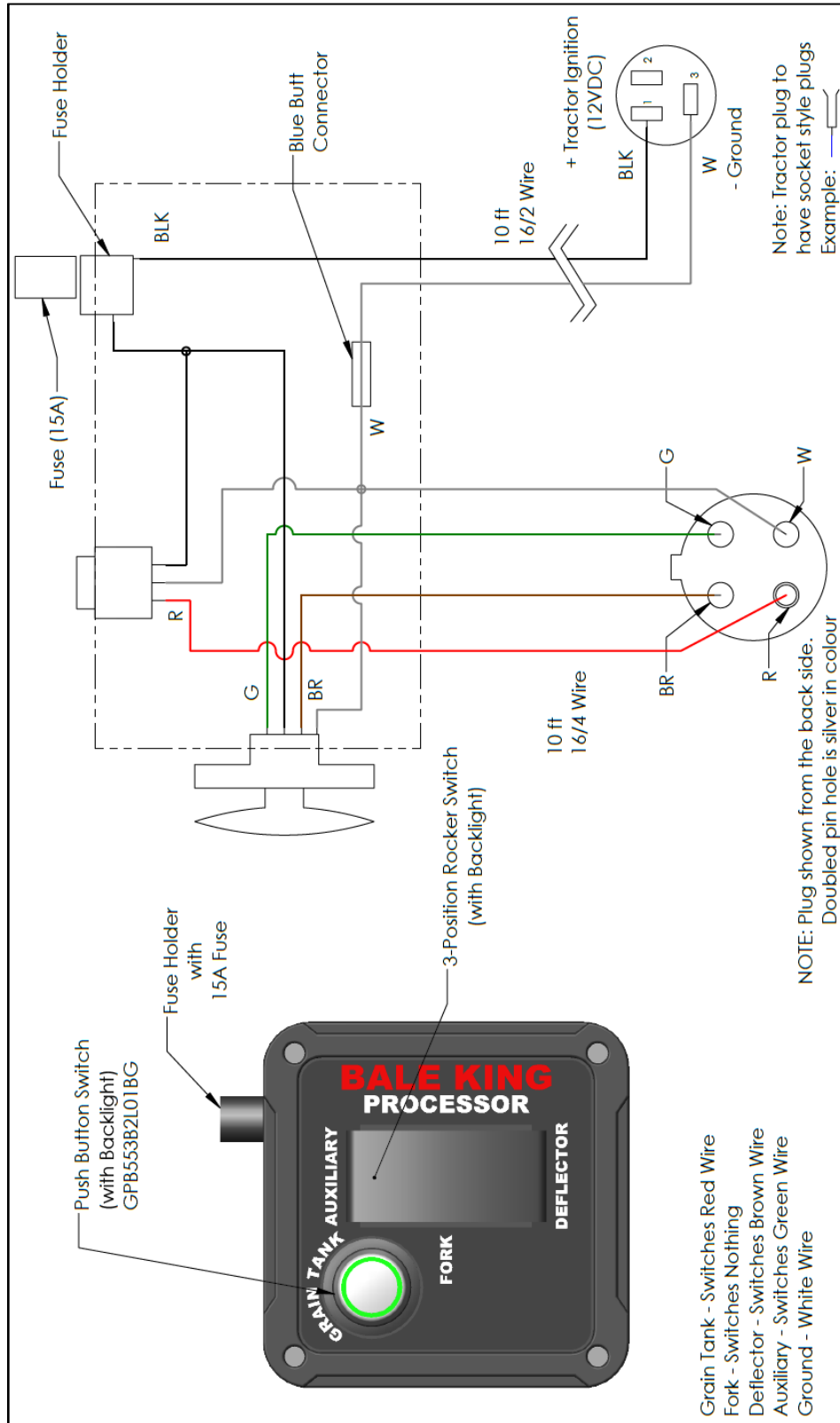

Hydraulic Schematics

HYDRAULIC COMPONENTS

#	DESCRIPTION	PART #
AA	Hydraulic Motor * Seal Kit	Rollers
		25872 25891
BB	Hydraulic Motor * Seal Kit	Left Chain
		28702 25891
CC	Hydraulic Motor * Seal Kit	Right Chain
		28703 25891
DD	Hydraulic Motor – WS230	TR Tank Auger
EE	Hydraulic Motor – WS080	TR Cross Auger
FF	Hydraulic Cylinder - 3 x 18 x 1.5” * Seal Kit * Stopper Kit	Rear Forks
		21717 20807 21860
GG	Hydraulic Cylinder – 4 x 14 x 2” *Seal Kit	Bed Tilt
HH	Hydraulic Cylinder - 1.5 x 6 x 1” * Seal Kit	Deflector
		21711 23738
II	Flow Divider Valve	Roller Motors
JJ	Flow Divider Valve	Chain Motors
KK	Pilot-operated Check Valve	Deflector
LL	Diverter Valve * Nut & O-Ring * Magnet * Stack Kit	Fork, Tilt, Deflector
		11743 17977 11789
MM	Flow Control Valve	TR Only
NN	Check Valve, 8MJ-8FB	TR Only
OO	Pioneer Tip, 8FB	
PP	Hose Marker, Long Red	Rollers
QQ	Hose Marker, Short Red	
RR	Hose Marker, Long Blue	Fork, Tilt, Deflector
SS	Hose Marker, Short Blue	
TT	Hose Marker, Long Yellow	Chain
UU	Hose Marker, Short Yellow	

NOTE: Quantities vary depending on machine set-up. Order as required.

HYDRAULIC FITTINGS

#	DESCRIPTION	PART #
A	Adaptor, 12MB-8MJ90	22174
B	Adaptor, 10MB-8MJ90	12169
C	Adaptor, 10MB-8MJ45	23844
D	Adaptor, 10MB-8MJ	10161
E	Adaptor, 10MB-6MJ45	22722
F	Adaptor, 10MB-6MJ	11739
G	Adaptor, 8MB-8MJ	10561
H	Adaptor, 8MB-8MJ90	12169
J	Adaptor, 8MB-6MJ	11740
K	Adaptor, 8MB-6MJ90	10200
L	Adaptor, 8MJBH	28774
M	Adaptor, 8MJBH90	10531
N	Adaptor, 8MJBHL-8MJT	21581
P	Adaptor, 8MBR-8MJT	22159
Q	Adaptor, 8FJXR-8MJT	11768
R	Adaptor, 6MB-6MJ	10162
S	Adaptor, 6MB-6MJ90	10201
T	Adaptor, 6MJ-6FJX90	12162
U	Adaptor, 6MJBH90	10187
V	Adaptor, 6MBR-6MJT	23726
W	Adaptor, 6MB-6MJ Orifice (1/32")	17436

NOTE: Quantities vary depending on machine set-up. Order as required.

HYDRAULIC HOSES

#	DIA.	LENGTH	ENDS
1	1/2"	260" OAL	8FJX - 8FJX
2	1/2"	132" OAL	8FJX - 8MB
3	1/2"	122" OAL	8FJX - 8MB
4	1/2"	122" OAL	8FJX - 8FJX90
5	1/2"	102" OAL	8FJX90 - 8FJX
6	1/2"	98" OAL	8MB - 8FJX
7	1/2"	81" OAL	8FJX - 8FJX
8	1/2"	70" OAL	8FJX - 8FJX
9	1/2"	48" OAL	8FJX - 8FJX
10	1/2"	44.5" OAL	8FJX - 8FXJ90
11	1/2"	42" OAL	8FJX - 8FJX45
12	1/2"	40" OAL	8FJX - 8FJX45
13	1/2"	33" OAL	8FJX - 8FJX45
14	1/2"	33" OAL	8FJX - 8MB
15	1/2"	24" OAL	8FJX - 8FJX90
16	3/8"	179" OAL	6FJX - 6FJX
17	3/8"	173" OAL	6FJX - 6FJX90
18	3/8"	122" OAL	6FJX - 8MB
19	3/8"	79.5" OAL	6FJX - 6FJX
20	3/8"	78" OAL	6FJX - 8FJX90
21	3/8"	53" OAL	6FJX - 8FJX
22	3/8"	35" OAL	6FJX - 8FJX
23	3/8"	33.5" OAL	6FJX - 8FJX
24	3/8"	17.25" OAL	6FJX - 6FJX90
25	3/8"	16.25" OAL	6FJX - 6FJX
26	3/8"	13.5" OAL	6FJX - 6FJX
27	3/8"	11.25" OAL	6FJX - 6FJX90
28	3/8"	8.75" OAL	6FJX - 6FJX
29	3/8"	8.5" OAL	6FJX - 6FJX
30	1/4"	20.25" OAL	6FJX90 - 6FJX
31	1/4"	16.25" OAL	6FJX - 6FJX90L
32	1/4"	13.5" OAL	6FJX - 6FJX
33	1/4"	12.25" OAL	6FJX - 6FJX90L

NOTE: Hoses are not available for sale. Use the information above to have replacement hoses made up locally.
All hoses should be double braid, with crimps rated for at least 3500 psi.

FRONT PANEL – ROLLERS

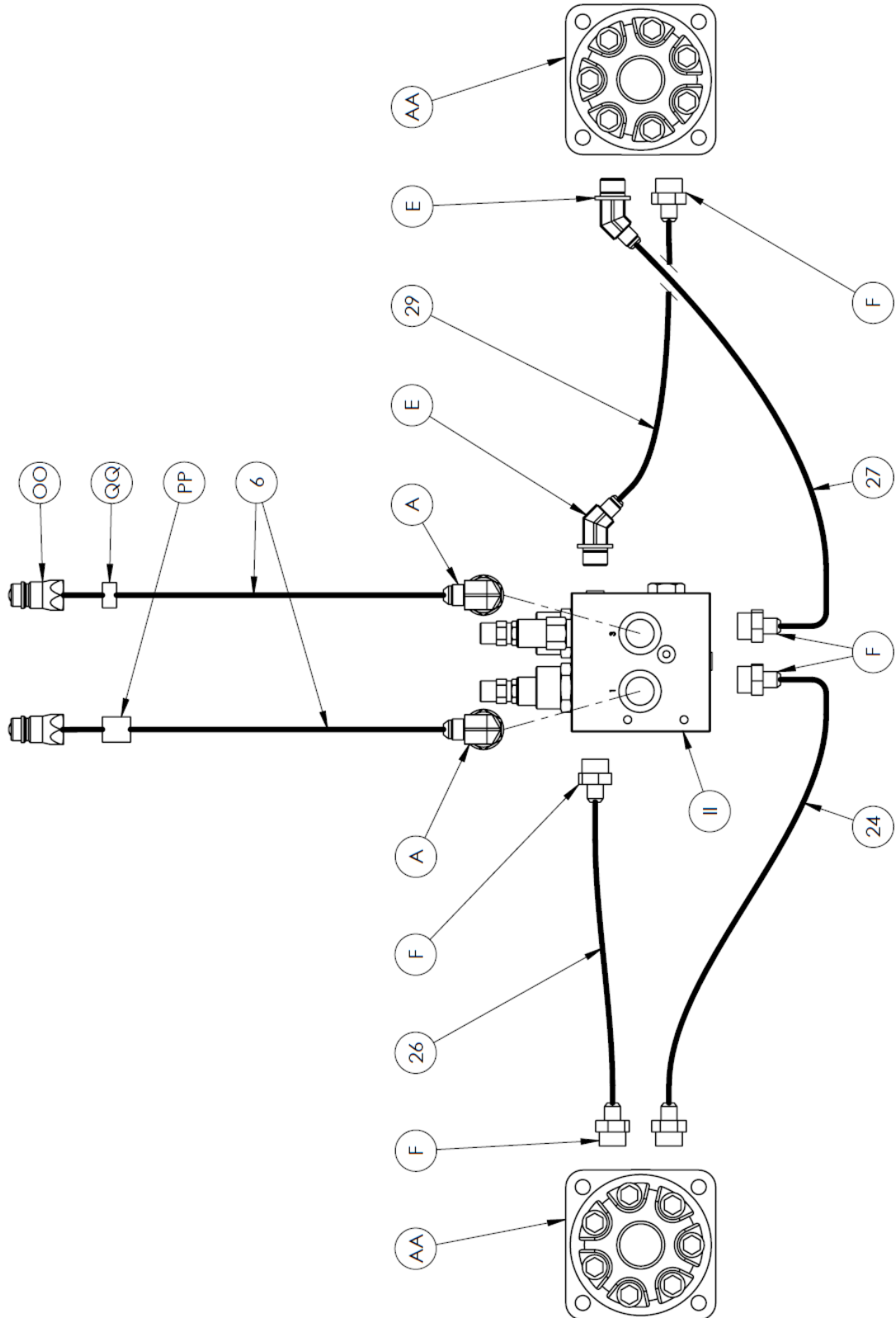

FRONT PANEL - DEFLECTOR

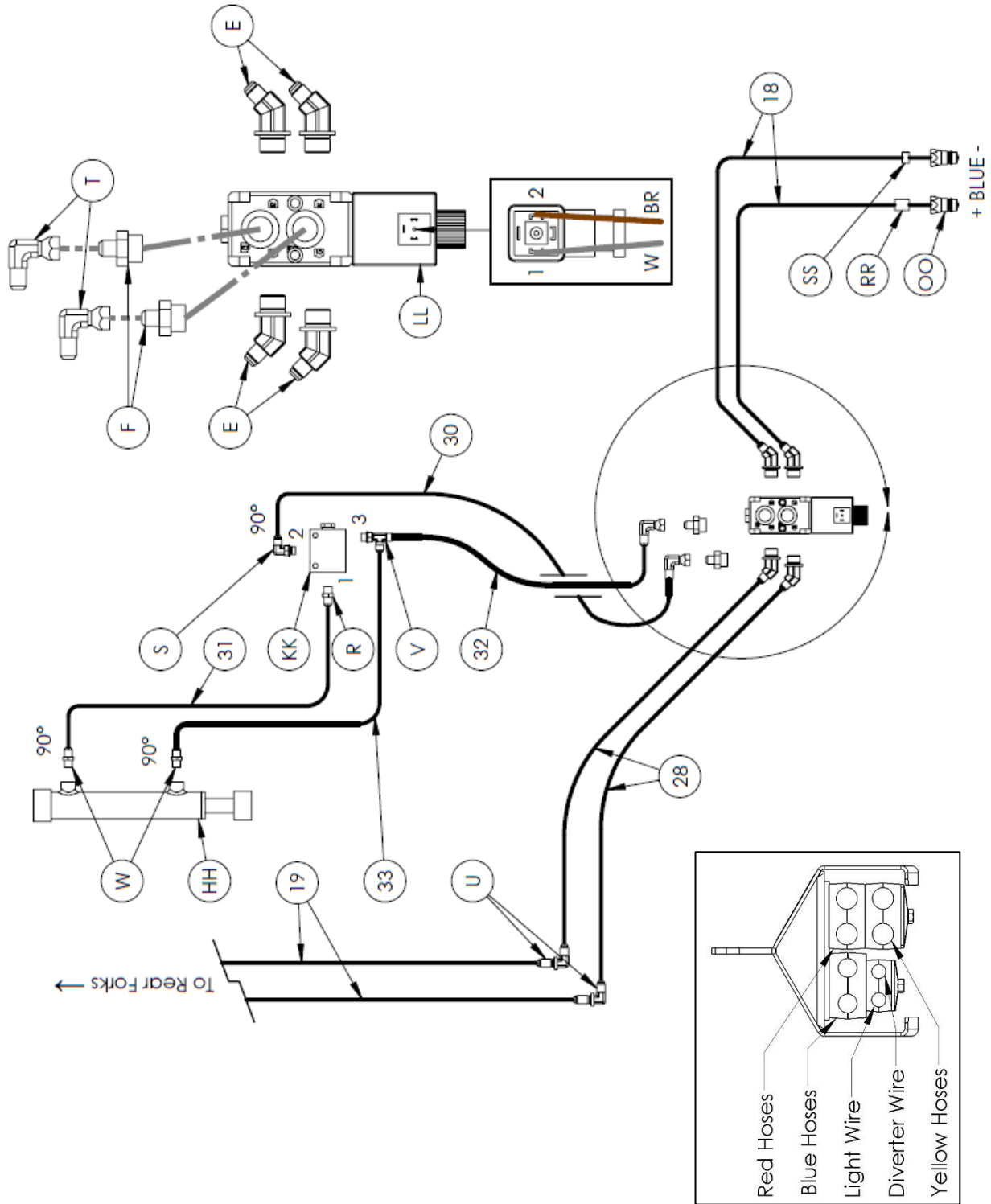

FRONT PANEL – 6300TR

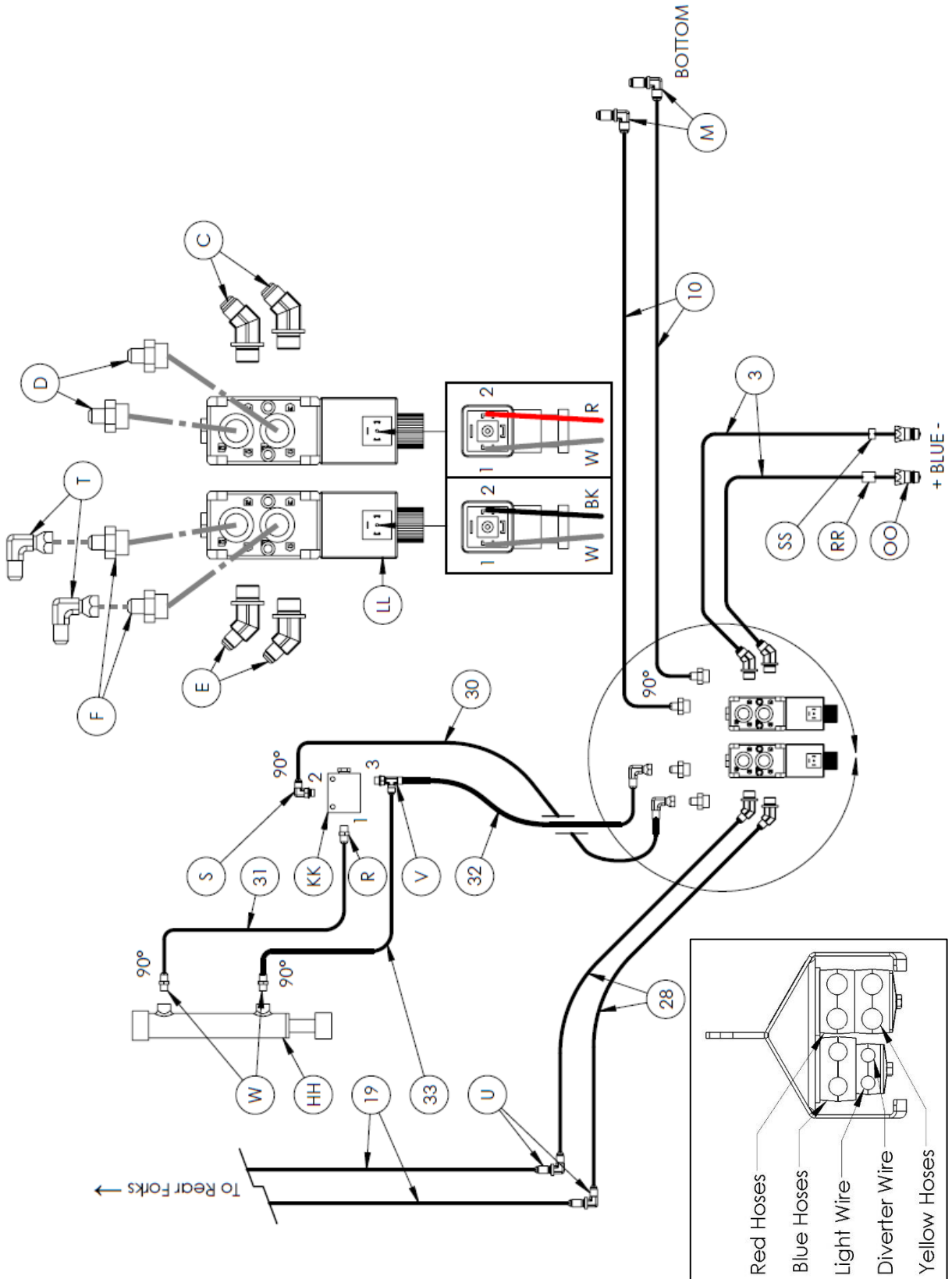

REAR FORK & TILT

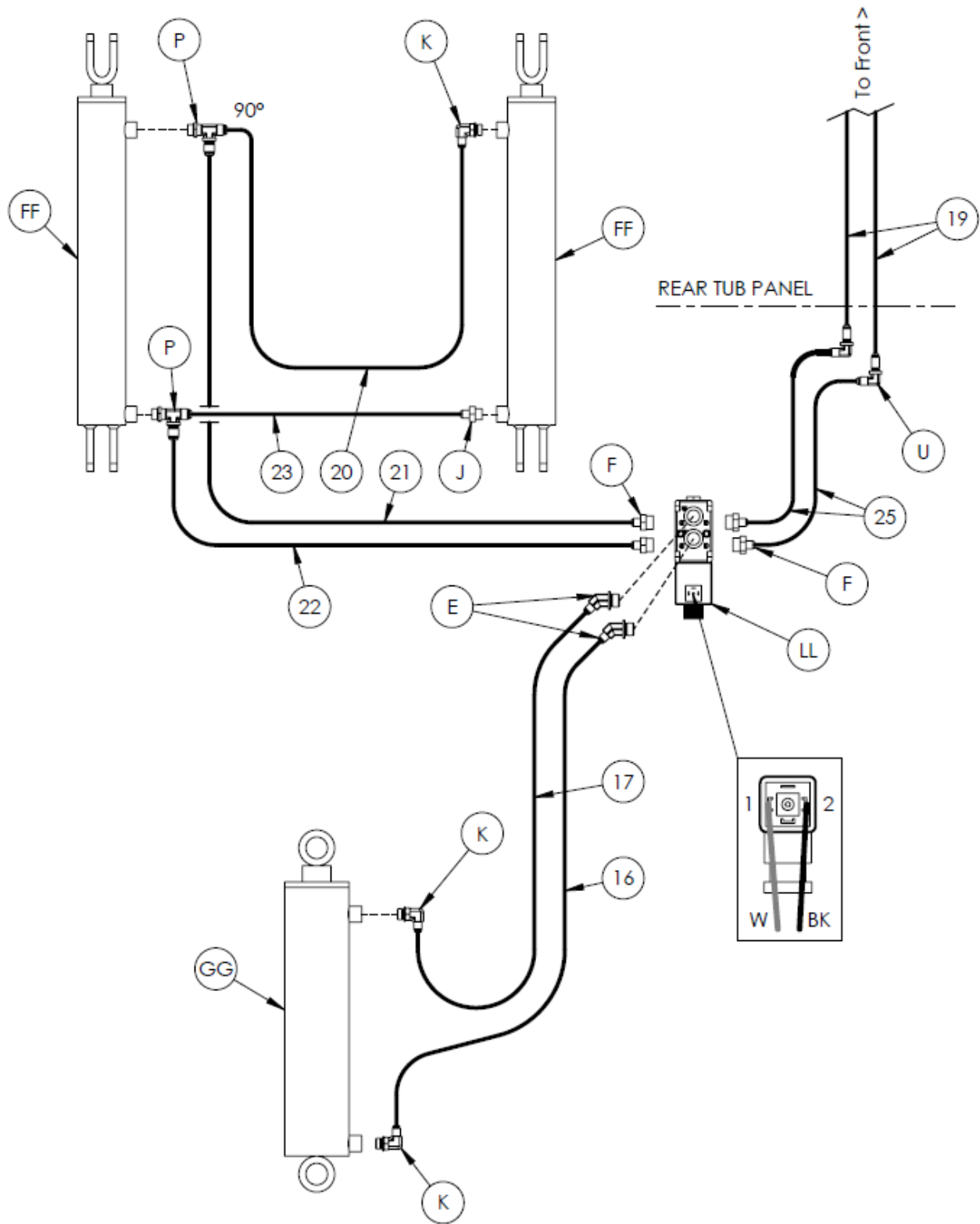

TR GRAIN TANK KIT

