

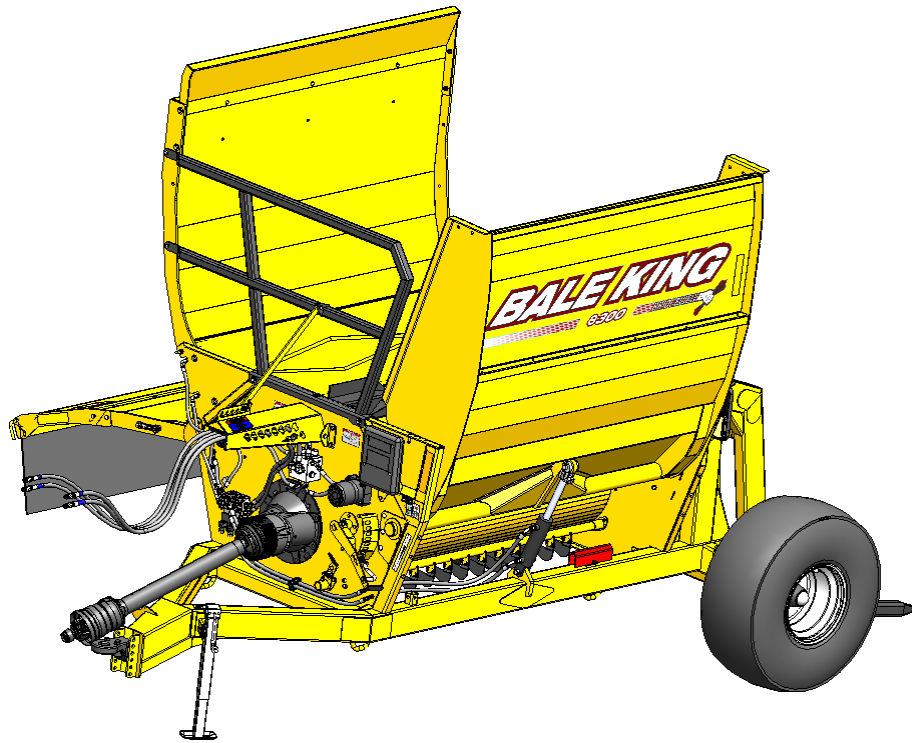

**BRIDGEVIEW MFG. INC.**



***BALE KING 8300***  
***Round and Square Bale Processor***

***Operator's & Parts Manual***

Last Updated: November 2025

**Bridgeview Manufacturing Inc.**  
P.O. Box 4  
Gerald, Saskatchewan, Canada  
S0A 1B0  
Phone: 1-306-745-2711  
Fax: 1-306-745-3364  
Email: [bridgeview@bridgeviewmfg.ca](mailto:bridgeview@bridgeviewmfg.ca)  
[www.bridgeviewmanufacturing.com](http://www.bridgeviewmanufacturing.com)

**Your Authorized Dealer**

**Your Serial Number**

The Serial Number is located on the front tub panel, next to the operator's manual box.

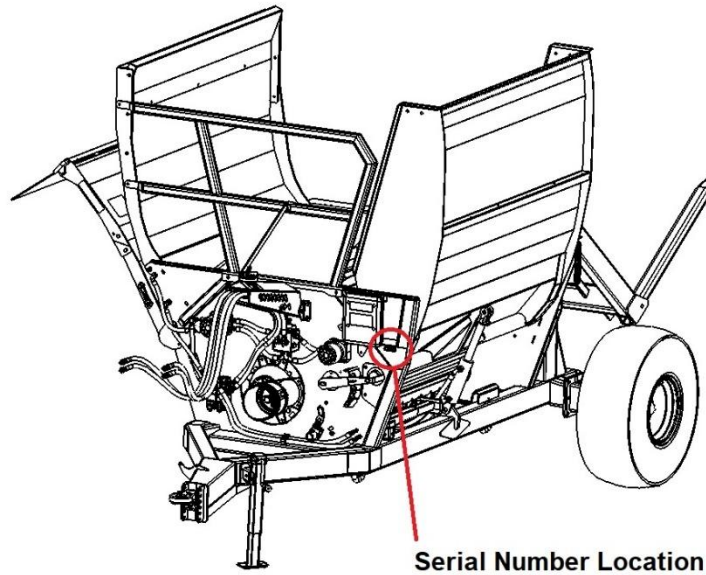

|   |   |
|---|---|
|  | <p><b>⚠ WARNING</b></p> <p>Failure to read and understand operator's manual &amp; all safety signs could result in serious injury. Manual must remain with machine.</p> |
|---|---|

## TABLE OF CONTENTS

|  |    |
|--|----|
| INTRODUCTION .....                           | 1  |
| Safety Precautions.....                      | 1  |
| Safety Decals .....                          | 2  |
| Transportation.....                          | 4  |
| FEATURES & OPERATION.....                    | 6  |
| Power Take-off .....                         | 6  |
| Hydraulics .....                             | 10 |
| Hose Holder .....                            | 11 |
| Implement Tongue .....                       | 12 |
| Rear Forks .....                             | 12 |
| Loading Bales .....                          | 13 |
| Wing.....                                    | 14 |
| Setting the Processor.....                   | 16 |
| Hoop Grate Adjustment .....                  | 16 |
| Bale Roller Speed .....                      | 17 |
| Rotation Direction.....                      | 17 |
| Deflector .....                              | 18 |
| Optional Fine Chop Kit.....                  | 20 |
| Optional Back-up Camera.....                 | 21 |
| SERVICE AND MAINTENANCE.....                 | 22 |
| Greasing Locations .....                     | 22 |
| Tires .....                                  | 25 |
| Twine Removal.....                           | 26 |
| Gearbox and Flail Replacement Procedure..... | 28 |
| Troubleshooting Guide .....                  | 29 |
| Features and Specifications.....             | 30 |
| PARTS MANUAL.....                            | 32 |
| Hydraulic Schematics .....                   | 66 |

## **INTRODUCTION**

Thank you for purchasing a **Bale King** bale processor. With the proper operation and service as outlined in this manual, the Bale King will provide you with years of trouble free operation.

This is a complete safety, operation and parts manual for the Bale King 8300. The manual covers in detail how to safely and effectively use your new processor. The procedures outlined in this manual should be followed to ensure safe operation and longevity of your machine. The parts manual covers all parts you may need to order in case of accident or breakdown. Please read completely through this manual before beginning operation of your new machine.

### ***Safety Precautions***

**The following safety precautions MUST be followed to ensure safe operation of the Bale King Bale processor.**

- **ALWAYS** turn **OFF** the tractor when leaving the operating platform.
- **DO NOT** stand in front of the discharge chute while the machine is running.
- **DO NOT** walk or move under the bale forks or wing when in the upward position, unless the cylinder safety locks are in place.
- **DO NOT** enter the machine while in operation.
- **DO NOT** clean machine while in operation.
- **DO NOT** stick any device into the machine to clear debris while the machine is in operation.
- **ALWAYS** turn off the machine when cleaning the machine, removing twine, or hooking/unhooking the machine
- **ALWAYS** use safety chain when towing the machine on the highway.
- **DO NOT** operate if any part of the **PTO safety shielding** is missing or is not secured.

## Safety Decals

### Power Take-off:

The operator must obey all safety labels and must maintain the proper shielding. A high percentage of drive-line injuries occur when safety shielding is missing or not functioning properly.

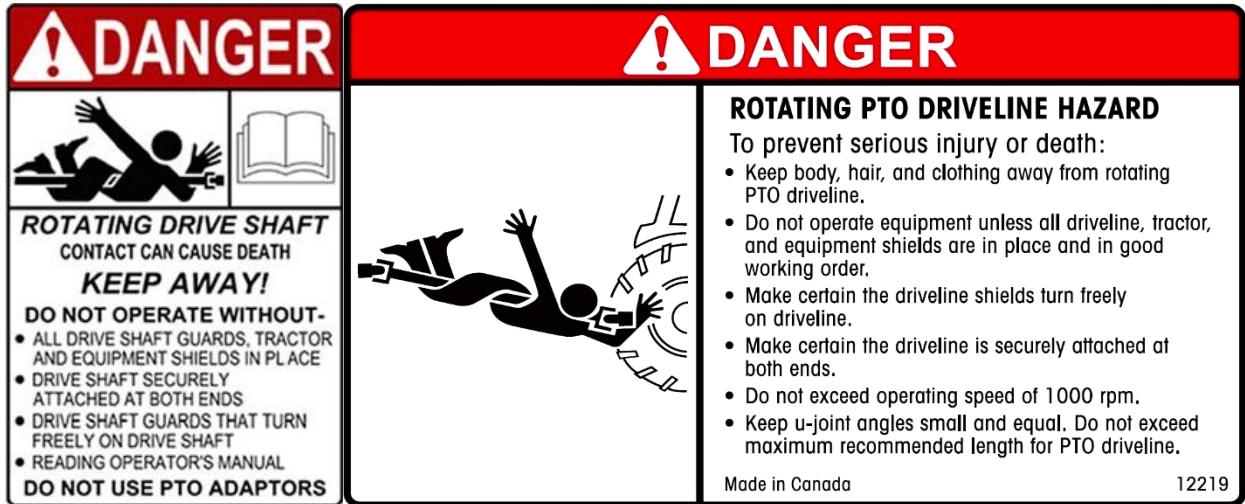

**DANGER:** *Contact with a rotating drive-line can cause serious injury or death.*

### Discharge:



**DANGER:** *Do not stand on the discharge side of the machine while it is in operation.*

### Rear Fork Lift Area:



**DANGER:** *Stand clear of lift area. Do not stand under the forks if tractor is running or if bale is resting on forks. Automatic hydraulic safety locks are installed.*

### Deflector Safety Lock:

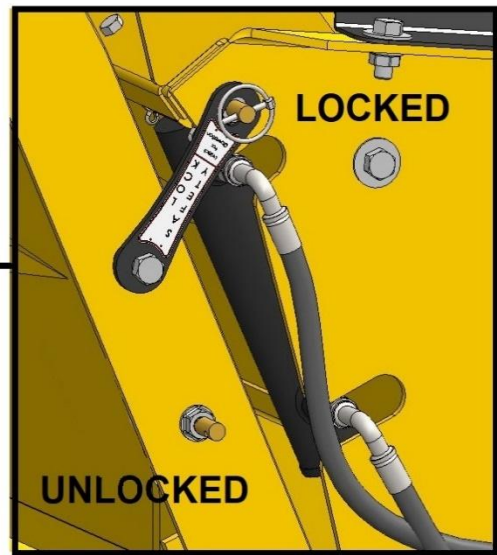

*Unlock for operation. Lock for transport and storage*

## ***Transportation***

The Bale King 8300 can be safely towed on public roads, provided the following precautions are met:

### **Weights and Dimensions**

- The towing vehicle must be suitable for the weight being towed.
- Check with local authorities regarding transport on public roads. Follow all applicable laws and regulations.
- Be aware of your size and weight. Adjust your driving accordingly

| <b>8300</b>  | <b>Empty</b> | <b>Loaded</b> |
|--------------|--------------|---------------|
| Total Weight | 5130 lb      | 8700 lb       |
| Hitch Weight | 1630 lb      | 2200 lb       |
| Length       | 15'-8"       | 19'-4"        |
| Width *      | 10'-4"       | 10'-4"        |
| Height       | 10'          | 12'-3"        |

\* NOTE. Width can be reduced to 9' by folding the deflector

### **Speed**

| <b>Tow Vehicle Weight</b> | <b>Empty Processor</b> | <b>Loaded Processor</b> |
|---------------------------|------------------------|-------------------------|
| 10000 lb and Under        | 32 km/h (20 mph)       | Not recommended         |
| Over 10000 lb             | 40 km/h (25 mph)       | 32 km/h (20 mph)        |

- The processor features implement tires and hubs and is not suitable for high speed travel
- The processor does not have brakes.
- Slow down for rough conditions, turns, and steep declines.
- If towing long distances, ensure the machine is empty (no bales in tub or on fork)
- If hauling one bale only, place it in the tub instead of on the fork.
- If hauling two or more bales, speed should be further reduced. Note that there will be a significant amount of weight behind the processor axle, causing more “tail whip”. This also raises the center of weight of the machine.
- Failure to heed these warning may result in loss of control or death.

**Safety Chain, Jack, PTO, and Hydraulics**

- ALWAYS ensure that the safety chain is properly installed. There should be enough slack to allow for turning, but not so much that the chain drags on the ground.
- Ensure that the jack is installed in its storage position on the front tub wall.
- Ensure that the PTO and hydraulic hoses are properly secured
- PTO and hydraulic lines must be connected to the tractor during transport.
- If towing with a pickup, the outer PTO shaft must be removed, and the inner shaft and hydraulic hoses properly secured. The exposed end of the inner PTO shaft should be covered to protect the splines from dust/rocks, etc.

**Wheels and Tires**

- Check tire pressure and wheel torque. Wheels must be retorqued after 1 hr if being transported for the first time.

|                      |        |                     |           |
|----------------------|--------|---------------------|-----------|
| <b>Tire Pressure</b> | 24 psi | <b>Wheel Torque</b> | 125 ft-lb |
|----------------------|--------|---------------------|-----------|

- If transporting long distances, periodically check the tires and hubs for high temperatures. If heating up, you must slow down.

**Lights and Marking**

- Tow vehicle must have a 7-pin round trailer plug
- Plug in lights and check for proper function and visibility (flashing amber lights, red tail lights and brake lights).
- If towing with a pickup, an adapter will be required to plug into the trailer plug. When braking, both amber lights should activate. Tail lights should always be on.
- Ensure that the supplied SMV (Slow Moving Vehicle) sign is clearly visible from the rear
- Ensure that the reflective markers are cleaned, and visible from all sides

**Safety Locks**

- Lift the forks all the way up. If carrying a bale, only lift enough for appropriate ground clearance.
- If possible, the deflector should be in the folded position.
- Ensure that the deflector safety lock is installed



## FEATURES & OPERATION

### **Power Take-off**

The Bale King bale processor has a PTO shaft which is splined on both ends. The implement end uses a 1-3/4"-20 spline with wedge lock bolts. Install onto the gearbox and tighten the wedge bolts. The bolts should be torqued to **160 ft-lb** and re-torqued after 8 hrs of use.

The tractor end comes standard with a 1-3/8"-21 spline quick detach constant velocity joint. An optional 1-3/4"-20 spline yoke is available through your Bale King dealer.

|  |
|--|
| <p><b>MAXIMUM 150 HORSEPOWER<br/>TRACTOR PTO</b></p> |
|--|

**NOTE:** *Spread yokes and twisted drive shafts are signs of OVERLOAD, not a manufacturer's defect and therefore not covered by warranty.*

- **DO NOT** operate the machine using a spline adaptor. Use of adaptors will **void warranty** due damage caused to to the tractor PTO, PTO driveshaft, or implement.
- **DO NOT** operate at 540 rpm, or use any kind of adaptor to connect to a 540 rpm spline.
- **Always** ensure that the PTO shaft is attached securely to the tractor. When the processor is not hooked to the tractor, store the shaft on the PTO holder.
- **DO NOT** transport the processor without securing the PTO shaft. It may bounce off the holder and be damaged.
- **ALWAYS** ensure that the drawbar is adjusted to **16"** from the end of the tractor PTO shaft to the center of the hole in the drawbar.

### **Operation**

To engage the rotor for processing a bale, be sure the PTO shaft is properly connected to the tractor. Engage the PTO at idle. After the PTO is fully engaged, increase PTO speed until it reaches 1000 RPM.

The processor must not run at any speed less than 1000 PTO RPM as it may result in the flails springing back against the rotor after they come in contact with the bale. This "**backslap**" may cause flails to fatigue and excessive vibration which may cause the bearings to fail. Bales may be dumped into the tub while the rotor is stopped or while it is running at full speed.

## Shear Bolt

All new Bale King processors are equipped with a **shear bolt** clutch located at the implement end of the PTO shaft. The correct size shear bolt is **3/8 x 2" Fine Thread Gr.5 with Stover Lock Nut**. Any other size or grade will **damage** the shear assembly. Spare shear bolts are shipped with each new machine and are stored along the front top lip of the tub.

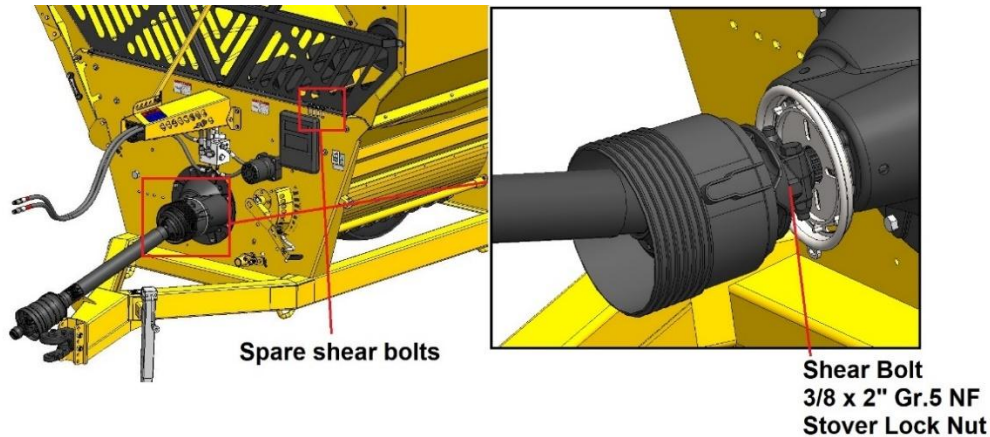

If your shear-bolt is shearing excessively you may be over-loading the machine. If this occurs raise the grate assembly to make the machine less aggressive, or roll the bale more slowly. **Always ensure that your machine is running at 1000 PTO RPM.**

**NOTE: Please consult your local dealer to help pinpoint any problems.**

## PTO Holder

A PTO shaft holder is standard with your new Bale King, for safe storage of the PTO shaft when the processor is not in use.

When unhooking the PTO shaft from the tractor, retract and then swing the PTO to the right to rest the PTO on the holder.

DO NOT transport the machine with the PTO in the holder. Slide the outer PTO shaft out and secure elsewhere. When transporting, fasten the inner PTO shaft to the machine and cover the open splined end.

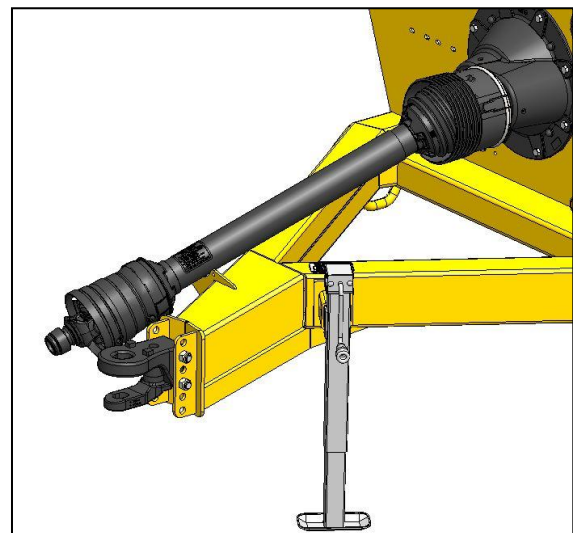

## PTO Use and Maintenance

Shut **OFF** the tractor engine and remove the key before doing any maintenance on the machine. Use **ONLY** genuine **Weasler** parts when replacing any worn or damaged PTO components.

### *Length:*

Confirm the minimum and maximum working lengths of the drive-line. The telescoping tubes must overlap at least 1/3 of their length when in use. The PTO is designed to be used with a drawbar length of 16" from the end of the PTO shaft. Adjust your tractor accordingly.

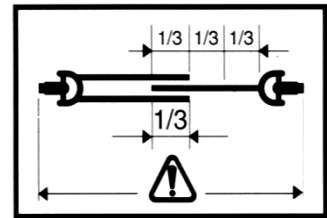

### *Shielding:*

Be sure that the shielding is not damaged and rotates freely on the drive shaft.

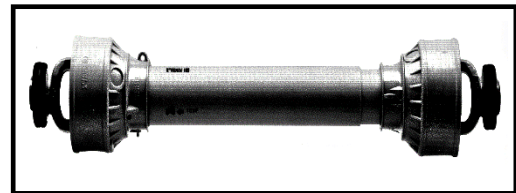

### *Working Angles:*

Constant Velocity joints can operate up to 80 degrees for short periods of time. Do not operate for long periods on sharp angles.

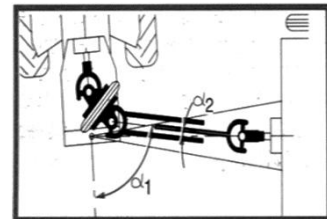

### *Attachment:*

Be sure the drive-line is properly attached tight on the implement input shaft and on

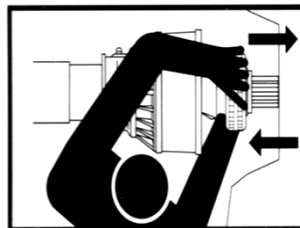

and all bolts and screws are the tractor PTO shaft.

### *Storage:*

When not in use, cover or protect the drive shaft from the weather. When removed from the machine store both halves together to prevent damage. Check all components for proper function and lubrication before use.

**BEFORE ATTEMPTING ANY REPAIR PROCEDURES,  
ALWAYS USE APPROPRIATE EQUIPMENT SUCH AS  
SAFETY GLASSES, SAFETY SHOES, AND GLOVES**

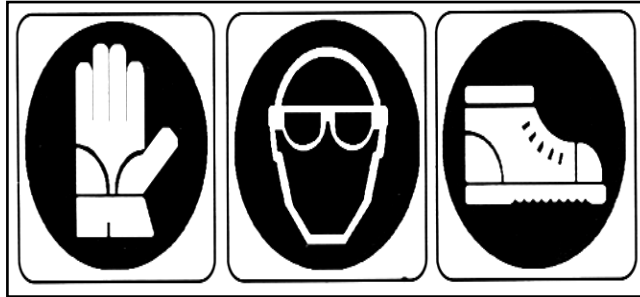

*Shield Removal:*

- To remove the shield, pop out the red snap, then rotate the guard on the bearing to line up the three tabs with the openings and pull it off away from the knuckle joint.
- Remove the nylon bearing from the shaft by spreading it open.

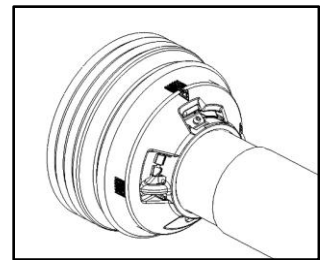

*Shield Assembly:*

- Be sure to lubricate the groove in the inner yokes where the shield bearing rides. Reinstall shields in the reverse order that they were removed.

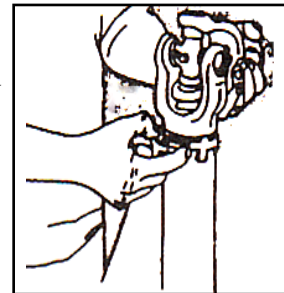

*Lubrication:*

- Be sure to follow the lubrication timeline as outlined on page 22.
- Use low temperature grease if operating in cold temperatures. This will allow the PTO splines to slide much easier in these conditions.

## Hydraulics

**WARNING:** *Pressurized hydraulic fluid can cause serious injury.*

- When working with hydraulic equipment, eye and hand protection should be worn.
- Do not test for leaks with bare hands.
- Relieve any pressure before removing a hose or fitting.
- Never work under components raised by hydraulic equipment unless supported externally.

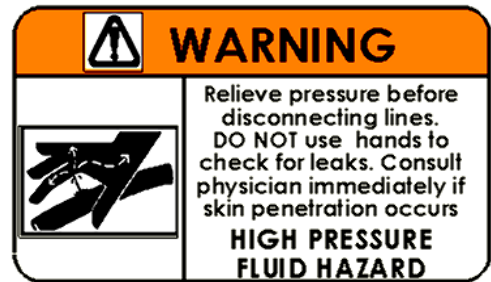

Two diverter valves are installed on the Bale King 8300 to allow the machine to operate using only two sets of hydraulic hoses. The function of the remote is then determined by the control box switch. Each hose that connects to the tractor has a colored marker to identify its function. They should be connected at best convenience for the tractor's controls.



| Control Box | Hose Function           |                 |                |
|-------------|-------------------------|-----------------|----------------|
|             | “AUXILIARY”             | “FORK”          | “DEFLECTOR”    |
| Long Blue   | Lift wing               | Lifts rear fork | Lift deflector |
| Long Red    | Turns rollers clockwise |                 |                |

Always set the tractor's hydraulic flow at a lower rate and adjust it upward until the desired speed is reached. Excessive oil flow may damage the flow divider cartridge

## Hose Holder

The hydraulic hoses may need to be adjusted to avoid damage from rubbing on the PTO shaft. This can be done by lifting or lowering the hose holder. Loosen the pin handle, then lift the end of the hose holder to drop the pin into the slot. Then adjust the height as desired and catch the pin into the desired notch. Finally, retighten the pin handle to prevent it from switching positions if the machine bounces.

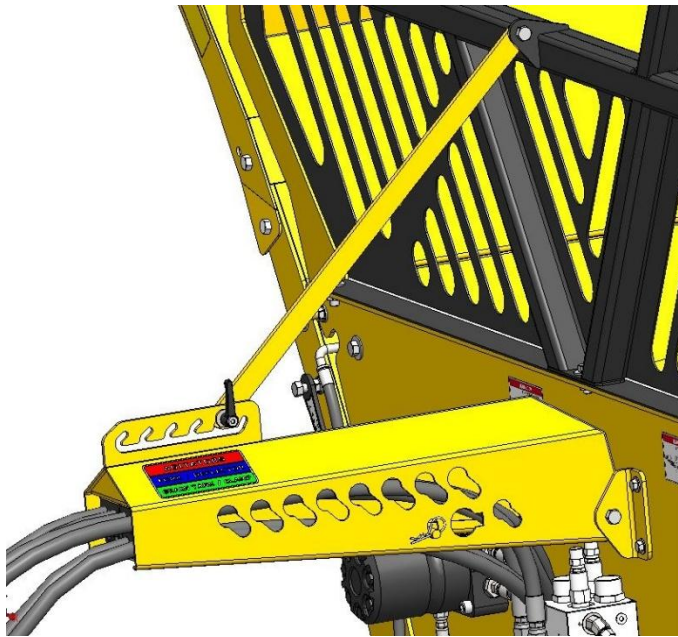

Loosen handle  
Lift end of holder  
Slide pin in slot  
Choose setting  
Tighten handle

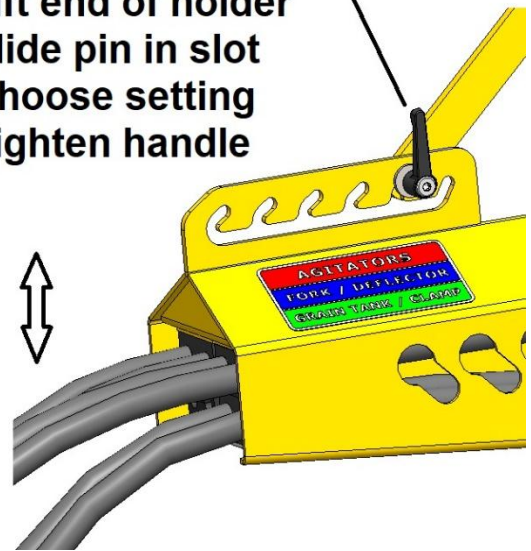

## Implement Tongue

The adjustable hitch on the Bale King features a cast single tongue with optional clevis insert (BMI #29786). This allows for use with tractors equipped with a hammer strap or with a single drawbar. It also allows the machine to move independently over rough terrain without bending the draw pin.

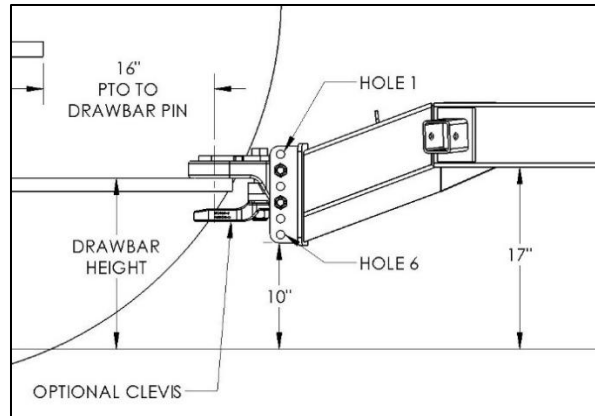

- Make sure that the drawbar is set to **16 inches** behind the PTO shaft for proper PTO length.
- Adjust the hitch height to match the drawbar height and allow the machine to sit level.
- **DO NOT** install the clevis insert if using a tractor with a hammer strap as this will bend the hitch pin
- **ALWAYS** connect the safety chain during road transport

| Drawbar Height | Holes |
|----------------|-------|
| 17.5"          | 1 & 3 |
| 16"            | 2 & 4 |
| 14.5"          | 3 & 5 |
| 13"            | 4 & 6 |

## Rear Forks

The rear fork bale tines can be adjusted side to side by removing the pin connecting the tine to the machine and replacing the tine in the other available gap. The widest position is recommended for all situations, except for the smallest bales. Always use tines in the same position on either side to keep the load on the forks and cylinders balanced.

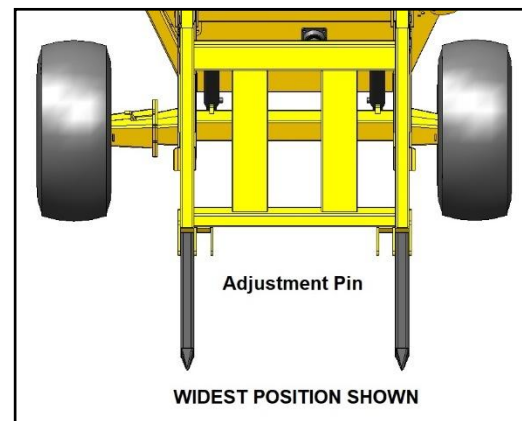

***For transport, and safety when working under the forks, the Bale King 8300 is equipped with hydraulic safety valves that do not allow the forks to come down without hydraulic pressure. Lowering the forks using the tractor controls overrides this valve and allows the forks to lower. Never stand under the forks. When greasing or servicing around the rear end, the forks should be down. Never attempt to loosen or replace hydraulic hoses while the forks are up.***

## Loading Bales

The Bale King 8300 is designed to process both round and square bales. The same procedure is to be followed for loading either type of bale.

- Position the tractor and the Bale King lined up to back straight into the row of bales. To avoid having large square bales hit the tub wall, load the bale slightly towards the wing side.
- When close to the bale, lower the forks and wing completely (you will feel a light vibration as the forks bottom out against the frame.)
- Back completely under the first bale.
- Allow the tractor to move forward while lifting the bale, because the bale fork moves away from the machine while loading.
- If you are loading from the same row you can dump the bale into the machine and back straight into the second bale. If you are going to a different stack for the second bale only raise the first bale enough to clear the ground. Move to the next row and align the machine to the bale before dumping the bale into the tub. This gives you good visibility to line up to the second bale.
- Once you have the first bale in the tub and the second bale on the forks, raise the wing completely, and the bale fork about 1/4 of the way up. You can now transport to your feeding or bedding area to begin processing.



**Note:** Carry the bale as low as possible to lessen the stress on the cylinder shafts. Carrying the bale too high may bend hydraulic cylinder shafts.

- When the first bale has been processed, it is common practice to leave the rotor running at full speed when loading the second bale into the bale chamber from the rear forks.

## Wing

The Bale King 8300 features a pivoting wing on the left side of the machine to allow loading and processing of square bales. The wing is opened completely to load the bale, and can then be operated to manipulate the bale as required to cut the twines and process the bale. The wing also needs to be opened slightly to load a round bale into the tub. The wing should be closed completely, with the cylinder safety lock installed, for transport or any service work.

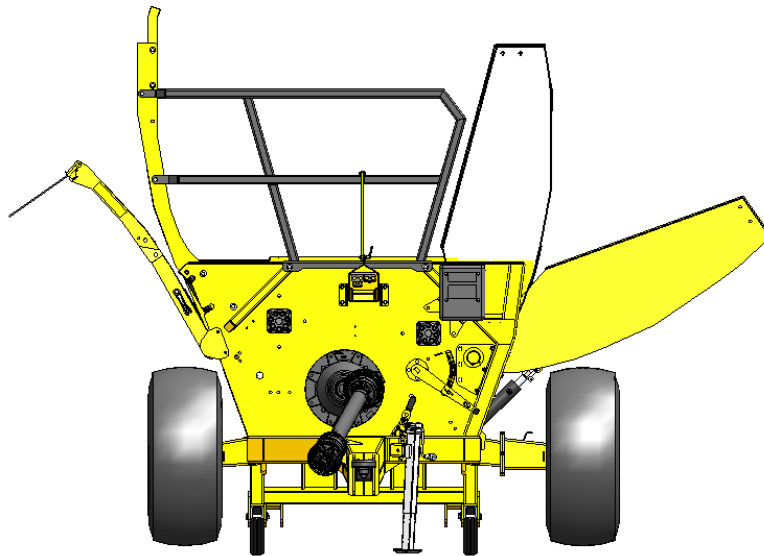

An adjustable wing extension is installed on the discharge side to help contain longer square bales when stood upright. If height is an issue for storage or clearing shed doors, this extension can be brought down to the same height as the top of the folding wing. This gains 8” of clearance. This is done by removing the bolts and sliding the extension down the wing until the second set of holes line up.

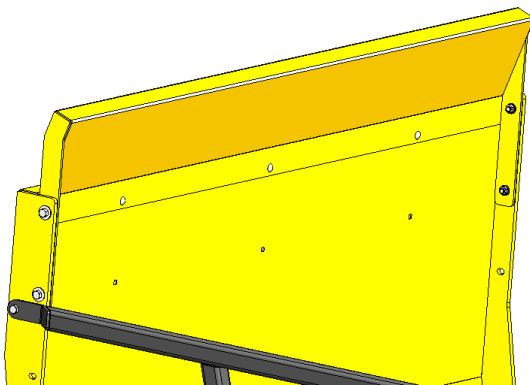

**RAISED**

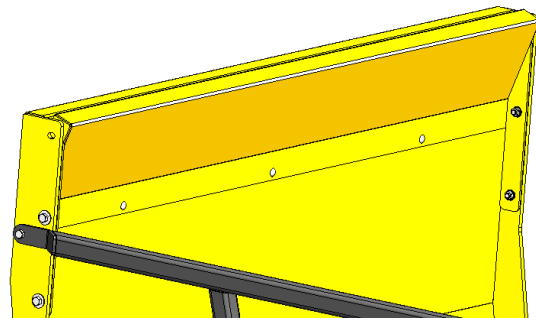

**LOWERED**

An optional wing extension kit (**BMI #35127**) is available to add to the top of the folding wing. This helps when handling longer square bales (over 8.5 ft). It also can be set at different angles, depending on preference.

Adjustment can be done by opening the wing so that the extension is reachable from the ground. Then loosen all 4 bolts, and push the extension to the desired position. Lastly tighten all 4 bolts.

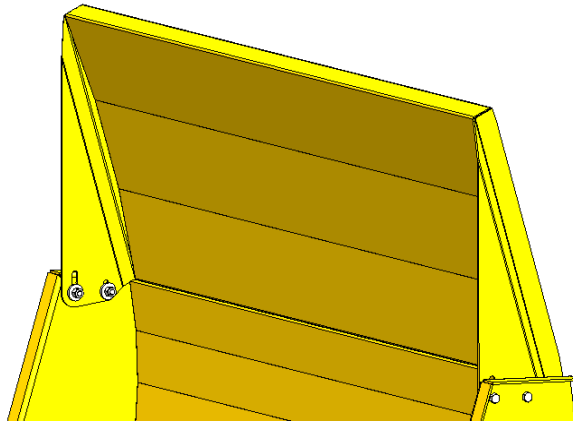

**OPENED**

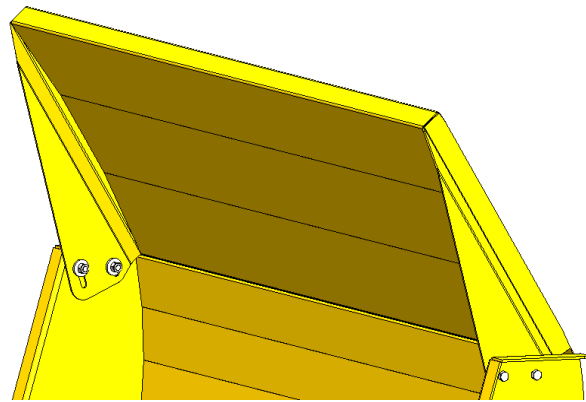

**CLOSED**

## Setting the Processor

Processing speed must be balanced with overall aggression and vibration levels. Excessive continuous vibration may affect the service life of the processor. Processing times of 1-2 minutes are considered normal in dry bale conditions. Extended times are expected in tougher conditions such as high moisture feed, frozen, or misshapen bales. The processor may need to be adjusted for each type of bale for optimal performance. ***Processing a bale too rapidly may cause excessive vibration and driveline damage.***

There are 3 main components to setting the processor:

1. **Hoop grate height:** Adjusts how far the flails protrude above the grate
2. **Bale roller speed:** Adjusts the feed rate to the rotor
3. **Bale rotation direction:** Controls the feed direction over the rotor

## Hoop Grate Adjustment

There are eight adjustment settings for the hoop grate on the bale processor. These settings vary the aggression and length of cut. To adjust, pull the spring handle outward, then swing the handle “UP” for a more aggressive cut, or “DOWN” for less aggression. Then release the spring handle to engage the pin in the desired hole.

When there is a bale in the tub, the bale’s weight will be placed on the hoop grates, making adjustment more difficult. Adjust the machine when it is empty when possible.

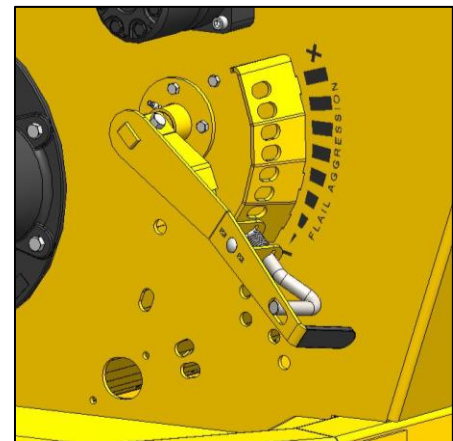

- **Position #1 (Bottom):** Highest grate setting for finest cut and slowest rate of feed. Used for tough processing feeds such as silage bales, or other wet materials.
- **Position #2-6:** Normal operating range. Machine gets more aggressive as handle moves “up”.
- **Position #7-8 (Top):** Lowest grate positions, most aggressive, fastest rate of feed.

The Bale King should be adjusted according to bale conditions to achieve a rate of feed of approximately **1 to 2 minutes**. Light, brittle material such as wheat straw may allow faster processing while tough stringy material such as silage, slough hay, green feed, or flax will require slower processing. Hoop grate adjustment should be checked periodically.

**NOTE:** *Upper grate position should be approximately 0" flail protrusion. Lower grate position should allow 3" flail protrusion.*

## **Bale Roller Speed**

The Bale King is equipped with a flow divider/combiner and two hydraulic motors for turning the bale. Proper roller speed is critical to smooth processing. Roller speed is adjusted via your tractor's flow control. Set a one-minute timer and count revolutions of a roller paddle. 40 RPM is a typical starting point. Speeds of 30 to 45 RPM are considered normal depending on bale conditions.

**If vibration is excessive, slow the rollers and raise the hoops as necessary to adjust.** Excessive roller speed will overload the processor and potentially cause the shear bolt to break. Extended periods of overload may cause driveline damage. Excessive roller speed will also increase loose material build-up on the non-discharge side of the processor. Proper roller speed balances the feed inflow to the rotor with its discharge rate.

## **Rotation Direction**

Turn the bale counter-clockwise (as viewed from the tractor seat) as much as possible. Reverse only as necessary to clear loose material. When turning counter-clockwise, feed flows over the hoop grate, through the rotor, and out the discharge area. When turning clockwise, material is fed both over the rotor and over the non-discharge bale roller into the rotor. This can cause overloading and vibration.

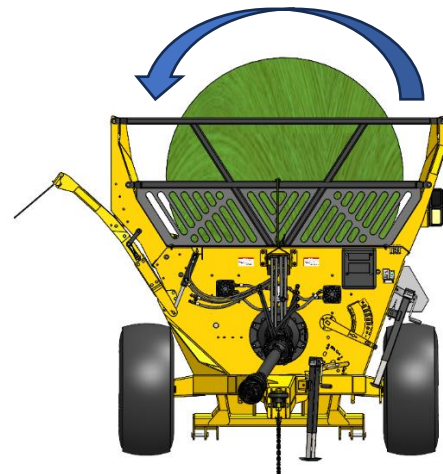

## Deflector

The Bale King 8300 is equipped with a hydraulic side deflector to change the discharge distance and distribution. It also comes with a flipping rubber flap for superior control of the spread pattern.

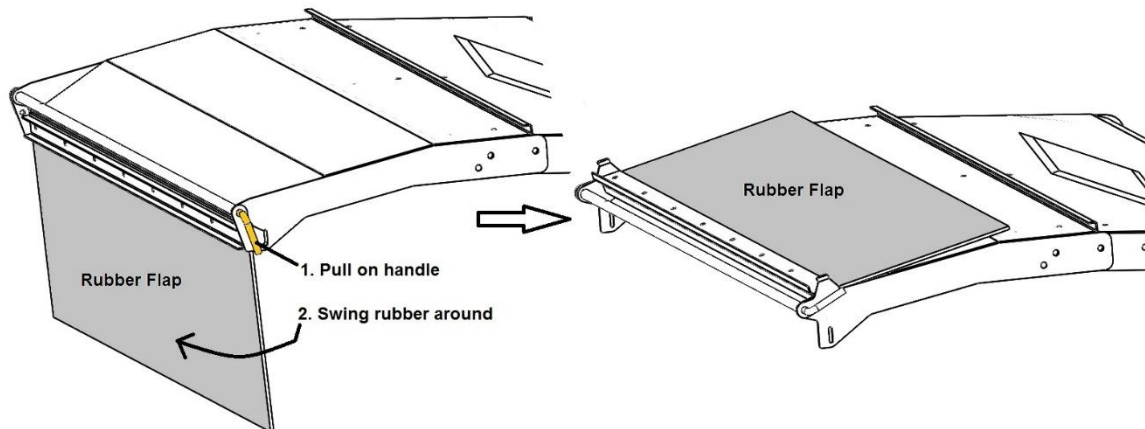

Moving the deflector to the **down** position and flipping the rubber down (above left) will allow the hay to be laid in a windrow, or bunk feeder. Swinging the deflector **up** will allow you to spread straw out over a large area. If you also flip the rubber up (above right), you will be able to "fine tune" the discharge, to control the height and distance.

To flip the rubber, simply pull on the handle and swing into position. Then push the handle so that the tabs catch in the notches and lock into place.

The Bale King 8300 deflector will bunk feed to a distance of 35" from the tire when in the lowest position.

When the deflector is not folded, the transport width of the machine is 10'-4".

For transport and storage, the deflector lock should be put in place by swinging the lock as shown and fastening with a lynch pin.

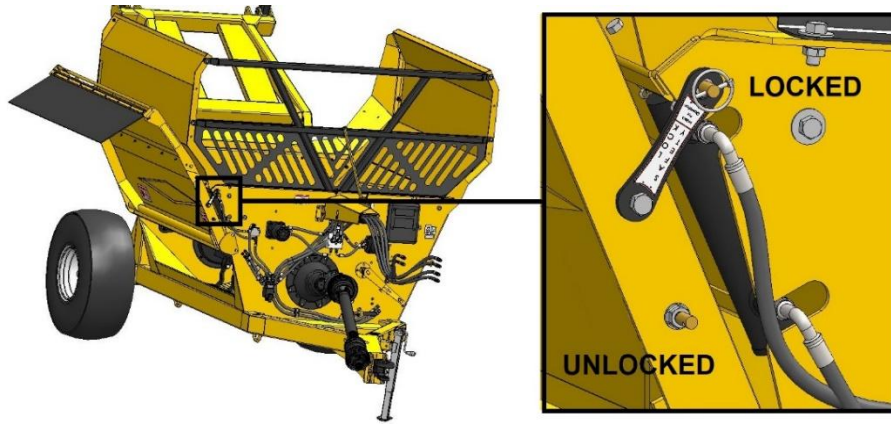

The Bale King 8300 deflector also has the ability to fold for more compact long-term storage or long-distance transport.

- Move the deflector to its lowest position
- Remove the 7 top carriage bolts from the deflector.
- Loosen all the 4 bolts on the front and back of the deflector.
- Raise the deflector to its highest position with the hydraulics. Remove the bolts closest to the machine center (both front and back) and swing the outer deflector down.

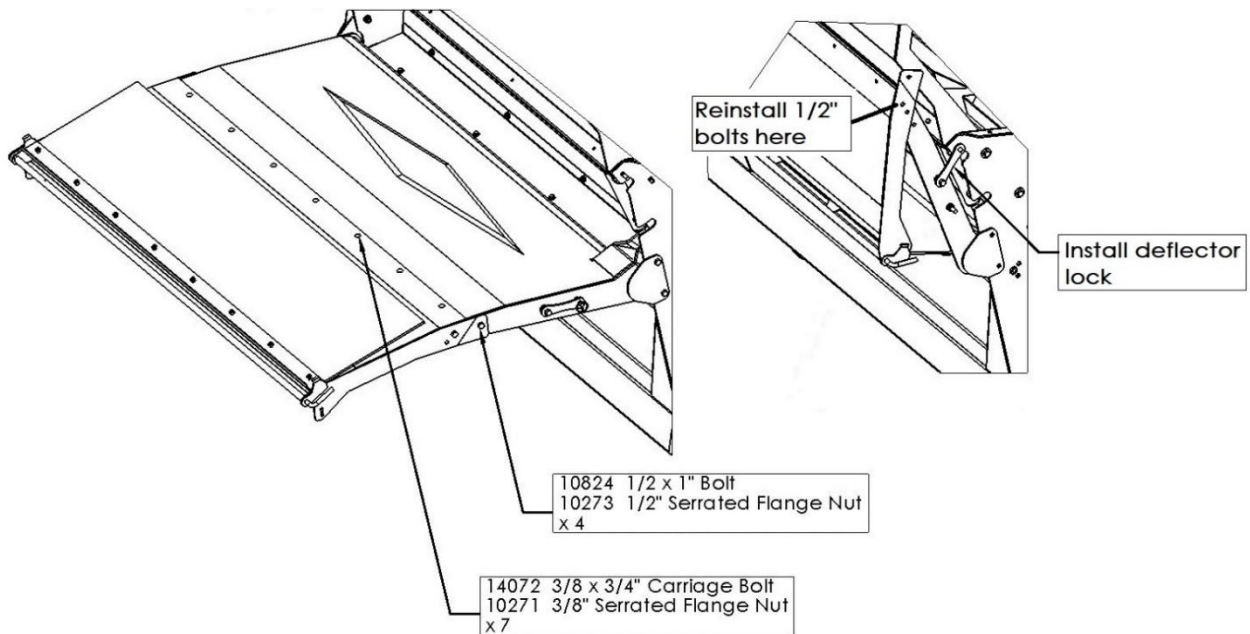

**BE CAREFUL WHEN LIFTING THE DEFLECTOR WITH THE OUTER PANEL ABLE TO PIVOT TO AVOID CONTACTING THE TIRES.**

## Optional Fine Chop Kit

|             |                         |                   |
|-------------|-------------------------|-------------------|
| <b>8300</b> | <b>Fine Chop Option</b> | <b>BMI #36155</b> |
|-------------|-------------------------|-------------------|

The Bale King 8300 processor has an optional fine chop knife kit available to be installed in the lower tub area. This option is available if you require a finer cut on the material which you are processing such as slough hay and silage bales.

It is recommended that the knives be lowered when bedding straw as it will affect your spread pattern. Adjust the machine as needed.

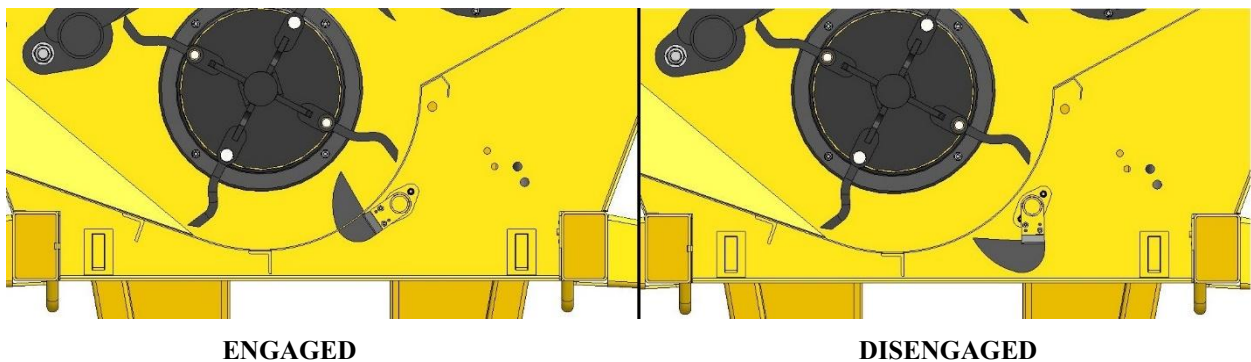

There are two settings for the fine chop, depending on how fine you wish to cut the material. These settings are achieved by pulling the handle towards the back of the machine, then selecting the desired hole.

|          |                          |
|----------|--------------------------|
| <b>0</b> | <b>Disengaged</b>        |
| <b>1</b> | <b>Partially Engaged</b> |
| <b>2</b> | <b>Fully Engaged</b>     |

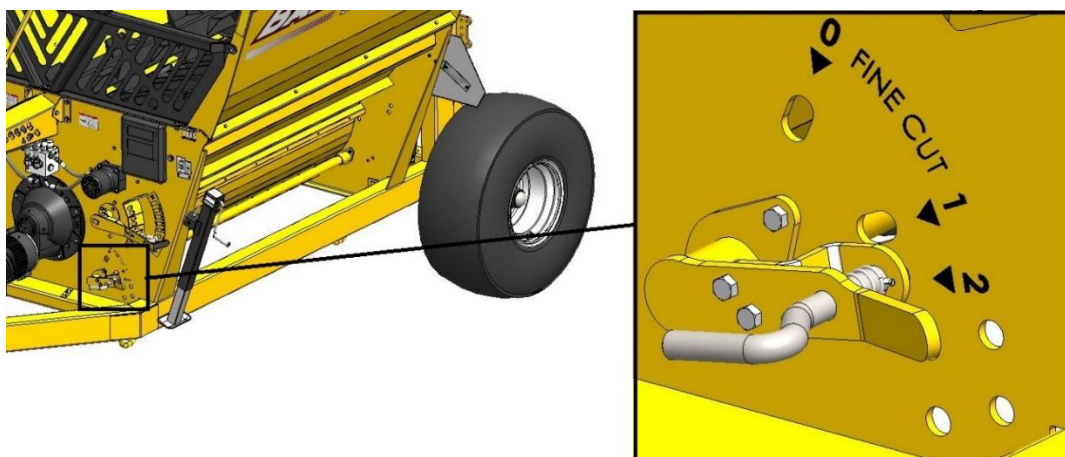

## Optional Back-up Camera

|      |                                 |            |
|------|---------------------------------|------------|
| 5400 | Standard Kit<br>(down to -20°C) | BMI #32619 |
| 5400 | Pro Kit<br>(down to -40°C)      | BMI #32628 |

The Bale King 5400 processor has an optional back-up camera to provide increased visibility while loading bales. This is especially helpful when combined with a 3-bale kit.



The kit includes a mounting bracket to install the camera on the rear axle of the processor, as well as cables to run to the tractor. The monitor can be installed in the tractor cab, with a plug between the tractor and processor.

## SERVICE AND MAINTENANCE

### Greasing Locations

Lubricating the Bale King bale processor should be done on a regular basis.

| Every 50 bales                |                      |   |                               |
|-------------------------------|----------------------|---|-------------------------------|
| C                             | Rotor Gearbox        | 1 | 3-5 pumps                     |
| Every 150 bales               |                      |   |                               |
| A                             | Bale Fork Pivot      | 2 | 3-5 pumps                     |
| B                             | Wing Pivot           | 2 | 3-5 pumps                     |
| D                             | Hoop Handle          | 1 | 3-5 pumps                     |
| E                             | PTO Cross & Bearings | 4 | 5 pumps                       |
|                               | PTO Guard Bushings   | 2 | 5 pumps                       |
|                               | PTO Spline           | 1 | 8-10 pumps                    |
| Every 500 bales (or Annually) |                      |   |                               |
| E                             | PTO CV Joint         | 1 | 30 pumps                      |
| F                             | Roller Bearings      | 2 | 3-5 pumps (DO NOT OVERGREASE) |
| G                             | Rotor Bearing        | 1 | 3-5 pumps (DO NOT OVERGREASE) |
| H                             | Jack                 | 1 | 8 - 10 pumps                  |
| Annually                      |                      |   |                               |
| J                             | Wheel Hubs           | 2 | Pack hubs full                |

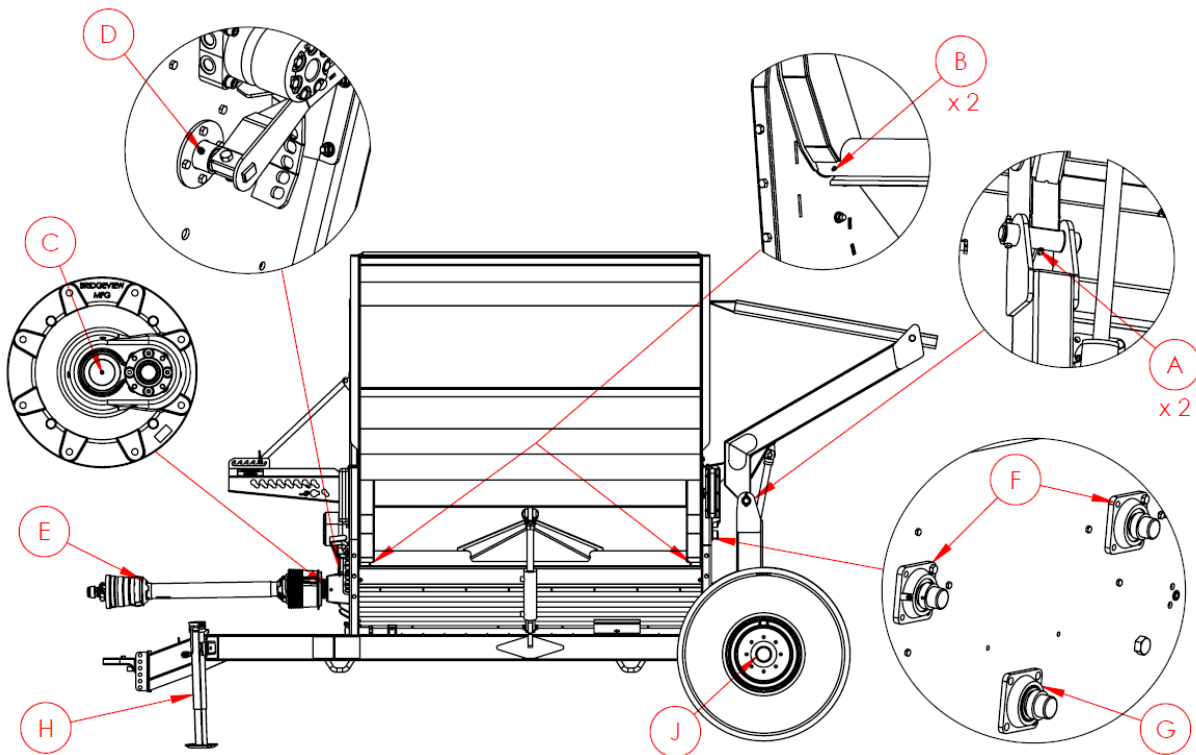

## PTO/Driveline

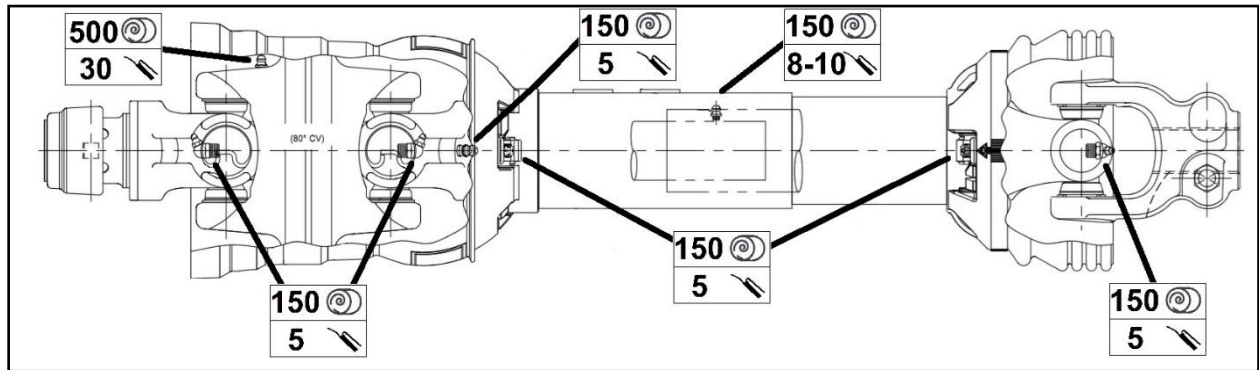

Frequent lubrication is required. Grease the driveline parts as required on the chart.

**After storage** for long periods of time, lubricate and check the function of every driveline component before operating. Failure to grease all the joints will **VOID** warranty.

All zerks can be accessed while the PTO is connected to the tractor EXCEPT for the telescoping spline, which can only be accessed when the PTO is fully retracted.

If operating in very cold temperatures (below -20°C or -5°F), low temperature grease (ex. EP-1 synthetic) should be used, especially where the splines overlap. This will make extending / retracting the shaft much easier and relieve stress from turning.

## Gearbox

There is one grease zerk on the front of the gear box. Apply 3-5 pumps of good quality grease every 8 hours or 150 bales, whichever comes first.

If the gearbox is removed to replace the rotor or perform any other service, add **80 pumps** of grease to the grease zerk upon reinstallation.

The gear box requires GL5 80W90 gear oil. The oil should be filled to the level plug and checked on a regular basis. The oil should also be changed at the following intervals.

- 250 bales after first use
- Every 2000 bales afterwards, or annually (whichever comes first)

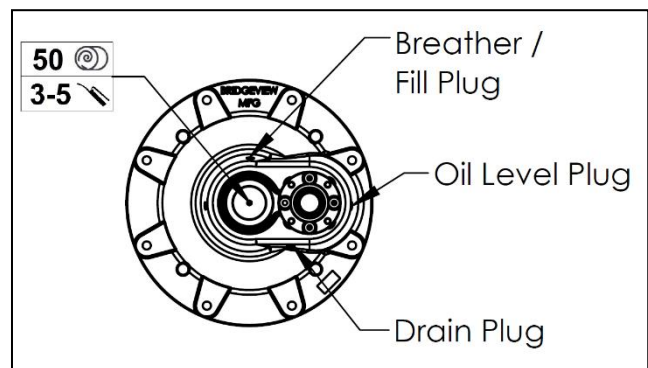

## Cylinder Maintenance

The hydraulic cylinders are easily removed for repair or maintenance simply by:

- Lowering the fork (or deflector) to the down position and unhooking the hydraulic lines. Be sure there is no pressure on the lines and mark the line locations so there is no confusion when reinstalling the cylinders. Check hydraulic schematics.
- Removing the cotter pin closest to the frame of the machine and sliding the cylinder pins out
- To reinstall, reverse the removal procedure

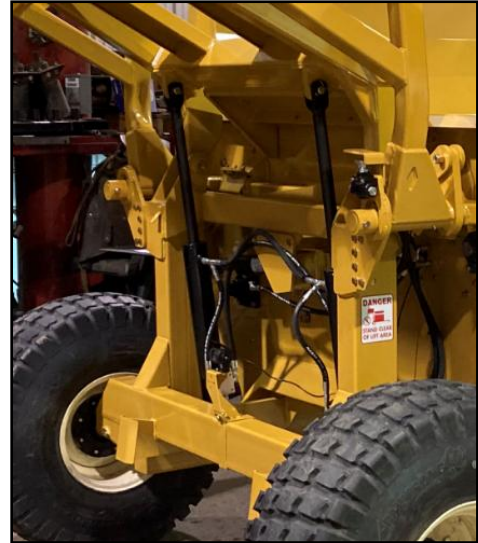

**NOTE:** *Always cover exposed cylinder shafts with grease to avoid rusting of shafts if the unit is not used for extended periods of time. Rusted cylinder shafts are NOT covered by warranty*

**NOTE:** *Check all hoses and fittings periodically for leaks. Tighten or replace any dripping components or any worn out hoses.*

## Tires

Wheel bearings should annually be lubricated and inspected for adjustment. Inspect more often for extensive traveling.

- To tighten the wheel bearings, lift up each wheel (one at a time) until the wheel spins freely
- Remove dust cap and the cotter pin which retains the castle nut
- Tighten the nut until the wheel will rotate approximately two turns when given a firm spin
- Align castle nut to closest hole and insert the cotter pin
- Pack hub full of grease and reinstall the dust cap

Proper tire inflation will help to alleviate puncture problems when towing and operating on rough terrain.

|  |                       |
|--|-----------------------|
| Check for proper tire inflation                  | <b>24 psi</b>         |
| Replace any damaged or worn tires                | <b>16Lx16.1 8-ply</b> |
| Check and tighten wheel bolts on a regular basis | <b>125 ft.lb</b>      |

*Note: Warranty does not cover damaged rims and hubs due to loose wheel bolts or flat tires.*

*Tire warranty is covered by the tire manufacturer.*



*Note: When inflating tires, use a clip-on chuck and extension hose long enough to allow you to stand to one side and NOT in front of or over the tire assembly.*

## Twine Removal

It is natural that twine from the bales will wrap around the rotor as they are being processed. It is recommended to remove the twine from the rotor every 10-15 bales to avoid having so much that it begins to hinder the flail movement. The more often this is done, the easier it is to remove, since the twine has not had a chance to wrap more tightly. The patented “X” shape makes twine removal much easier.

**WARNING:** Before attempting the removal of twine from the rotor, be sure that the machine is stopped and the tractor is shut **OFF**. Place the tractor in park. Twines can be removed with the use of the optional knife, or any other knife.

An electric device is also available from suppliers to melt the twine & allow it to be pulled off. Once melted, the twine should be removed immediately to prevent damage to the rotor. It is **NOT PERMITTED** to leave the twine burning on the rotor as this has several adverse effects:

- It may take the temper out of the steel, rendering it weaker.
- Loose straw and hay remaining in the machine may ignite causing a fire in the processor.
- Excessive buildup of melted plastic.
- Dry out bushings causing them to wear prematurely.

**NOTE:** *Bridgeview Manufacturing Inc. VOIDS warranty for any damage caused by twine burning in the processor.*



Twine guards are installed on the machine to keep bale twine out of important areas such as bearings.

- The wheel hubs have a twine guard to keep anything from getting tangled in the wheel bearing. Check for and remove any twine which may have wrapped around the spindle.

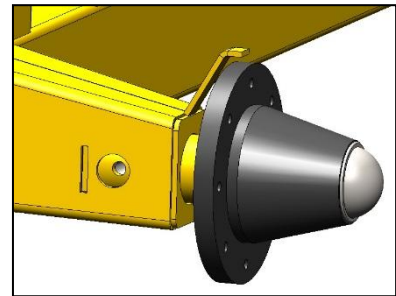

- The main rotor and the rollers are equipped with removable twine guards. The guards are mounted to inside of the front and rear walls of the machine. The twine guards are bolted and need to be removed if you need to remove or tighten the bolts on the bearings or the hydraulic motors.

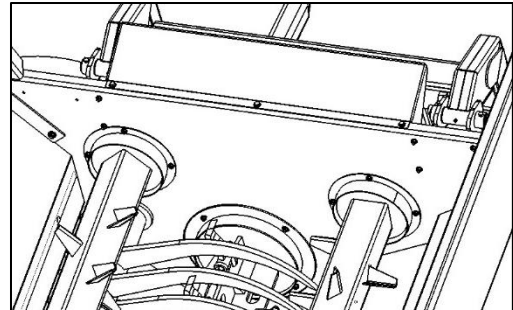

- Remove any twine which may have wrapped around the rollers.

## Gearbox and Flail Replacement Procedure

Flail replacement is accomplished by removing the 3/4" x 4-3/4" bolt holding the flail to the rotor. The flail is then lifted away from the rotor. The bushing can now be removed by using slight pressure to push it out of the flail. Inspect the bolt, bushing, and the flail for wear. If wear is excessive, replace with new parts.

Bridgeview Manufacturing Inc. recommends when changing flails to change in **PAIRS** (opposite each other). Processing bales with broken flails causes the rotor to be out of balance and excessive vibration may cause machine deterioration.

If a new rotor is required, care must be taken when reinstalling:

- Clean the spline and shaft ends of the rotor of any debris
- Clean the inside of the gearbox. Check the splines for damage.
- Slide rear twine guard over the rotor
- Install new rotor bearing (if necessary). Torque to **200 ft-lb**
- Slide the rotor through the rear bearing. Do not tighten collar yet
- Install the gearbox over the rotor spline and bolt to the tub
- Check flail clearance of **1/2 to 5/8"** to tub panel
- Center the rotor in the tub so that the flails are centered between the hoops and slots
- Tighten bearing lock collar **counter-clockwise**. Apply *loc-tite* to the set screw and torque to **100 in-lb**.
- Check gearbox oil to the side plug level (~500 mL). Replace if necessary.
- Add **80 pumps** of grease to the front gearbox grease zerck.
- Install rear twine guard using 3/8" bolts.

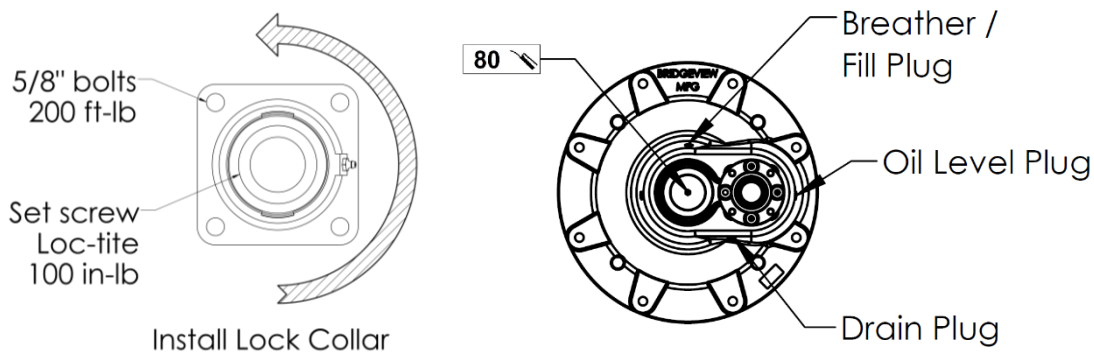
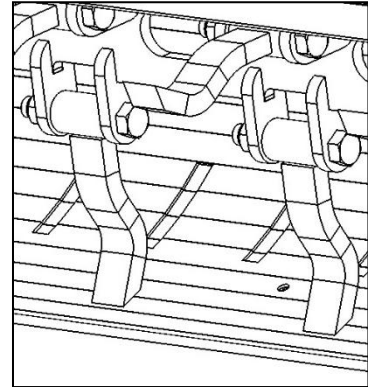

## Troubleshooting Guide

| Problem   | Possible Cause   | Remedy  |
|---|--|---|
| <b>Excessive vibration while processing bales</b> | Overloading rotor  | <ul style="list-style-type: none"> <li>• Set hoops to less aggressive position</li> <li>• Slow rotation of bale</li> <li>• Change direction of bale rotation (counter clockwise as much as possible)</li> </ul> |
|   | Operating machine at less than 1000 PTO RPM                              | <ul style="list-style-type: none"> <li>• Operate machine at rated 1000 PTO RPM</li> </ul>   |
|   | Broken flails causing rotor to be out of balance                         | <ul style="list-style-type: none"> <li>• Replace broken flails (in pairs opposite each other)</li> </ul>  |
|   | Excessive twine wrapped on rotor causing flail movement to be restricted | <ul style="list-style-type: none"> <li>• Cut twine off rotor</li> </ul>   |
|   | Rotor bearing failure  | <ul style="list-style-type: none"> <li>• Replace failed parts</li> </ul>  |
| <b>Excessive shear bolt breakage</b>              | High machine vibration   | <ul style="list-style-type: none"> <li>• See above</li> </ul>   |
|   | Engaging PTO at high engine speed or too quickly                         | <ul style="list-style-type: none"> <li>• Idle tractor to engage PTO then bring up to full operating speed</li> <li>• Feather PTO lever into position</li> </ul>   |
|   | Excessive horsepower   | <ul style="list-style-type: none"> <li>• Use smaller tractor (Max 150 HP)</li> </ul>  |
|   | Incorrect shear bolt used  | <ul style="list-style-type: none"> <li>• Use correct shear bolt</li> </ul>  |
| <b>Bale not turning</b>                           | Excessive loose material in tub causing roller to jam                    | <ul style="list-style-type: none"> <li>• Reverse direction of bale rotation to clean out</li> <li>• Turn bale more slowly</li> </ul>  |
|   | Rotary straw bale bridging across rollers                                | <ul style="list-style-type: none"> <li>• Install rotary straw assist kit</li> </ul>   |
|   | Second bale interfering  | <ul style="list-style-type: none"> <li>• Lower fork slightly</li> </ul>   |
|   | Tractor relief pressure set too low                                      | <ul style="list-style-type: none"> <li>• Set tractor relief pressure to at least 2500 PSI</li> </ul>  |
| <b>A single roller stopping</b>                   | Mechanical flow divider valve not functioning correctly                  | <ul style="list-style-type: none"> <li>• Contact your dealer for repairs</li> </ul>   |
|   | Coupler between motor and roller broken                                  | <ul style="list-style-type: none"> <li>• Replace failed parts</li> </ul>  |

## Features and Specifications

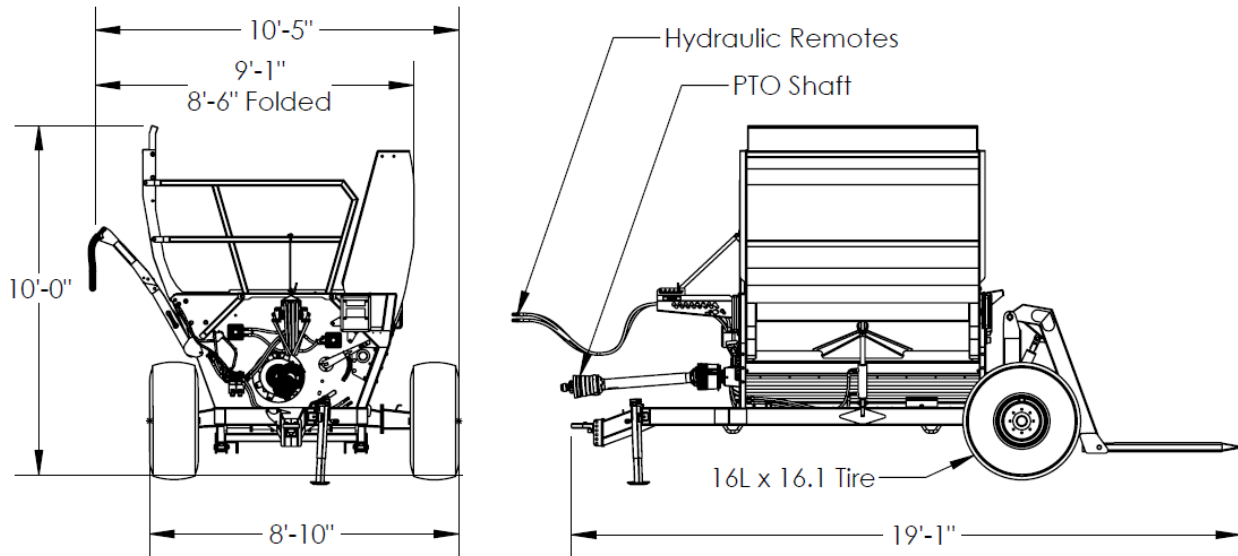

### Dimensions:

|                                |             |
|--------------------------------|-------------|
| Overall Weight                 | 5130 lb     |
| Drawbar Weight                 | 1630 lb     |
| Overall Length (Forks Up)      | 15'-8"      |
| Overall Width (Deflector Down) | 11'-10"     |
| Overall Width (Wing Open)      | 13'-2"      |
| Rotor Extended Tip Diameter    | 27 in.      |
| Discharge Opening              | 12 x 80 in. |

### Wheels:

|                  |                  |
|------------------|------------------|
| Tire Size        | 16L x 16.1 8-ply |
| Tire Inflation   | 24 psi           |
| Wheel Nut Torque | 125 ft-lb        |

### Driveline:

|                             |                              |
|-----------------------------|------------------------------|
| Minimum Horsepower          | 100 HP                       |
| Maximum Horsepower          | 150 HP                       |
| PTO Shaft                   | Weasler: Cat. 6 80 deg. C.V. |
| Shear Bolt                  | 3/8 x 2" Fine Thread Gr. 5   |
| Rated PTO RPM               | 1000 RPM                     |
| Flail Tip Speed at 1000 RPM | 7000 FPM                     |
| Number of Flails            | 28                           |
| Flail Size                  | 3/4 x 1-1/2 x 7 in.          |
| Flail Bushing               | Oil Impregnated Brass        |
| Rotor Shaft                 | 1-15/16" Bearing             |
| Gearbox Oil                 | GL5 80W90                    |
| Gearbox Oil Capacity        | 500 mL                       |

**Hydraulics:**

|                               |            |
|-------------------------------|------------|
| Required Remotes              | 2 Standard |
| Minimum Flow Requirements     | 15 GPM     |
| Minimum Pressure Requirements | 1800 psi   |

**Other:**

|  |  |
|--|--|
| Roller Shaft                               | 1-3/4" Bearings  |
| Twine Guards                               | Rotor, Rollers, Axles                                  |
| Adjustable Bale Fork Width<br>(on centers) | 48 in. or 40.5 in.                                     |
| Adjustable Hitch Height                    | 4 settings at 1.5 in. intervals (13" -17.5")           |
| Discharge deflector                        | Adjustable top and bottom<br>Removable rubber end flap |

## PARTS MANUAL

|                                |    |
|--------------------------------|----|
| Machine Overview .....         | 33 |
| Jack & Hitch .....             | 34 |
| Wheels & Hub.....              | 35 |
| Hub & Spindle .....            | 36 |
| Rotor & Drive Components ..... | 37 |
| Gearbox.....                   | 38 |
| PTO Shaft.....                 | 40 |
| Grates .....                   | 41 |
| Rollers.....                   | 43 |
| Upper Tub Components.....      | 44 |
| Rear Forks .....               | 46 |
| Deflector & Hose Cover .....   | 47 |
| Main Frame.....                | 49 |
| Manual Holder .....            | 51 |
| Hose Holder .....              | 52 |
| Lights & Harness .....         | 53 |
| Twine Cutter (Option).....     | 54 |
| Fine Chop Kit (Option).....    | 55 |
| Back-up Camera Option .....    | 57 |
| Diverter Valve.....            | 60 |
| Decals.....                    | 62 |
| Hydraulic Schematics .....     | 66 |

## Machine Overview

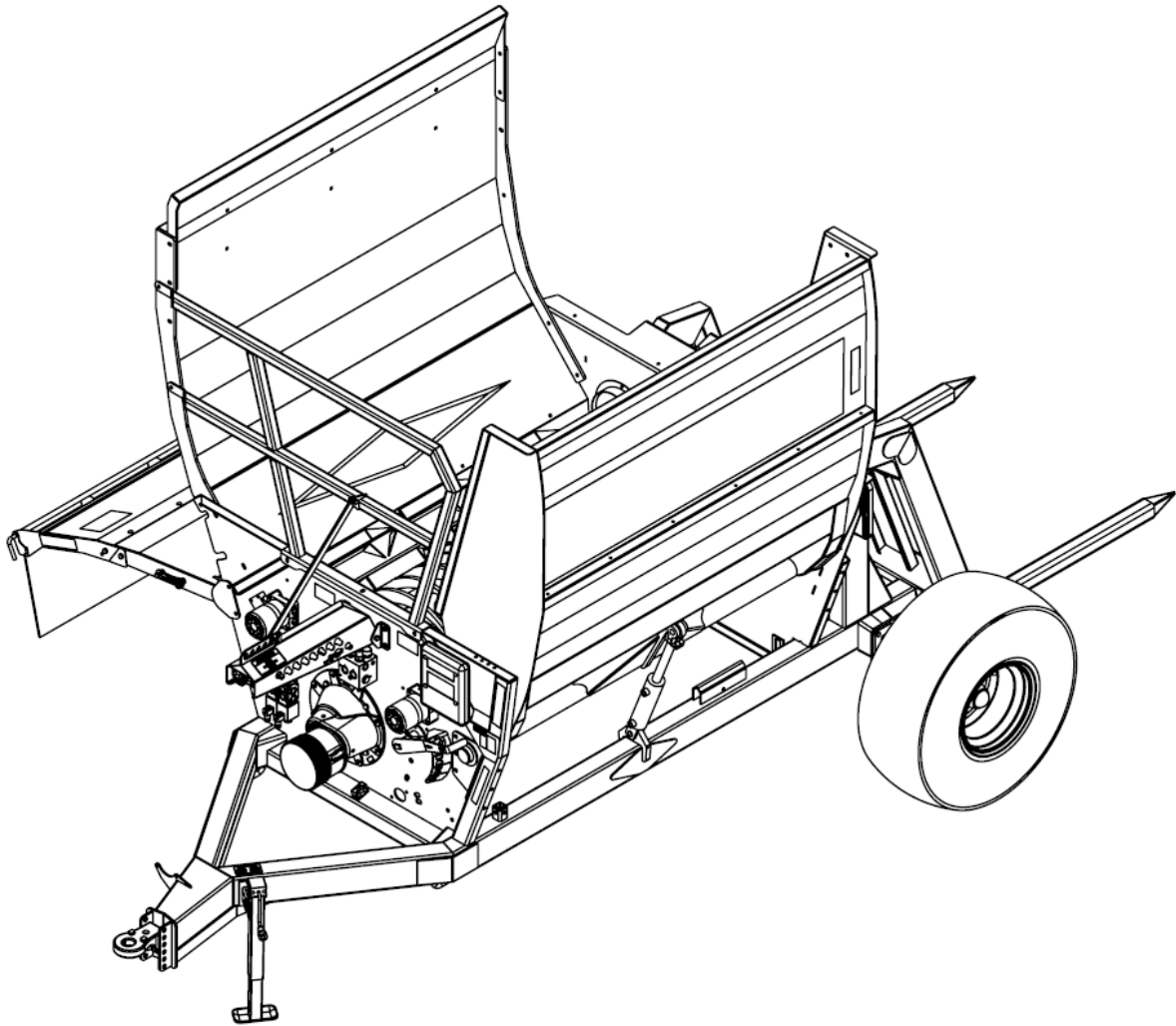

**\*\* CHECK YOUR SERIAL NUMBER BEFORE ORDERING PARTS \*\***  
**\*\* PAY ATTENTION TO SERIAL NUMBER SPLITS WHERE INDICATED \*\***

LEFT AND RIGHT ARE DETERMINED STANDING AT THE REAR OF THE MACHINE  
LOOKING TOWARDS THE FRONT

Per Quantities: A/R = As Required  
Per ID#: NSS = Not Sold Separately

## Jack & Hitch

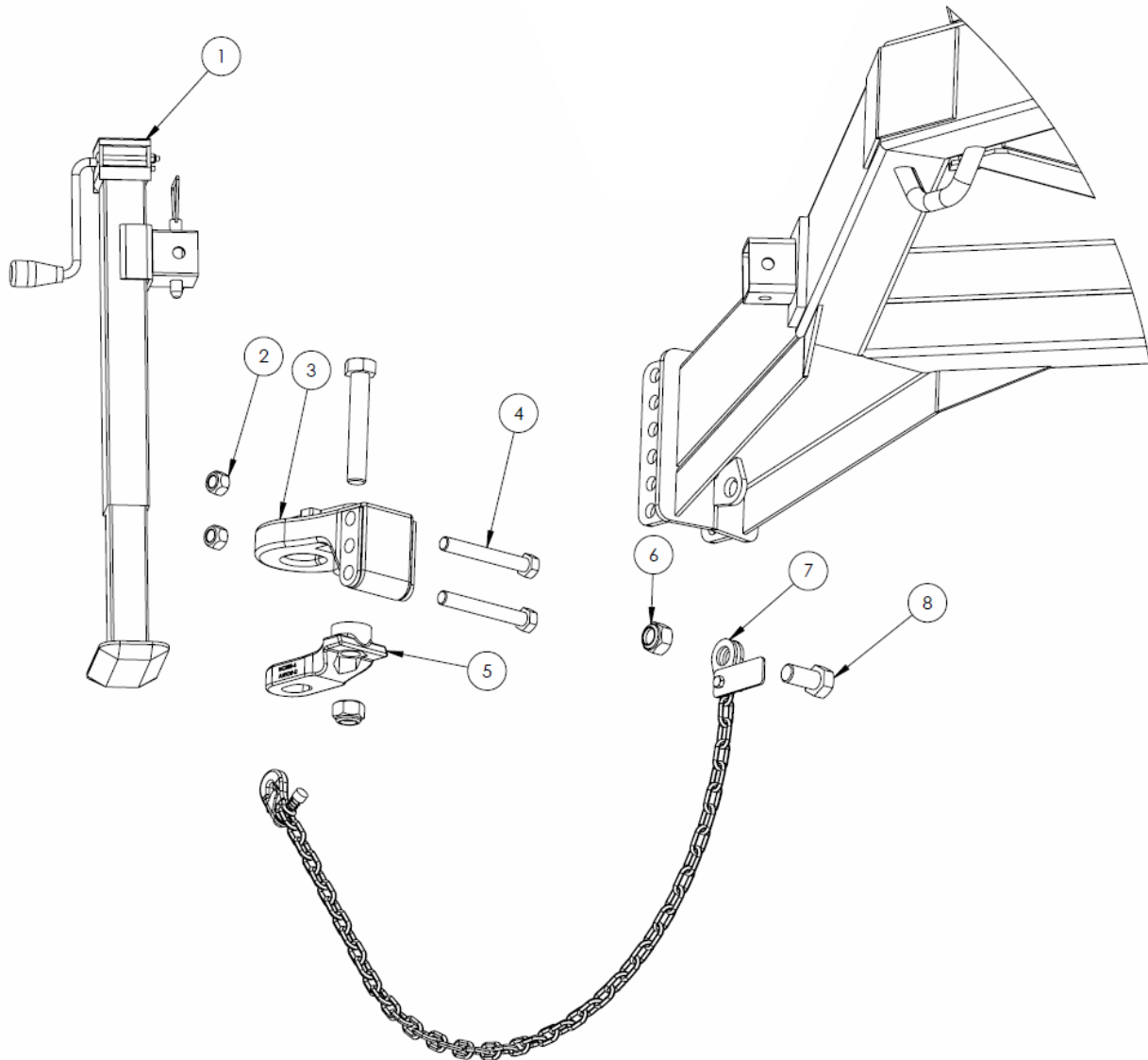

| # | DESCRIPTION                 | PART # | QTY |
|---|-----------------------------|--------|-----|
| 1 | Jack, 5000 lb               | 31637  | 1   |
| 2 | Nut, 3/4" Stover Lock       | 11823  | 2   |
| 3 | Hitch Tongue                | 29785  | 1   |
| 4 | Bolt, 3/4" x 5-3/4"         | 10802  | 2   |
| 5 | Hitch Clevis Kit            | 29786  | 1   |
| 6 | Nut, 1" Stover Lock         | 21746  | 1   |
| 7 | Safety Chain, 11000lb x 53" | 21715  | 1   |
| 8 | Bolt, 1" x 2"               | 18992  | 1   |

## Wheels & Hub

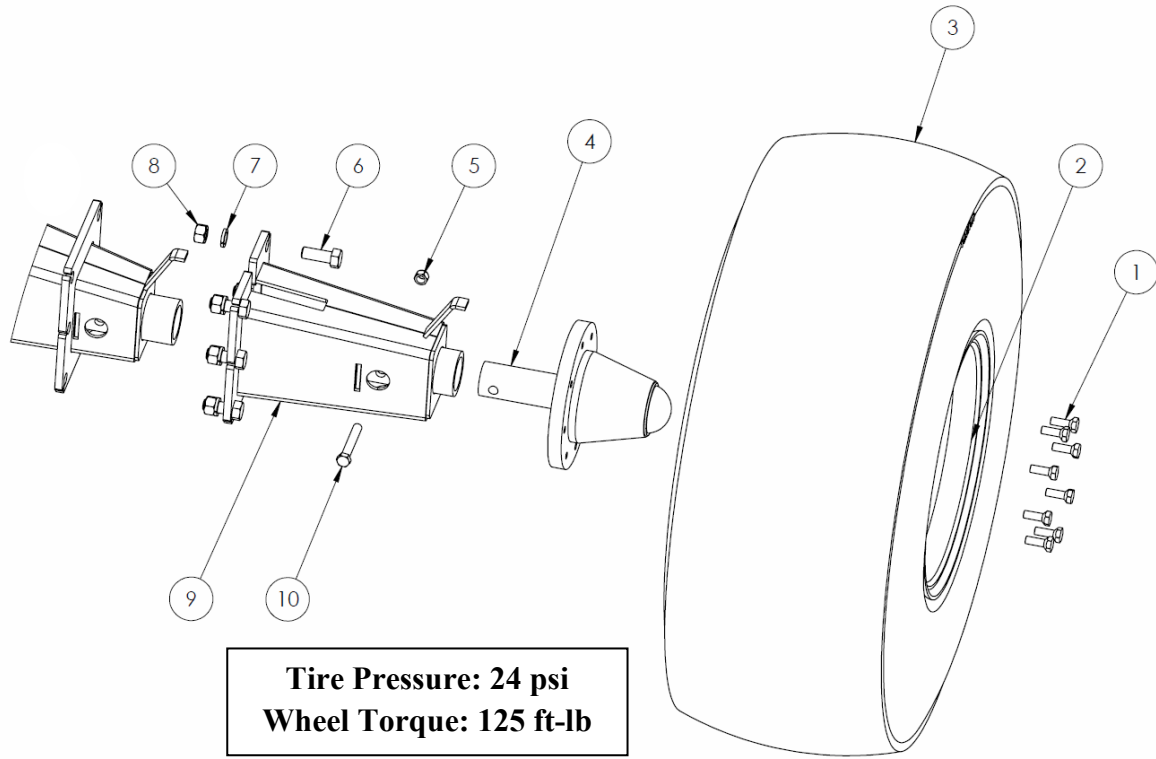

**Tire Pressure: 24 psi**  
**Wheel Torque: 125 ft-lb**

| #  | DESCRIPTION                  | PART #                            | QTY |
|----|------------------------------|-----------------------------------|-----|
| 1  | Wheel Stud, 9/16 x 1-3/4" NF | 10347                             | 16  |
| 2  | Rim, 16.1x14, 8 on 8"        | 10354                             | 2   |
| 3  | Tire, 16L-16.1 8 ply         | See your local tire dealer<br>NSS | 2   |
| 4  | Hub & Spindle Assembly       | See breakdown<br>29679            | 2   |
| 5  | Stover Lock Nut, 9/16"       | 21165                             | 2   |
| 6  | Bolt, 3/4 x 2"               | 13800                             | 6   |
| 7  | Flat Washer, 3/4"            | 13717                             | 6   |
| 8  | Stover Lock Nut, 3/4"        | 11823                             | 6   |
| 9  | Axle Extension               | 30259                             | 1   |
| 10 | Bolt, 9/16 x 4"              | 33912                             | 2   |

## Hub & Spindle

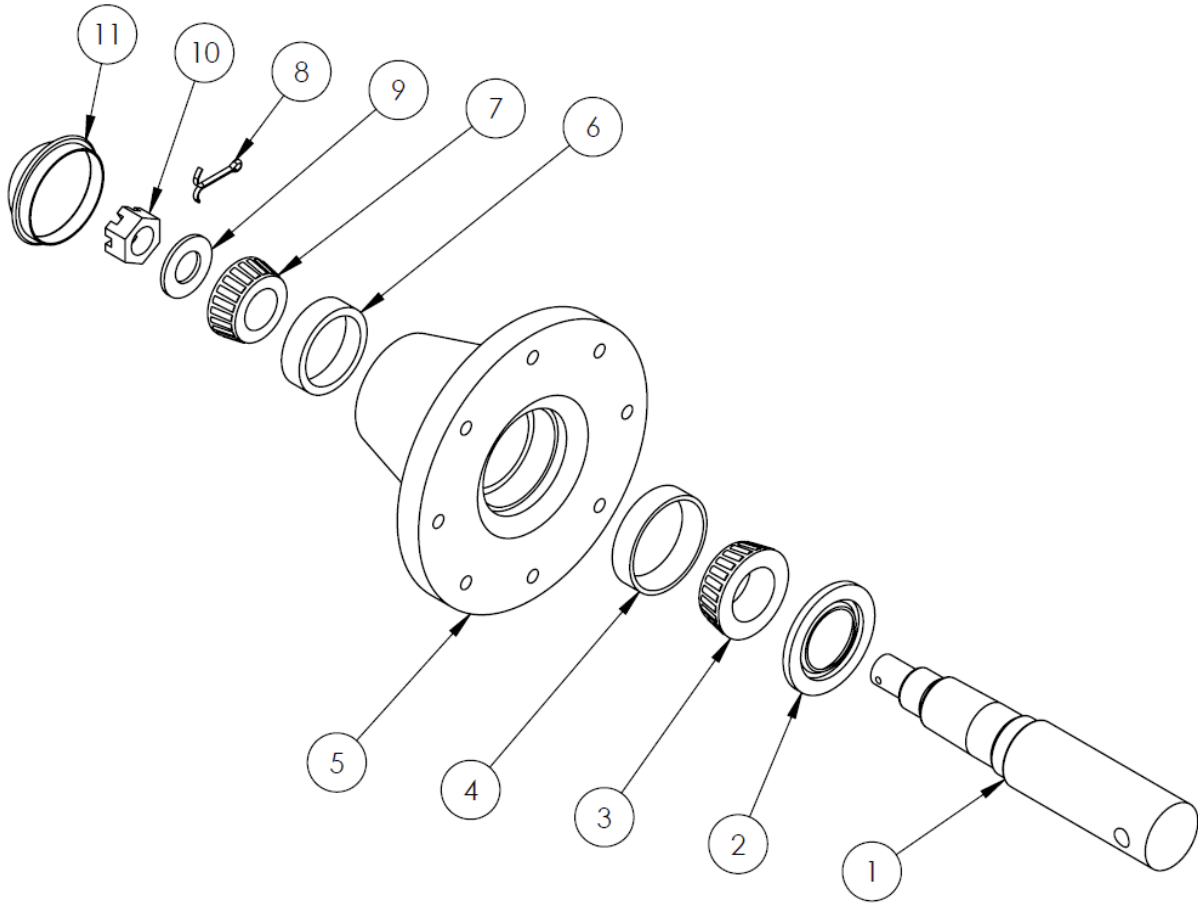

| #  | DESCRIPTION                    | PART #           | QTY   |   |
|----|--------------------------------|------------------|-------|---|
|    | Complete Assembly              | 29679            | 1     |   |
| 1  | 6500lb Spindle                 | 29730            | 2     |   |
| 2  | Seal, 2" ID                    | 10344            | 2     |   |
| 3  | Inner Bearing Cone, 1.796" ID  | LM25590          | 10345 | 2 |
| 4  | Inner Bearing Race             | 25520            | 10349 | 2 |
| 5  | Hub Housing                    | Includes #4 & #6 | 10343 | 2 |
| 6  | Outer Bearing Race             | 25821            | 10346 | 2 |
| 7  | Outer Bearing Cone, 1-3/8" ID  | LM25877          | 10348 | 2 |
| 8  | Cotter Pin, 3/16" x 1-1/2"     |                  | 10072 | 2 |
| 9  | Flat Washer, 1-1/6" ID x 2" OD |                  | 10071 | 2 |
| 10 | Castle Nut, 1" NF              |                  | 10153 | 2 |
| 11 | Dust Cap                       |                  | 10350 | 2 |

## Rotor & Drive Components

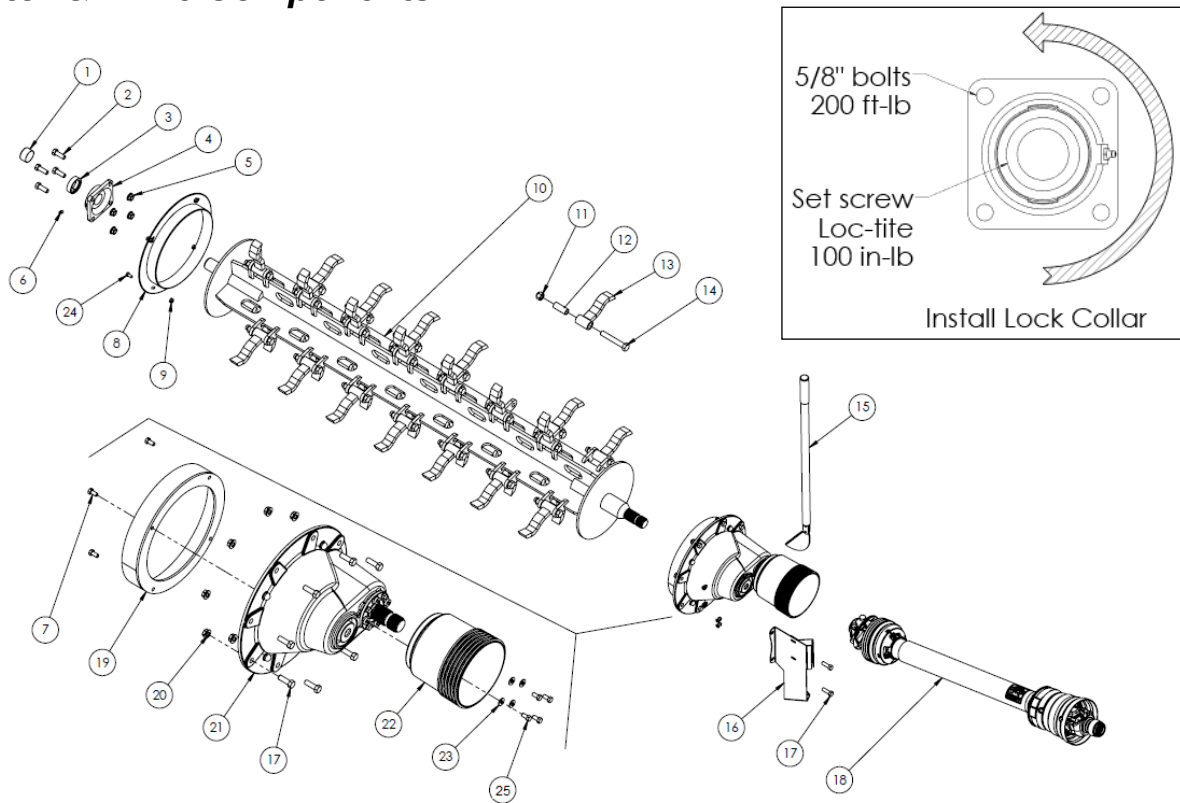

| #  | DESCRIPTION                        | PART #           | QTY   |   |
|----|------------------------------------|------------------|-------|---|
| 1  | Rotor Shaft Cap                    | 17380            | 1     |   |
| 2  | Bolt, 5/8" x 1-3/4" NF Gr. 8       | 10274            | 4     |   |
| 3  | Lock Collar                        | 10268            | 1     |   |
| 4  | Rotor Bearing                      | Includes # 3 & 6 | 10221 | 1 |
| 5  | Nut, 5/8" NF Serrated Flange Gr. 8 | 15398            | 4     |   |
| 6  | Grease Zerk, 1/8" NPT Straight     | 10270            | 1     |   |
| 7  | Bolt, 3/8" x 3/4"                  | 11816            | 4     |   |
| 8  | Rotor Twine Guard, Rear            | 22413            | 1     |   |
| 9  | Nut, 3/8" Serrated Flange          | 10271            | 4     |   |
| 10 | X-Rotor Weldment                   | 22449            | 1     |   |
| 11 | Nut, 3/4" Stover Lock              | 11823            | 28    |   |
| 12 | Brass Flail Bushing                | 10005            | 28    |   |
| 13 | Rotor Flail                        | 22412            | 28    |   |
| 14 | Bolt, 3/4" x 4-3/4"                | 10443            | 28    |   |
| 15 | OPTIONAL Twine Cutter              | See Breakdown    | -     |   |
| 16 | OPTIONAL Twine Cutter Holder       | See Breakdown    | -     |   |
| 17 | Bolt, 1/2" x 1-1/2"                | 10174            | 8     |   |
| 18 | PTO Shaft                          | See Breakdown    | 20546 | 1 |
| 19 | Gearbox Twine Guard                | 23002            | 1     |   |
| 20 | Nut, 1/2" Stover Lock              | 20154            | 8     |   |
| 21 | Gearbox Assembly                   | See Breakdown    | 22158 | 1 |
| 22 | PTO Safety Shield                  | 34899            | 1     |   |
| 23 | Flat Washer, 3/8"                  | 11667            | 4     |   |
| 24 | Bolt, 3/8 x 1"                     | 13806            | 4     |   |
| 25 | Bolt, M10 x 16                     | 25154            | 4     |   |

# Gearbox

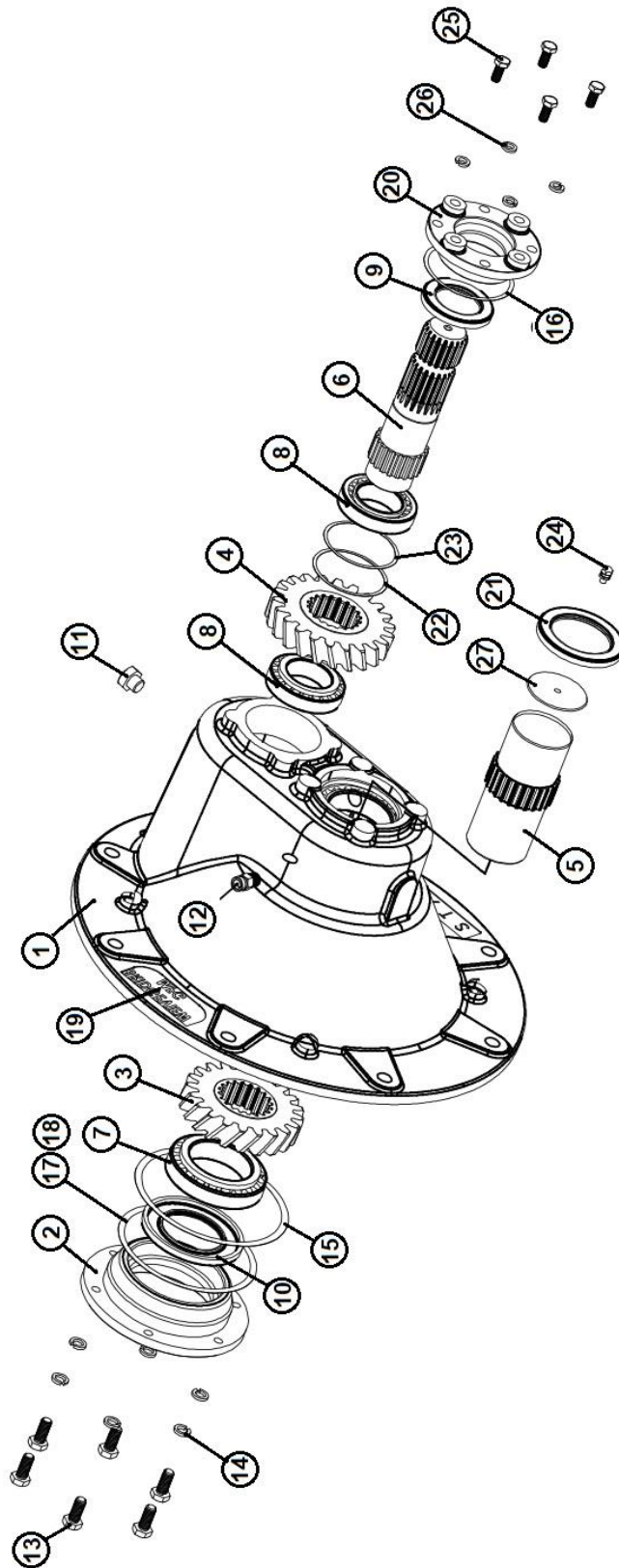

**Gearbox**

| #  | DESCRIPTION                   | PART # | QTY |
|----|-------------------------------|--------|-----|
|    | Complete Gearbox Assembly     | 22158  | 1   |
| 1  | Housing                       | NSS    | 1   |
| 2  | End Cap                       | NSS    | 1   |
| 3  | Output Gear                   | NSS    | 1   |
| 4  | Input Gear                    | NSS    | 1   |
| 5  | Output Shaft                  | NSS    | 1   |
| 6  | Input Shaft                   | NSS    | 1   |
| 7  | Bearing (32012) 60 mm         | 10496  | 2   |
| 8  | Bearing (32009) 45 mm         | 10497  | 2   |
| 9  | Seal, 45 x 60 x 8             | 24013  | 1   |
| 10 | Seal, 60 x 100 x 10           | 10498  | 1   |
| 11 | Pipe Plug, 3/8" NPT           | 24014  | 2   |
| 12 | Relief Plug, 3/8" NPT         | 24015  | 1   |
| 13 | Bolt, M8 x 25 Gr. 8.8         | 24026  | 6   |
| 14 | Lock Washer, M8               | 24016  | 6   |
| 15 | O-Ring                        | 24017  | 1   |
| 16 | O-Ring                        | 24018  | 1   |
| 17 | Shim, 125 x 164 x 0.1         | 24022  | 2   |
| 18 | Shim, 125 x 164 x 0.3         | 24023  | 2   |
| 19 | Name Plate (Bridgeview)       | NSS    | 1   |
| 20 | End Cap                       | NSS    | 1   |
| 21 | Seal, 60 x 85 x 10            | 10500  | 1   |
| 22 | Shim, 68 x 74.5 x 0.1         | 24024  | 2   |
| 23 | Shim, 68 x 74.5 x 0.3         | 24025  | 2   |
| 24 | Grease Zerk, 1/4"-28 Straight | 26219  | 1   |
| 25 | Bolt, M10 x 25                | 15087  | 4   |
| 26 | Lock Washer, M10              | 24021  | 4   |
| 27 | Press Cup                     | 24446  | 1   |

**NOTE:** Items with no part number are not sold separately. A complete gearbox is required.

## PTO Shaft

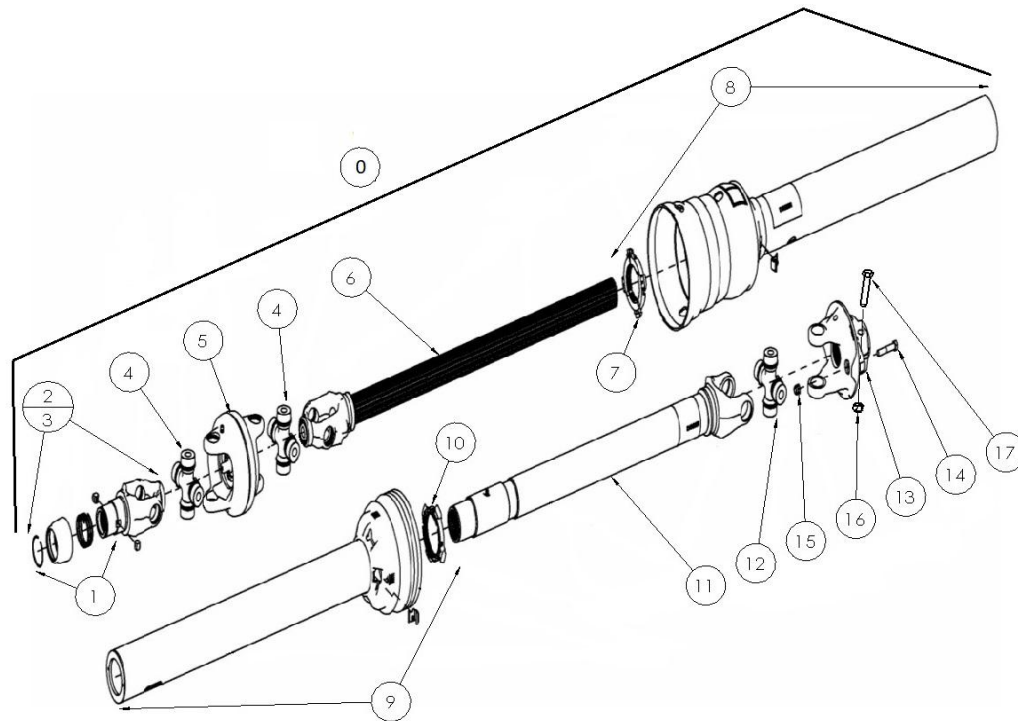

| #  | DESCRIPTION  | PART # | QTY |
|----|--|--------|-----|
|    | Complete PTO Shaft Assembly (1-3/8")                 | 20546  | 1   |
| 0a | Tractor Half PTO Assembly (1-3/8"-21 Spline)         | 32505  | 1   |
| 0b | Tractor Half PTO Assembly (1-3/4"-20 Spline)         | 32506  | 1   |
| 1a | Safety Slide Lock Repair Kit (1-3/8"-21 Spline)      | 17567  | 1   |
| 1b | Safety Slide Lock Repair Kit (1-3/4"-20 Spline)      | 24981  | 1   |
| 2  | WWCV Auto-Lok Yoke Assembly (1-3/8"-21 Spline)       | 20549  | 1   |
| 3  | WWCV Auto-Lok Yoke Assembly (1-3/4"-20 Spline)       | 20556  |     |
| 4  | CV Cross and Bearing Kit (Equal Length)              | 20550  | 2   |
| 5  | CV Center Housing                                    | 20551  | 1   |
| 6  | Yoke & Shaft Assembly Tractor Side                   | 20552  | 1   |
| 7  | Guard Repair Kit Tractor Side                        | 20553  | 1   |
| 8  | Guard Assembly Tractor Side                          | 17583  | 1   |
| 9  | Guard Assembly Implement Side                        | 17585  | 1   |
| 10 | Guard Repair Kit Implement Side                      | 17572  | 1   |
| 11 | Yoke & Tube Assembly Implement Side                  | 17584  | 1   |
| 12 | U-joint Cross & Bearing Kit                          | 17573  | 1   |
| 13 | Shear Assembly * Does not come with bolts 14 or 17 * | 29963  | 1   |
| 14 | Shear Bolt, 3/8" x 2" Fine Thread                    | 33285  | 1   |
| 15 | Nut, 3/8" Fine Thread Stover Lock                    | 33286  | 1   |
| 16 | Nut, 5/8" Stover Lock                                | 24982  | 2   |
| 17 | Bolt, 5/8" x 3-1/2"                                  | 24983  | 2   |

**NOTE:** Ensure that the PTO shaft on the machine is correct to the drawings below. Equal length CV cross (4.19") with bearing cup diameter 1.38". If the damaged PTO has different dimensions, consult the Bridgeview Manufacturing website.

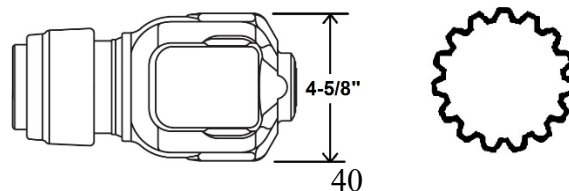

# Grates

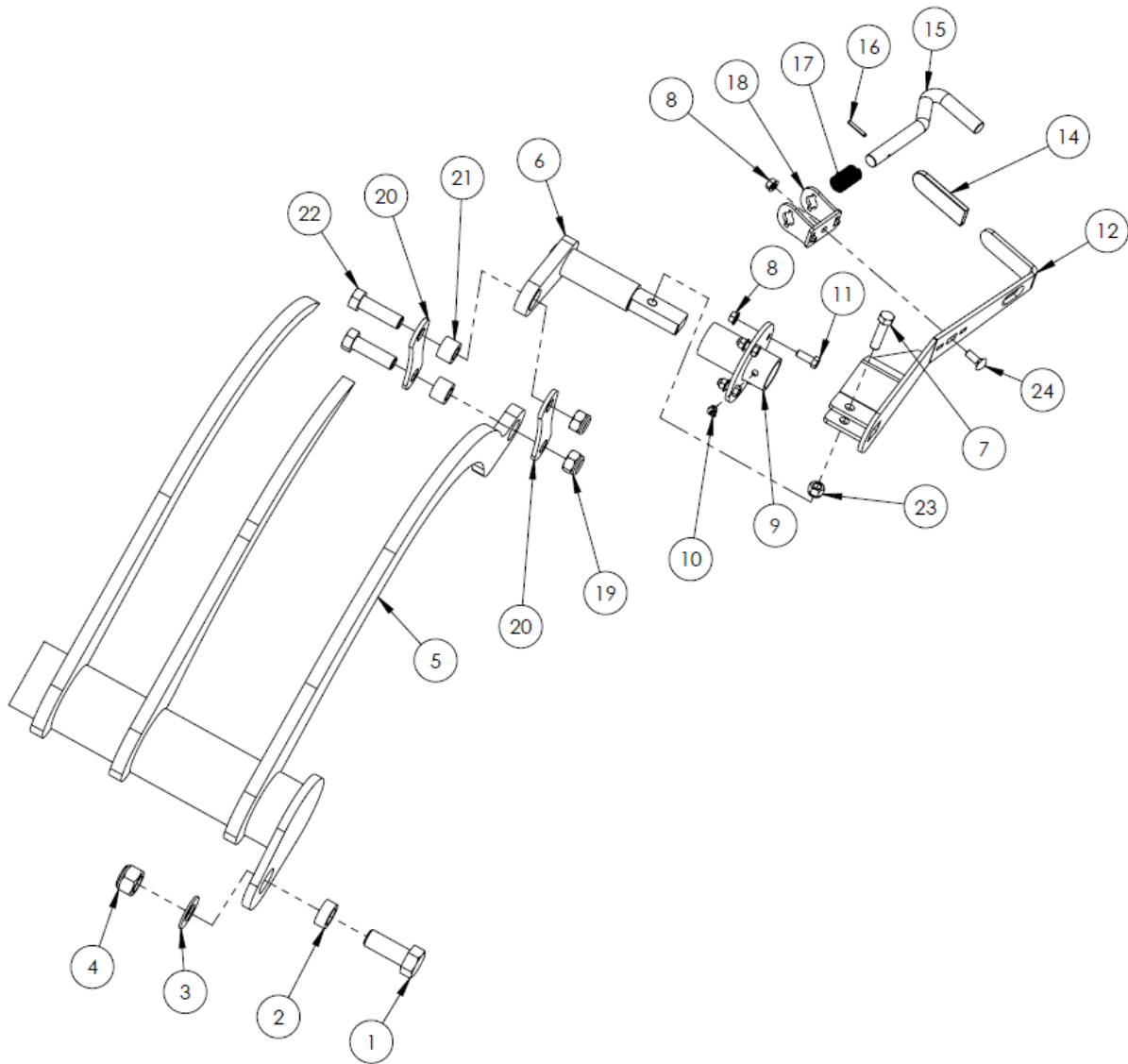

Grates

| #  | DESCRIPTION                | PART #              | QTY   |   |
|----|----------------------------|---------------------|-------|---|
| 1  | Bolt, 1" x 2-1/2"          | 21820               | 2     |   |
| 2  | Grate Pivot Bushing        | 22417               | 2     |   |
| 3  | Flat Washer, 1"            | 14472               | 2     |   |
| 4  | Nut, 1" Stover Lock        | 21746               | 2     |   |
| 5  | Grate Assembly             | 29944               | 1     |   |
| 6  | Grate Adjustment Cam       | Includes #9,10      | 31720 | 1 |
| 7  | Bolt, 1/2" x 2"            | 10322               | 1     |   |
| 8  | Nut, 3/8" Serrated Flange  | 10271               | 5     |   |
| 9  | Grate Handle Pivot         | NSS                 | 1     |   |
| 10 | Grease Zerk, 1/4"-28 x 45° | 20888               | 1     |   |
| 11 | Bolt, 3/8" x 1"            | 13806               | 4     |   |
| 12 | Grate Handle               | Comes with #18,24,8 | 31725 | 1 |
| 13 | Washer, 3/8" Flat          | 11667               | -     |   |
| 14 | Rubber Cover               | 10297               | 1     |   |
| 15 | S-Handle                   | 22187               | 1     |   |
| 16 | Roll Pin, 3/16" x 1-1/4"   | 10302               | 1     |   |
| 17 | Grate Handle Spring        | 10301               | 1     |   |
| 18 | Handle Spring Guide        | 33693               | 1     |   |
| 19 | Nut, 3/4" Stover Lock      | 11823               | 2     |   |
| 20 | Grate Shackle              | 31709               | 2     |   |
| 21 | Grate Shackle Bushing      | 22415               | 2     |   |
| 22 | Bolt, 3/4" x 2-1/4"        | 29824               | 2     |   |
| 23 | Nut, 1/2" Nylon Lock       | 10241               | 1     |   |
| 24 | Bolt, 3/8 x 1" Carriage    | 15718               | 1     |   |

## Rollers

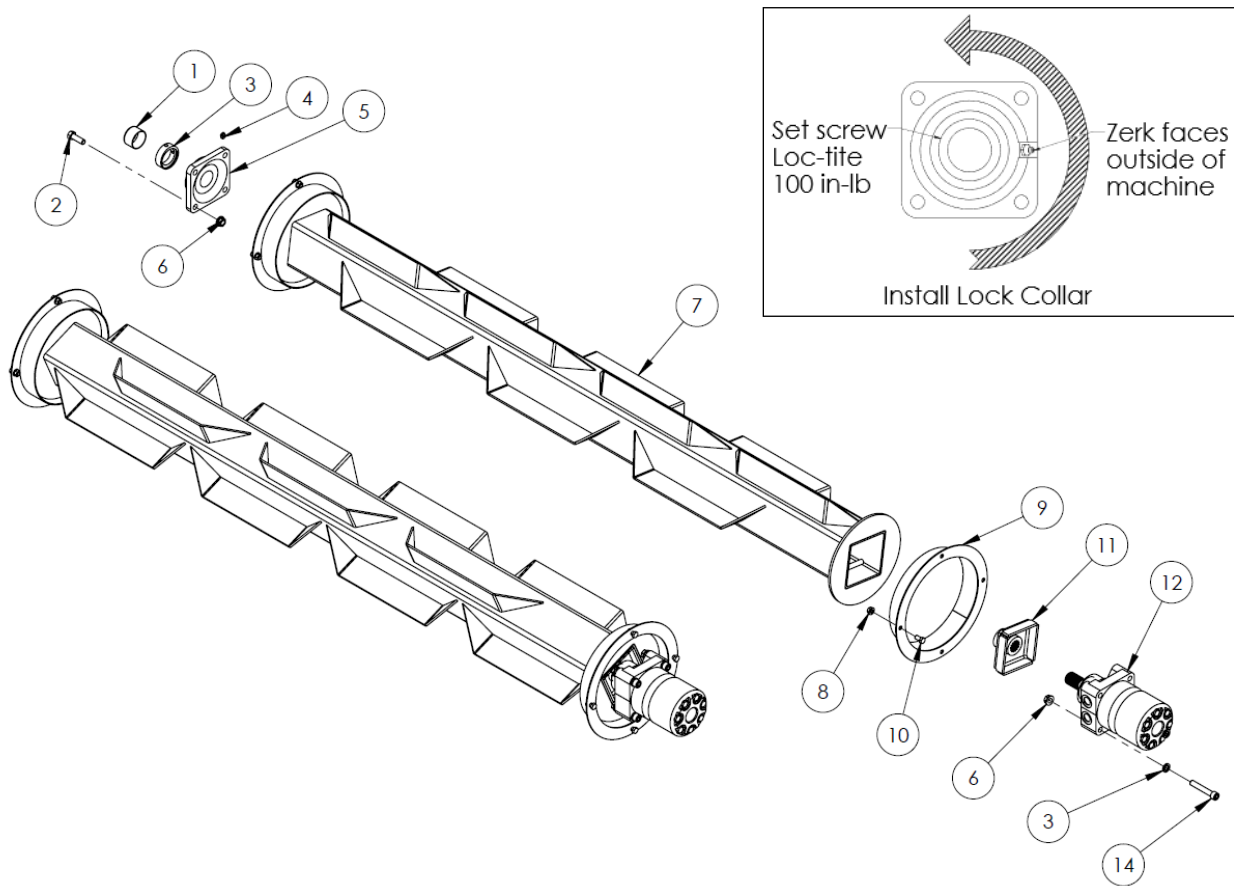

| #  | DESCRIPTION                    | PART #                                | QTY |
|----|--------------------------------|---------------------------------------|-----|
| 1  | Roller Shaft Cap               | 17381                                 | 2   |
| 2  | Bolt, 1/2" x 1-1/2"            | 10174                                 | 8   |
| 3  | Lock Collar                    | 10040                                 | 2   |
| 4  | Grease Zerk, 1/8" NPT Straight | 10270                                 | 2   |
| 5  | Roller Bearing                 | Includes # 3 & 4<br>10038             | 2   |
| 6  | Nut, 1/2" Serrated Flange      | 10273                                 | 16  |
| 7  | Roller                         | 31596                                 | 2   |
| 8  | Nut, 3/8" Serrated Flange      | All EXCEPT below<br>10271             | 14  |
|    | Nut, 3/8" Nylon Lock           | Rear Right (Wire Clip)<br>10806       | 1   |
|    | Nut, 5/16" Serrated Flange     | Front Right (Hydraulic Lock)<br>11814 | 1   |
| 9  | Roller Twine Guard             | 22419                                 | 4   |
| 10 | Bolt, 3/8" x 3/4"              | All EXCEPT below<br>11816             | 12  |
|    | Bolt, 3/8 x 1"                 | Front Left (Manual Holder)<br>13806   | 2   |
|    | Bolt, 3/8 x 1"                 | Rear Right (Wire Clip)<br>13806       | 1   |
|    | Nut, 5/16 x 2"                 | Front Right (Hydraulic Lock)<br>15572 | 1   |
| 11 | Roller Insert                  | 22084                                 | 2   |
| 12 | Roller Motor, 8" Long          | 25872                                 | 2   |
|    | * Seal Kit                     | 25891                                 |     |
| 13 | Lock Washer, 1/2"              | 14447                                 | 8   |
| 14 | Socket Head Bolt, 1/2" x 3"    | 25952                                 | 8   |

## Upper Tub Components

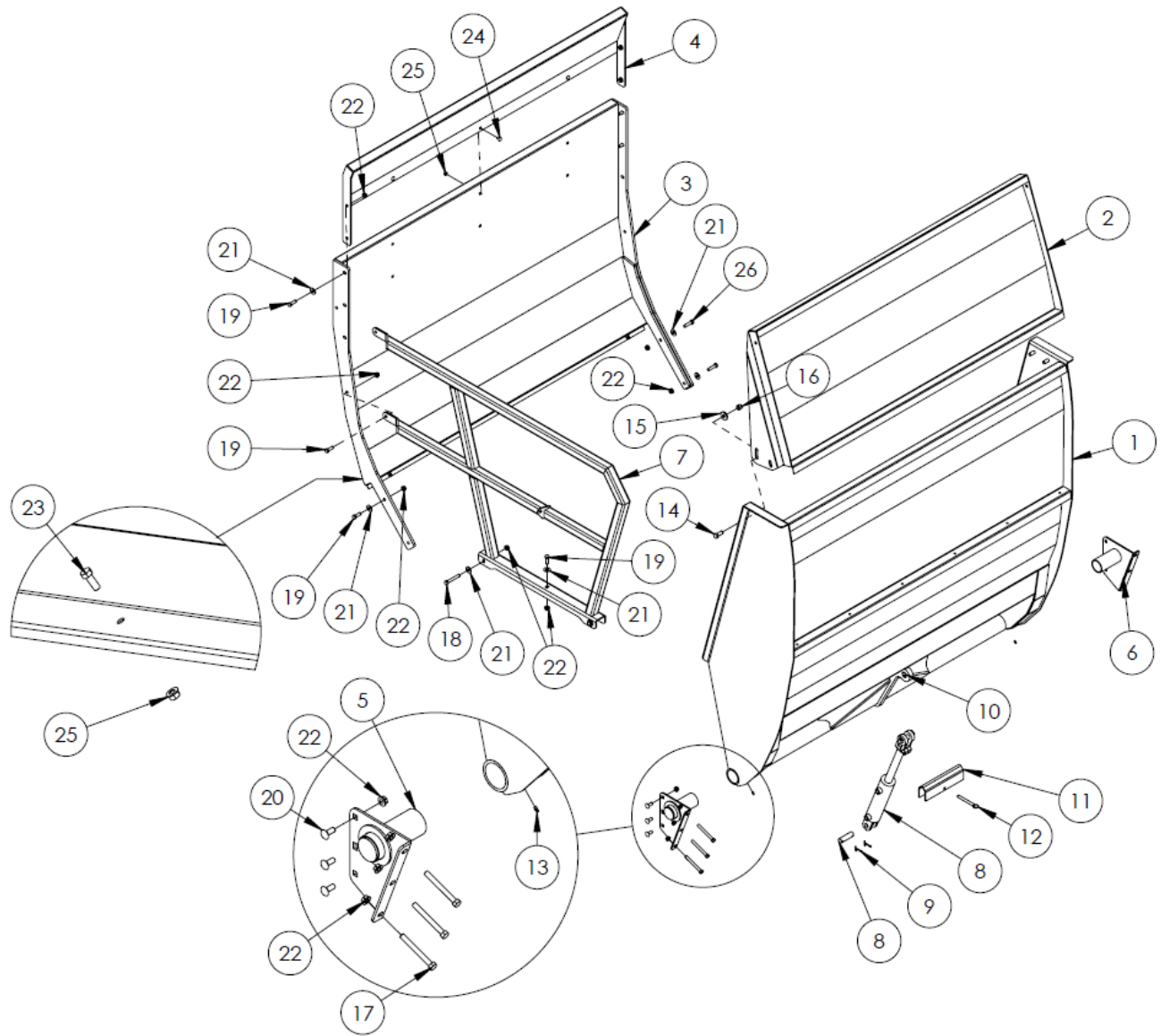

**Upper Tub Components**

| #  | DESCRIPTION   | PART #                 | QTY   |   |
|----|---|------------------------|-------|---|
| 1  | Pivoting Wing                                       | 35092                  | 1     |   |
| 2  | Optional Wing Extension Kit<br># Includes 14,15,16  | 35127                  | 1     |   |
| 3  | Fixed Wing  | 35094                  | 1     |   |
| 4  | Fixed Wing Extension                                | 35096                  | 1     |   |
| 5  | Front Wing Mount                                    | 24966                  | 1     |   |
| 6  | Rear Wing Mount                                     | 24967                  | 1     |   |
| 7  | Front Rack  | 35098                  | 1     |   |
| 8  | Hydraulic Cylinder<br>* Cylinder Pins<br>* Seal Kit | 2.5 x 8 x 1.5"         | 17443 | 1 |
|    |   | Included with cylinder | 10341 | 2 |
|    |   |                        | 17609 |   |
| 9  | Cotter Pin, 3/16 x 1-1/2"                           | 10072                  | 4     |   |
| 10 | Bushing Insert, 1"                                  | Included in #1         | 23708 | 2 |
| 11 | Wing Cylinder Lock                                  | 24973                  | 1     |   |
| 12 | 1/2" x 4" Quick Pin                                 | 21709                  | 1     |   |
| 13 | Grease Zerk 1/4"-28                                 | 16364                  | 2     |   |
| 14 | Bolt, 5/8 x 1-1/2"                                  | 10173                  | 4     |   |
| 15 | Washer, 5/8" Heavy Flat                             | 21390                  | 4     |   |
| 16 | Nut, 5/8" Nylon Lock                                | 10364                  | 4     |   |
| 17 | Bolt, 1/2 x 4-1/2"                                  | 15574                  | 6     |   |
| 18 | Bolt, 1/2 x 3-1/2"                                  | 10353                  | 2     |   |
| 19 | Bolt, 1/2 x 1-1/2"                                  | 10174                  | 9     |   |
| 20 | Bolt, 1/2 x 1-1/4" Carriage                         | 11819                  | 6     |   |
| 21 | Washer, 1/2" Flat                                   | 11668                  | 11    |   |
| 22 | Nut, 1/2" Serrated Flange                           | 10273                  | 25    |   |
| 23 | Bolt, 3/8 x 1"                                      | 13806                  | 4     |   |
| 24 | Bolt, 3/8 x 3/4" Carriage                           | 14072                  | 3     |   |
| 25 | Nut, 3/8" Serrated Flange                           | 10271                  | 7     |   |
| 26 | Bolt. 1/2 x 2"                                      | 10322                  | 2     |   |

## Rear Forks

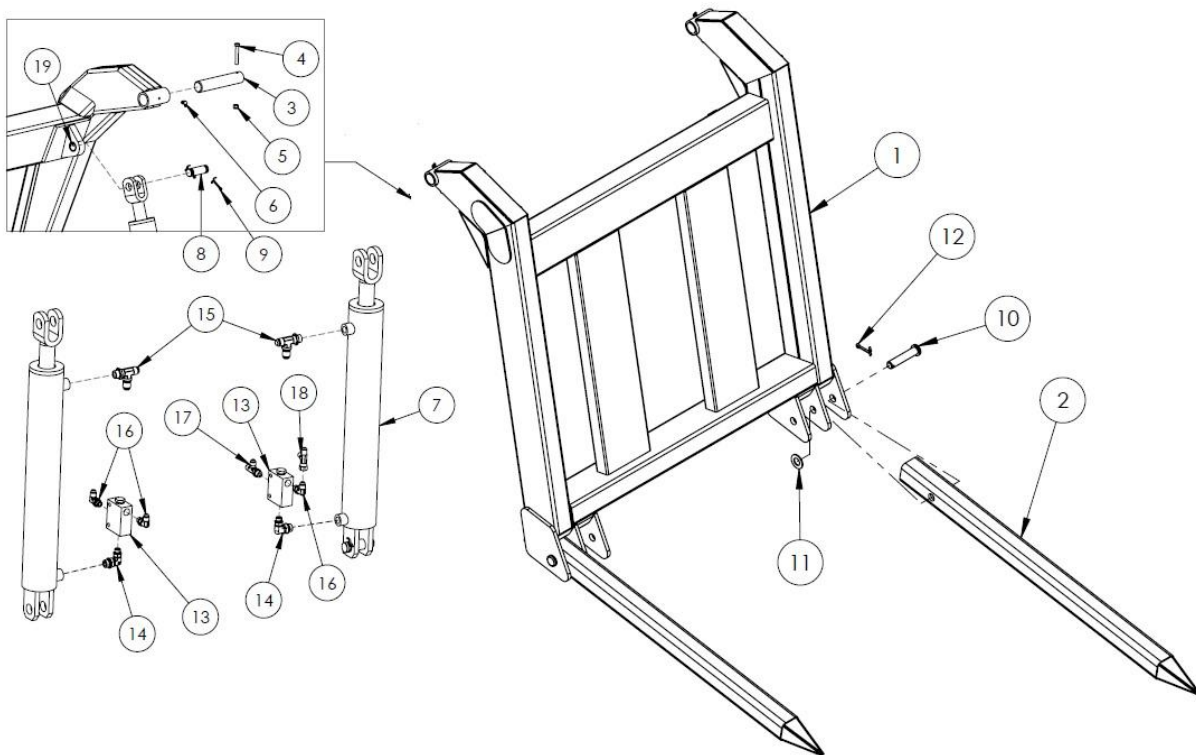

| #  | DESCRIPTION                                       | PART #   | QTY |
|----|---|--|-----|
| 1  | Rear Fork Frame                                   | 22420  | 1   |
| 2  | Fork Tine, 53"<br>Fork Tine, 48"                  | <i>S/N BK7695 &amp; above</i><br>36150<br><i>S/N BK7694 &amp; below</i><br>22421 | 2   |
| 3  | Rear Fork Pivot Pin                               | 22006  | 2   |
| 4  | Bolt, 3/8" x 2-3/4"                               | 20908  | 2   |
| 5  | Nut, 3/8" Nylon Lock                              | 10806  | 2   |
| 6  | Grease Zerk, 1/4" x 90°                           | 16389  | 2   |
| 7  | Hydraulic Cylinder, 3 x 18 x 1-1/2"<br>* Seal Kit | 21717<br>20807   | 2   |
| 8  | Cylinder Pin, 1 x 3-1/2"                          | 10339  | 4   |
| 9  | Cotter Pin, 3/16" x 1-1/2"                        | 10072  | 8   |
| 10 | Fork Tine Pin                                     | 10031  | 2   |
| 11 | Flat Washer, 1"                                   | 14472  | 2   |
| 12 | Cotter Pin, 1/4" x 2"                             | 10580  | 2   |
| 13 | Hydraulic Check Valve                             | 19114  | 2   |
| 14 | Hyd. Fitting, 8MB - 6MB90                         | 33739  | 2   |
| 15 | Hyd. Fitting, 8MBR - 8MJT                         | 22159  | 2   |
| 16 | Hyd. Fitting, 6MB - 6MJ90                         | 10201  | 3   |
| 17 | Hyd. Fitting, 6MBR - 6MJT                         | 23726  | 1   |
| 18 | Hyd. Fitting, 6FJXR - 6MJT                        | 15760  | 1   |
| 19 | Bushing Insert, 1"<br><i>Included in #1</i>       | 23708  | 4   |

## Deflector & Hose Cover

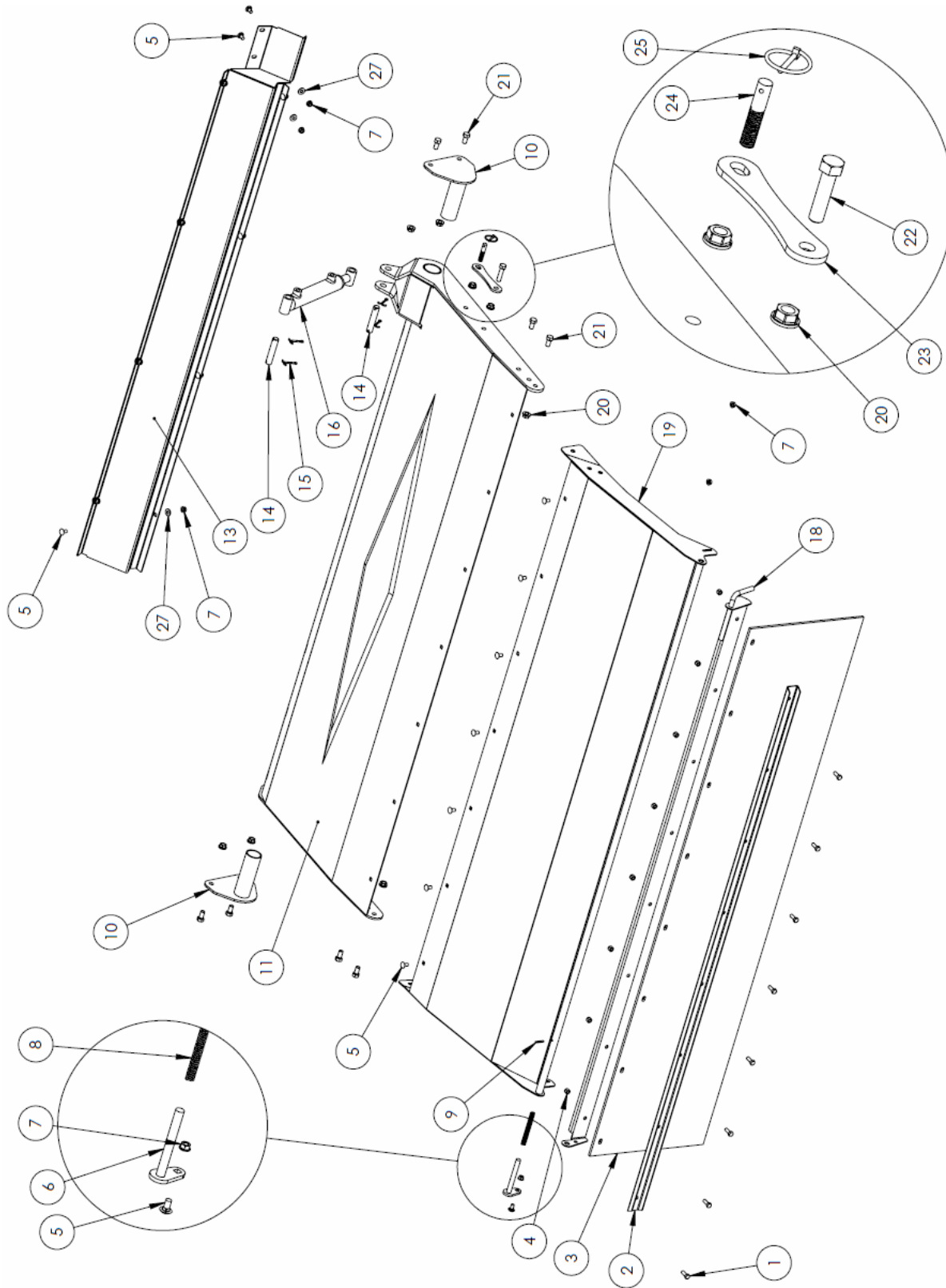

**Deflector & Hose Cover**

| #  | DESCRIPTION  | PART #         | QTY |
|----|--|----------------|-----|
| 1  | Bolt, 3/8" x 1"                                    | 13806          | 8   |
| 2  | Deflector Rubber Channel                           | 22423          | 1   |
| 3  | Deflector Rubber                                   | 10477          | 1   |
| 4  | Nut, 3/8" Nylon Lock                               | 10806          | 8   |
| 5  | Carriage Bolt, 3/8" x 3/4"                         | 14072          | 18  |
| 6  | Deflector Flipper Pin                              | 24464          | 1   |
| 7  | Nut, 3/8" Serrated Flange                          | 10271          | 18  |
| 8  | Compression Spring                                 | 24461          | 1   |
| 9  | Roll Pin, 3/16" x 1-1/4"                           | 10302          | 1   |
| 10 | Deflector Pivot                                    | 22426          | 2   |
| 11 | Inner Deflector                                    | 32196          | 1   |
| 13 | Hose Cover   | 32191          | 1   |
| 14 | Cylinder Pin, 3/4" x 3" Usable                     | 22007          | 2   |
| 15 | Cotter Pin, 3/16" x 1-1/4"                         | 11669          | 4   |
| 16 | Hydraulic Cylinder, 1-1/2" x 6" x 1"<br>* Seal Kit | 21711<br>23738 | 1   |
| 18 | Deflector Rubber Flipper                           | 24463          | 1   |
| 19 | Outer Deflector                                    | 31754          | 1   |
| 20 | Nut, 1/2" Serrated Flange                          | 10273          | 12  |
| 21 | Bolt, 1/2" x 1"                                    | 10824          | 8   |
| 22 | Bolt, 1/2" x 2"                                    | 10322          | 1   |
| 23 | Deflector Lock                                     | 22422          | 1   |
| 24 | Pin Stud   | 13231          | 1   |
| 25 | Lynch Pin  | 13233          | 1   |
| 27 | Flat Washer, 3/8"                                  | 11667          | 10  |

# Main Frame

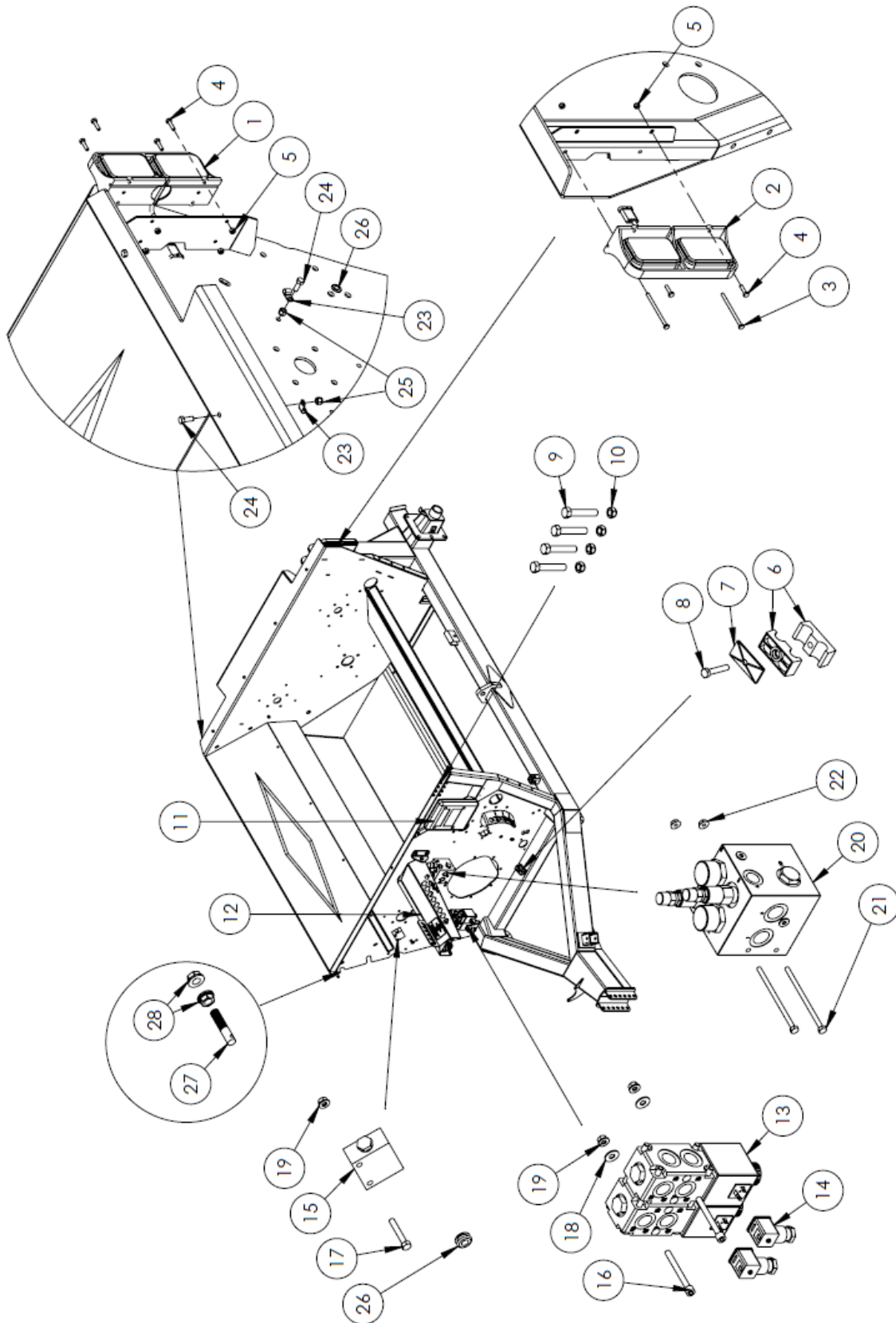

**Main Frame**

| #  | DESCRIPTION  | PART #  | QTY    |
|----|--|---|--------|
| 1  | Dual Light Assembly, RH  | 31088   | 1      |
| 2  | Dual Light Assembly, LH  | 31087   | 1      |
| 3  | Bolt, 1/4 x 4"   | 21734   | 2      |
| 4  | Bolt, 1/4 x 1"   | 11810   | 6      |
| 5  | Nut, 1/4" Nylon Lock   | 11664   | 8      |
| 6  | Hydraulic Hose Clamp   | 22180   | 1      |
| 7  | Hydraulic Hose Clamp Cap   | 21725   | 1      |
| 8  | Bolt, 5/16" x 1-3/4"   | 21726   | 1      |
| 9  | Shear Bolt, 3/8" x 2" NF Gr. 5 Bolt  | 33285   | 4      |
| 10 | 3/8" NF Stover Nut   | 33286   | 4      |
| 11 | Operator Manual Holder   | <i>*See breakdown*</i>                              | 1      |
| 12 | PTO/Hose Holder  | <i>*See breakdown*</i>                              | 1      |
| 13 | Diverter Valve<br>* Double Stack Kit<br>* Nut & O-Ring Kit<br>* Magnet Kit | 11743<br>12895<br>17977<br>11798                    | 2      |
| 14 | Valve Plug   | 13657   | 2      |
| 15 | Pilot Operated Check Valve   | 19114   | 1      |
| 16 | 5/16 x 3" Socket Head Bolt   | 11783   | 2      |
| 17 | 5/16 x 2" Bolt   | 15572   | 2      |
| 18 | 5/16" Flat Washer  | 12496   | 2      |
| 19 | 5/16" Nylon Lock Nut   | 11815   | 4      |
| 20 | Flow Divider Valve   | 25778   | 1      |
| 21 | Bolt, 5/16 x 5"<br>Bolt, 1/4 x 5"  | <i>BK7695 &amp; up</i><br><i>BK7694 &amp; below</i> | 3<br>2 |
| 22 | Nut, 5/16" Nylon Lock<br>Nut, 1/4" Nylon Lock                              | <i>BK7695 &amp; up</i><br><i>BK7694 &amp; below</i> | 3<br>2 |
| 23 | Wire Clamp   | 13629   | 5      |
| 24 | Bolt, 3/8 x 1"   | 13806   | 5      |
| 25 | Nut, 3/8" Nylon Lock   | 10806   | 5      |
| 26 | Grommet  | 21428   | 2      |
| 27 | Pin Stud   | 13231   | 1      |
| 28 | Nut, 1/2" Serrated Flange  | 10273   | 2      |

## Manual Holder

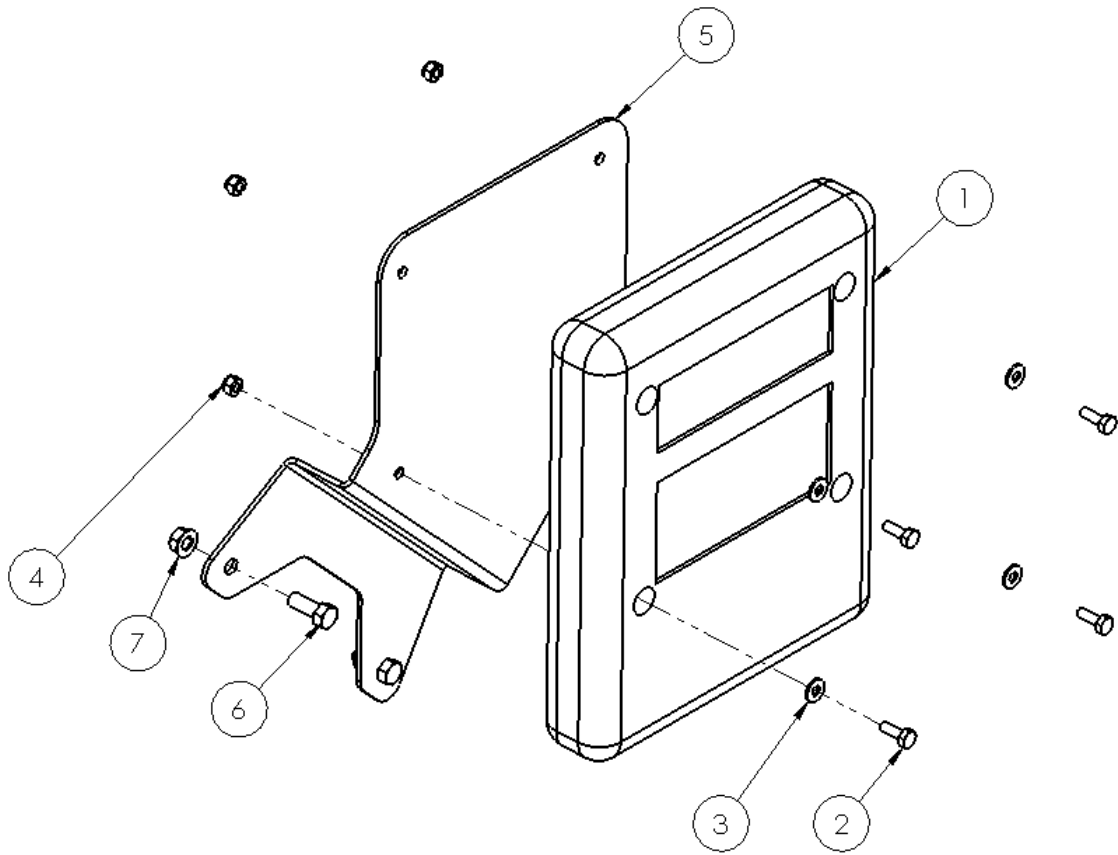

| # | DESCRIPTION              | PART # | QTY |
|---|--------------------------|--------|-----|
| 1 | Operator's Manual Cover  | 22409  | 1   |
| 2 | 1/4" x 3/4" Bolt         | 11809  | 4   |
| 3 | 1/4" Flat Washer         | 11666  | 4   |
| 4 | 1/4" Nylon Nut           | 11664  | 4   |
| 5 | Manual Cover Mount       | 24972  | 1   |
| 6 | 3/8" x 1" Bolt           | 13806  | 2   |
| 7 | 3/8" Serrated Flange Nut | 10271  | 2   |

## Hose Holder

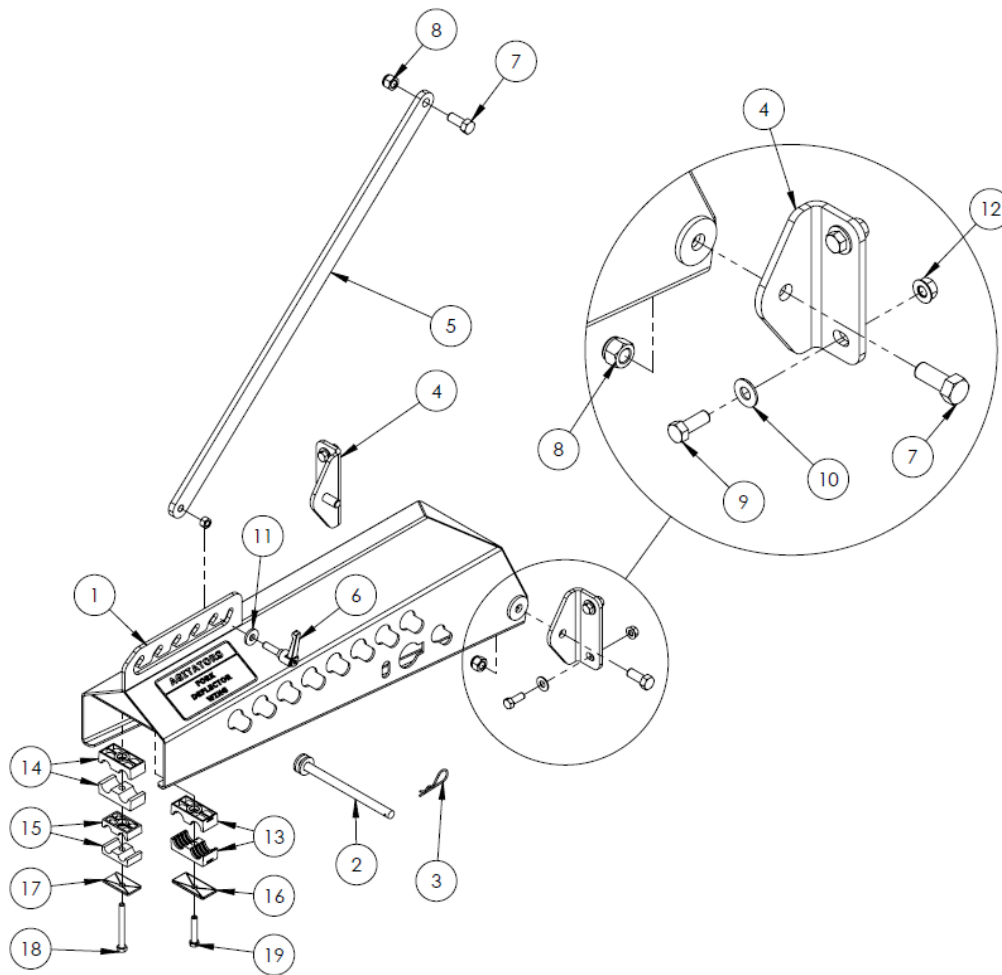

| #  | DESCRIPTION                     | PART # | QTY |
|----|---------------------------------|--------|-----|
| 1  | Adjustable Hose Holder          | 35038  | 1   |
| 2  | Hose Holder Pin                 | 31745  | 1   |
| 3  | Hairpin, 3/32 x 5/8"            | 11786  | 1   |
| 4  | Hose Holder Pivot Bracket       | 35041  | 2   |
| 5  | Hose Holder Linkage             | 35040  | 1   |
| 6  | Threaded Adjustable Handle      | 34944  | 1   |
| 7  | Bolt, 1/2 x 1-1/4"              | 10240  | 3   |
| 8  | Nut, 1/2" Nylon Lock            | 10241  | 3   |
| 9  | Bolt, 3/8" x 1"                 | 13806  | 4   |
| 10 | Flat Washer, 3/8"               | 11667  | 4   |
| 11 | Flat Washer, 3/8" Heavy         | 33189  | 1   |
| 12 | Nut, 3/8" Serrated Flange       | 10271  | 4   |
| 13 | Hydraulic Hose Clamp, 1/2"      | 21561  | 2   |
| 14 | Hydraulic Hose Clamp, 3/8"      | 22180  | 2   |
| 15 | Hydraulic Hose Clamp, 1/4"      | 22181  | 2   |
| 16 | Hydraulic Hose Clamp Cap, Large | 21725  | 1   |
| 17 | Hydraulic Hose Clamp Cap, Small | 22182  | 1   |
| 18 | Bolt, 5/16" x 3"                | 22844  | 1   |
| 19 | Bolt, 5/16" x 1-3/4"            | 21726  | 1   |

## Lights & Harness

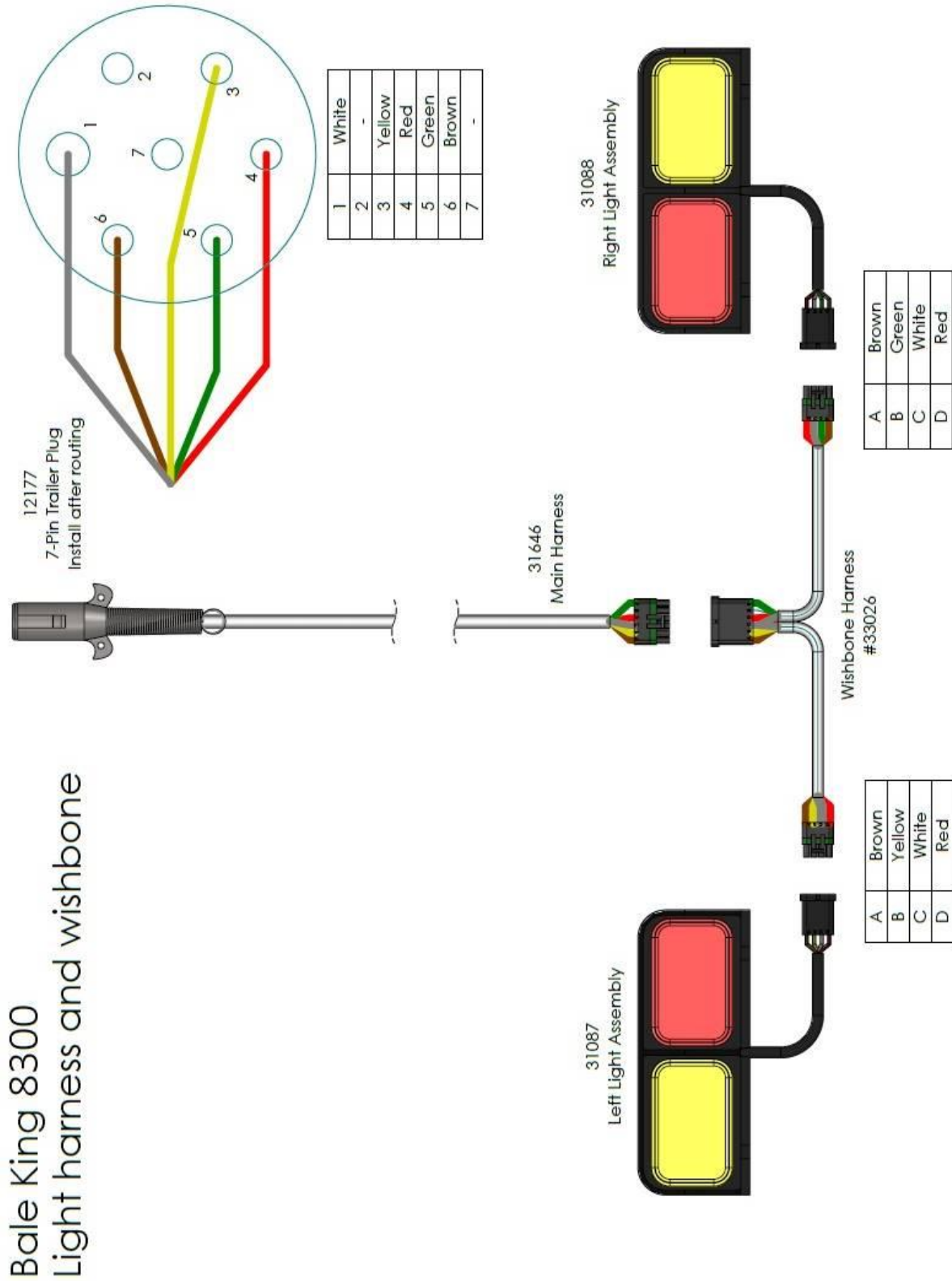

### Twine Cutter (Option)

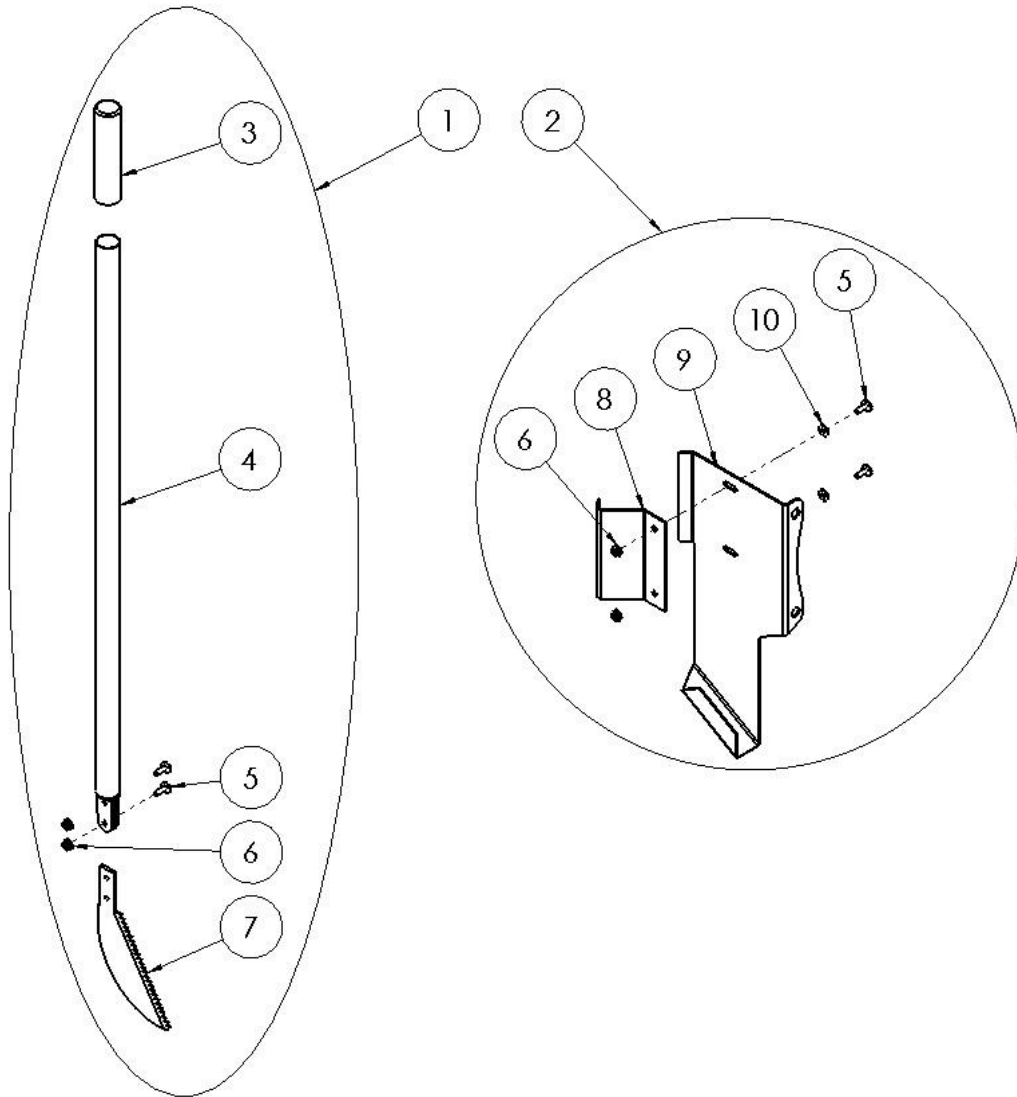

| #  | DESCRIPTION                         | PART #       | QTY |
|----|-------------------------------------|--------------|-----|
|    | <b>Twine Cutter Kit</b>             | <b>17686</b> | 1   |
| 1  | Twine Cutter Handle Kit             | -            | 1   |
| 2  | Twine Cutter Holder Kit             | 21549        | 1   |
| 3  | Rubber Handle Cap                   | 17587        | 1   |
| 4  | Twine Cutter Handle                 | 20862        | 1   |
| 5  | Bolt, 1/4" x 3/4" Truss Head        | 17638        | 4   |
| 6  | Nut, 1/4" Serrated Flange           | 11812        | 4   |
| 7  | Twine Cutter Blade                  | 17438        | 1   |
| 8  | Twine Cutter Holder Inside Bracket  | 17690        | 1   |
| 9  | Twine Cutter Holder Outside Bracket | 17691        | 1   |
| 10 | Flat Washer, 1/4"                   | 13763        | 2   |

### Fine Chop Kit (Option)

Version 1

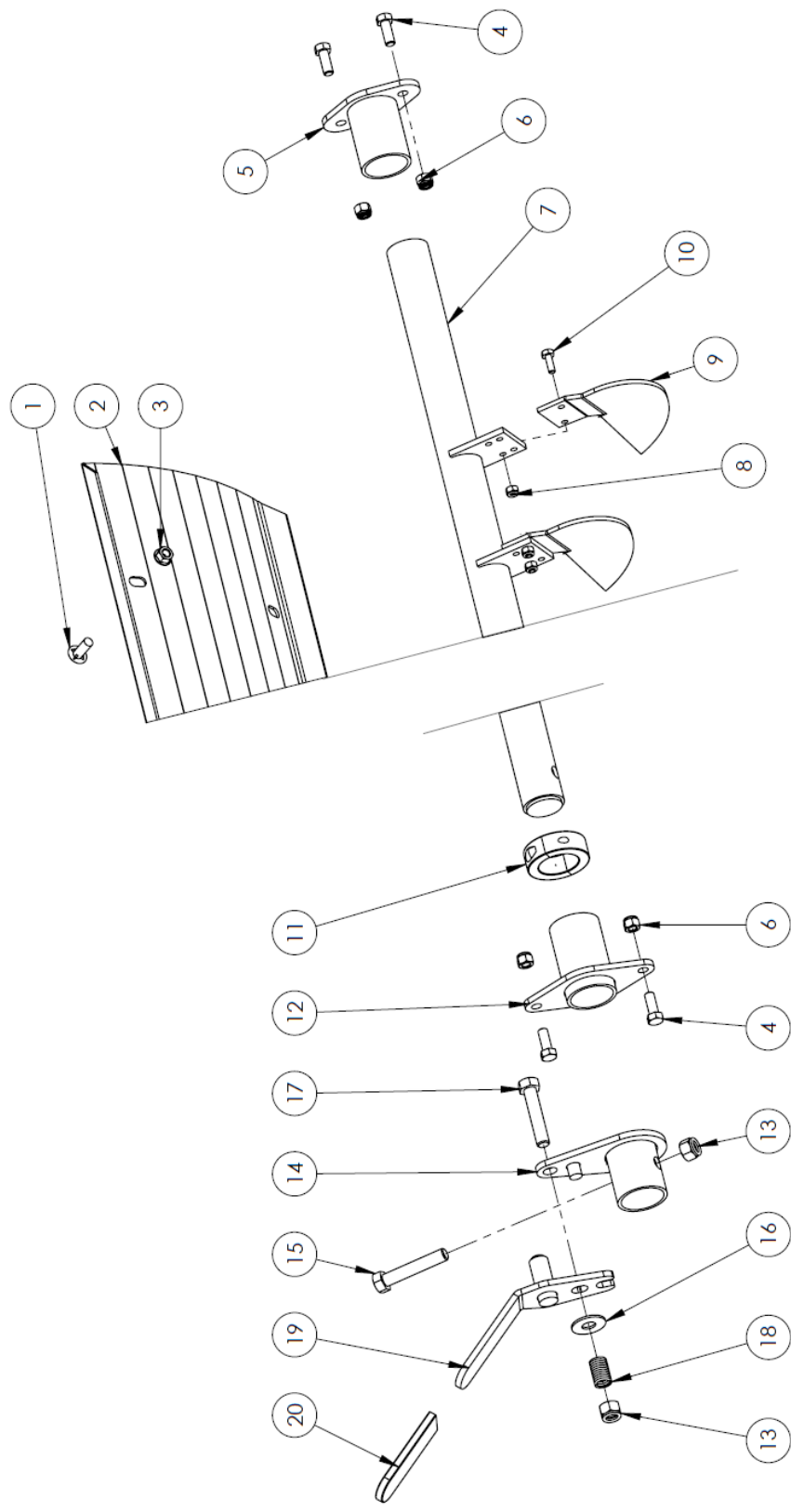

**Fine Chop Option – Version 1**

| #        | DESCRIPTION  | PART # | QTY |
|----------|--|--------|-----|
|          | <b>Fine Chop Cover</b> * IF NO FINE CHOP INSTALLED * |        |     |
| <b>1</b> | Fin Bolt, 3/8" x 3/4"                                | 10807  | 8   |
| <b>2</b> | Fine Chop Cover Plate                                | 22438  | 1   |
| <b>3</b> | Nut, 3/8" Serrated Flange                            | 10271  | 8   |

|           |                                   |       |    |
|-----------|-----------------------------------|-------|----|
|           | <b>Fine Chop Kit</b> * Optional * | 32117 | 1  |
| <b>4</b>  | Bolt, 3/8" x 1"                   | 13806 | 4  |
| <b>5</b>  | Fine Chop Mount                   | 22444 | 1  |
| <b>6</b>  | Nut, 3/8" Nylon Lock              | 10806 | 4  |
| <b>7</b>  | Fine Chop Bar                     | 32118 | 1  |
| <b>8</b>  | Nut, 1/4" Nylon Lock              | 11664 | 26 |
| <b>9</b>  | Fine Chop Blade                   | 10404 | 13 |
| <b>10</b> | Bolt, 1/4" x 3/4"                 | 11809 | 26 |
| <b>11</b> | Split Collar                      | 12792 | 1  |
| <b>12</b> | Fine Chop Front Mount             | 32122 | 1  |
| <b>13</b> | Nut, 1/2" Nylon Lock              | 10241 | 2  |
| <b>14</b> | Fine Chop Pivot                   | 32127 | 1  |
| <b>15</b> | Bolt, 1/2" x 2-3/4"               | 12378 | 1  |
| <b>16</b> | Flat Washer, 1/2"                 | 11668 | 1  |
| <b>17</b> | Bolt, 1/2" x 2-1/2"               | 10804 | 1  |
| <b>18</b> | Compression Spring                | 21713 | 1  |
| <b>19</b> | Fine Chop Handle                  | 32132 | 1  |
| <b>20</b> | Rubber Cover                      | 10297 | 1  |

### Fine Chop Kit (Option)

Version 2

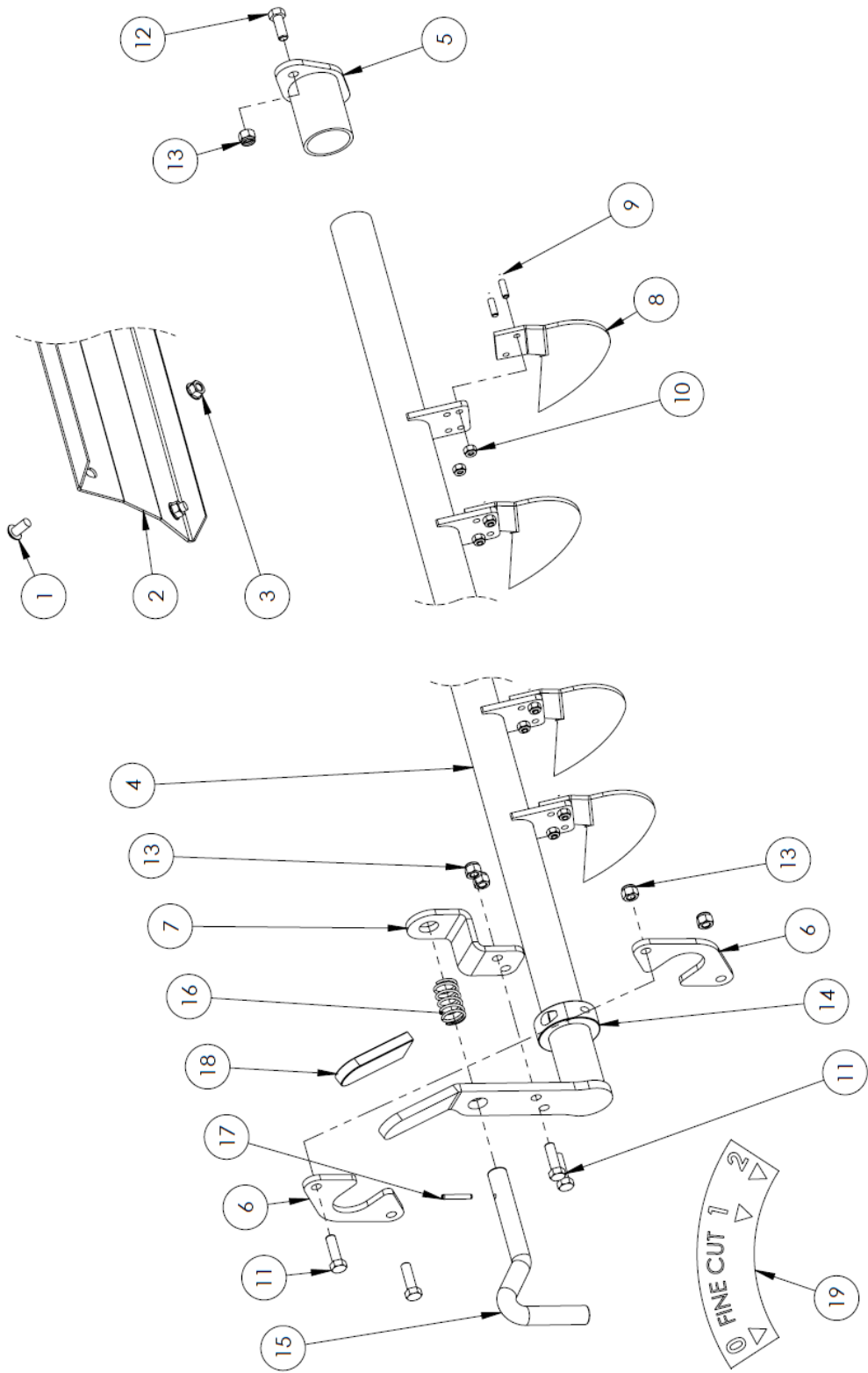

**Fine Chop Option – Version 2**

| #         | DESCRIPTION  | PART # | QTY |
|-----------|--|--------|-----|
|           | <b>Fine Chop Cover</b> * IF NO FINE CHOP INSTALLED * |        |     |
| <b>1</b>  | Fin Bolt, 3/8" x 3/4"                                | 10807  | 8   |
| <b>2</b>  | Fine Chop Cover Plate                                | 22438  | 1   |
| <b>3</b>  | Nut, 3/8" Serrated Flange                            | 11818  | 8   |
|           | <b>Fine Chop Kit</b> * Optional *                    | 36155  | 1   |
| <b>4</b>  | Fine Chop Bar  | 36164  | 1   |
| <b>5</b>  | Fine Chop Mount Rear                                 | 22444  | 1   |
| <b>6</b>  | Fine Chop Front Mount                                | 36163  | 2   |
| <b>7</b>  | Fine Chop Spring Mount                               | 36161  | 1   |
| <b>8</b>  | Fine Chop Knife                                      | 10404  | 13  |
| <b>9</b>  | Bolt, 1/4" x 3/4"                                    | 11809  | 26  |
| <b>10</b> | Nut, 1/4" Nylon Lock                                 | 11664  | 26  |
| <b>11</b> | Bolt, 3/8 x 1-1/4"                                   | 10253  | 4   |
| <b>12</b> | Bolt, 3/8" x 1"                                      | 13806  | 2   |
| <b>13</b> | Nut, 3/8" Nylon Lock                                 | 10806  | 6   |
| <b>14</b> | Split Collar   | 12792  | 1   |
| <b>15</b> | S-Handle   | 22187  | 1   |
| <b>16</b> | Compression Spring                                   | 34465  | 1   |
| <b>17</b> | Roll Pin, 3/16 x 1-1/4"                              | 10302  | 1   |
| <b>18</b> | Rubber Handle  | 10297  | 1   |
| <b>19</b> | Decal, Fine Chop                                     | 36031  | 1   |

## Back-up Camera Option

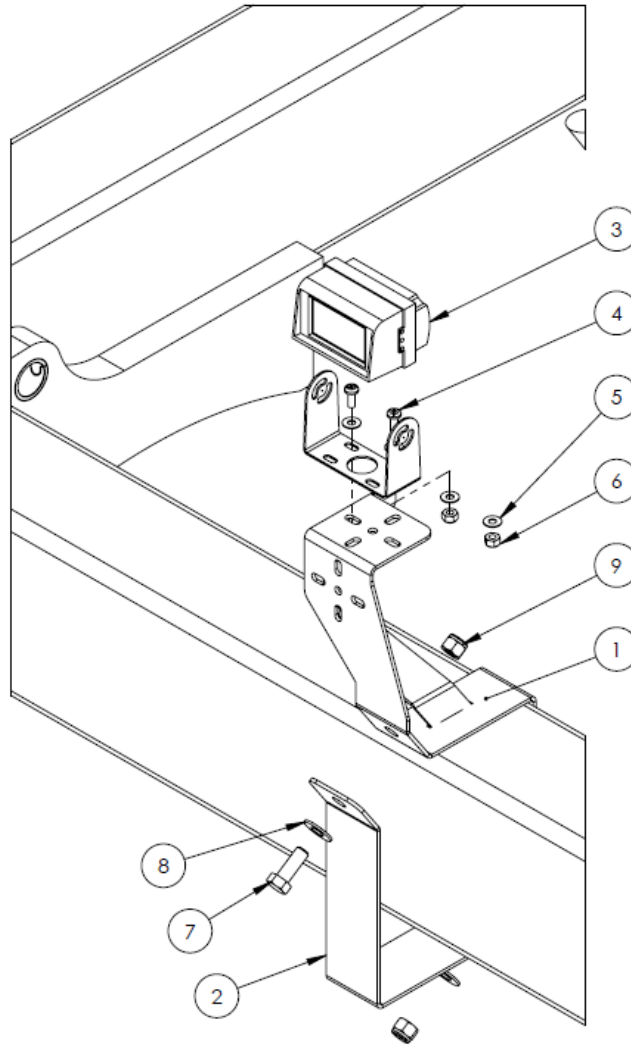

| #         | DESCRIPTION                                   | PART #       | QTY |
|-----------|---|--------------|-----|
|           | <b>Complete Back-up Camera Kit - Standard</b> | <b>32619</b> | -   |
|           | <b>Complete Back-up Camera Kit - Pro</b>      | <b>32628</b> | -   |
| <b>1</b>  | Camera Mounting Bracket                       | 32618        | 1   |
| <b>2</b>  | Camera Mounting Strap                         | 32617        | 1   |
| <b>3</b>  | * Back-up Camera – Standard                   | 32640        | 1   |
|           | * Back-up Camera – Pro                        | 32639        |     |
| <b>4</b>  | Bolt, #10 x 1/2"                              | 17035        | 2   |
| <b>5</b>  | Washer, #10 Flat                              | 25600        | 4   |
| <b>6</b>  | Nut, #10 Nylon Lock                           | 31110        | 2   |
| <b>7</b>  | Bolt, 3/8 x 1"                                | 13806        | 2   |
| <b>8</b>  | Washer, 3/8" Flat                             | 11667        | 4   |
| <b>9</b>  | Nut, 3/8" Nylon Lock                          | 10806        | 2   |
| <b>10</b> | Extension Cable, 15'                          | 32645        | 1   |
| <b>11</b> | Grommet, 5/16" ID x 1/4                       | 13179        | 2   |

**\*NOTE: Camera package comes with camera bracket, monitor, and harnesses**

## Diverter Valve

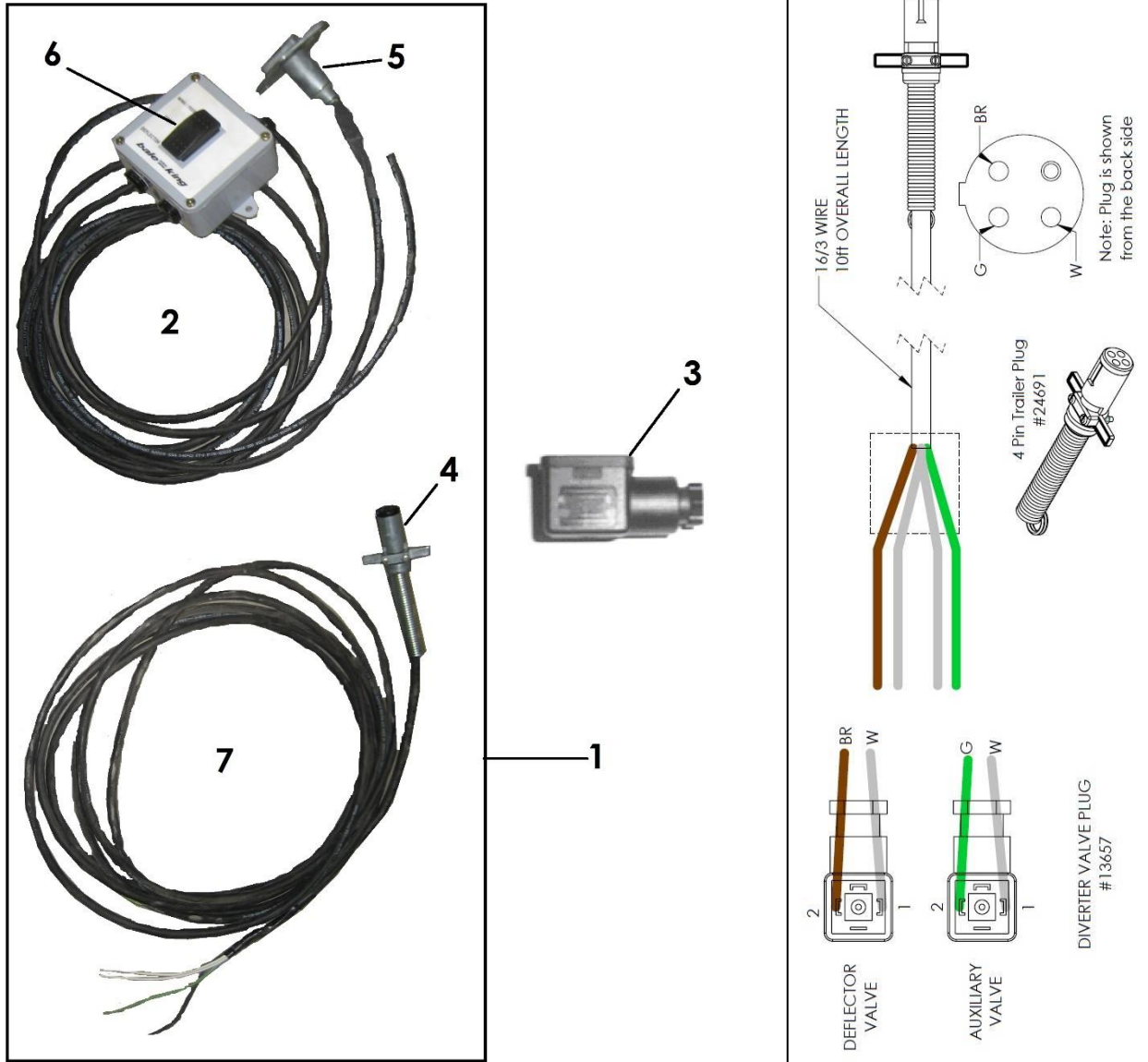

| # | DESCRIPTION  | PART # | QTY |
|---|--|--------|-----|
| 1 | Complete control box with harness for 8300 series              | 24466  | 1   |
| 2 | Control box complete with cab to hitch harness all 8300 series | NSS    | 1   |
| 3 | Square plug for diverter valve                                 | 13657  | 2   |
| 4 | 4-pin trailer plug   | 24691  | 1   |
| 5 | 4-pin tractor plug   | 24690  | 1   |
| 6 | 3 way switch   | 13561  | 1   |
| 7 | Harness (hitch to valve) 8300 series                           | 24693  | 1   |

### Diverter Control Box #24466

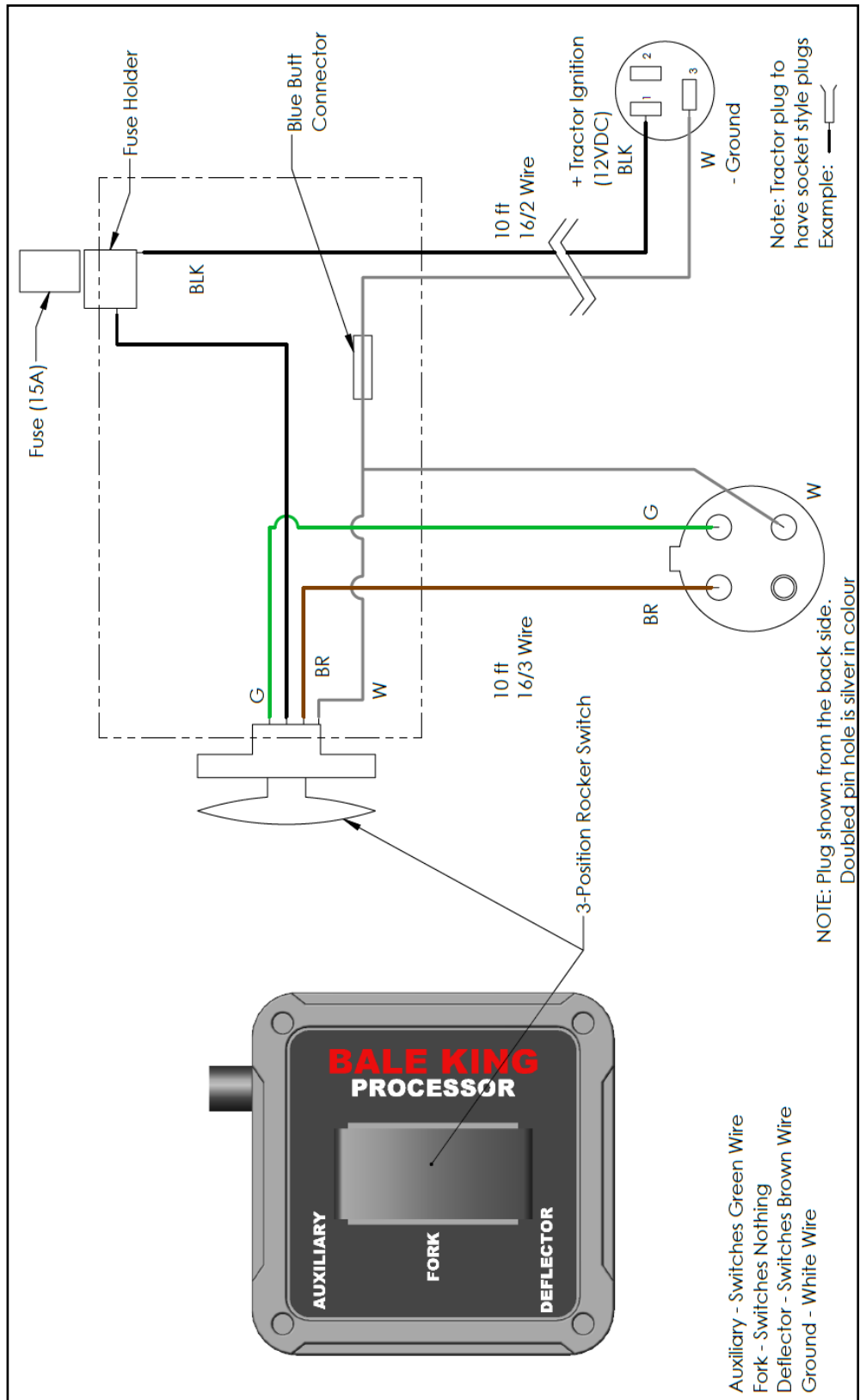

Decals



| #  | DESCRIPTION                  | PART # | QTY |
|----|------------------------------|--------|-----|
| 1  | “BALE KING”                  | 32804  | 2   |
|    | “8300”                       | 35076  | 2   |
| 2  | “DANGER” PTO                 | 12219  | 2   |
| 3  | “DANGER” Side Discharge      | 12230  | 4   |
| 4  | “DANGER” Stand Clear of Lift | 12229  | 1   |
| 5  | AMC Member                   | 12239  | 1   |
| 6  | FEMA Member                  | 25347  | 1   |
| 7  | Hoop Adjustment              | 31658  | 1   |
| 8  | Deflector Lock               | 22292  | 1   |
| 9  | Red Reflective               | 28383  | 1   |
| 10 | Amber Reflective             | 28384  | 4   |
| 11 | Wheel Torque Reminder        | 28385  | 2   |
| 12 | Speed Limit 20 mph           | 33159  | 1   |
| 13 | Hydraulic Decal              | 33144  | 1   |
| 14 | Slow Moving Vehicle Decal    | 12228  | 1   |

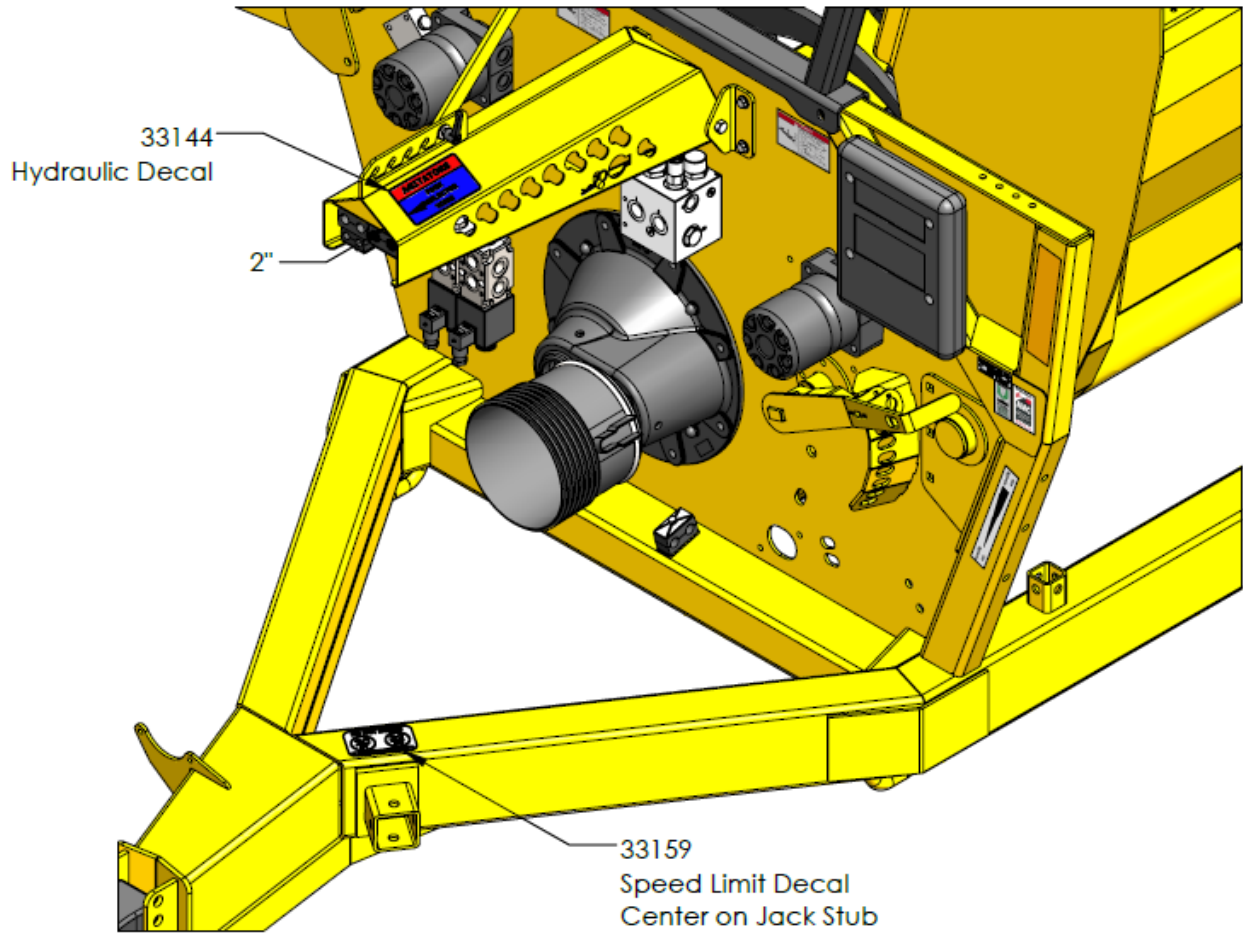
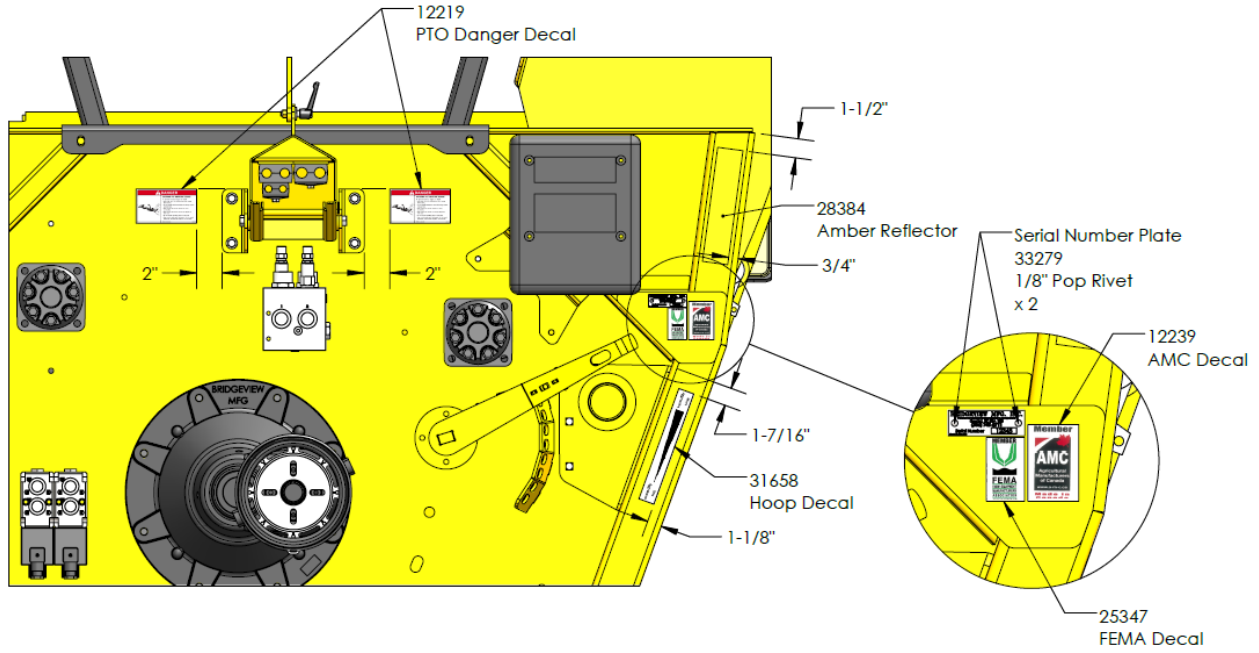

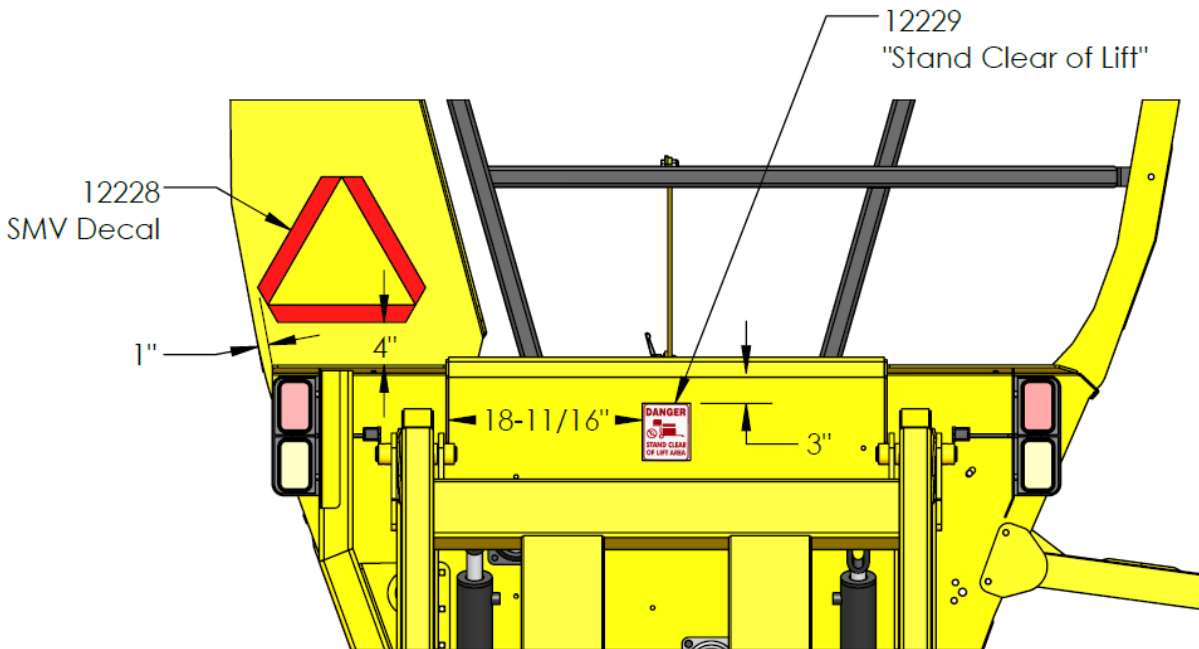
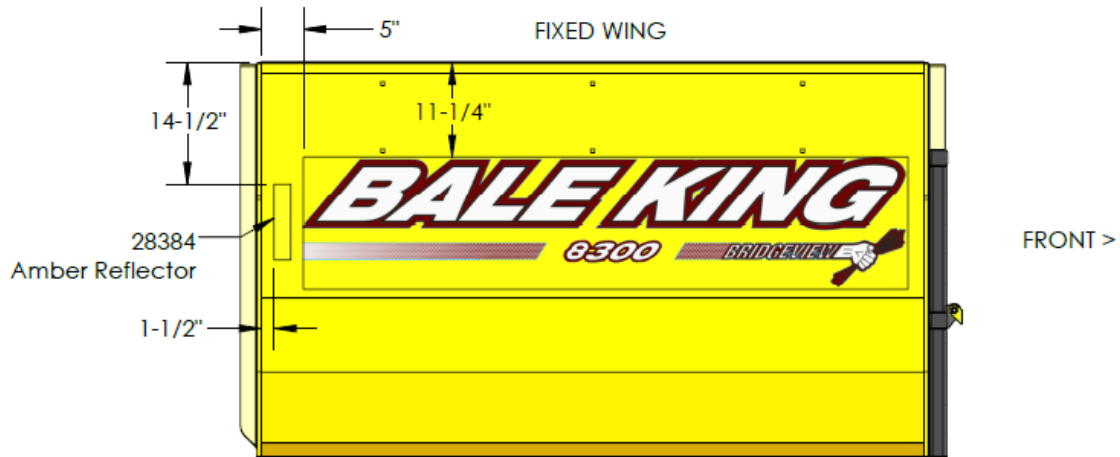
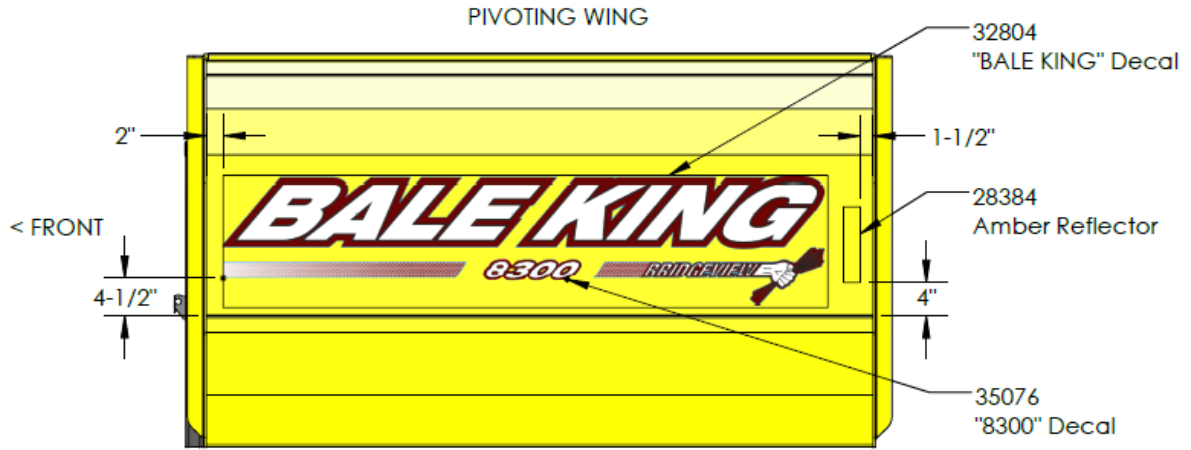

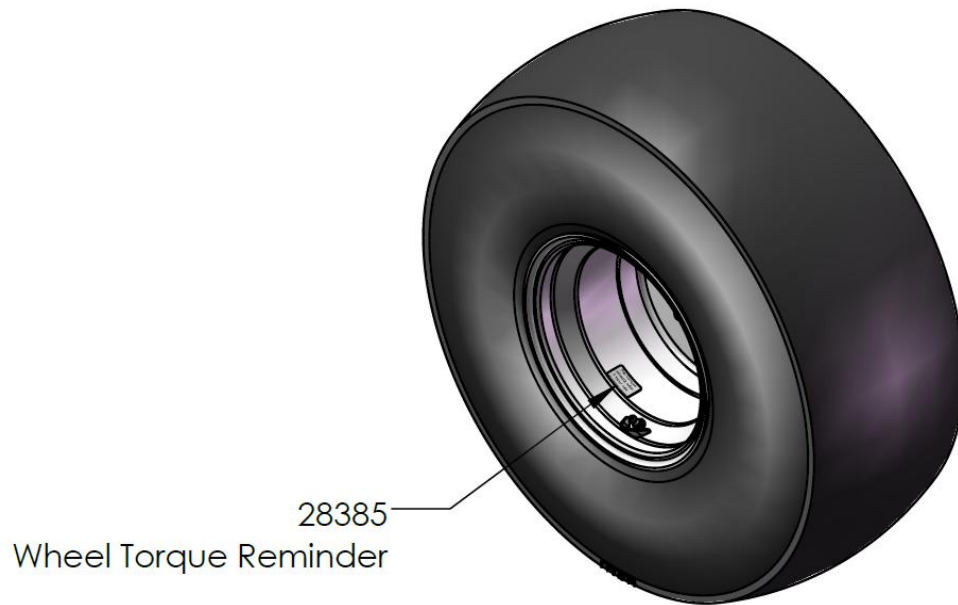
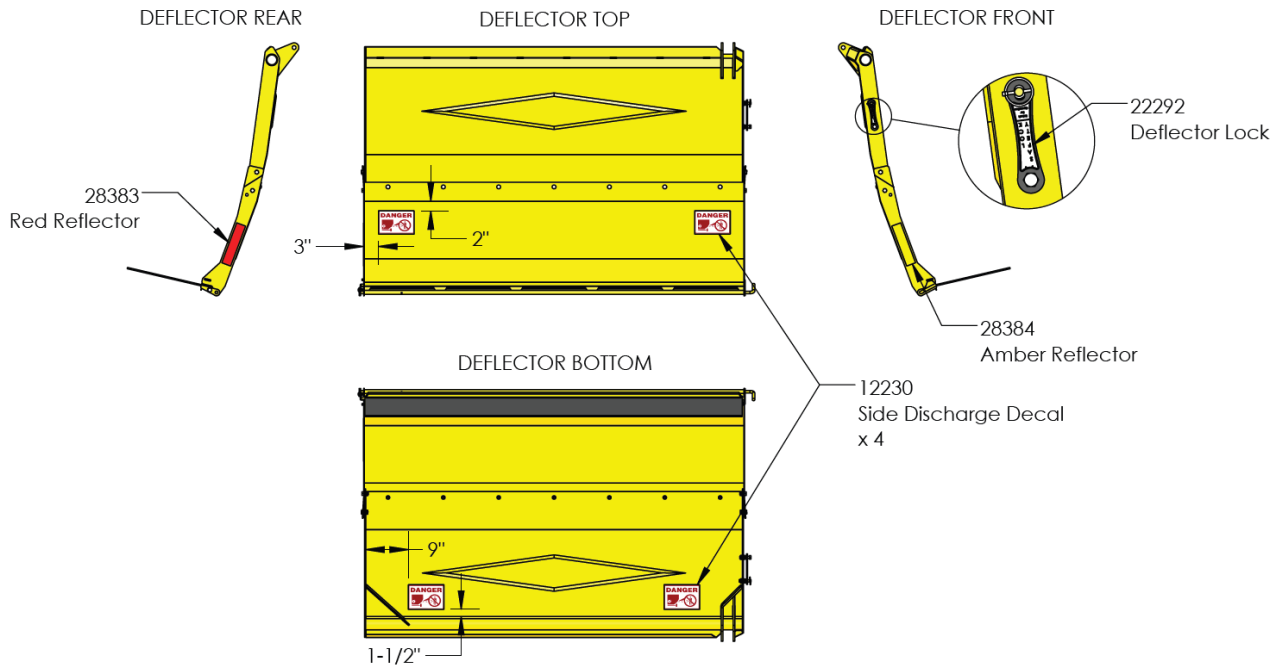

## Hydraulic Schematics

### Hydraulic Components

| #         | DESCRIPTION   |                       | PART #                           | QTY |
|-----------|---|-----------------------|----------------------------------|-----|
| <b>AA</b> | Hydraulic Cylinder – 3 x 18 x 1.5”<br>* Seal Kit<br>* Stopper Kit | Rear Forks            | 21717<br>20807<br>21860          | 2   |
| <b>BB</b> | Hydraulic Cylinder – 2.5 x 8 x 1.5”<br>* Seal Kit                 | Wing                  | 17443<br>17609                   | 1   |
| <b>CC</b> | Hydraulic Cylinder – 1.5 x 6 x 1”<br>* Seal Kit                   | Deflector             | 21711<br>23738                   | 1   |
| <b>DD</b> | Pilot-operated Check Valve  | Deflector, Rear Forks | 19114                            | 3   |
| <b>EE</b> | Diverter Valve<br>* Nut & O-Ring<br>* Magnet<br>* Stack Kit       |                       | 11743<br>17977<br>11789<br>12895 | 2   |
| <b>FF</b> | Hydraulic Motor<br>* Seal Kit                                     | Rollers               | 25872<br>25891                   | 2   |
| <b>GG</b> | Flow Divider Valve  | Rollers               | 25778                            | 1   |
| <b>HH</b> | Pioneer Tip, 8FB  |                       | 17379                            | 4   |
| <b>II</b> | Hose Marker, Long Red   | Rollers               | 20791                            | 1   |
| <b>JJ</b> | Hose Marker, Short Red  | Rollers               | 20790                            | 1   |
| <b>KK</b> | Hose Marker, Long Blue  | Diverter              | 34985                            | 1   |
| <b>LL</b> | Hose Marker, Short Blue   | Diverter              | 18497                            | 1   |

|          |                                  |  |       |    |
|----------|----------------------------------|--|-------|----|
| <b>A</b> | Adaptor, 12MB-8MJ90              |  | 22174 | 2  |
| <b>B</b> | Adaptor, 10MB-6MJ                |  | 11739 | 10 |
| <b>C</b> | Adaptor, 10MB-6MJ45              |  | 22722 | 6  |
| <b>D</b> | Adaptor, 8MB-8MJ                 |  | 10561 | 1  |
| <b>E</b> | Adaptor, 8MB-8MJ Orifice (1/32") |  | 10562 | 1  |
| <b>F</b> | Adaptor, 8MBR-8MJT               |  | 22159 | 2  |
| <b>G</b> | Adaptor, 8MB-6MB90               |  | 33739 | 2  |
| <b>H</b> | Adaptor, 6MB-6MJ                 |  | 10162 | 1  |
| <b>I</b> | Adaptor, 6MB-6MJ Orifice (1/32") |  | 17436 | 2  |
| <b>J</b> | Adaptor, 6MB-6MJ90               |  | 10201 | 4  |
| <b>K</b> | Adaptor, 6MB-6MJ45               |  | 10216 | 1  |
| <b>L</b> | Adaptor, 6MBR-6MJT               |  | 23726 | 1  |
| <b>M</b> | Adaptor, 6MJ-6MJBH90             |  | 10187 | 6  |
| <b>N</b> | Adaptor, 6FJXR-6MJT              |  | 15760 | 2  |
| <b>O</b> | Adaptor, 6MJ-6FJX90              |  | 12162 | 2  |

**Hydraulic Hoses**

| #  | DIAM. | LENGTH     | ENDS           | QTY |
|----|-------|------------|----------------|-----|
| 1  | 1/2"  | 98" OAL    | 8MB - 8FJX     | 2   |
| 2  | 3/8"  | 122" OAL   | 8MB - 6FJX     | 2   |
| 3  | 3/8"  | 17.25" OAL | 6FJX - 6FJX90  | 1   |
| 4  | 3/8"  | 13.5" OAL  | 6FJX - 6FJX    | 1   |
| 5  | 3/8"  | 11.25" OAL | 6FJX - 6FJX90  | 1   |
| 6  | 3/8"  | 8.5" OAL   | 6FJX - 6FJX    | 1   |
| 7  | 3/8"  | 58" OAL    | 6FJX - 6FJX    | 1   |
| 8  | 3/8"  | 29.5" OAL  | 8FJX - 8FJX    | 1   |
| 9  | 3/8"  | 30" OAL    | 6FJX - 6FJX    | 1   |
| 10 | 3/8"  | 25" OAL    | 6FJX - 6FJX45  | 1   |
| 11 | 3/8"  | 16" OAL    | 6FJX - 8FJX    | 1   |
| 12 | 3/8"  | 14.25" OAL | 6FJX - 8FJX    | 1   |
| 13 | 3/8"  | 79.5" OAL  | 6FJX - 6FJX    | 2   |
| 14 | 3/8"  | 48" OAL    | 6FJX - 8FJX90  | 1   |
| 15 | 3/8"  | 57" OAL    | 6FJX - 8FJX90  | 1   |
| 16 | 3/8"  | 45" OAL    | 6FJX - 6FJX90  | 2   |
| 17 | 3/8"  | 8.75" OAL  | 6FJX - 6FJX    | 2   |
| 18 | 1/4"  | 20" OAL    | 6FJX - 6FJX90L | 1   |
| 19 | 1/4"  | 22" OAL    | 6FJX - 6FJX90L | 1   |
| 20 | 1/4"  | 18" OAL    | 6FJX - 6FJX90  |     |
| 21 | 1/4"  | 14" OAL    | 6FJX - 6FJX45  |     |

**NOTE:** Hoses are not available for sale. Use the information above to have replacement hoses made up locally. All hoses should be double braid, with crimps rated for at least 3500 psi.

**FRONT PANEL – ROLLERS**

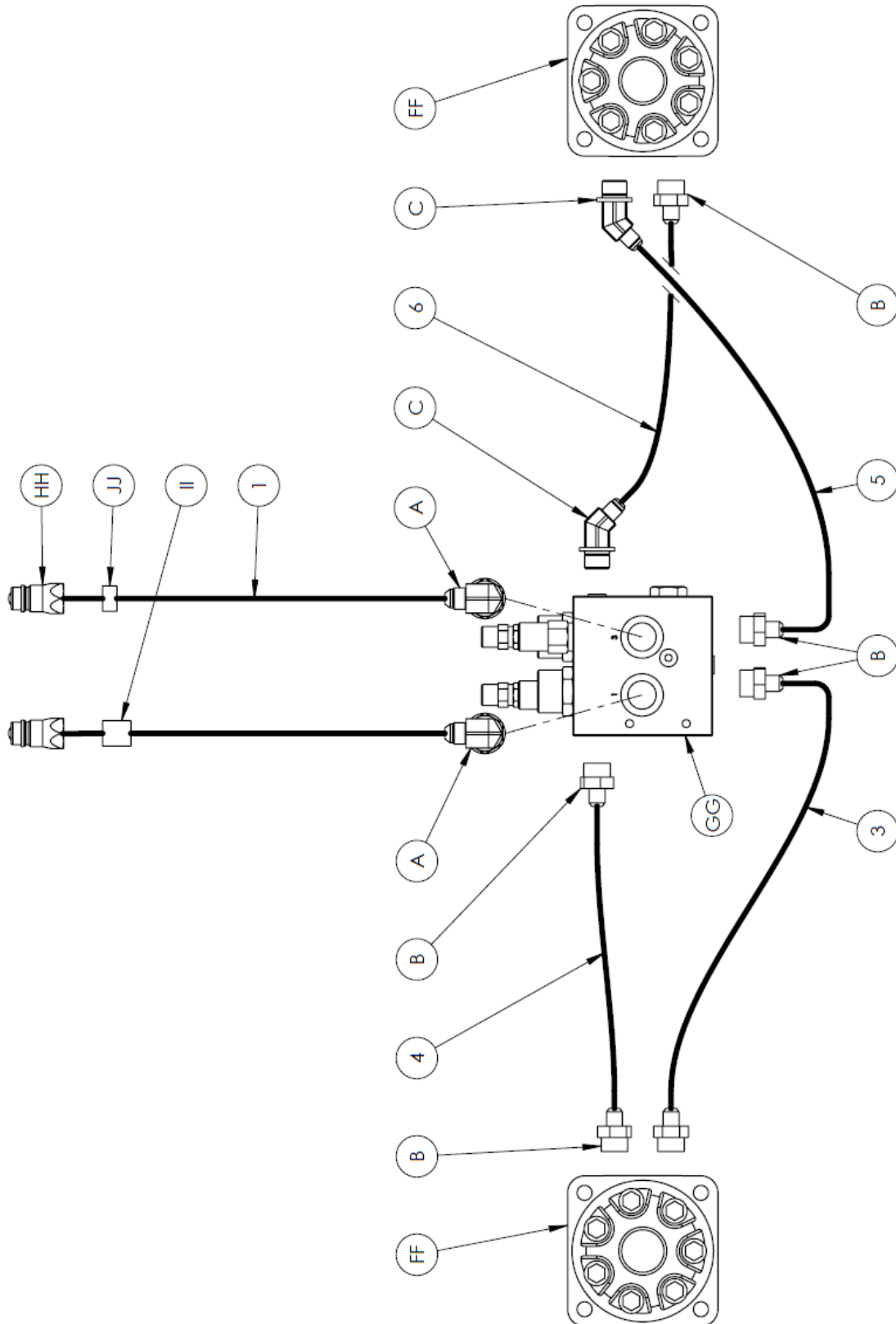

**FRONT PANEL – DEFLECTOR & WING**

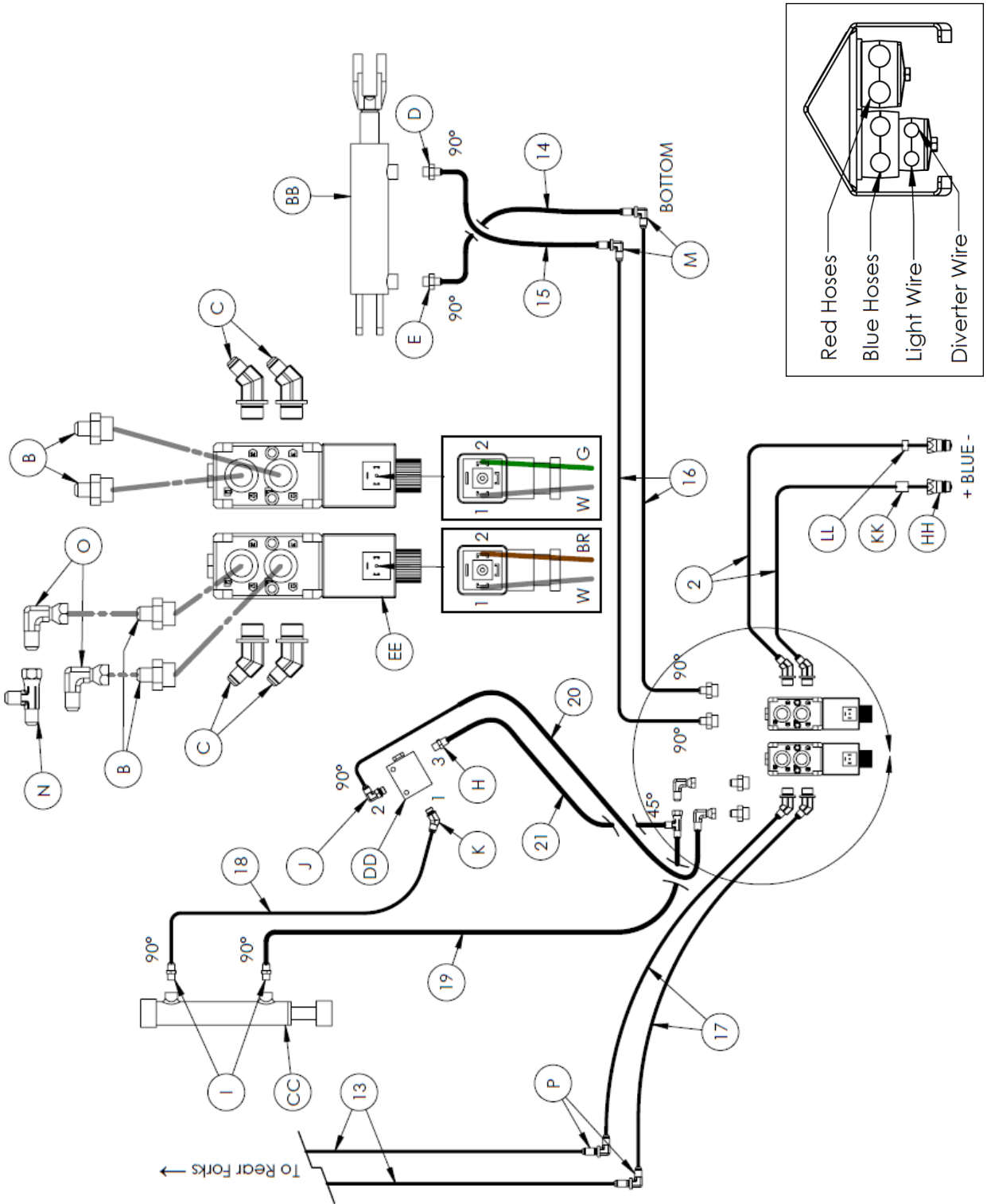

**REAR PANEL – FORKS**

