

## PULLDOZER

**1810    1810XL    2410    2410XL**

### **Operator, Assembly & Parts Manual**

Last Updated: December 15, 2025

**Bridgeview Manufacturing Inc.**  
P.O. Box 4  
Gerald, Saskatchewan, Canada  
S0A 1B0  
Phone: 1-306-745-2711  
Fax: 1-306-745-3364  
Email: [bridgeview@bridgeviewmfg.ca](mailto:bridgeview@bridgeviewmfg.ca)  
[www.bridgeviewmanufacturing.com](http://www.bridgeviewmanufacturing.com)

<b>Your Authorized Dealer</b>
<b>Your Serial Number</b>

The serial number is located on the back of the blade on the left side of the machine.



# TABLE OF CONTENTS

<b>1</b>	<b>INTRODUCTION</b> .....	4
1.1	Safety Precautions .....	4
1.2	Transportation .....	7
<b>2</b>	<b>OPERATION</b> .....	9
2.1	Hitch Options.....	10
2.2	Tires.....	11
2.3	Lubrication .....	11
2.4	Blade Options.....	12
2.5	Trencher Option.....	13
2.6	GPS Option.....	15
<b>3</b>	<b>ASSEMBLY &amp; PARTS MANUAL</b> .....	16
3.1	Component Information (1810/2410) .....	16
3.2.	Body Assembly .....	21
3.2	Hydraulics Assembly.....	30
3.4.	Electrical Assembly .....	43
3.5.	Miscellaneous .....	51
3.6.	Trencher Option.....	61
3.7.	Decals.....	65
	<b>NOTES</b> .....	75



## 1. INTRODUCTION

Thank you for purchasing a Pulldozer from Bridgeview Manufacturing. With the proper operation and service as outlined in this manual, the Pulldozer will provide you with years of trouble free operation.

This is a complete safety, operation and parts manual for the Pulldozer. The manual covers in detail how to safely and effectively use your new machine. The procedures outlined in this manual should be followed to ensure safe operation and longevity of your machine. The parts and assembly manual covers all parts you may need to order in case of accident or breakdown and how to install them. Please read completely through this manual before beginning operation of your new machine.



### 1.1 Safety Precautions

#### Power Requirements:

The Pulldozer is designed to utilize the pulling power of a large four-wheel-drive tractor. The following table shows the recommended drawbar horsepower required to use each size Pulldozer. Pulling with too large a tractor risks damaging the machine, while too small a tractor risks overloading and damaging the tractor.

	Horsepower	Maximum Tractor Weight
<b>18 Foot</b>	250 - 400 HP	60,000lbs
<b>24 Foot</b>	400 - 600 HP	67,000 lbs.



**Call Before You Dig:**

Every time you dig in the ground, wherever it may be, **THERE IS DANGER BELOW!** You run the risk of loss of life or damage to property if you hit any of the many buried cables, conduits, gas or oil pipelines and/or other underground facilities that serve our cities, towns, and rural areas.

Contact the nearest **ONECALL (Call Before You Dig)** services for optimal diligence towards preventing damage to underground infrastructure.



Canada		
Province	Number	Website
British Columbia	1.800.474.6886	<a href="http://www.bconecall.bc.ca/">http://www.bconecall.bc.ca/</a>
Alberta	1.800.242.3447	<a href="http://www.alberta1call.com/">http://www.alberta1call.com/</a>
Saskatchewan	1.866.828.4888	<a href="http://www.sask1stcall.com/">http://www.sask1stcall.com/</a>
Manitoba	1.800.827.5094	<a href="http://www.callb4udig.mb.ca/">www.callb4udig.mb.ca/</a>
Ontario	1.800.400.2255	<a href="http://www.on1call.com/">http://www.on1call.com/</a>
Quebec	1.800.663.9228	<a href="http://www.info-ex.com/">http://www.info-ex.com/</a>
United States		
All states	811	<a href="http://www.call811.com/">http://www.call811.com/</a>
TransCanada Pipelines		
Canada	1.888.982.7222	
United States	1.800.447.8066	



**Hydraulic Systems:**

Hydraulic systems store considerable energy. They are used to:

- lift and change the position of attachments
- operate hydraulic motors
- assist in steering and braking

Leaks from hydraulic systems are a serious hazard because of the high pressure and temperature of the fluid contained in the system. Even fine jets of hydraulic fluid can burn or pierce skin and tissue. Workers should:

- Never inspect hydraulic hoses with bare hands;
- Wear long sleeves, heavy gloves and safety glasses when checking for leaks;
- Follow the instructions (blade to be on the ground and no pressure in hydraulic lines during maintenance) because the specific procedures for servicing these systems are very important for one's safety.

Where appropriate, a properly qualified and certified mechanic should perform repairs and maintenance.

Work should not be performed under raised hydraulic equipment.



## 1.2 Transportation

Check with local authorities regarding transport on public roads. Follow all applicable laws and regulations.

Note the transportation dimensions shown below:

	<b>1810</b>	<b>1810XL</b>	<b>2410</b>	<b>2410XL</b>
<b>Total Weight</b>	18000 lbs	22000 lbs	24000 lbs	28000 lbs
<b>Hitch Weight</b>	6000 lbs	7600 lbs	7500 lbs	9000 lbs
<b>Axle Weight</b>	12000 lbs	14400 lbs	16500 lbs	19000 lbs
<b>Transport Height</b>	9'-5"		10'-5"	
<b>Flat Height Blade to Top</b>	8'-1"		8'-11"	
<b>Transport Blade Clearance</b>	2'-0"		2'-0"	
<b>Transport Width (Blade)</b>	18'-5"		24'-5"	
<b>Transport Width (Tires)</b>	14'-2"		22'-0"	
<b>Transport Length</b>	26'-7"		26'-2"	

When transporting the Pulldozer on public roads, the following precautions should be taken:

- Avoid transporting at night whenever possible
- Always ensure that the flashers and tail lights are clean and operational
- Always ensure that the Slow Moving Vehicle (SMV) sign is visible
- NEVER exceed speeds of 25 mph (40 km/h)
- DO NOT tow with a vehicle that cannot handle the massive weight of the Pulldozer
- Check for the oversize or overload permit with the authorities for transportation on public highways.
- Ensure that blade is fully lifted, level, and not in contact with the road (maintain a safe level from the ground).
- Ensure that the trencher attachment (if installed) is fully retracted.
- Ensure that all safety locks are in place
- Ensure that the hydraulic hoses are properly secured (not dragging on the ground)



**Transportation Locks:**

Ensure that all the safety locks and pins are ON in the right position while transporting. This will prevent the blade from accidentally falling during transport.

1. Blade lift lock (both sides) - swing over cylinder shaft
2. Tilt lock (both sides) - swing over cylinder shaft
3. Trencher lock - insert pin through hole

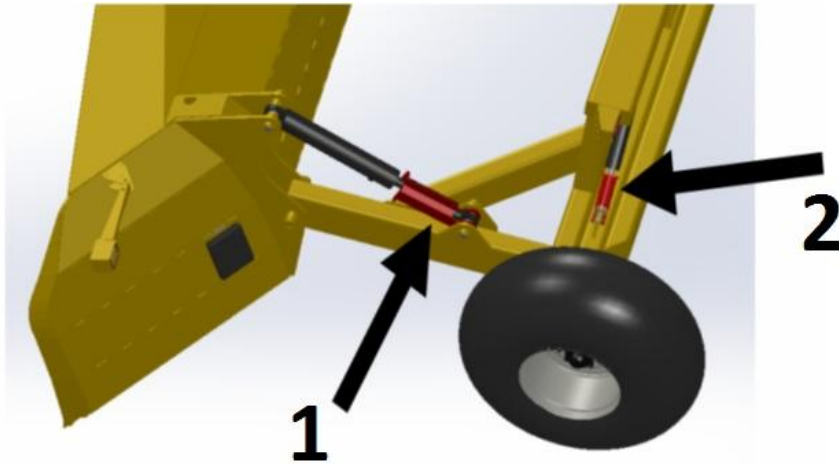

*Figure 1.2.1: Shows the safety locks marked by arrows*



## 2 OPERATION

The Pulldozer land shaper operates as a dozer, scraper, grader, and V-ditcher (XL series) all in one complete, efficient, and virtually indestructible package.

The Pulldozer is capable of reclaiming unproductive land to allow for more seeded acreage. It can also drag dirt to elevate sloughs and potholes, level land, back-slope, clean and contour existing ditches and drains to improve draining, and allow for sooner access by seeding equipment.

When mated with a GPS leveling system, the Pulldozer is excellent at making perfectly contoured fields for maximum drainage, or water retention.

Operators have reported 1 acre per hour of land reclamation, leaving it seed bed ready.

The Pulldozer allows for up to 25 cubic yards of dirt movement over short distances for the 24 foot unit, and up to 18 cubic yards for the 18 foot unit.

The retractable trencher allows for trenches up to 36" wide by 24" deep, while leaving no windrow ridges to interfere with draining. This allows most farm equipment to easily drive right over the trench on an angle.

Enjoy operating your new Pulldozer.



### 2.1 Hitch Options

Your Pulldozer comes with a choice of two different articulating implement hitches. Category 4 has draw pin sizes of 1-1/2 and 2" (interchangeable) and Category 5 has a standard draw pin size of 2-3/4".

Draw Pin Size (inches)	Hitch Required	Part NO
1.50	Flanged Bushing	27373
2.00	Category 4 * with 2" bushing installed, 2 Hole Pattern	27371
2.00	Category 4 * with 2" bushing installed, 3 Hole Pattern	27372
2.75	Category 5, 2 Hole Pattern	30128

The articulating joint reduces drawbar and draw pin wear thereby increasing the life of drawbar. This hitch allows more control, especially with GPS navigation.

Also important is the hitch height. For maximum articulation, the hitch must be set to the correct height based on your tractor's drawbar height as follows.

Holes Used	Drawbar Height (inches)
1,2	20.50
2,3	18.25
3,4*	16.00
4,5	13.75
5,6	11.50

*\* Factory setting*

For maximum articulation, a 3-5/8" clearance between the drawbar and hammer strap is also recommended. This will allow for 35 degrees front to back and 40 degrees side to side. This translates into a 10% grade (or 17 degree slope).

**- NOTE: Exceeding this articulation range may damage or break the hitch – Breakage due to exceeding articulation range will no be covered by warranty!**

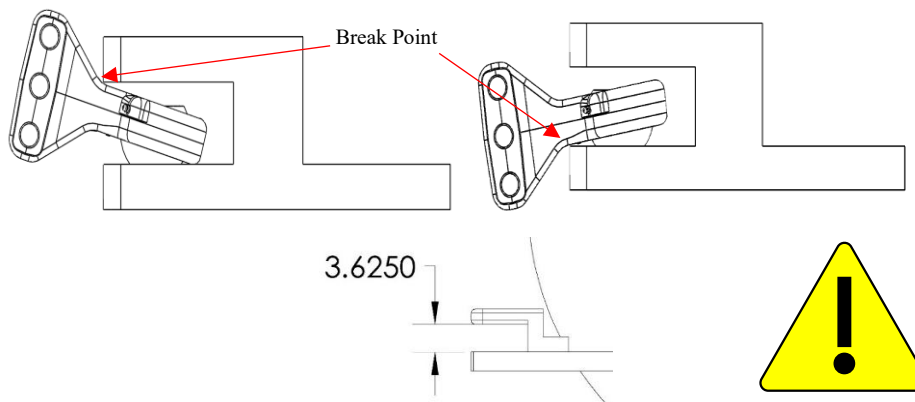

Figure 2.1 – Articulation clearance



### 2.2 Tires

Diamond tread tires provide excellent flotation characteristics and minimal soil disturbance on packing and hauling applications. The speed and pressure on these tires should not exceed 25 mph (40 km/h)) and 36 psi (250 kPa).

Check tire pressure and wheel torque on a regular basis.

Specifications	1810	2410
Tire Size	23.1-26, 12 ply	28L-26, 16 ply
Tire Type	R3 Diamond Tread	R3 Diamond Tread
Rim Size	DW20A-26	DW25B-26
Tire Pressure	<b>16 psi</b>	<b>24 psi</b>
Wheel Nut Torque	<b>280 ft-lb</b>	<b>280 ft-lb</b>

### 2.3 Lubrication

There are several pivot points on your Pulldozer that require lubrication for continuing performance. They are located in the following areas:

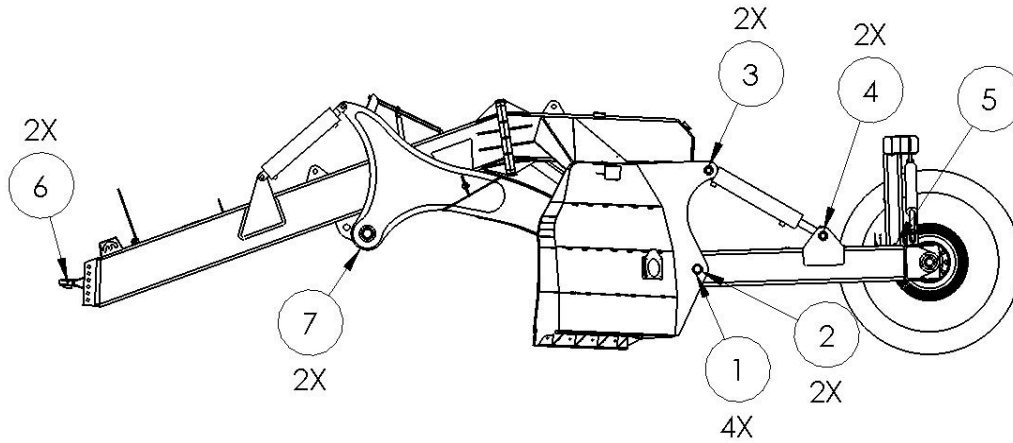

		Location	Interval
1	Blade Pivot	Outside bushings	10 hours
2	Blade Pivot	Center	10 hours
3	Lift Cylinder	Facing towards top	20 hours
4	Lift Cylinder	Facing towards top	20 hours
5	Axle Pivot	Behind SMV Sign	10 hours
6	Hitch	Each side of casting	20 hours
7	Trencher Pivot	Bottom	10 hours
9	Wheel Hub	Remove dust cap and pack with grease	100 hours or seasonally

*Grease using Mobil UNIREX EP2 GC-LB or equivalent.*



## 2.4 Blade Options

Efficient machine applications require the proper dozer attachments for the job at hand. Dozers are used in a wide variety of construction and maintenance applications for which a number of blade types have been developed. Soil characteristics, moisture content, compaction, ambient temperatures and terrain are just some of the variables that will influence proper blade selection for optimal dozing productivity.

Using the right blade for the job will result in fuel savings, higher productivity, less wear tear on the tractor and a better finished product. Some dozer blades are designed for a specific application, while others have a broader range of uses and are more often employed. The Pulldozer comes with a choice of two blades.

**1. Regular Blade:** General purpose operation. It has a penetration force of 1000 lb/ft. This is the factory standard.

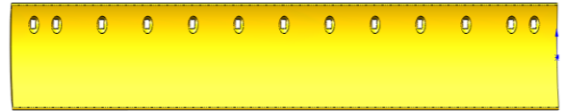

**2. Notched Blade:** More suitable for higher penetration requirements. It can withstand penetration force up to 2000 lb/ft. Operators have noted that this blade leaves the field in better condition for immediate seeding.

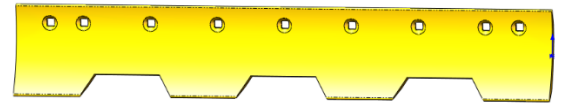

**NOTE:** These blades wear over time. Contact your nearest Pulldozer representative to order any additional blades.



## 2.5 Trencher Option

Trenching will drain your land fast; simply set the Pulldozer at ground level, and lower the trencher unit to the required depth and go.

As the trench is cut the dirt flows to the sides and is drawn outward by the Pulldozer. There is no windrow ridges of dirt left on the sides of the trench. As a result, your land will drain faster and with no side ridges you'll be able to work through the trench with most farm equipment. Operators report "smooth going" when crossing the trench at an angle.



*Figure: Trencher in retracted position*

Use the dirt from the trench to elevate low areas. When the Pulldozer is full simply raise the blade to dump and level the dirt. The Trencher can keep cutting while the Pulldozer is dumping and leveling.

The Trencher uses the full weight of the Pulldozer to keep it in the ground and works when the ground is wet or dry. Hardened cutting edges ensure long life.

In retracted position the Trencher does not interfere with normal operation. The trencher adds approximately 4,000 lbs. of weight to the Pulldozer.

NOTE: On standard machines, regular trenching can be done by tilting the blade to one side, and lowering the tip into the ground.





*Figure: Trench after the operation with no wind row ridges of dirt left*

**Depth Penetration:**

The trencher comes with a depth indicator showing the position of the trencher tip relative to the blade tip. This allows the operator to set the required trenching depth.

	Clean Depth	Max Depth	Width
18 Foot	Up to 22"	Up to 35"	36" wide
24 Foot	Up to 28"	Up to 42"	36" wide

*Table: Depth Penetration for 2410 and 1810 Pulldozer*

The maximum penetration of the trencher causes back filling of the trench if the blade is in contact with the ground. Lift the blade up for the regular trenching technique. For clean trenching, use in the "green" range of the depth indicator.



*Depth Indicator*



## 2.6 GPS Option

This GPS mounting tower kit (24763) is designed to be installed on any Pulldozer where GPS functionality is desired. On new machines one mounting location is provided: in the center of the blade behind the angle indicator.

Before starting, ensure that all required components are present:

ID#	Description	QTY
24761	GPS Mounting Tower	1
13806	3/8" x 1-1/4" Bolt	4
11667	3/8" Flat washer	4
10271	3/8" Serrated flange nut	4

The following tools are required to install this kit:

Lifting device Impact socket, 9/16" Hand wrench, 9/16"
--

Before installing the mounting bracket, install the GPS antenna to the top (hardware is not supplied). Use the nuts and bolts to hold the tower in place.

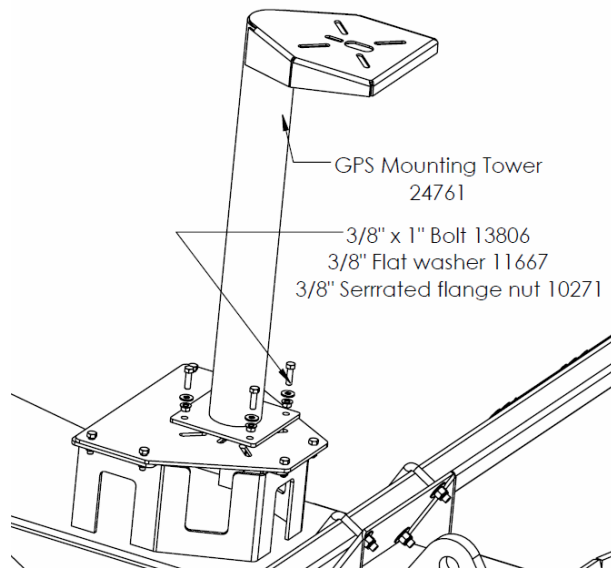

Figure 2.5 – Installing GPS tower



Route the electrical wires to the tractor cab through the grommets located on the rear and front bulkhead plates.



### 3 ASSEMBLY & PARTS MANUAL

#### 3.1 Component Information (1810/2410)

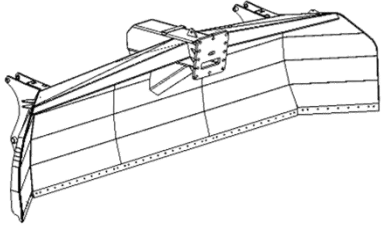
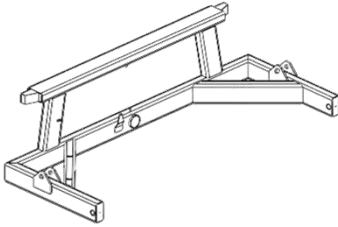
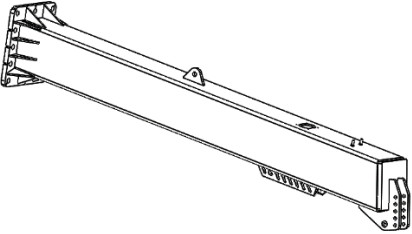
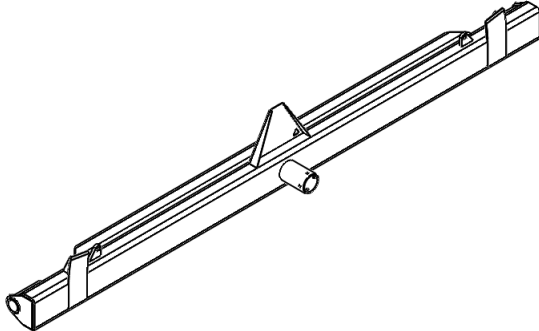
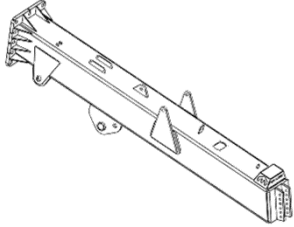
*NOTE: ID Numbers and weights showed as 1810/2410, where different.*

<p><b>Blade Weldment</b>  <b>30525/30530</b>                  Weight = 7200/11000 lbs.</p>	<p><b>Main Frame Weldment</b>  <b>30429/23331</b>                  Weight = 3150/3950 lbs.</p>
	
<p><b>Hitch Weldment</b>  <b>30420/31170</b>                  Weight = 1800/1700 lbs.</p>	<p><b>Axle Weldment</b>  <b>23334/23333</b>                  Weight = 2100/5400 lbs.</p>
	
<p><b>Trencher Hitch Weldment</b>                  ----/34508                  Weight = 2100/2000 lbs.</p>	<p><b>Trencher</b>  <b>23337/23336</b>                  Weight = 1100/1600 lbs.</p>
	



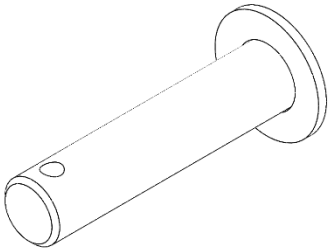
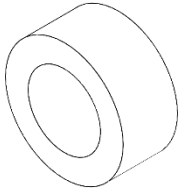
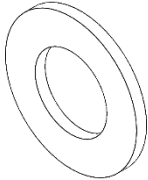
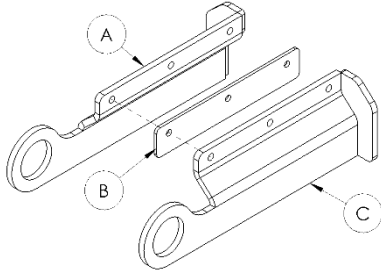
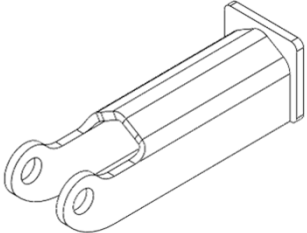
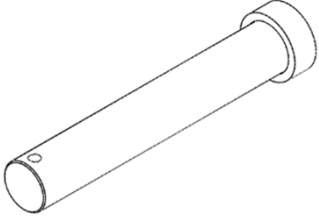
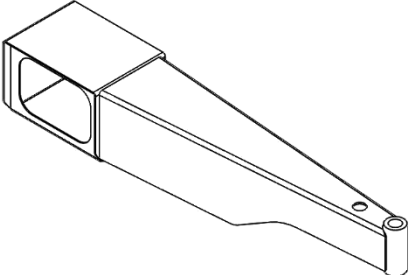
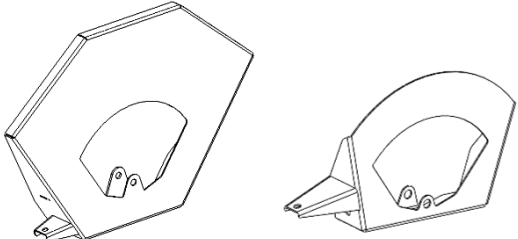

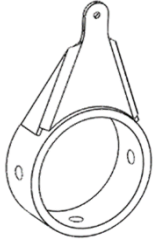
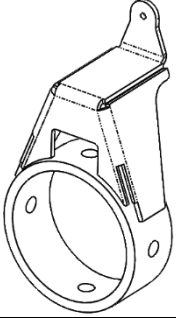
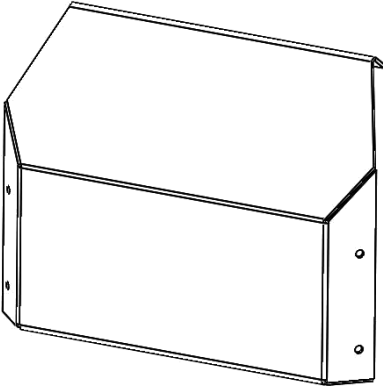
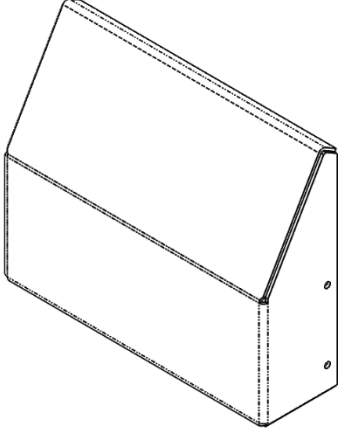
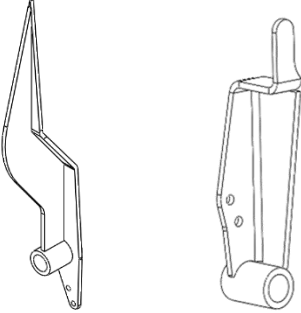
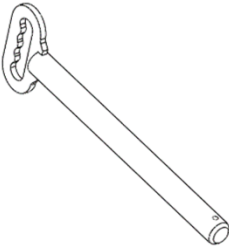

<p align="center"><b>Safety Chain Pin</b> 27224</p>	<p align="center"><b>Safety Chain Pin Bushing</b> 27245</p>
	
<p align="center"><b>Safety Chain Washer</b> 27244</p>	<p align="center"><b>Lift Cylinder Safety Lock</b> 22903 (A) / 23313 (B) / 23315 (C)</p>
	
<p align="center"><b>Tilt Cylinder Safety Lock Weldment</b> 21228</p>	<p align="center"><b>Blade Pin Weldment</b> 23338</p>
	
<p align="center"><b>Flasher Light Weldment</b> 23339</p>	<p align="center"><b>Angle Indicator Bracket</b> 31171                      22908</p>
	



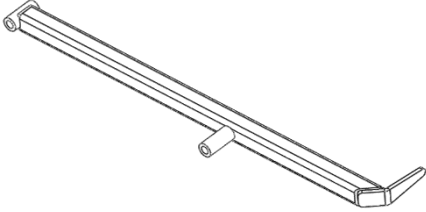
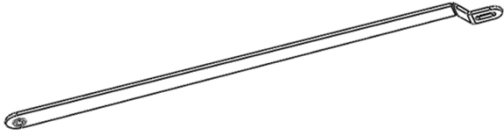

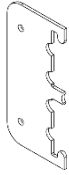

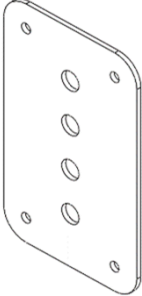
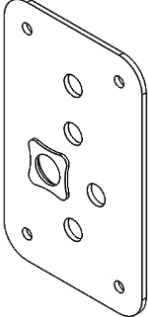
<p><b>Axle Collar Weldment</b> 27199</p>	<p><b>Angle Indicator Axle Pivot (2410 S/N PD1234 &amp; Up)</b> 30449</p>
	
<p><b>1810 Angle Indicator Cable Deflector</b> 30434</p>	<p><b>2410 Angle Indicator Cable Deflector</b> 30454</p>
	
<p><b>Angle Indicator Arm</b> 24060                      22911</p>	<p><b>Trencher Safety Pin</b> 22136</p>
	



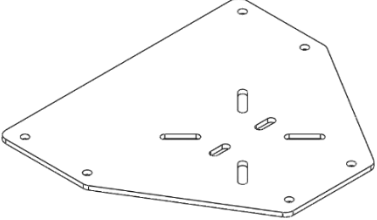
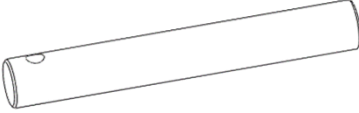
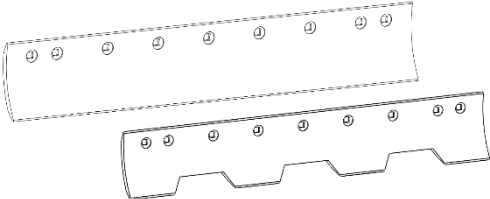

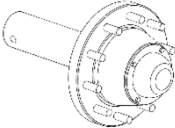
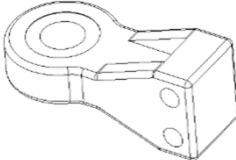
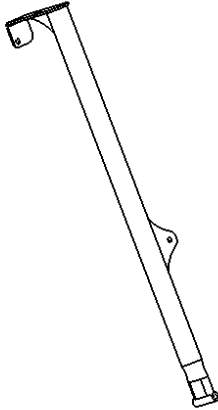
<p><b>Trench Depth Indicator Bracket</b> 27200</p>	<p><b>Trench Depth Indicator Arm</b> 22137</p>
	
<p><b>Trench Depth Indicator Linkage</b> 35509</p>	<p><b>Blade Pin Collar</b> 23342</p>
	
<p><b>Hitch Bulkhead Plate 1</b> 23343</p>	<p><b>Hitch Bulkhead Plate 2</b> 23344</p>
	
<p><b>Hitch Bulkhead Plate 3 (S/N PD1234 &amp; Up)</b> 30422</p>	<p><b>Hitch Bulkhead Plate 4 (S/N PD1234 &amp; Up)</b> 30424</p>
	
<p><b>Rear Bulkhead Plate</b> 23345</p>	<p><b>Rear Bulkhead Plate (S/N PD1234 &amp; Up)</b> 30427</p>
	



<p><b>Top Center Laser Mount Plate</b> 24010</p>	<p>Upper Lift Cylinder Pin (2" x 12-9/16"): 22912 Lower Lift Cylinder Pin (2" x 11-9/16"): 22913 Trencher Pivot Pin (2-15/16" x 26-13/16"): 22099</p>
	
<p><b>Blade Cutting Edge</b> Plain: 20428 x2 (4ft) / 20430 x3 (6ft) Serrated: 21426 x2 (4ft) / 21427 x3 (6ft)</p>	<p><b>Tires &amp; Rims</b> See Section 3.2 i</p>
	
<p><b>Hub &amp; Spindles</b> See Section 3.2 h</p>	<p><b>Articulating Hitch</b> See Section 3.2 k</p>
	
<p><b>Hydraulic Hose Hanger</b> 34493</p>	<p><b>Lights</b> 21419 (Red) / 21420 (Amber) 21421 (Grommet) / 21422 (Pigtail)</p>
	
<p><b>Chain Hose Holder</b></p>	<p><b>Hose Holder Top Clamp</b> 34507</p>

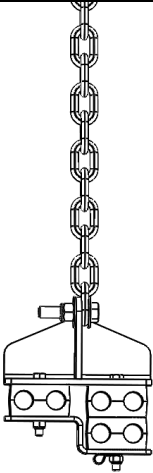
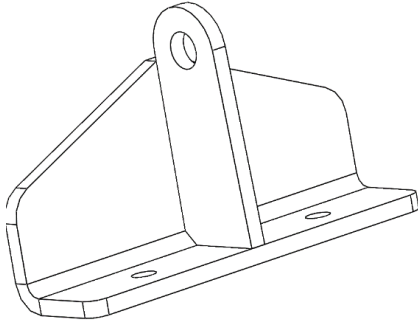
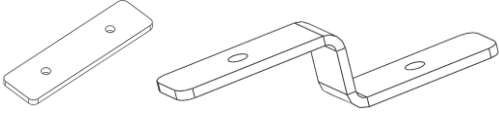

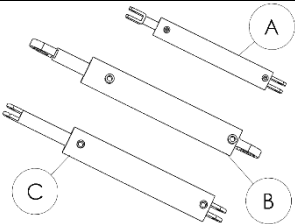
	
<p><b>Hose Holder Bottom Clamp (Straight/Bend)</b> <b>34506/34520</b></p>	<p><b><i>Hose Holder Chain (5/16")</i></b> <b>32168</b></p>
	
<p><b>Hydraulic Cylinder</b>  <b>A: 20488 (3x20" Tilt), 20807 (Seal Kit)</b>  <b>B: 23310 (5x24" Ball Style-Blade), 20808 (Seal Kit)</b>  <b>B: 20431 (5x24" Clevis Style-Blade), 20808 (Seal Kit)</b>  <b>B: 22729 (5x24" Tube Style-Blade), 20808 (Seal Kit)</b>  <b>C: 20431 (5x24" Trench), 20808 (Seal Kit)</b></p>	
	

### 3.2. Body Assembly

*NOTE: Parts may not be exactly as shown.*

*NOTE: Make sure you are aware of your serial number before ordering*

- a) Place the blade weldment upright on a stable level surface. Make sure the blade is blocked appropriately for stability.



- b) Using 1-1/2 x 5" bolts (20653), and hex nuts (20654) attach the hitch weldment (or trencher hitch weldment) to the neck of the blade subassembly. Washers (20434) must be placed on flange side without holders.

**Note: These bolts must be lubricated and torqued to 1800 ft-lb.**

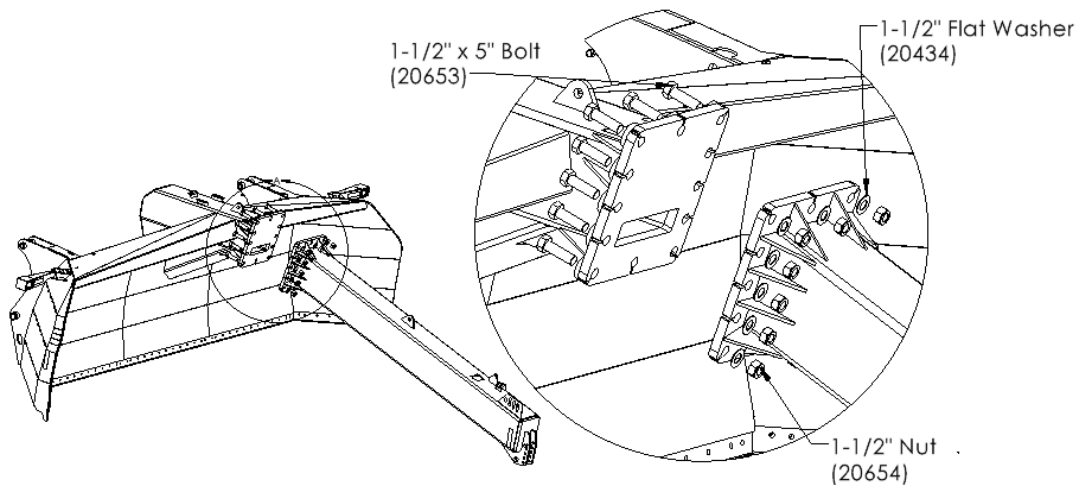

*Figure 1 - Blade to hitch Attachment*

- c) Lift the main frame weldment keeping it level and line it up with the mounting holes on the blade subassembly.

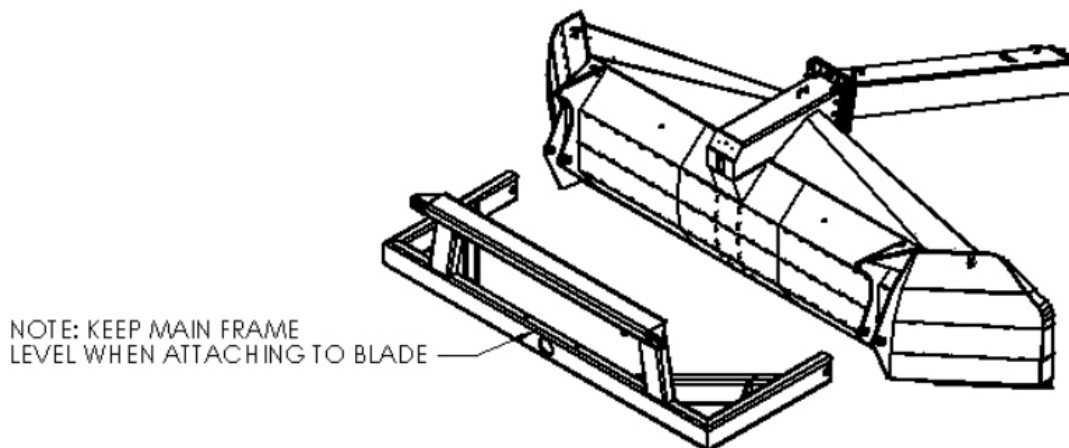

*Figure 2 - Main frame to blade alignment*



- d) Using the blade pins (23338), blade pin collars (23342), 1/2 x 4" bolts (15574), and 1/2" nylon lock nuts (10241), attach the main frame to the blade.

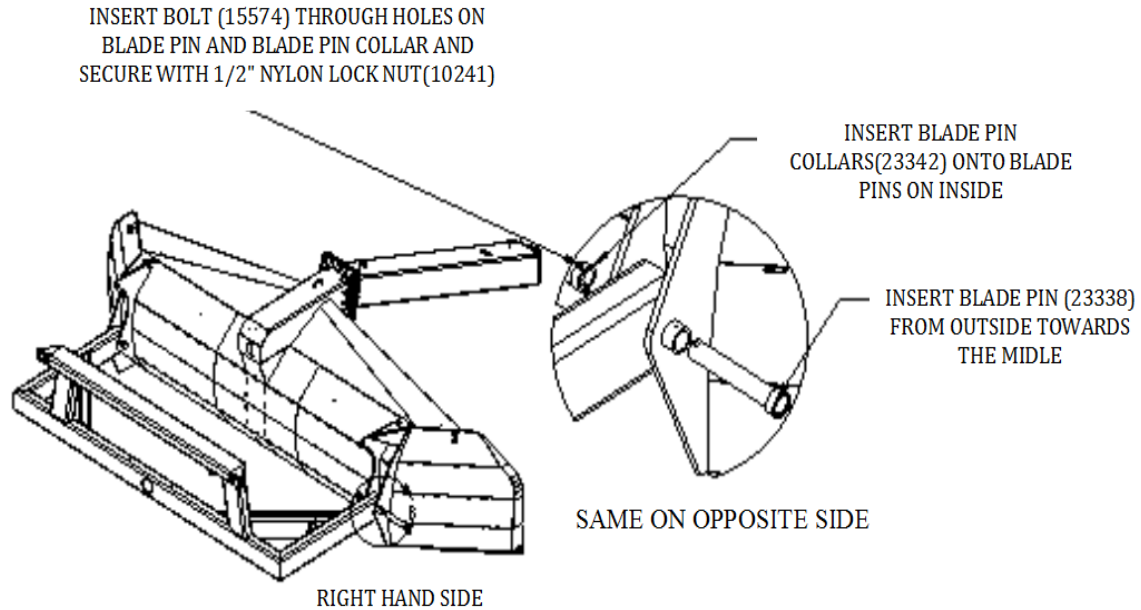

*Figure 3 - Main frame attachment*

- e) Place blocks under main frame in order to maintain its horizontal position.



- f) Attach the axle weldment to the main frame. Slide the axle into the main frame from the rear of the machine. Place the axle collar weldment onto the axle after sliding through the main frame. Then secure the axle in place with four 3/4" x 2" bolts (21243) and four 3/4" nylon lock nuts (10007).

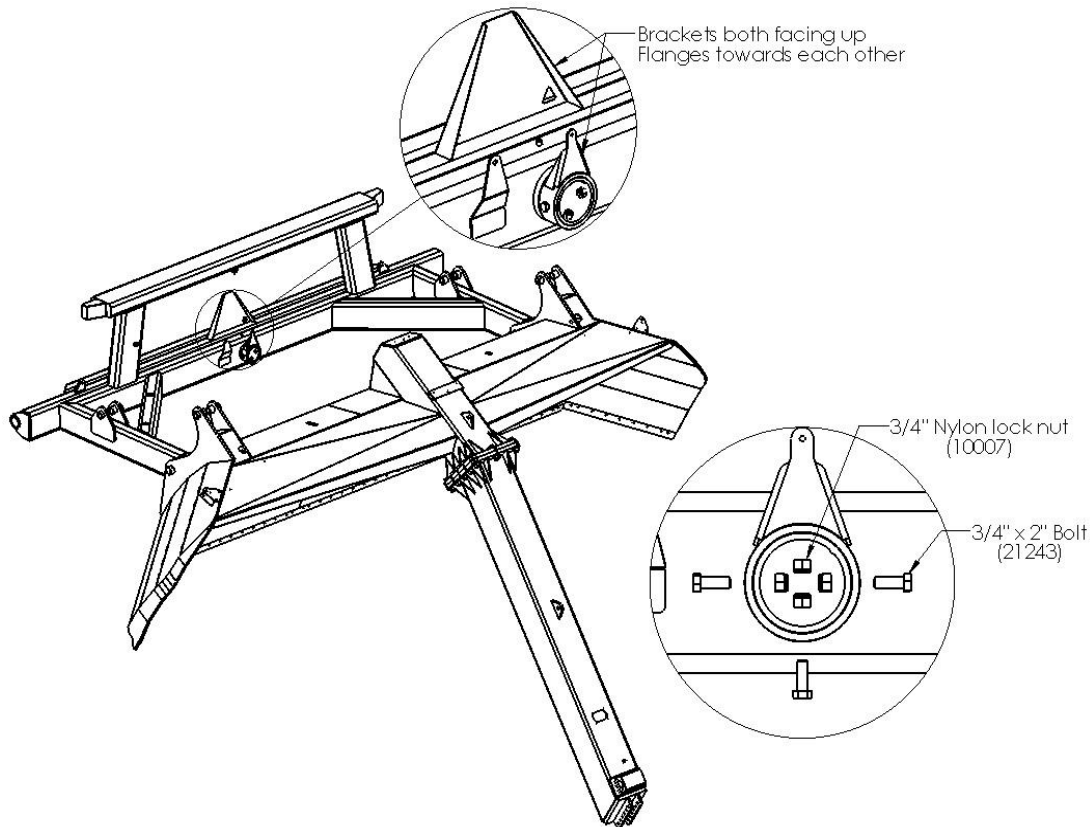

Figure 4 - Axle alignment



- g) Attach the axle weldment to the main frame. Slide the axle into the main frame from the rear of the machine. Place the Angle Indicator Axle Pivot onto the axle after sliding through the main frame. Then secure the axle in place with four 3/4" x 2" bolts (21423) and four 3/4" nylon lock nuts (10007). (2410 S/N PD1234 & Up)

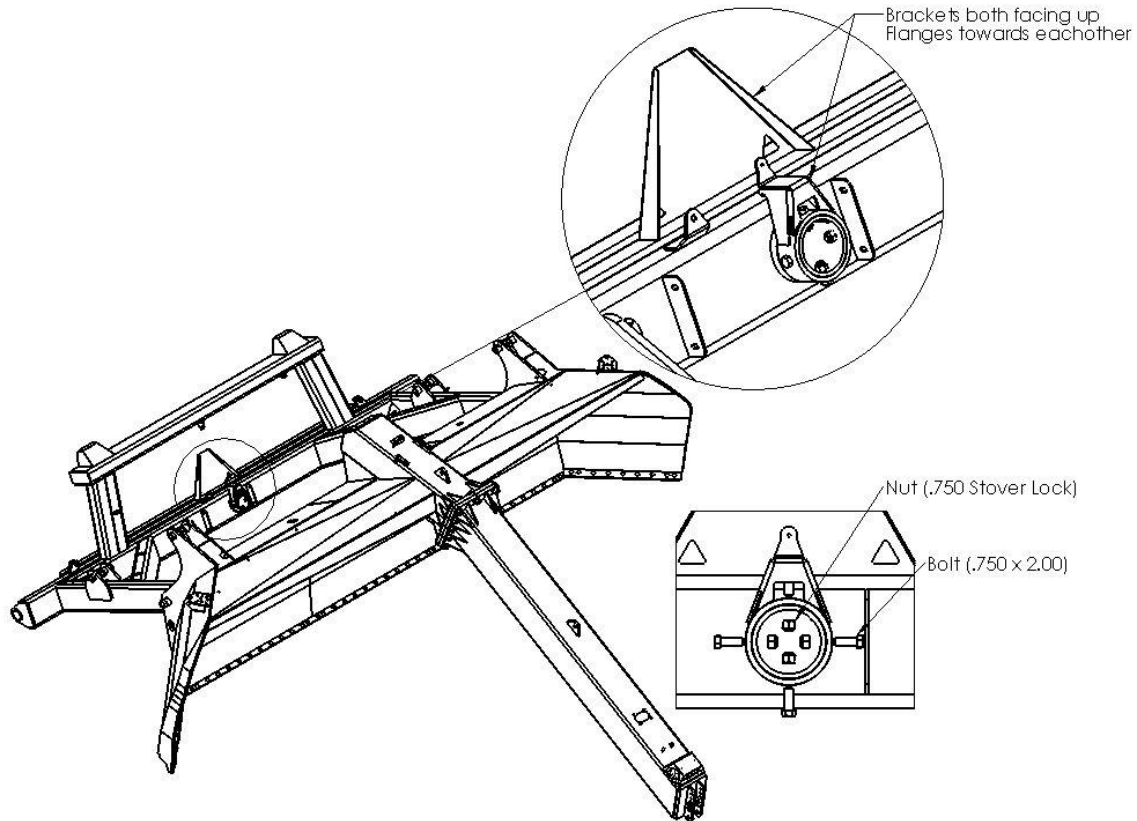

Figure 5 - Axle alignment

- h) Assemble the hub and spindle:
- Insert rear bearing (3) into the hub housing. Install the seal (6) (with rubber lip to the outside (as shown)). Lightly tap into place with a rubber mallet.
  - Pack bearings full of grease (Mobil UNIREX EP2 GC-LB). Run grease around the inside of the hub with a spatula to fill the opening.
  - Insert the spindle (2) as shown, with the shoulder up against the rear bearing.
  - Insert front bearing (4), washer (9), and castle nut (8).



- Rotate the spindle a few times and then repack with grease.

- REPEAT FOR SECOND HUB -

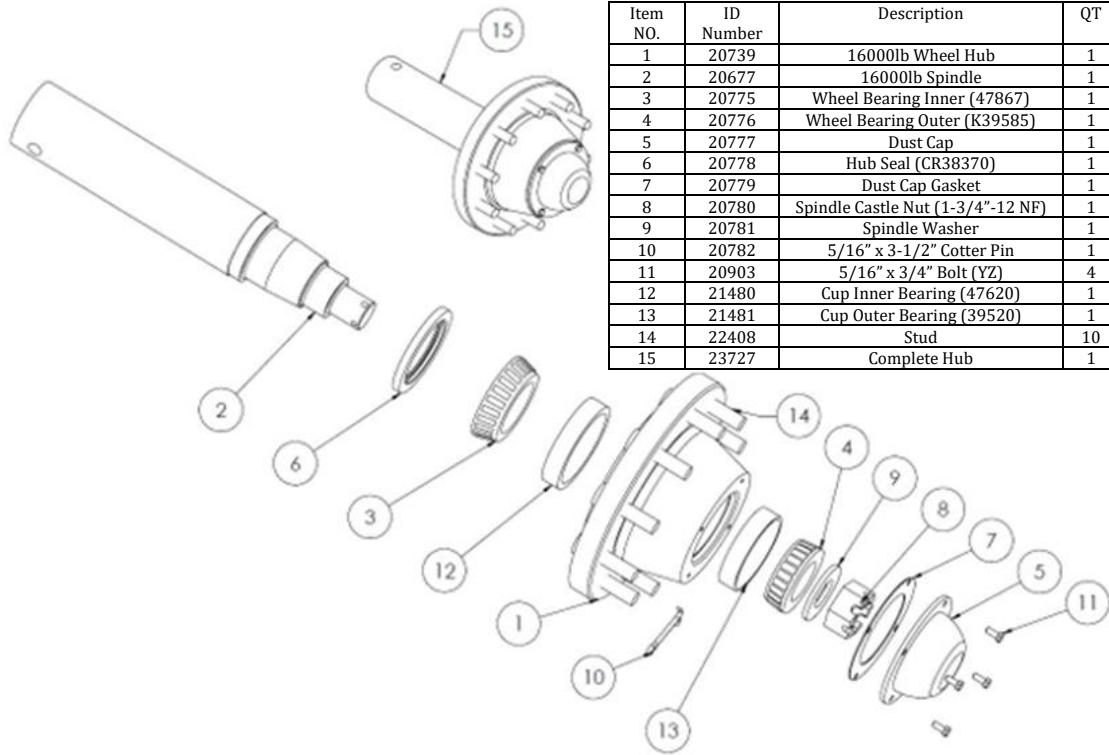

Item NO.	ID Number	Description	QT
1	20739	16000lb Wheel Hub	1
2	20677	16000lb Spindle	1
3	20775	Wheel Bearing Inner (47867)	1
4	20776	Wheel Bearing Outer (K39585)	1
5	20777	Dust Cap	1
6	20778	Hub Seal (CR38370)	1
7	20779	Dust Cap Gasket	1
8	20780	Spindle Castle Nut (1-3/4"-12 NF)	1
9	20781	Spindle Washer	1
10	20782	5/16" x 3-1/2" Cotter Pin	1
11	20903	5/16" x 3/4" Bolt (YZ)	4
12	21480	Cup Inner Bearing (47620)	1
13	21481	Cup Outer Bearing (39520)	1
14	22408	Stud	10
15	23727	Complete Hub	1

Figure 6 - Hub and spindle assembly

- Install both spindles to the axle using 3/4" x 6-1/2" (20787) bolts and nylon lock nuts (10007).
- Tighten the castle nut until the bearings are tight, and then back off one notch. Fix in place using the cotter pin (10).
- Install the dust cap (5), and gasket (7), using four 5/16" x 3/4" bolts (11).

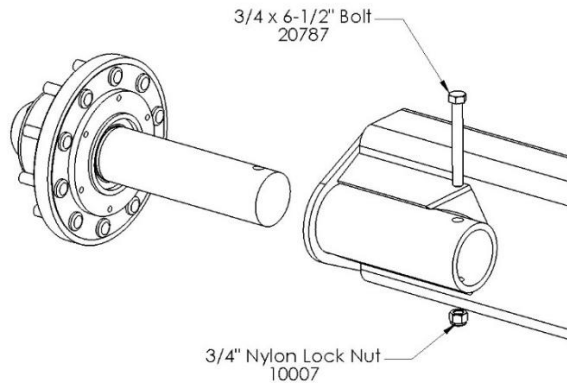
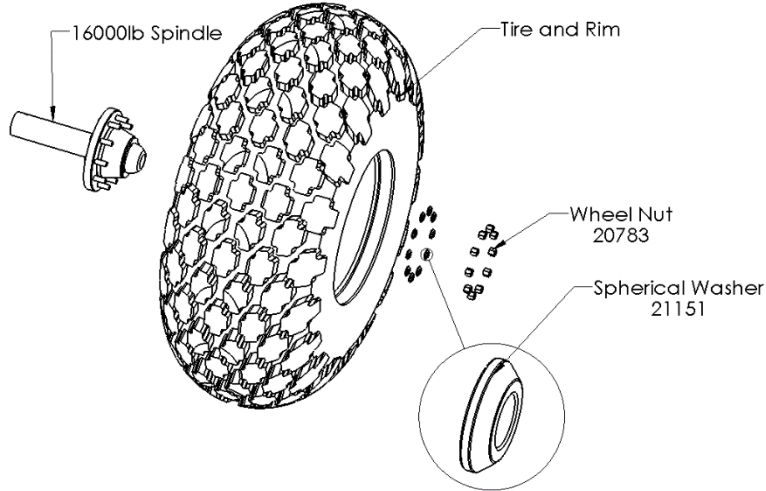

Figure 7 - Spindle to axle assembly



- i) Fasten the rim (21437 - 1810) - (21438 - 2410) to the hub using spherical washers (21151) and wheel nuts (20783). The flat side of the spherical washers should contact the surface of the rim with the spherical side against the wheel nuts.

**NOTE: Valve stem towards outside.**



*Figure 8 - Hub and wheel assembly*

Make sure that the tires are inflated to their correct pressure and the wheel nuts are torque properly (see chart below). Remove the blocks from the main frame and allow the frame to sit on the wheels.

Specifications	2410	1810
Tire Size	28L-26, 16 ply	23.1-26, 12 ply
Tire Type	R3 Diamond Tread	R3 Diamond Tread
Rim Size	DW25B-26	DW20A-26
Part# (Tire and Rim)	20675	20900
Tire Pressure	24psi	16psi
Wheel Nut Torque	280 ft-lb	280 ft-lb



- j) Bolt the angle indicator deflector 30434/30454 (1810/2410) onto the main frame with a 1/2" x 1-1/2" bolt, 1/2" flat washer on both sides of the deflector, and a 1/2" nylon lock nut.

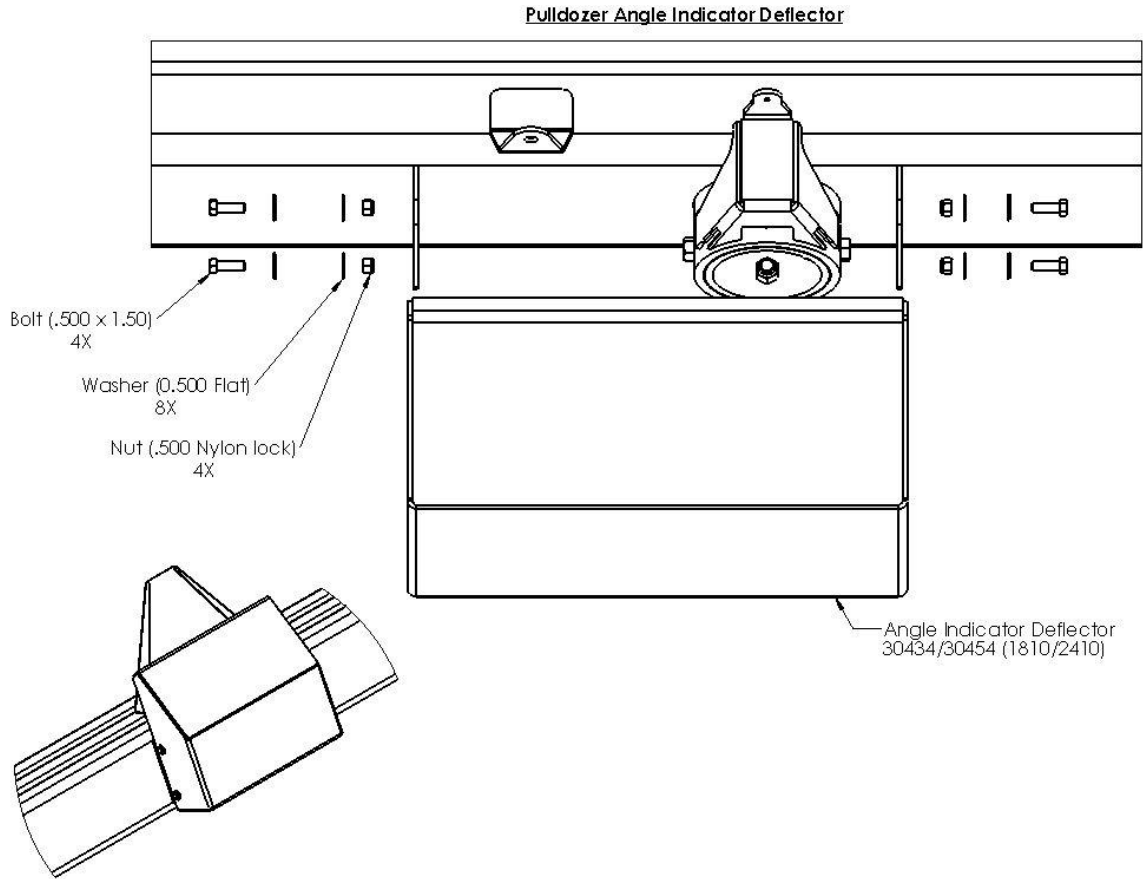

Figure 9 – Angle Indicator Deflector

Bolt the articulating hitch to the front of the hitch subassembly using two 1 x 7-1/2" NF Gr.8 bolts (21103), and Stover lock nuts (21104). In order to ensure a tight fit for the hitch, shims will need to be installed as needed (see chart).

Part Number	Description	Thickness
33891	Bullpull Hitch Shim A	10 gauge
33892	Bullpull Hitch Shim B	12 gauge
33893	Bullpull Hitch Shim C	14 gauge
33894	Bullpull Hitch Shim D	16 gauge



Set to the desired height (use closest setting):

Holes Used	Drawbar Height (inches)
1,2	20.50
2,3	18.25
3,4 *	16.00
4,5	13.75
5,6	11.50

\* *Factory setting*

Make sure that the *lettering is on the top side*. The Category 4 hitch has two available pin sizes, 1-1/2" and 2". Install the desired size by removing the snap ring from the bushing. Make sure that the bushing sticks out on the bottom.

Draw Pin Size (inches)	Hitch Required	Part NO
1.50	Flanged Bushing	27373
2.00	Category 4 * with 2" bushing installed, 2 Hole Pattern	27371
2.00	Category 4 * with 2" bushing installed, 3 Hole Pattern	27372
2.75	Category 5, 2 Hole Pattern	30128

\* *Comes supplied with both 1-1/2" and 2" bushings*

**Note: (21103) bolts must be torqued to 900 ft-lb.**

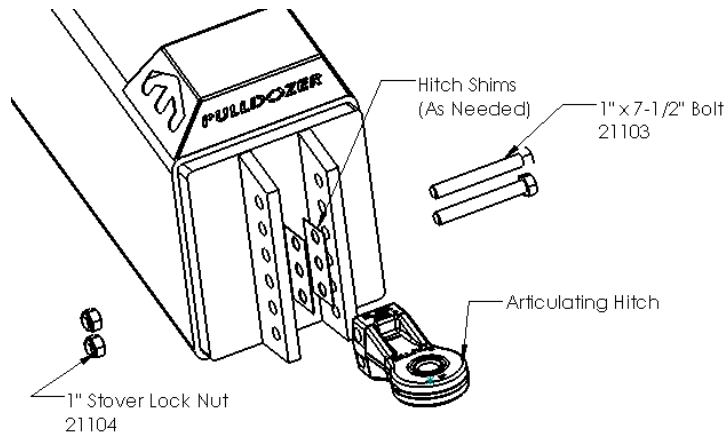

Figure 10 - Hitch installation (S/N PD1233 & Down)

**Note: (21103) bolts must be torqued to 900 ft-lb.**



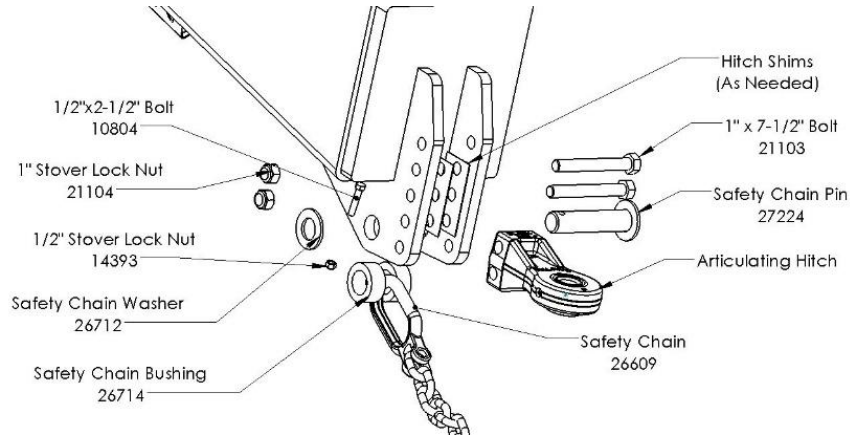

Figure 11 - Hitch installation (S/N PD1234 & Up)

### 3.2 Hydraulics Assembly

NOTE: Hydraulic cylinders must be attached at the top first then pulled down into position. A hydraulic schematic will be attached at the back of the Hydraulics Assembly Section.

- a) Align the 5 x 24" eyeball-end cylinders (23310) with the cylinder attachment holes on the blade subassembly (ports down, ram end to bottom). Insert upper cylinder pins (22912) into the blade holes with a 2" flat washer (23304) installed on each side of the eyeball and secure with 1/2" x 3-3/4" bolts (15397) and nylon lock nuts (10241).

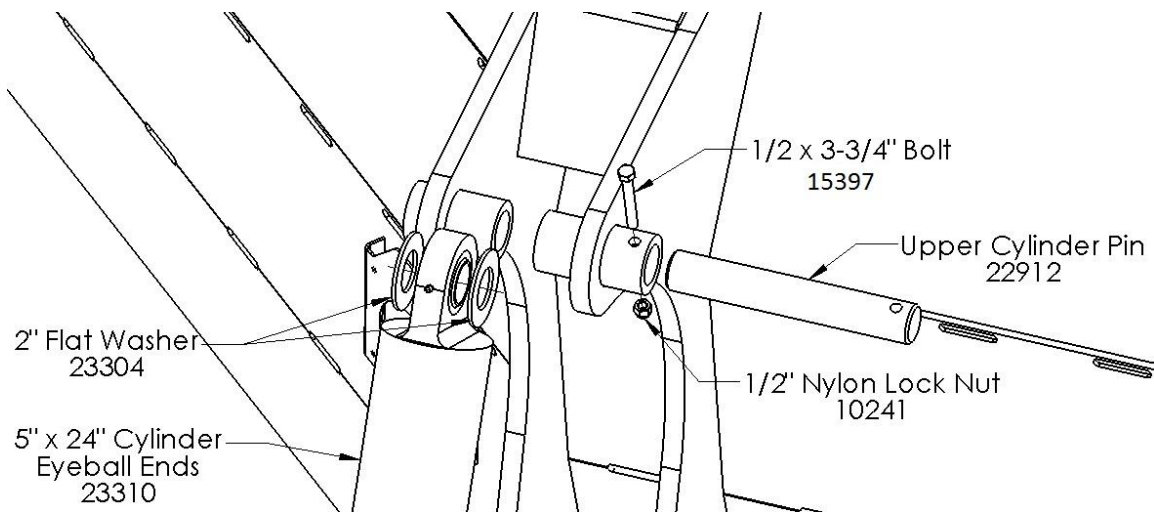

Figure 12 - 5 x 24" cylinder attachment (top)



- b) Install the lift cylinder safety locks to the main frame bushings. Slide the first half onto one side, then slide the second half onto the other side, then line them up with each other. Bolt the two halves together with the wear plate (23313) in between using three 1/2 x 2" bolts (10322) and nylon lock nuts (10241).
- c) Pull the ram ends of the cylinders down (grease zerk facing up) and align with the cylinder attachment bushings on the Pulldozer's main frame. Insert lower cylinder pins (22913) through the main frame holes and cylinder end with a 2" flat washer (23304) installed on each side of the eyeball. Secure with 1/2" x 3-3/4" bolts (15397) and nylon lock nuts (10241).

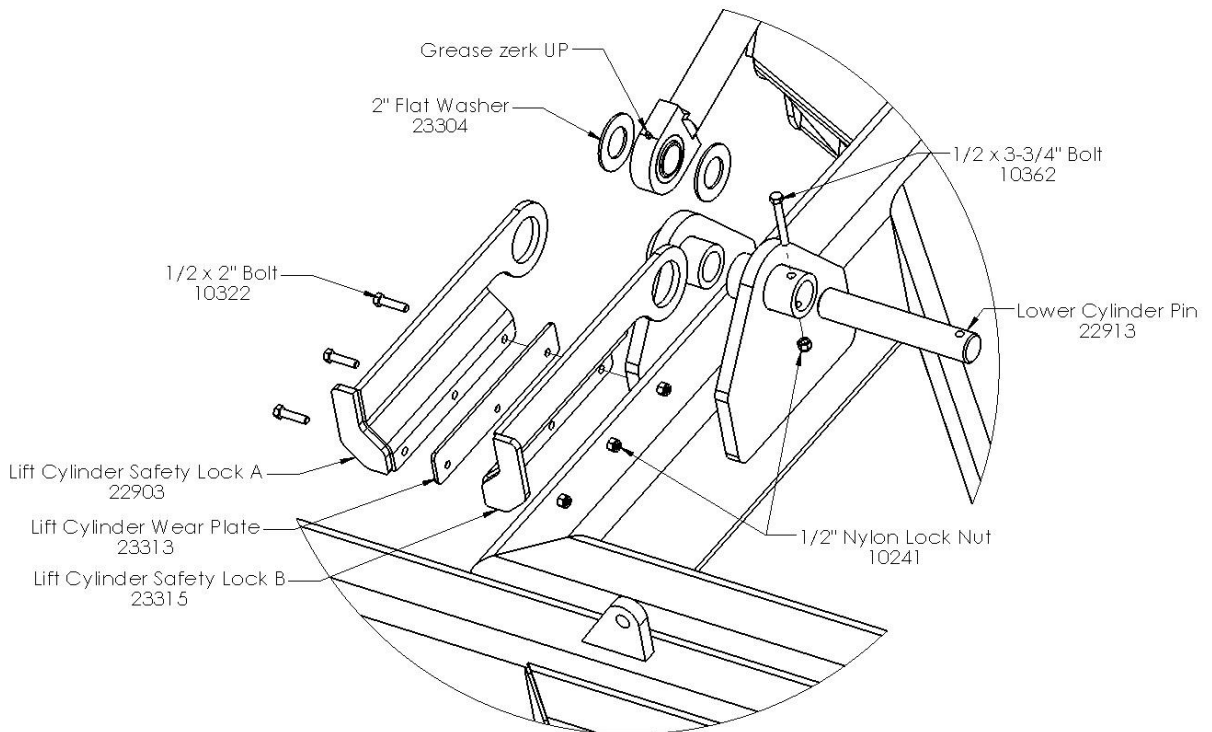

Figure 13 - 5 x 24" cylinder attachment (bottom)

- d) To install the two 3 x 20" hydraulic cylinders (20488), align the clevis on the barrel end of the cylinder with the cylinder attachment hole on the top bar of the main frame (ports down). Insert cylinder pin (10339) 1 x 2-7/8" through the clevis and cylinder attachment hole. Secure with 3/16" x 2" cotter pins (11670).



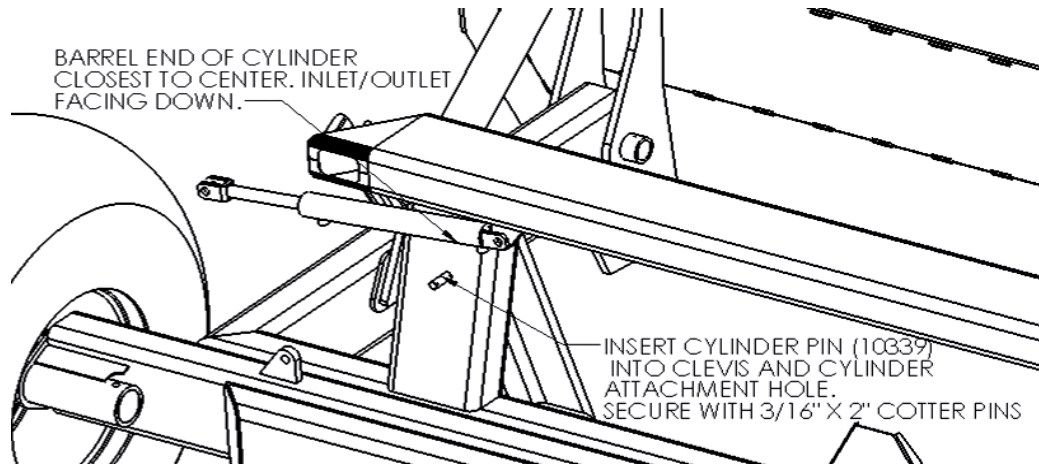

Figure 14 - 3 x 20" cylinder attachment (top)

- e) Pull the ram end of the cylinder down and align the clevis with the cylinder attachment hole on the Pulldozer's axle. Align the tilt cylinder lock (21228) with the clevis hole. Insert cylinder pin, 1" x 4-1/2" (20788), through the holes on the tilt cylinder lock, clevis, and axle. Secure with 1" flat washers (14472) on outside of cylinder locks and 3/16" x 2" cotter pins (11670).

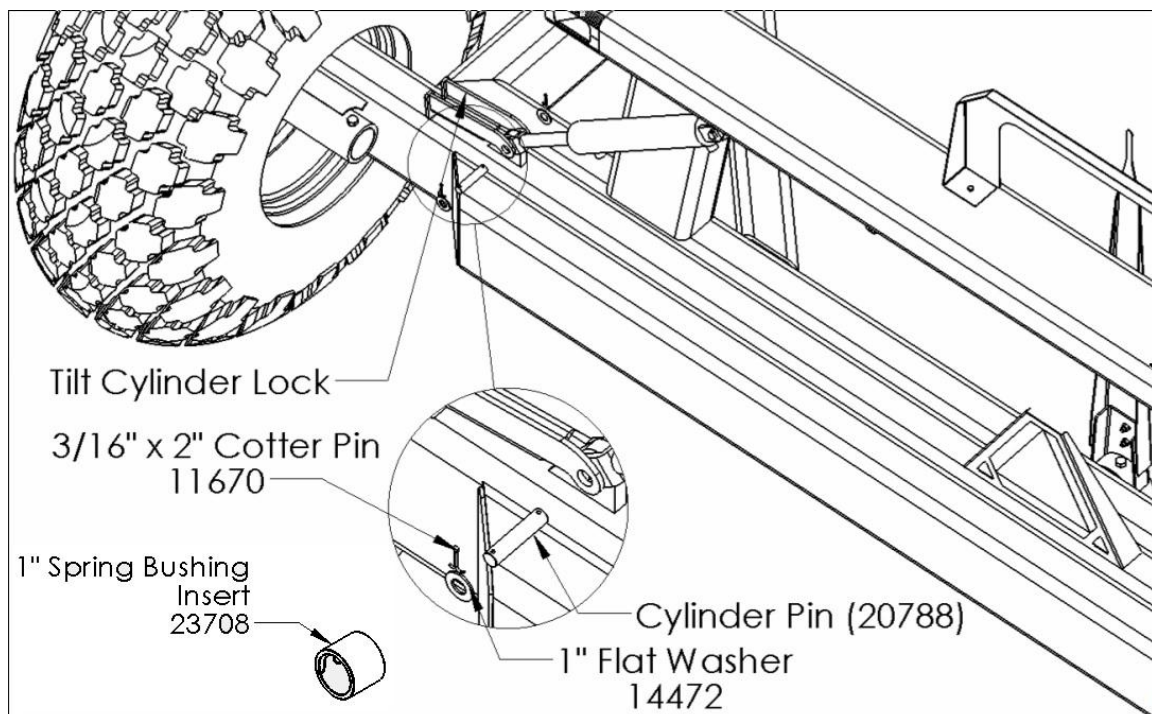

Figure 15 - 3x20" cylinder attachment (bottom)



f) Install cylinder port fittings:

- Install 12MB-8MJ90 fittings to each port of the 5" cylinders
- Install 6MB-6MJ90 fittings to each port of the 3" cylinders

Leave the fittings loose until the hoses are connected, then rotate to the position that works best for hose routing.

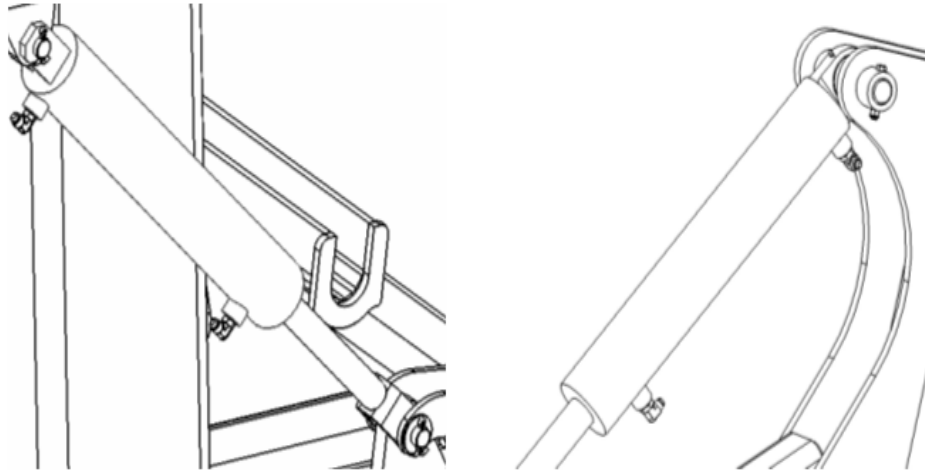

*Figure 16 - Cylinder port fittings*

g) Run hoses from cylinders to back of blade (see schematic at end of section). Install fittings on bulkheads as shown.

**NOTE: Do not install rear bulkhead plate until electrical wiring is complete.**

**Bulkhead is attached with 3/8 x 1-1/4" (10253) bolts.**



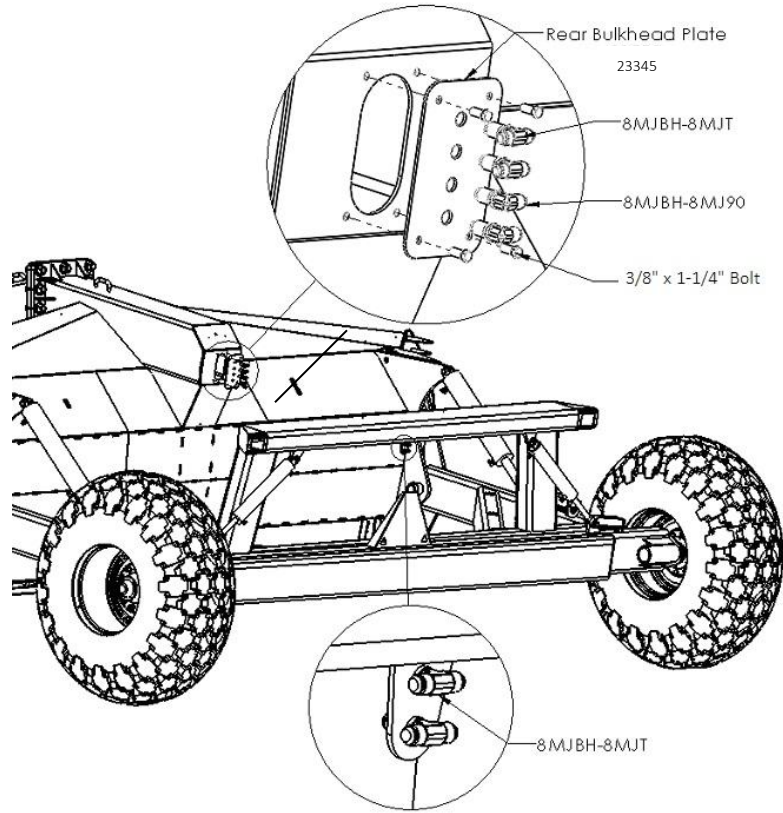

**Pulldozer S/N PD1234 & Up**

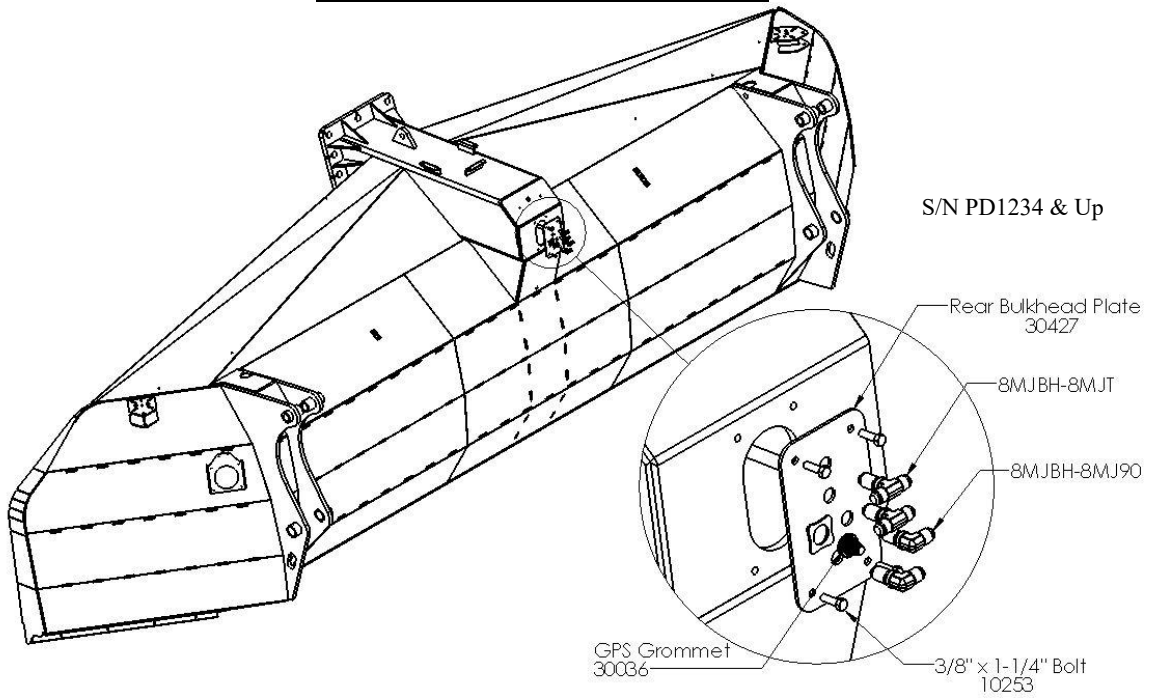

*Figure 17 - Rear bulkhead fittings*



h) Attach hoses to frame and blade using hose clamps.

**2410**

- 1/2" clamps on blade (x3), along bottom of main frame (x2), on the upright of the main frame (x1), and on the front of the main frame upper cross member (x1)
- 3/8" clamps on rear of main frame upper cross member (x2)

**1810**

- 1/2" clamps with cable clamps on blade (x3), along bottom of main frame (x2), and on the upright of the main frame (x1)

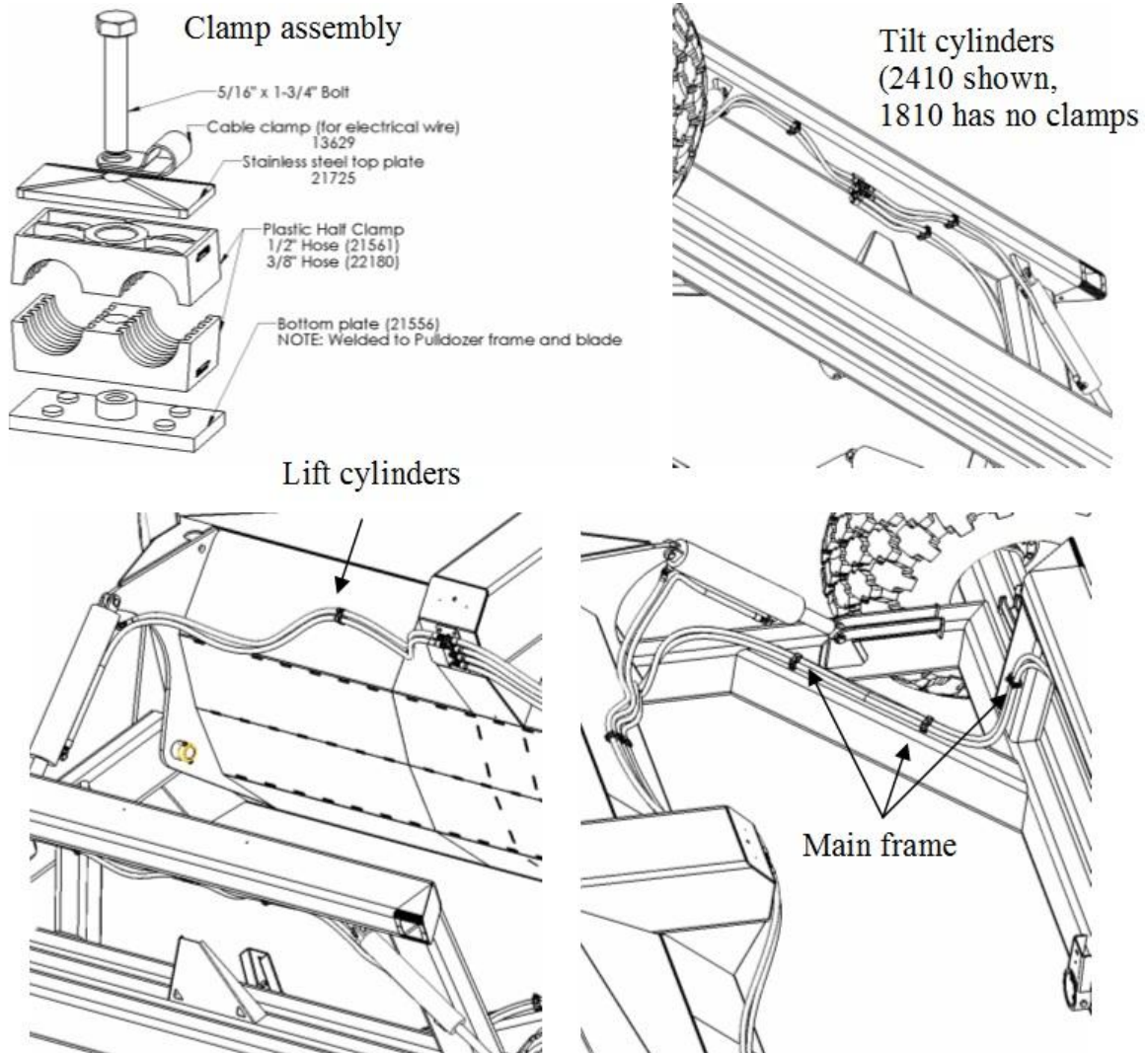

Figure 18 - Rear hose routing



- Tie any loose hoses together using zip ties or hose straps to complete the rear hose routing.
- Do not fully tighten the clamps yet as some of them will need cable clamps attached to the top.
- Cosmetically route the hoses while allowing enough slack to allow for the movement of the machine.



i) Run tractor hoses: (S/N PD1233 & Down)

- Attach hose fittings as shown below, tighten hoses to the bulkhead fitting, leave nut loose between the bulkhead and the hitch hose.

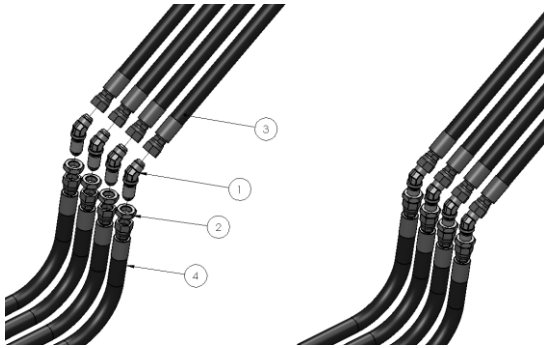

Figure 19 - Hitch to tractor hose connection

ITEM NO.	DESCRIPTION	QTY.
1	8MJBH-8MJ45	4
2	Bulkhead Nut	4
3	Tractor Hose	4
4	Hitch Hose	4

- Insert hoses into the hole in the hitch, and run back to the rear bulkhead plate. Connect to the fittings, then bolt the rear bulkhead plate on.

**NOTE: Keep track of which hose is which.**

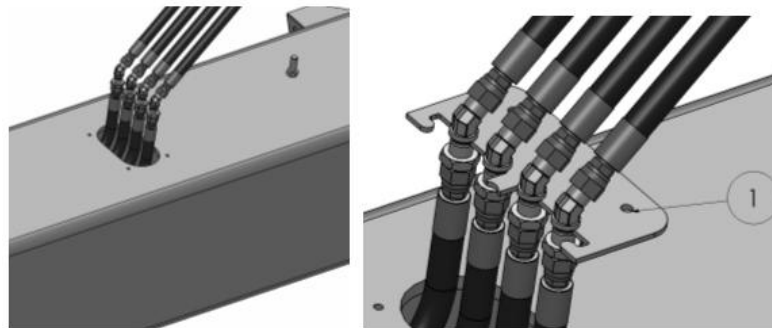
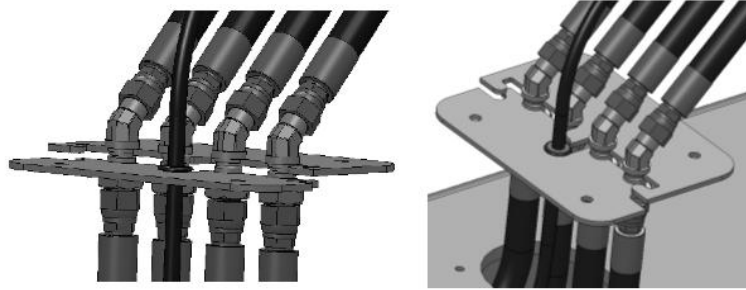

Figure 20 - Front bulkhead assembly

- Loosely place the hoses in the grooves in 23344 (1). The plate should go between the bulkhead flange and the nut.
- Place 23343 under 23344 in between the bulkhead flange and the nut so the bulkhead fitting is clamped between the semi-circles on the two plates. Slide the lower plate up until flush with the other plate. Tighten the nuts on the lower side.





- Bolt the assembled bulkhead plate to the hitch using 3/8 x 1" (13806) bolts.  
**NOTE: Do not do this step until after the electrical wiring is run.**

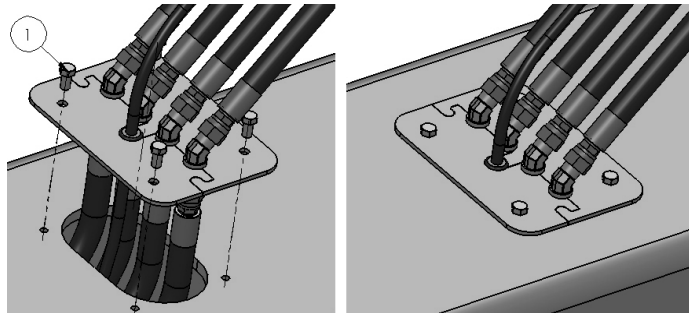

- Install pioneer fittings (17379) to the end of each hose and mark with heat shrink.
  - **Green 1"** runs to right tilt cylinder base/left tilt cylinder ram
  - **Green 2"** runs to right tilt cylinder ram/left tilt cylinder base
  - **Red 1"** runs to lift cylinder bases
  - **Red 2"** runs to lift cylinder rams

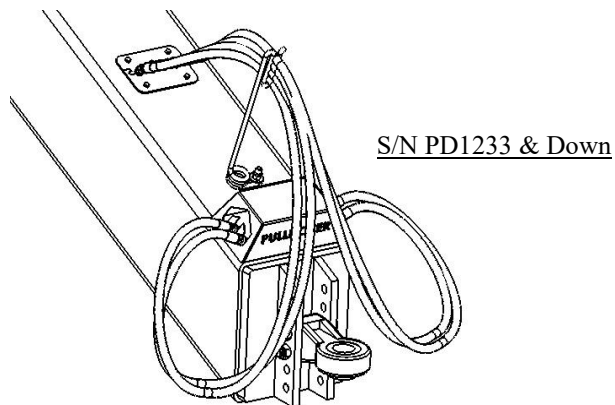

j) Run tractor hoses: **(Pulldozer S/N PD1234 & Up)**

- Attach hose fittings as shown below, tighten hoses to the bulkhead fitting, leave nut loose between the bulkhead and the hitch hose.

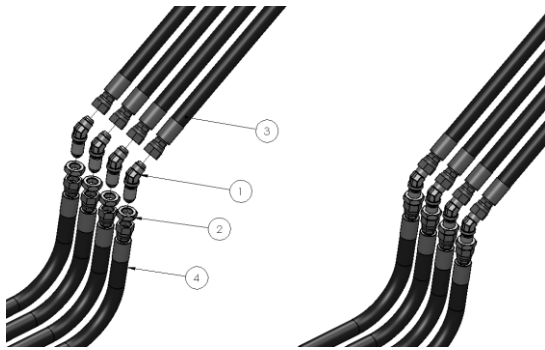

Figure 21 - Hitch to tractor hose connection

ITEM NO.	DESCRIPTION	QTY.
1	8MJBH-8MJ45	4
2	Bulkhead Nut	4
3	Tractor Hose	4
4	Hitch Hose	4

- Insert hoses into the hole in the hitch, and run back to the rear bulkhead plate. Connect to the fittings, then bolt the rear bulkhead plate on.

**NOTE: Keep track of which hose is which.**

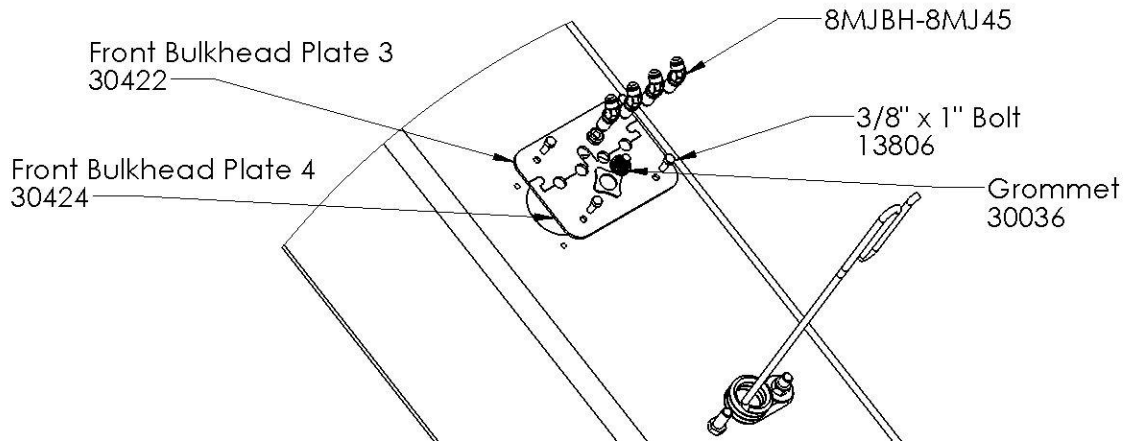

Figure 22 - Front bulkhead assembly

- Loosely place the hoses in the grooves in 30422 (1). The plate should go between the bulkhead flange and the nut. Make sure the hoses go out at a 45 degree towards the rear of the machine then loop to the front of the machine shown in the picture below:



- Place 30422 under 30424 in between the bulkhead flange and the nut so the bulkhead fitting is clamped between the semi-circles on the two plates. Slide the lower plate up until flush with the other plate. Tighten the nuts on the lower side.
  
- Bolt the assembled bulkhead plate to the hitch using 3/8 x 1" (13806) bolts.  
**NOTE: Do not do this step until after the electrical wiring is run.**
  
- Install pioneer fittings (17379) to the end of each hose and mark with heat shrink.
  - **Green 1"** runs to right tilt cylinder base/left tilt cylinder ram
  - **Green 2"** runs to right tilt cylinder ram/left tilt cylinder base
  - **Red 1"** runs to lift cylinder bases
  - **Red 2"** runs to lift cylinder rams
  
- k) Bolt the hydraulic hose hanger (34493) to the front hitch as shown, using a 3/4" x 5" bolt (10803) and a 3/4" nylon lock nut (10007). Install turnbuckle (14276) to hose hanger and mount. Attach top clamp (34507) of hose holder using: 5/16" chain (32168), two 1/2" x 1-1/2" bolts (10174), four 1/2" flat washers (11668), and two 1/2" nylon lock nuts (10241). Plastic hose clamps (21561) can be installed with tractor hydraulic hoses using the flat bottom hose holder plate (34506), two 5/16" nylon lock nuts (11815), and two 5/16" x 2-1/2" bolts (19115). If on an XL series Pulldozer, instead use: bottom hose holder plate (34520), one 5/16" x 2-1/2" bolt (19115), and one 5/16" x 4" (31837).



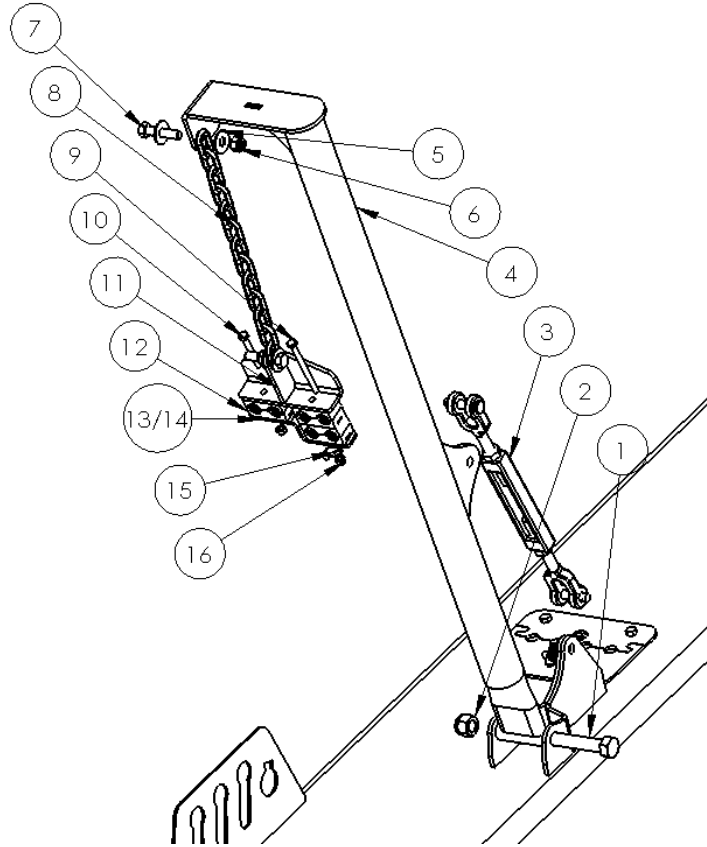

#	Description	Part #	QT
1	Bolt, 3/4" x 5"	10803	1
2	Nylon Lock Nut, 3/4"	10007	1
3	Turnbuckle	14276	1
4	Hydraulic Hose Hanger	34493	1
5	Flat washer, 1/2"	11668	4
6	Nylon Lock Nut, 1/2"	10241	2
7	Bolt 1/2" x 1-1/2"	10174	2
8	Hose Holder Chain (5/16")	32168	1
9	Bolt 5/16" x 4"	31837	0 (1 if XL series)
10	Bolt 5/16" x 2-1/2"	19115	2 (1 if XL series)
11	Hose Holder Top Clamp	34507	1
12	Plastic Hose Clamp	21561	4 (6 if XL series)
13	Bottom Hose Holder Plate	34520	0 (1 if XL series)
14	Bottom Hose Holder Plate (Straight)	34506	1 (0 if XL series)
15	Cable Clamp	13629	1
16	Nylon Lock Nut, 5/16"	11815	2

Figure 23-Hydraulic Hose Holder



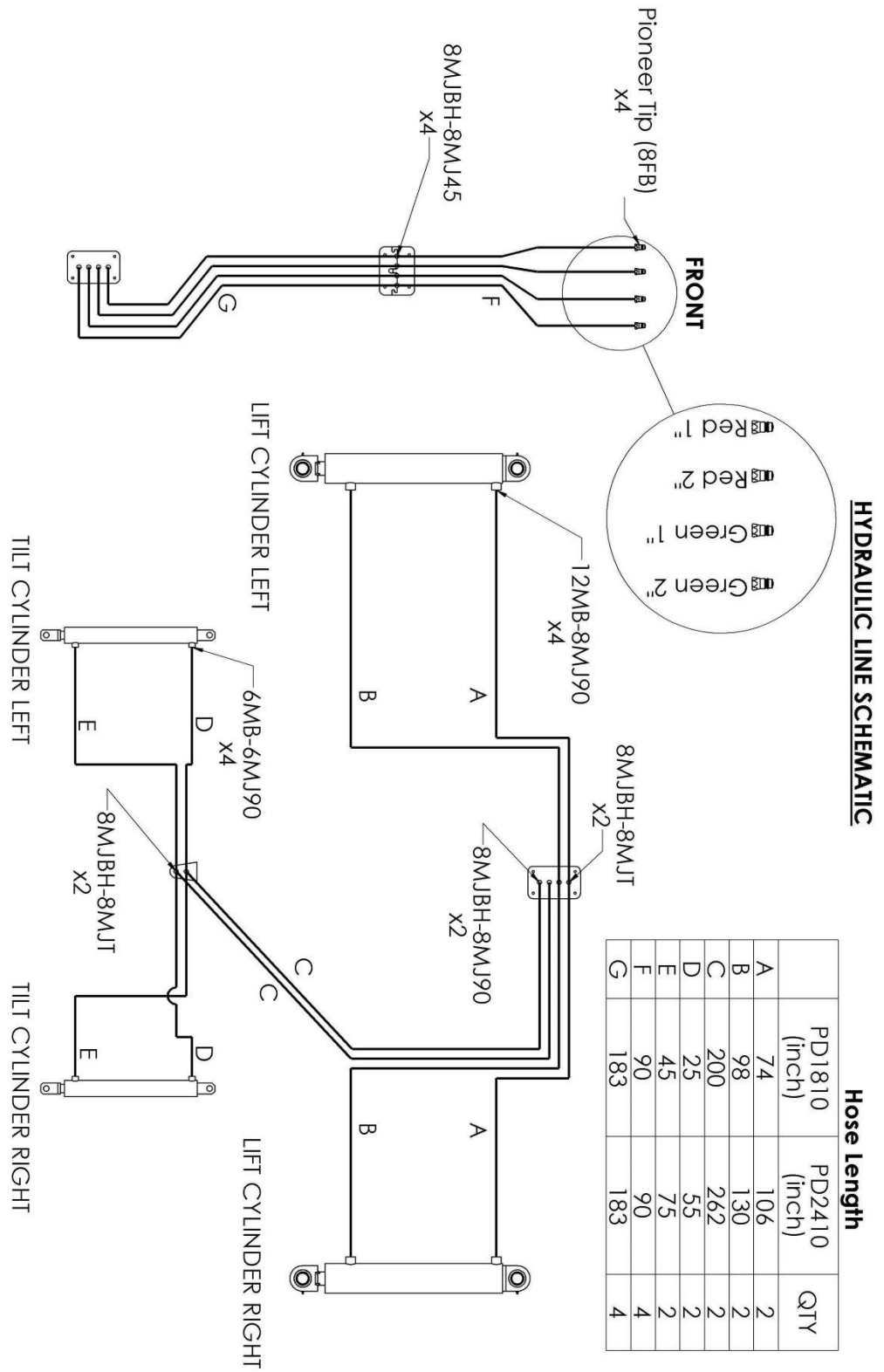

### 3.4. Electrical Assembly

#### Serial # PD1309 & Down

- a) Run main electrical cable (4-wire) through the hitch (see wiring diagram at end of section). It will run alongside the hydraulic lines, through the front bulkhead cover (using a grommet: 21428). Leave enough wire at the back for ease of making connections. Both bulkhead covers can then be installed.

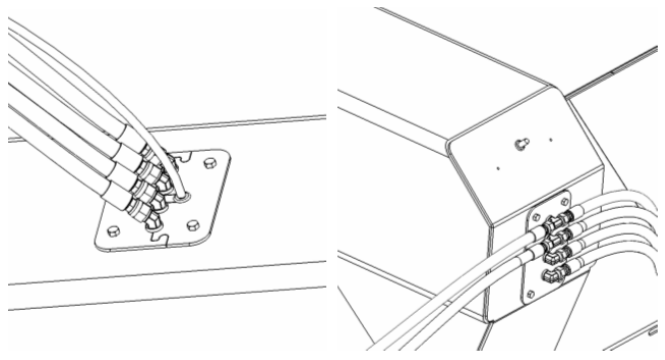

- b) Install 7-pin junction box (13668) to back of blade. First, a hole needs to be drilled in the junction box (see drawing) and then insert a grommet (23327) into it.

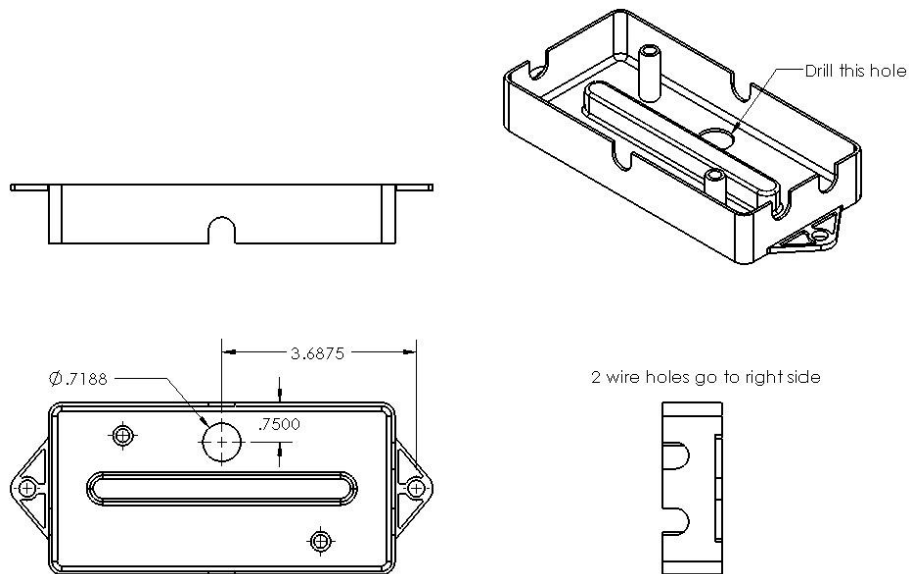

Run cable through the hole, and bolt the junction box to the back of the blade using two 1/4" x 1" bolts (11810).

Split the end of the cable and separate the four wires. Attach a blue ring connector (21455) to the end of each wire, and connect them to the posts (see wiring diagram).

Pull back any slack in the cable towards the front of the machine.



c) Connect the 7-pin trailer plug (12177) to the front of the machine as per the wiring diagram.

d) Attach each flasher light assembly to the blade using a 3/4" x 4-1/2" bolt (21460) and nylon lock nut (10007).

Install two cable clamps along the top of the blade on each side, and attach using 3/8" x 3/4" bolts (11816) and serrated flange nuts (10271).

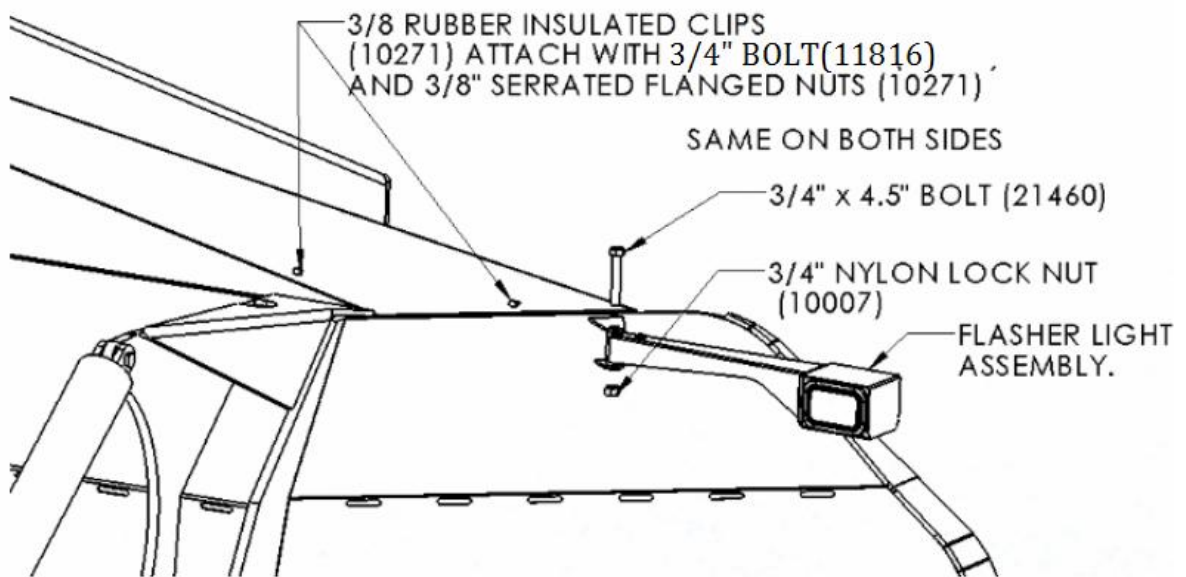
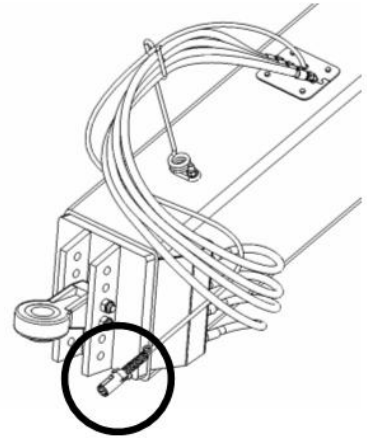
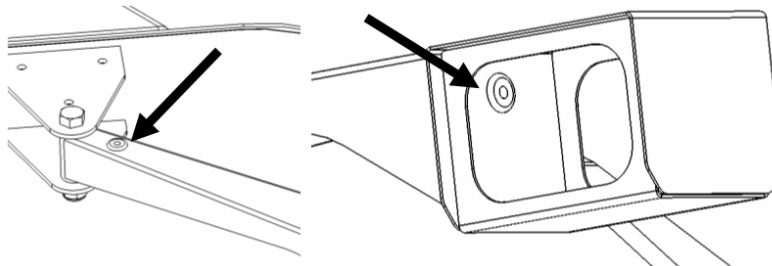

Figure 23 - Flasher light assembly

Install 2 grommets (21439) into each arm as shown.



e) Route the flasher electrical lines to the box and wire them in as per schematic.



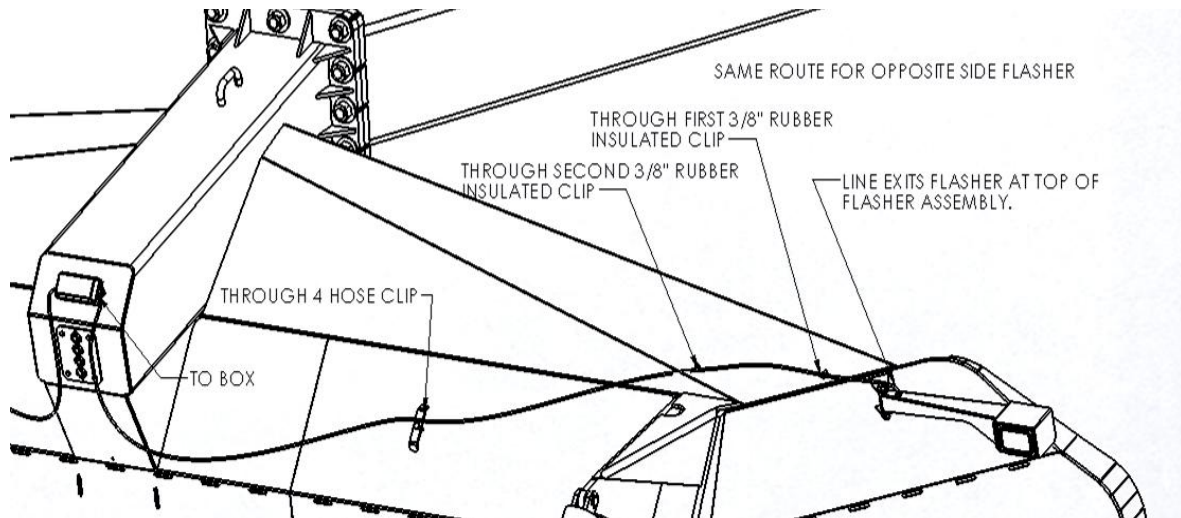

Figure 24 - Flasher electrical routing

- f) Route the tail lights electrical line and wire it in to the box as per schematic. Install a grommet (21439) to the bottom of the right tail light bracket. The wire runs alongside the hydraulic lines on the main frame. Run a second wire between the tail lights through the main frame top tube. Install cap on junction box.

- g) Install and wire all 6 lights (2 red - 21419, 4 amber - 21420). A 3 wire, 90 degree pigtail (21422) should be plugged into the back of each light. A rubber grommet (21421) must also be placed around each light.

Wire each pigtail to the cables as per the schematic. Solder and apply heat shrink to each joint to ensure a good connection.

Shove each light into the holes until the grommet is properly seated. It should be a tight fit.

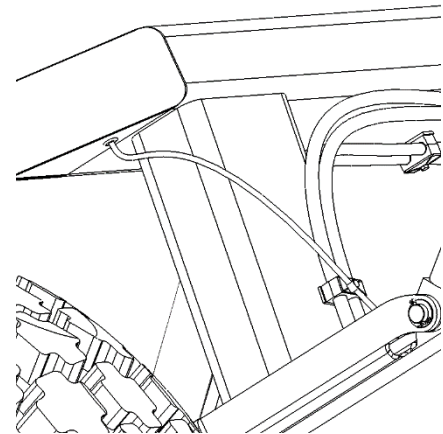

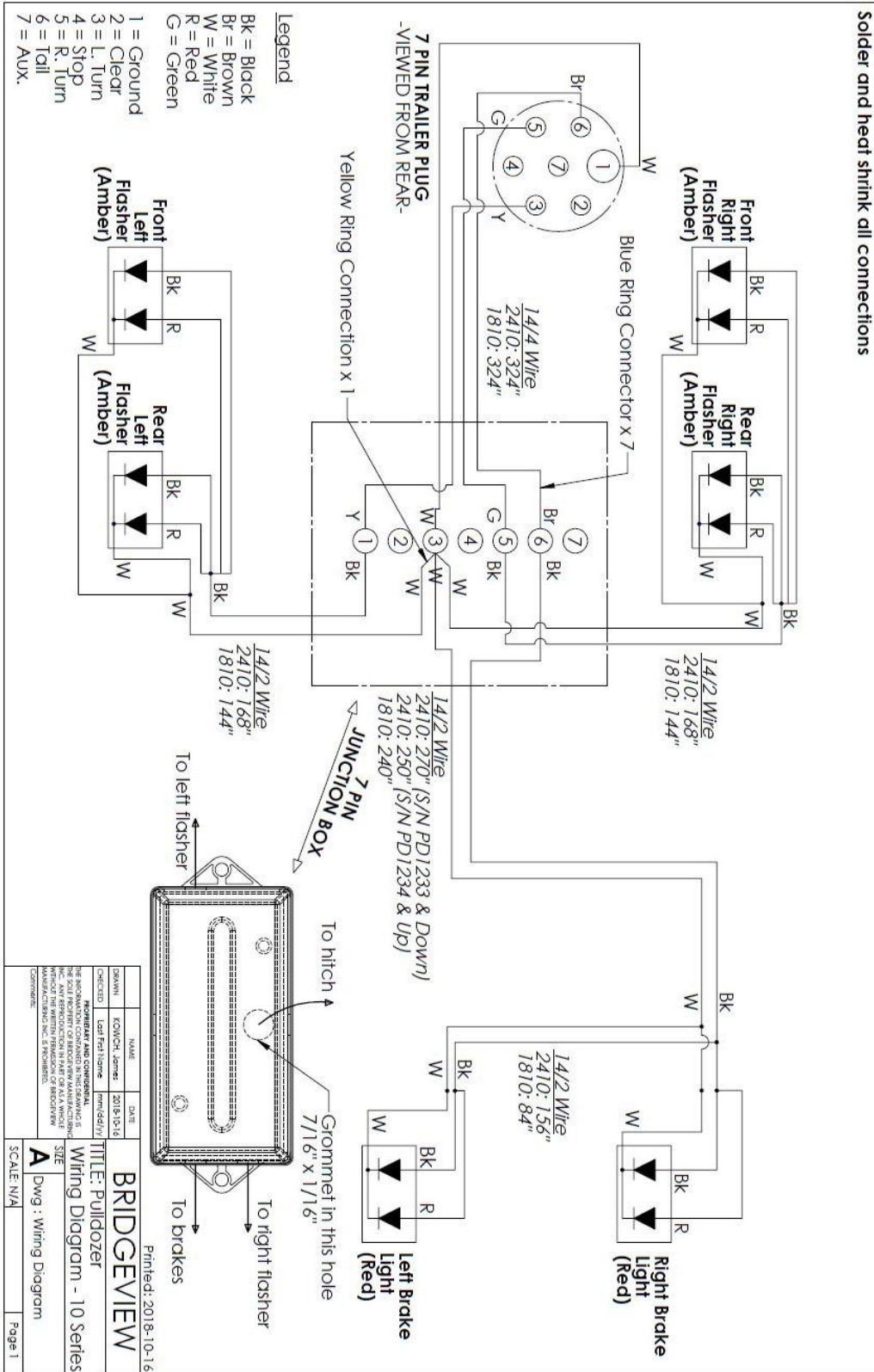

NAME	DATE
KOVICH, James	2018-10-16
LAST FIRST NAME	MM/DD/YY
NONREPEATABLE AND CONFIDENTIAL THE INFORMATION CONTAINED IN THIS DRAWING IS THE PROPERTY OF BRIDGEVIEW MANUFACTURING INC. ANY REPRODUCTION IN PART OR AS A WHOLE WITHOUT THE WRITTEN PERMISSION OF BRIDGEVIEW MANUFACTURING INC. IS PROHIBITED.	
TITLE: Pulldozer Wiring Diagram - 10 Series	
SIZE	SCALE: N/A
A	Page 1



**Serial # PD1310 & Up**

- a) Run main electrical cable (4-wire) through the hitch (see wiring diagram at end of section). It will run alongside the hydraulic lines, through the front bulkhead cover (using a grommet: 21428 & 23327 for the rear bulkhead).

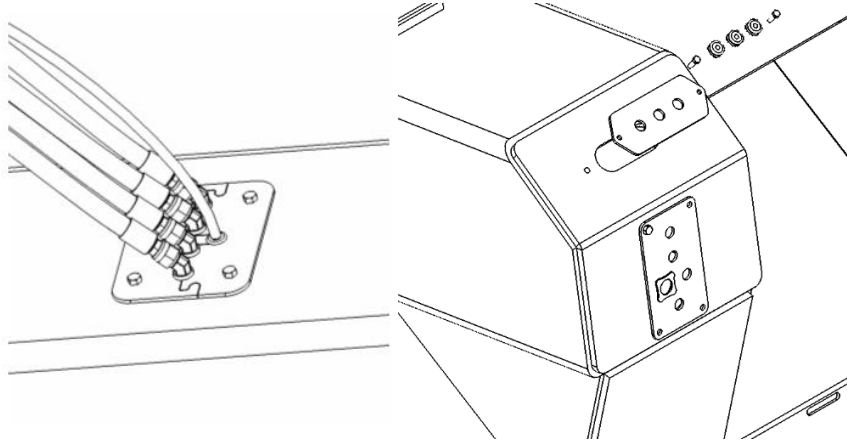

- h) Connect the 7-pin trailer plug (12177) to the front of the machine as per the wiring diagram.

- i) Attach each flasher light assembly to the blade using a 3/4" x 4-1/2" bolt (21460) and nylon lock nut (10007).

Install two cable clamps along the top of the blade on each side, and attach using 3/8" x 3/4" bolts (11816) and serrated flange nuts (10271).

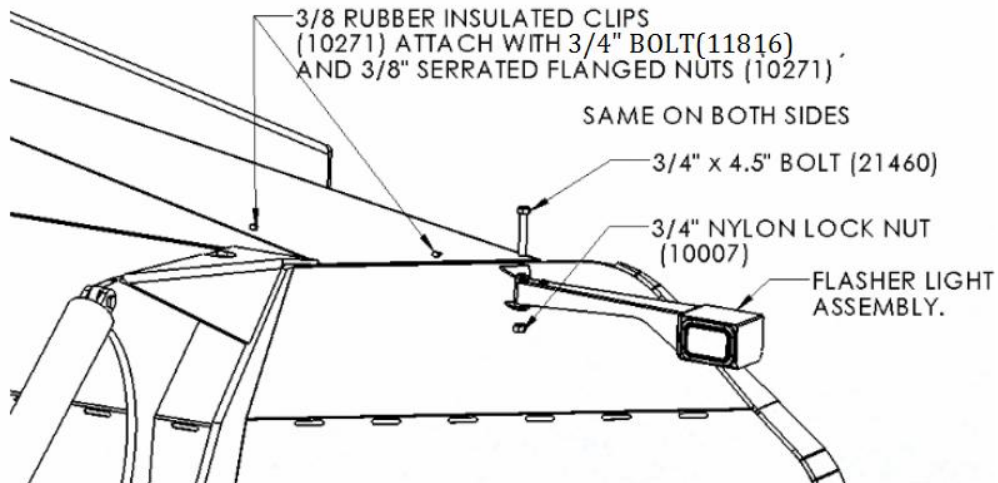
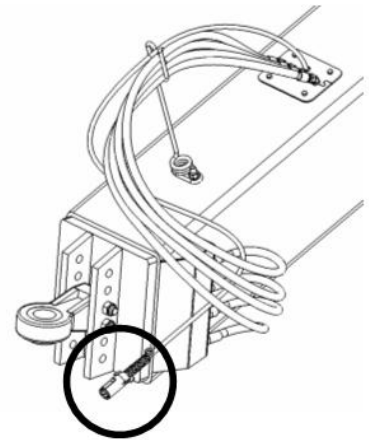
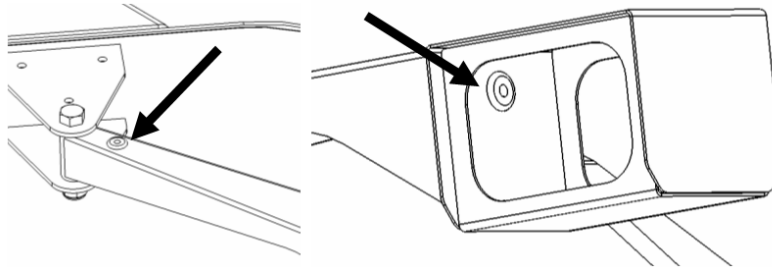

Figure 25 - Flasher light assembly



Install 2 grommets (21439) into each arm as shown.



- j) Route the flasher electrical lines to the flasher light assembly and wire them in as per schematic.
- k) Route the tail lights electrical line and install a grommet (21439) to the bottom of the right tail light bracket. The wire runs alongside the hydraulic lines on the main frame.
- l) Install and wire all 6 lights (2 red - 21419, 4 amber - 21420). A 3 wire, 90-degree pigtail (21422) should be plugged into the back of each light. A rubber grommet (21421) must also be placed around each light.

Shove each light into the holes until the grommet is properly seated. It should be a tight fit.

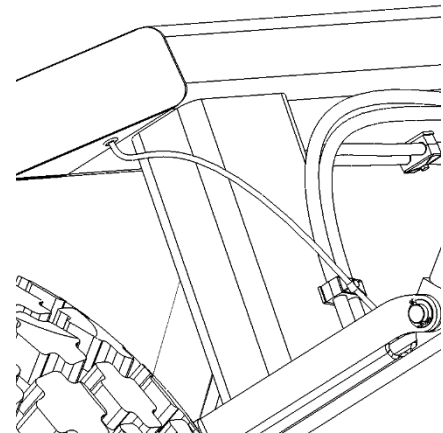

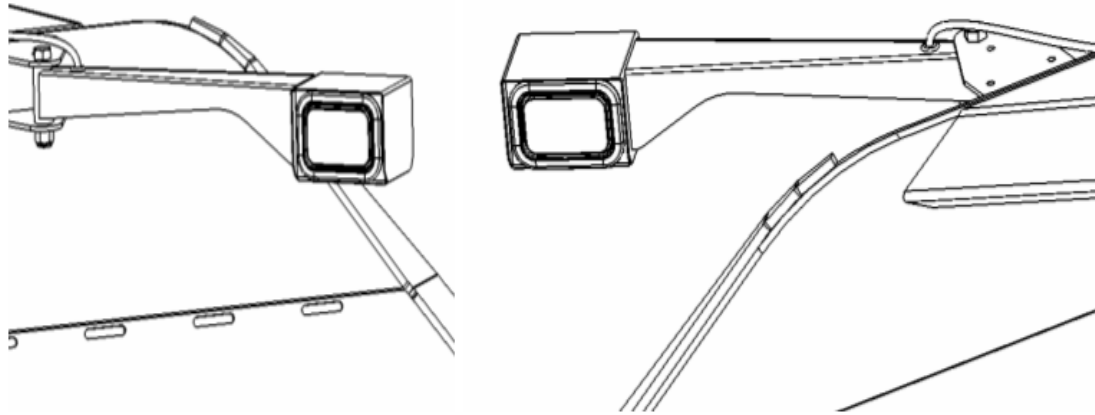
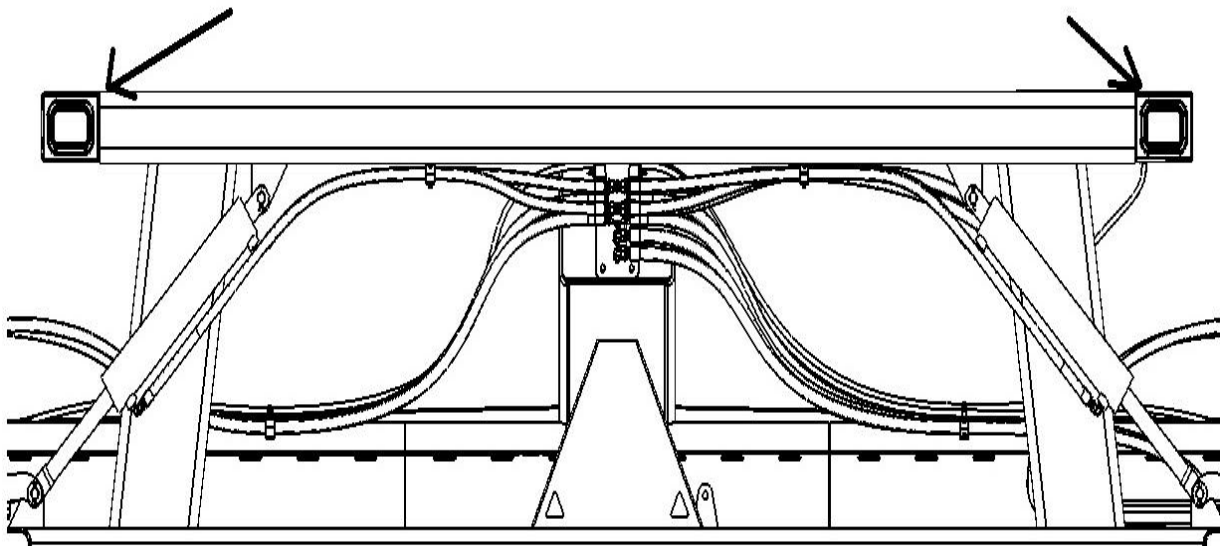

Figure 26 - Amber light locations



**2410 S/N PD1234 & Up**

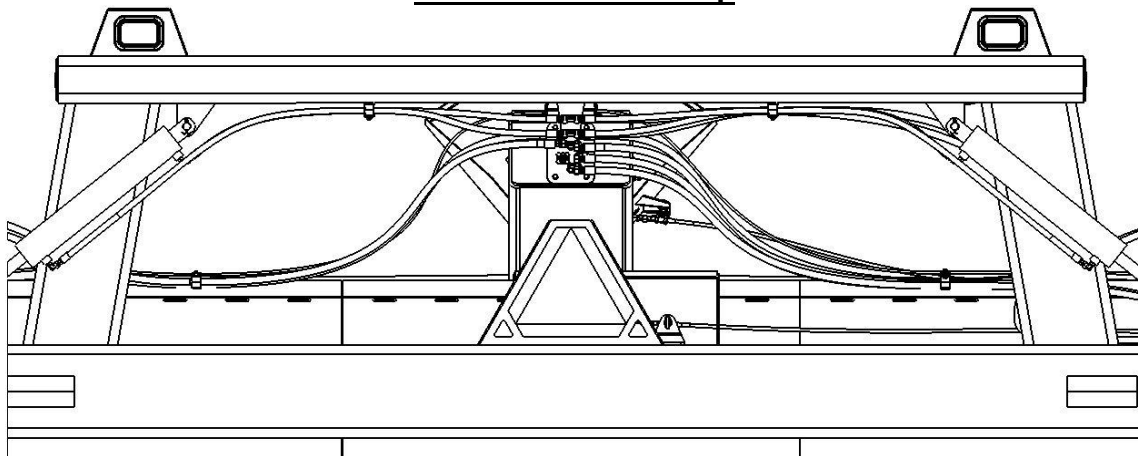
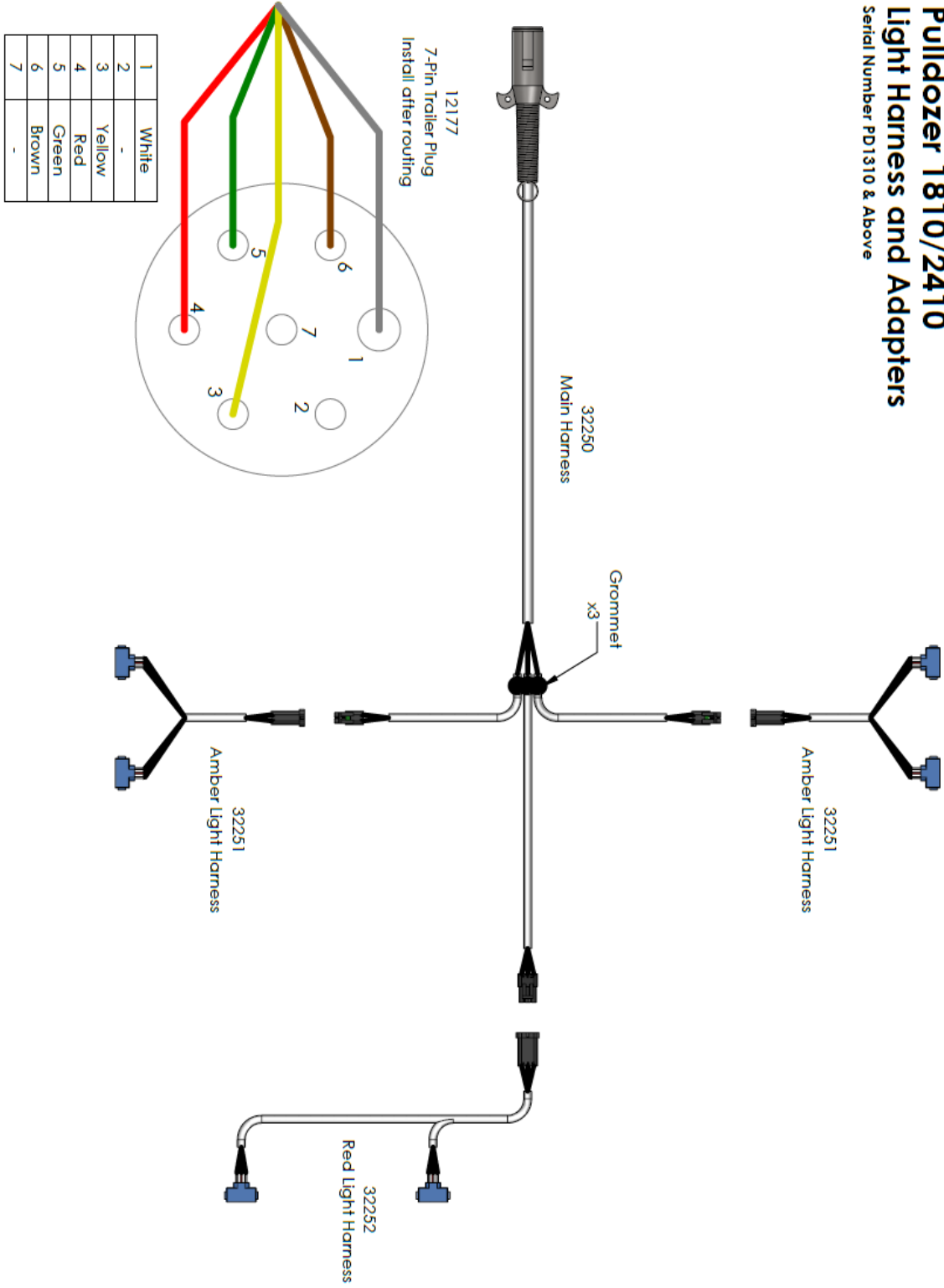

Figure 27 - Red light locations



**Pulldozer 1810/2410**  
**Light Harness and Adapters**  
 Serial Number PD1310 & Above



### 3.5. Miscellaneous

#### Grease Zerks:

There are 13 grease zerks installed on the Pulldozer that require grease before operation. There are six located where the main frame attaches to the blade (1,2), one on each end of the lift cylinders (3,4), one where the axle attaches to the main frame (5), and two on the articulating hitch(6). There are also 2 more on the trencher pivot (7) if installed on your machine.

**Make sure all joints have sufficient grease.**

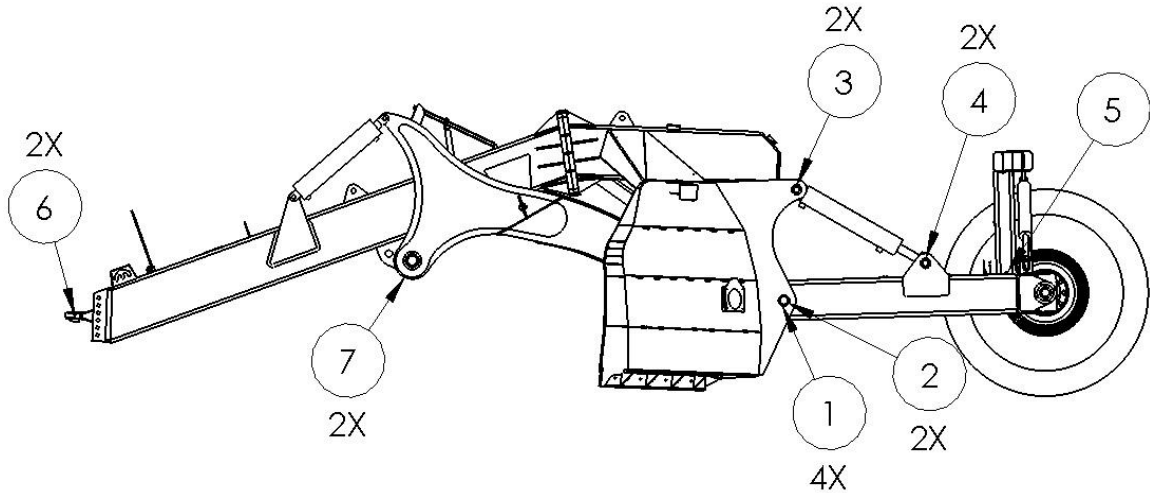

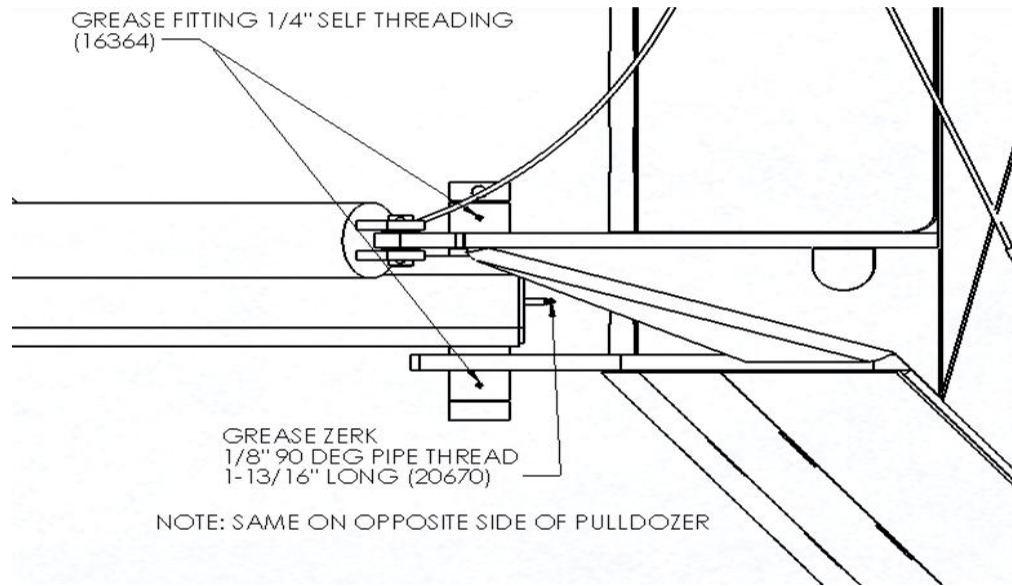

Figure 28 - Blade pin grease zerks

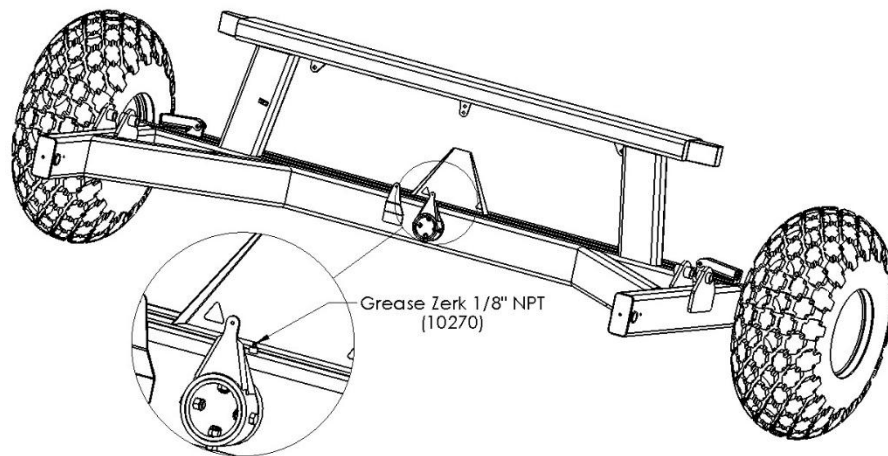

Figure 29 - Axle pivot grease zerk

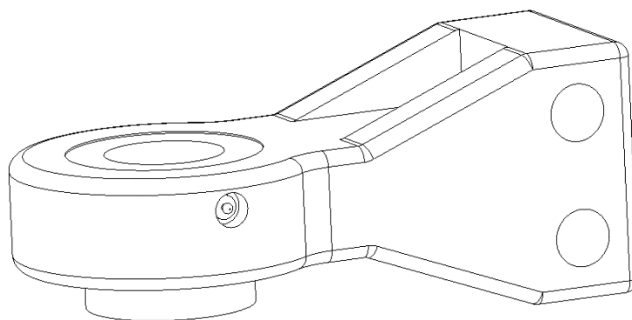

Figure 30 - Articulating hitch grease zerks (x2)

**Scraper Blades:**



After hooking up the Pulldozer to the tractor. Lift the blade off the ground and lock it in place. Then attach two (1810) or three (2410) 6 foot cutting edges (20430) and two 4 foot cutting edges (20428) using the scraper blade bolts (1810 x 45 – 2410 x 57) (20448) and 3/4" nuts (1810 x 45 – 2410 x 57) (20606). Attach the 4' sections to the wings first, then the 6' sections to the center.

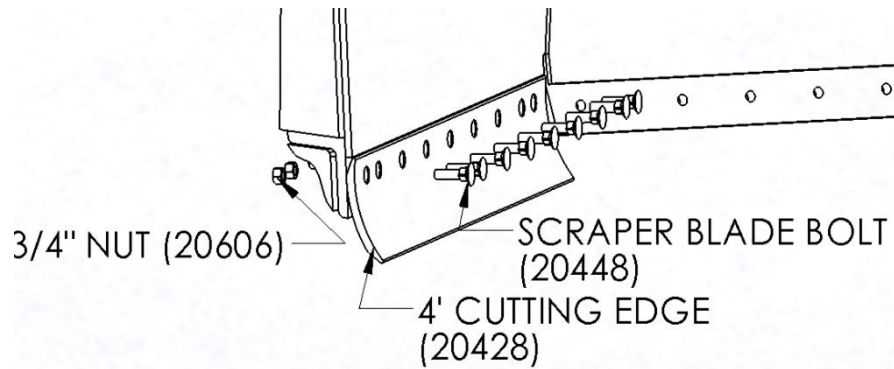

Figure 31 - 4 Foot scraper blade attachment

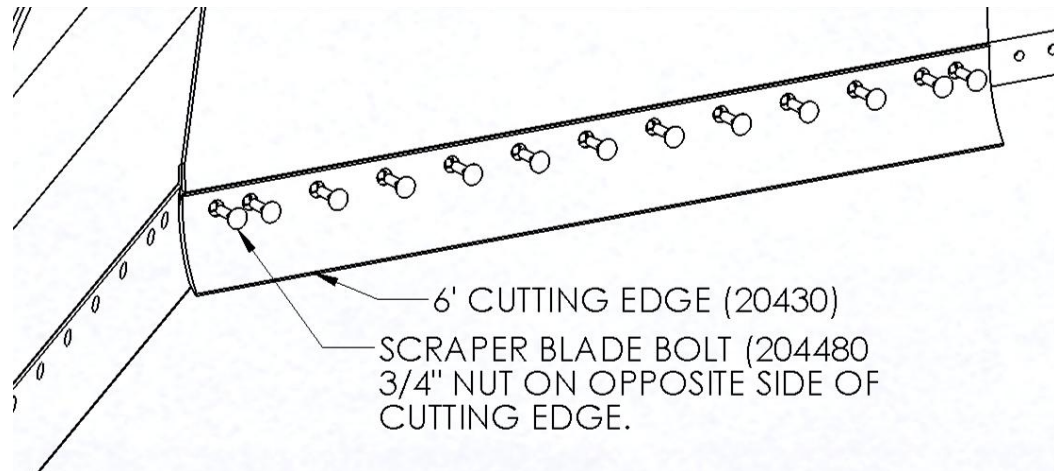

Figure 32 - 6 Foot scraper blade attachment

### Operator's Manual & Serial Number:

Install the manual holder box (22409) to the back of the blade using 1/4" x 3/4" bolts (11809), flat washers (11666) and serrated flange nuts (11812).

Install the serial number plate above the manual holder using 1/8" pop rivets.



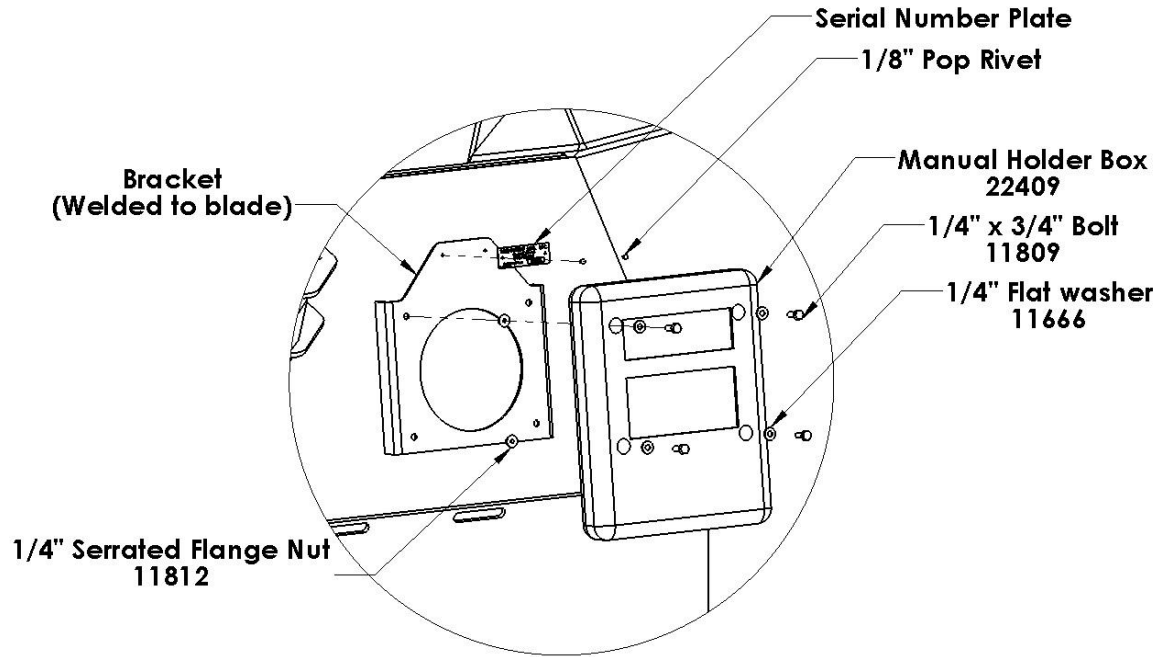

**Angle Indicator (S/N 24986-up, PD1000-up):**

Install the angle indicator bracket (31171) and the laser mount plate (24010) to the top of the blade using six 3/8" x 1" bolts (13806) and serrated flange nuts (10271).

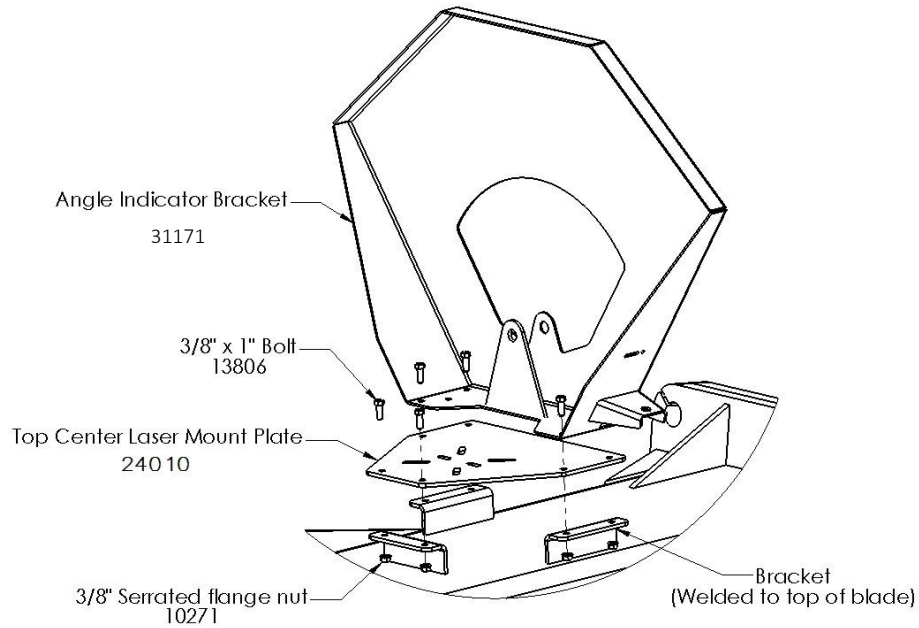

Assemble the angle indicator and install the cable to the top end.

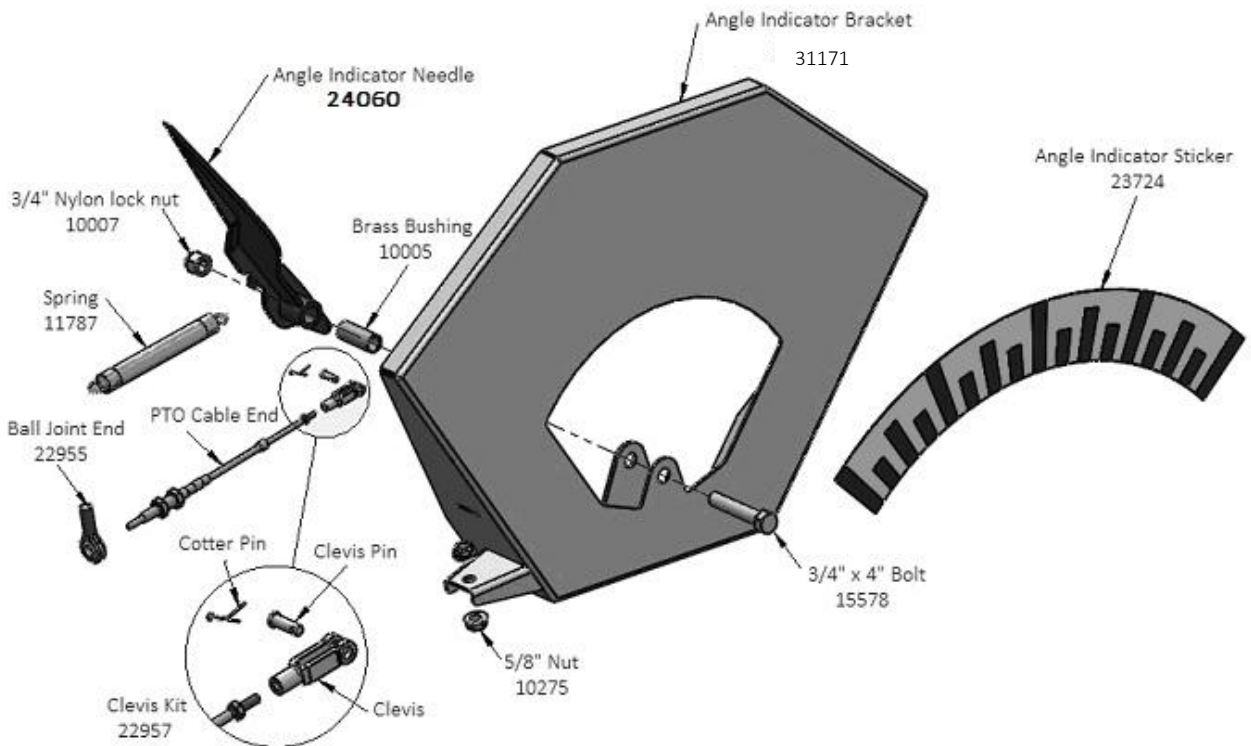

- Center and install decal (23724) onto indicator bracket (31171)
- Insert brass bushing (10005) into indicator needle (24060)
- Install arm onto bracket using brass bushing, 3/4" x 4" bolt (15578) and 3/4" lock nut (10007). DO NOT OVERTIGHTEN - Arm must swivel freely
- Install one end of the PTO cable through the slotted hole in the bracket and insert the ball joint (22955) into the bracket and tighten in place using two 5/8" nuts (10275)
- Install the clevis end of the cable (22957) to the arm using the supplied pin and cotter pin. NOTE: There are two different holes, depending on which size machine you have.
- Install one end of the spring (11787) into the needle, then through the clip on the bracket
- Leave the clevis jam nut loose until the final adjustment is complete



24 Foot

18 Foot

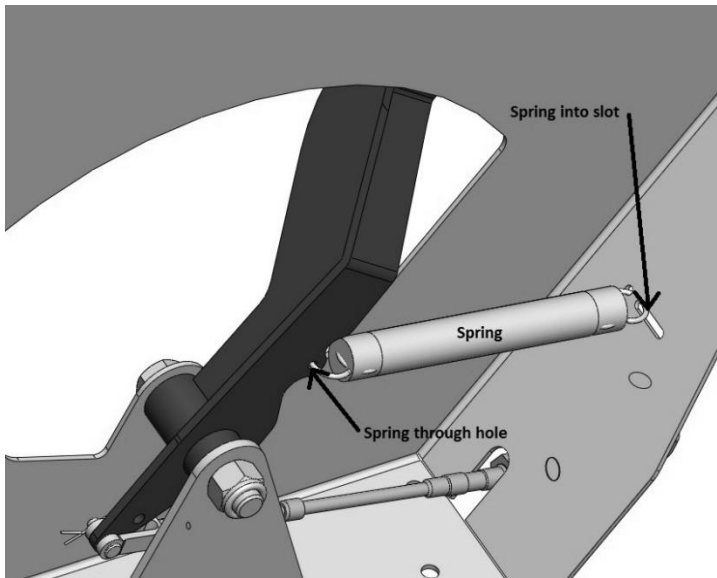

**Angle Indicator (S/N 24901-24985):**

Install the angle indicator bracket (22908) to the top of the blade using six 3/8" x 3/4" bolts ( ) and serrated flange nuts (10271).

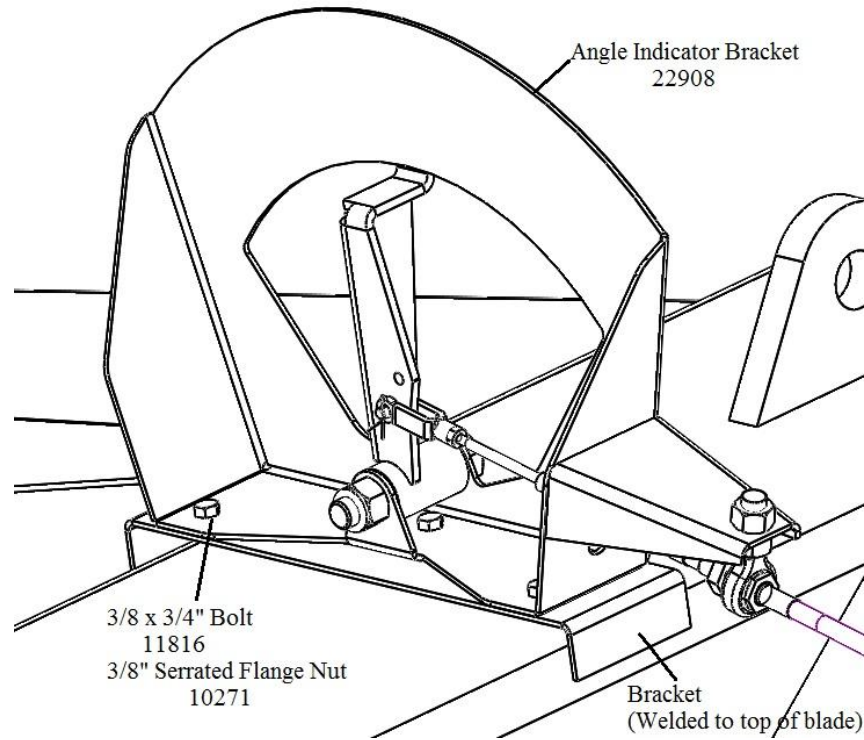

Assemble the angle indicator and install the cable to the top end.

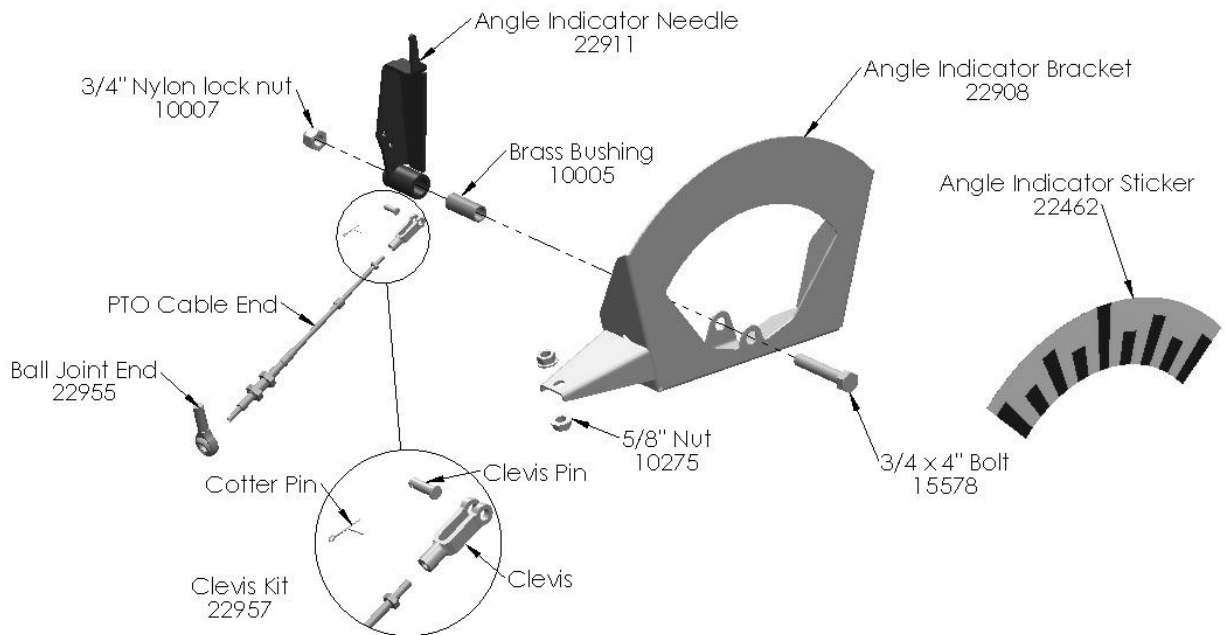

- Center and install decal (22462) onto indicator bracket (22908)
- Insert brass bushing (10005) into indicator needle (22911)
- Install arm onto bracket using brass bushing, 3/4" x 4" bolt (15578) and 3/4" lock nut (10007). DO NOT OVERTIGHTEN - Arm must swivel freely
- Install one end of the PTO cable through the slotted hole in the bracket and insert the ball joint (22955) into the bracket and tighten in place using two 5/8" nuts (10275)
- Install the clevis end of the cable (22957) to the arm using the supplied pin and cotter pin. NOTE: There are two different holes, depending on which size machine you have.
- Leave the clevis jam nut loose until the final adjustment is complete

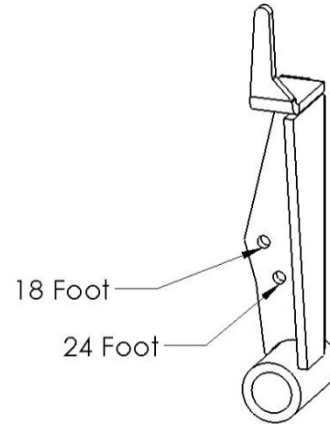

**Angle Indicator:**

Loosely route the cable alongside the hydraulic hoses towards the back of the machine. Install the eyeball and clevis of the cable as per the top side.

2410	20 ft Cable	23307
1810	15ft Cable	22958

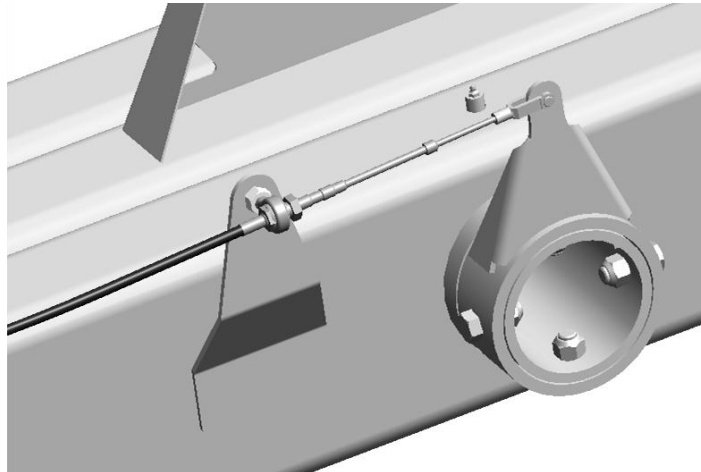

**Angle Indicator (2410 S/N PD1324 & Up):**

Loosely route the cable alongside the hydraulic hoses towards the back of the machine. Install the eyeball and clevis of the cable as per the top side.

2410                      20 ft. Cable                      23307

**2410 S/N PD1234 & Up**

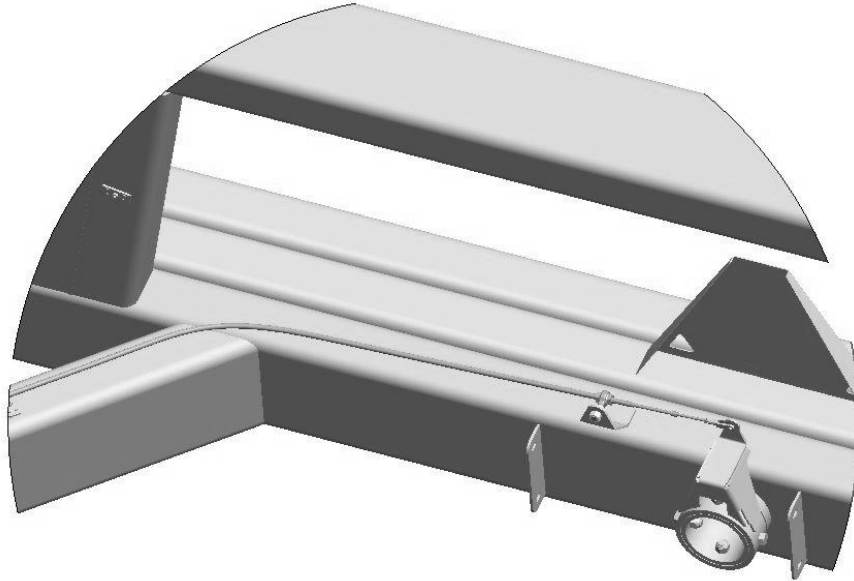

Clamp the cable to the hydraulic hose holders on the main frame using a rubber insulated cable clamp (13629).

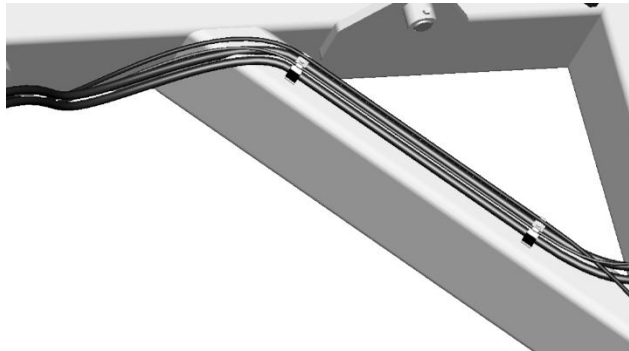

Along the top of the blade, install a clamp to tie the cable down. Use a 3/8" x 3/4" bolt (11816) and a serrated flange nut (10271).

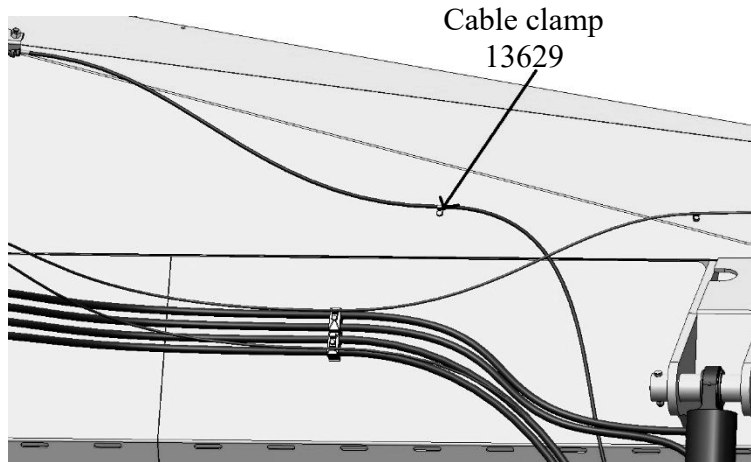

If the indicator needle does not read "center" when the blade is perfectly level, it can be adjusted by loosening the jam nut on one of the clevises and threading the clevis either in or out. Start off with the dimension shown below then adjust accordingly. Tighten the jam nuts when finished adjustment.

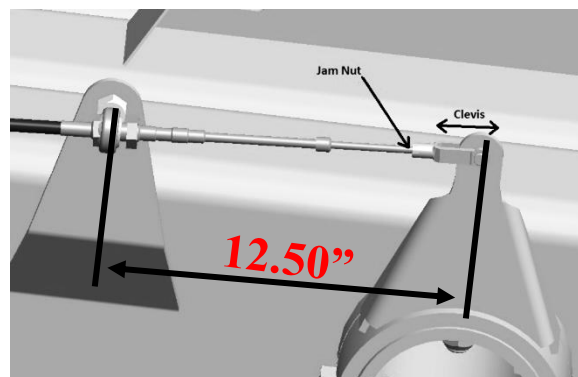
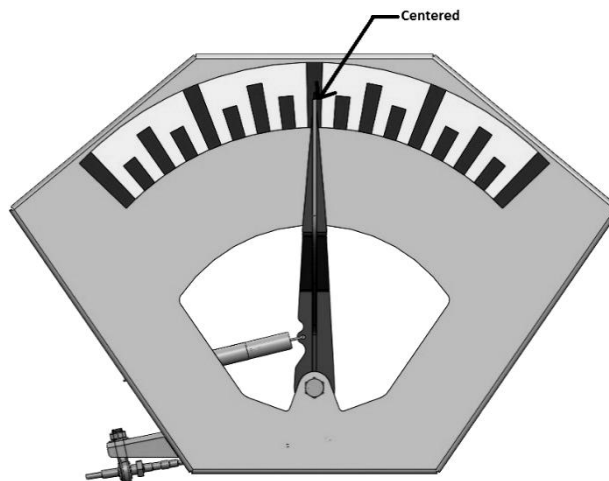

### 3.6. Trencher Option

*NOTE: For machines with the optional trencher, the hitch section is replaced with a special hitch. All other steps remain the same.*

*All following steps can be done at any time after the hitch is installed*

- a) Place the trencher arm underneath of the hitch, then lift it up into place and insert the pin (22099). Lock the pin in place using two 3/4" x 5" bolts (10803) and Stover lock nuts (11823). Lastly, install two 1/4" self-tapping grease zerks (16364) into the holes in the pivot pipe. Fill with grease until pipe is full.

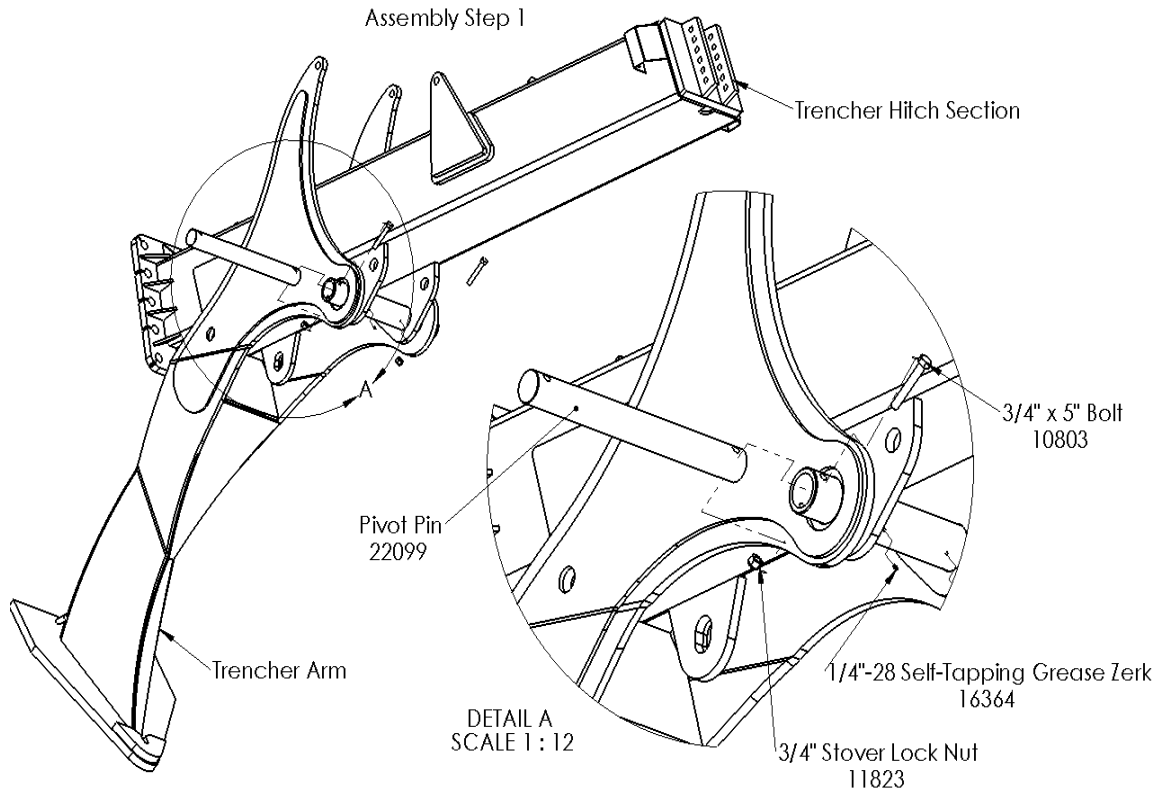

*Figure 33 - Trencher install*



- b) Place the indicator sticker (22209 - 18ft, 22078 - 24ft) onto the depth indicator bracket (27200) with the arrow pointing up. Then install the bracket to the tabs on the top of the hitch using four 3/8" x 1" carriage bolts (15718) and serrated flange nuts (10271).

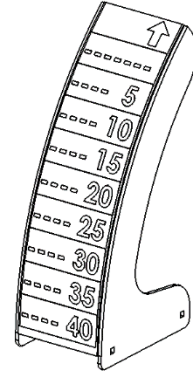

- c) Install the depth indicator arm (22137) to the tabs on the top of the hitch using a 1/2" x 3-1/4" bolt and nylon lock nut. The arm should pivot freely.

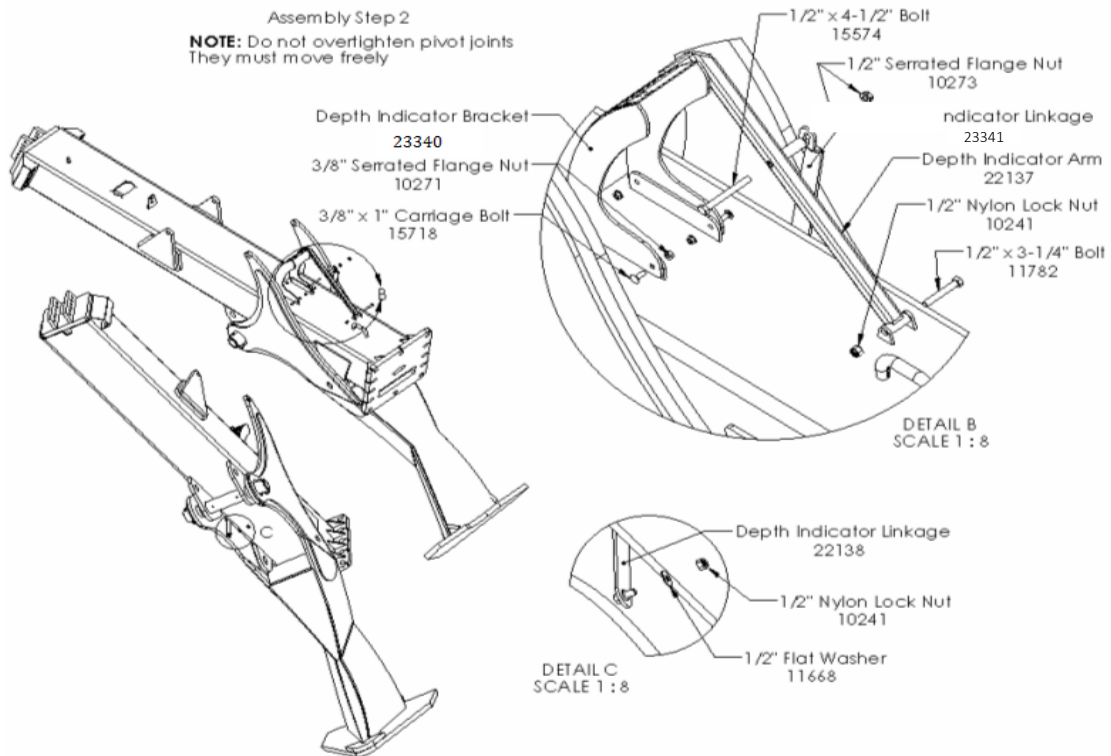
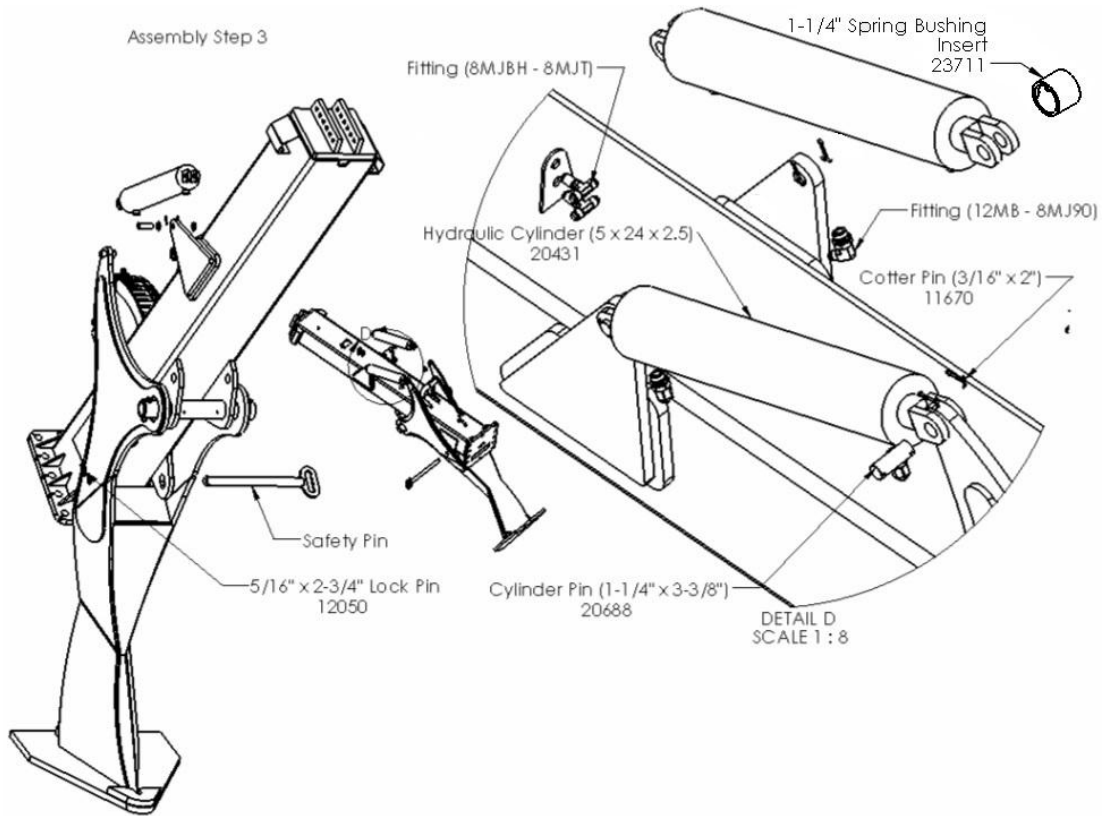

Figure 34 - Depth indicator assembly

- d) Install the depth indicator linkage (23341) to the welded on bolt on the ditcher (bushing end) using a 1/2" flat washer (11668) and nylon lock nut (10241). Install the other (slotted) end to the indicator arm using a 1/2" x 4-1/2" bolt (15574) and two serrated flange nuts (10273) to clamp the linkage. Make sure that the arm can still pivot up and down freely. The position within the slot will be set later.



- e) Install 5" x 24" hydraulic cylinders (20431) with the ram on the ditcher side and the ports down. Secure at both ends with a 1-1/4" cylinder pin (20688) and two 3/16" cotter pins (11670).



- f) Install 12MB - 8MJ90 fittings to each cylinder port, facing inwards and towards the front of the machine. Install two 8MJBH - 8MJT bulkhead tee fittings to the plate as shown, with the "tee" side towards the cylinders.



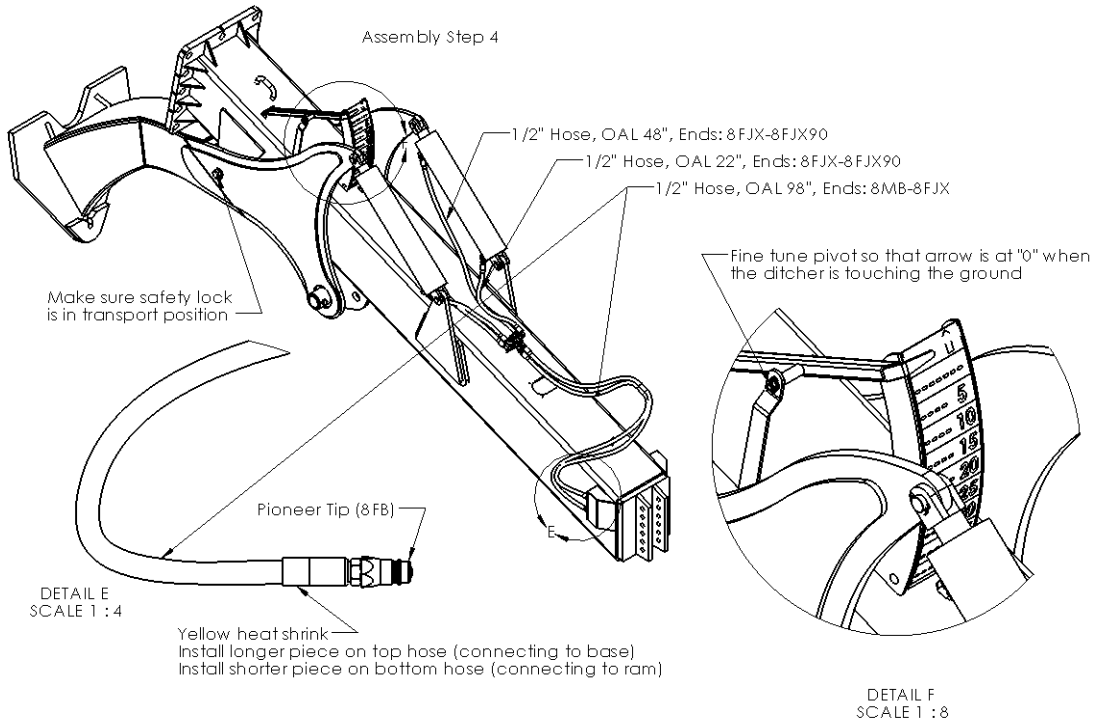

- g) Run the hydraulic hoses. Two 22" hoses run from the top bulkhead fitting to the base end of the cylinders, and two 48" hoses run from the bottom bulkhead fitting to the ram end of the cylinders. NOTE: The 90 degree ends connect to the bulkhead. Finally, two 98" hoses run to the hitch of the machine. Install pioneer ends (8FB) to each hose, and yellow heat shrink marker (as shown).
- h) Connect a tractor and charge the hydraulics. With the blade and the trencher tip both touching the ground, set the depth indicator to read "0". Lift the trencher into transport position and insert the safety lock (22136) and the lock pin (12050).



**3.7. Decals****DECAL LIST:****All Pulldozers:**

12228	Slow Moving Vehicle Sign	1
23724	Angle Indicator Decal (2013)	1
28383	Red Reflector (2" x 9")	4
28384	Yellow Reflector (2" x 9")	8
28385	Fluorescent Orange (2" x 9")	4
33135	Pulldozer Hydraulic Hose Decal	1

**"Red/Green Option"**

20938	FRONT BARRICADE LEFT	"FIST ///"	RED
20939	FRONT BARRICADE RIGHT	"FIST ///"	RED
20940	WHEAT FIST LEFT	"FIST ///"	RED
20941	WHEAT FIST RIGHT	"FIST ///"	RED
21604	FRONT BARRICADE LEFT	"FIST ///"	GREEN
21605	FRONT BARRICADE RIGHT	"FIST ///"	GREEN
21606	WHEAT FIST LEFT	"FIST ///"	GREEN
21607	WHEAT FIST RIGHT	"FIST ///"	GREEN



**Model-Specific:**

		"1810"	
23152	REAR AXLE 1810	"//// PULLDOZER 1810 ////"	RED
23153	RIGHT HITCH, 1810	"FIST PULLDOZER 1810 \\\\"	RED
23154	LEFT HITCH, 1810	"//// PULLDOZER 1810 FIST"	RED
23157	REAR AXLE 1810	"//// PULLDOZER 1810 ////"	GREEN
23155	RIGHT HITCH, 1810	"FIST PULLDOZER 1810 \\\\"	GREEN
23156	LEFT HITCH, 1810	"//// PULLDOZER 1810 FIST"	GREEN
		"2410"	
23142	REAR AXLE 2410	"//// PULLDOZER 2410 ////"	RED
23140	RIGHT HITCH, 2410	"FIST PULLDOZER 2410 \\\\"	RED
23141	LEFT HITCH, 2410	"//// PULLDOZER 2410 FIST"	RED
23145	REAR AXLE 2410	"//// PULLDOZER 2410 ////"	GREEN
23144	RIGHT HITCH, 2410	"FIST PULLDOZER 2410 \\\\"	GREEN
23143	LEFT HITCH, 2410	"//// PULLDOZER 2410 FIST"	GREEN
		"1810XL"	
23163	REAR AXLE 1810XL	"//// PULLDOZER 1810XL ////"	RED
23161	RIGHT HITCH, 1810XL	"FIST PULLDOZER 1810XL \\\\"	RED
23162	LEFT HITCH, 1810XL	"//// PULLDOZER 1810XL FIST"	RED
23158	REAR AXLE 1810XL	"//// PULLDOZER 1810XL ////"	GREEN
23159	RIGHT HITCH, 1810 XL	"FIST PULLDOZER 1810XL \\\\"	GREEN
23160	LEFT HITCH, 1810XL	"//// PULLDOZER 1810XL FIST"	GREEN
22209	DEPTH INDICATOR DECAL - 18 FOOT		
		"2410XL"	
23146	REAR AXLE 2410XL	"//// PULLDOZER 2410XL ////"	RED
23148	RIGHT HITCH, 2410XL	"FIST PULLDOZER 2410XL \\\\"	RED
23147	LEFT HITCH, 2410XL	"//// PULLDOZER 2410XL FIST"	RED
23149	REAR AXLE 2410XL	"//// PULLDOZER 2410XL ////"	GREEN
23150	RIGHT HITCH, 2410XL	"FIST PULLDOZER 2410XL \\\\"	GREEN
23151	LEFT HITCH, 2410XL	"//// PULLDOZER 2410XL FIST"	GREEN
22078	DEPTH INDICATOR DECAL - 24 FOOT		



**INSTALLATION:**

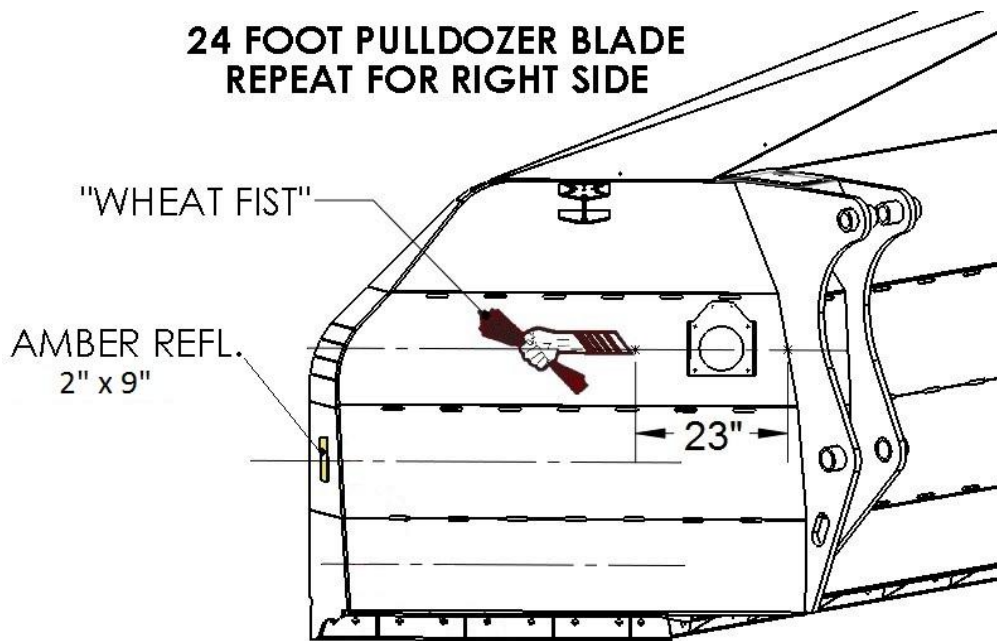
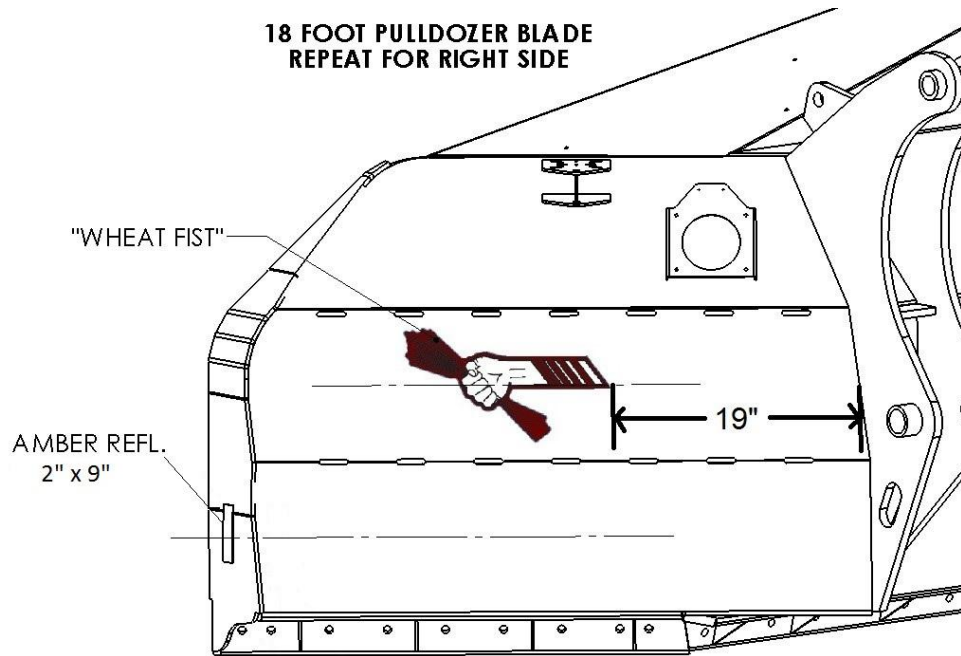



**2410 Main Frame Reflector**

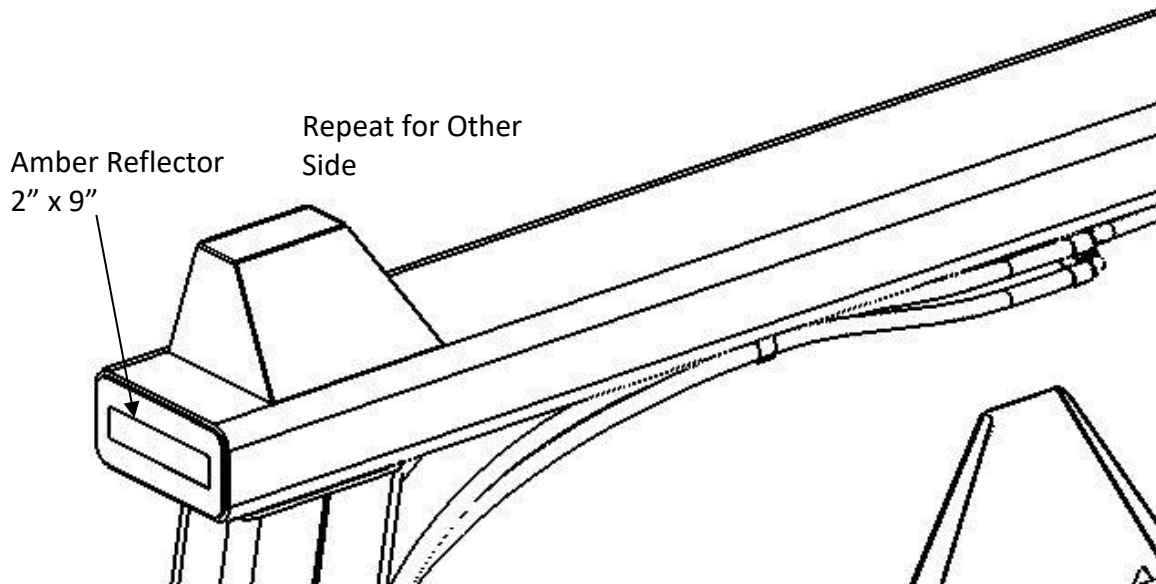

**1810 Main Frame Reflector**

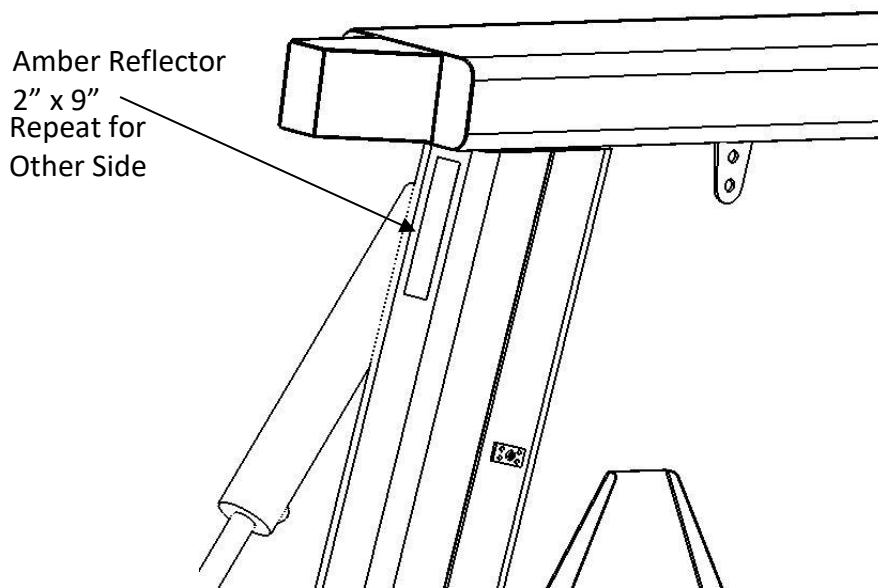

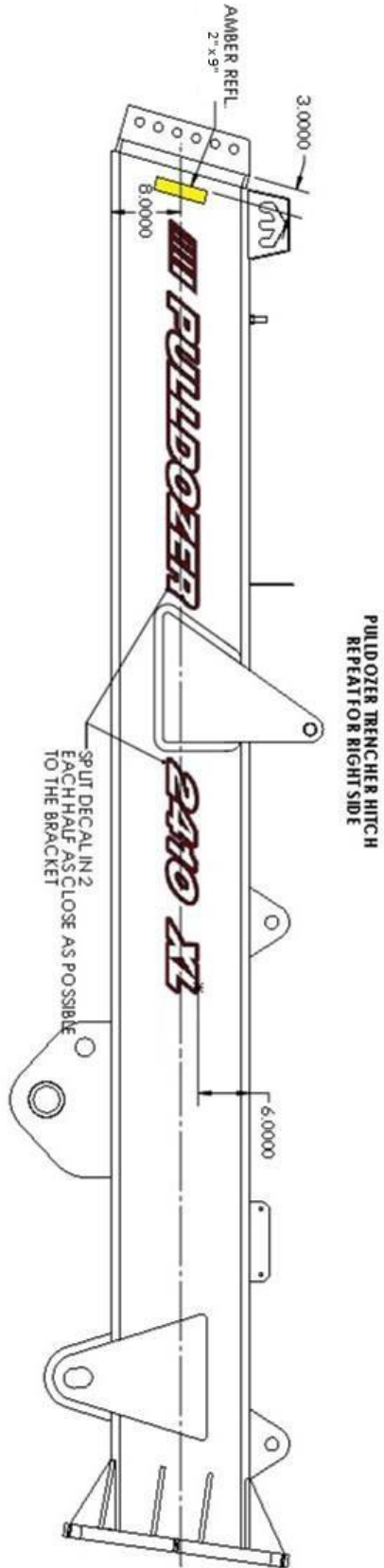
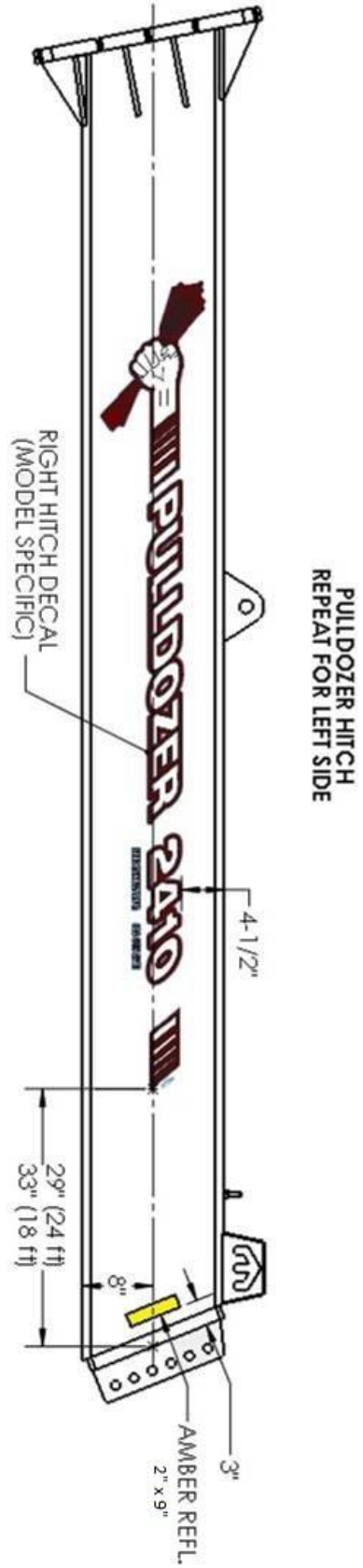

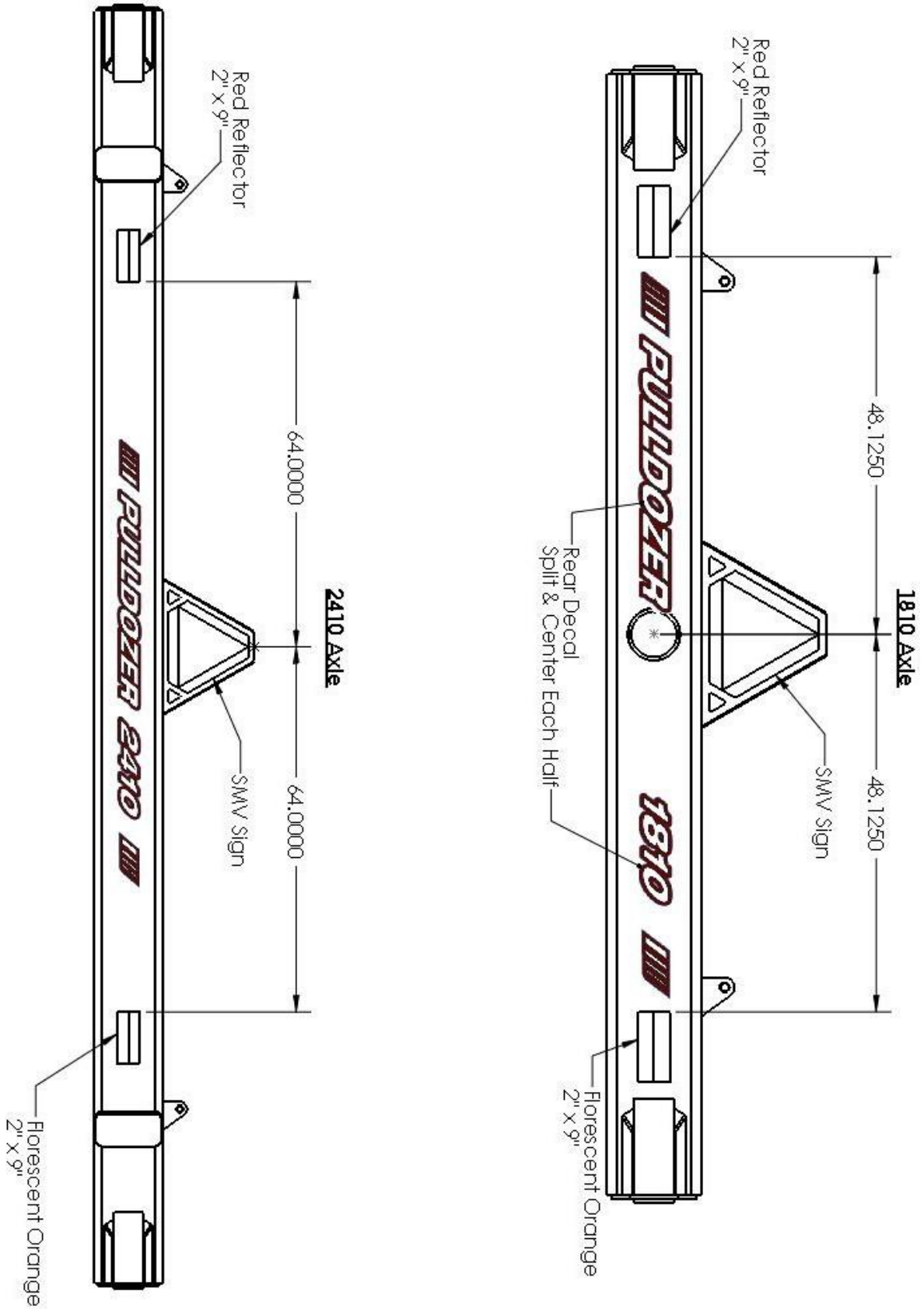

### 1810/2410 Light Bracket

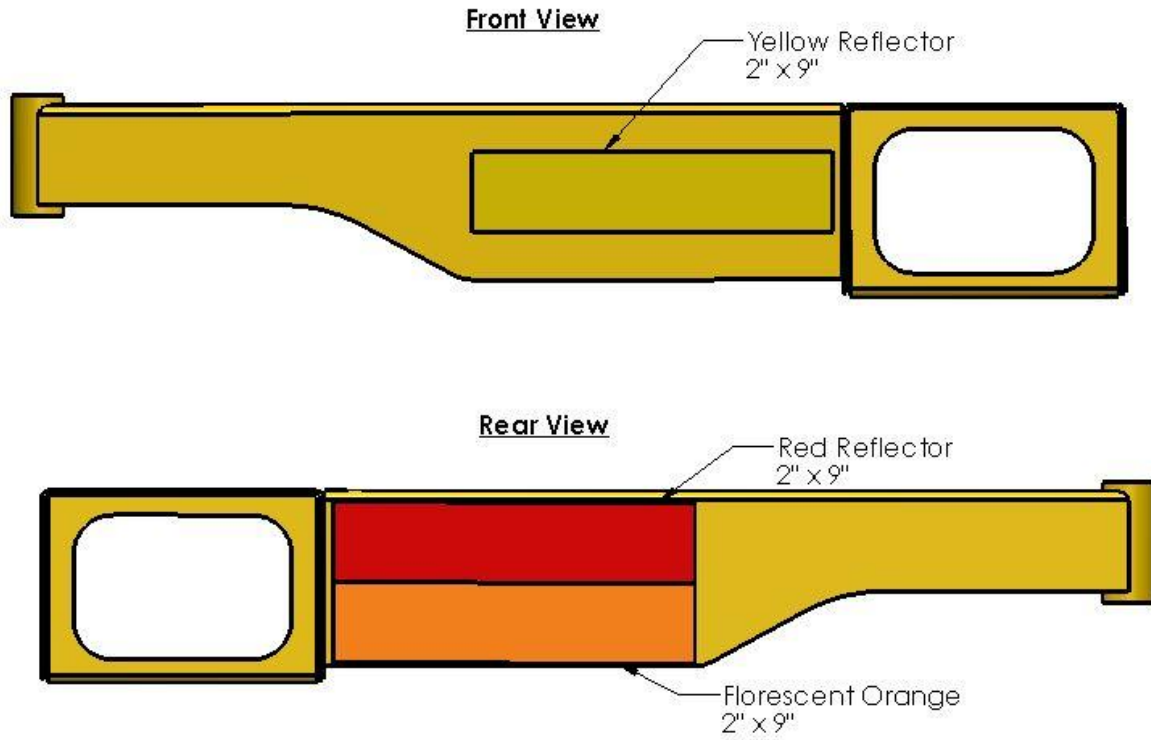

#### PULLDOZER ANGLE INDICATOR

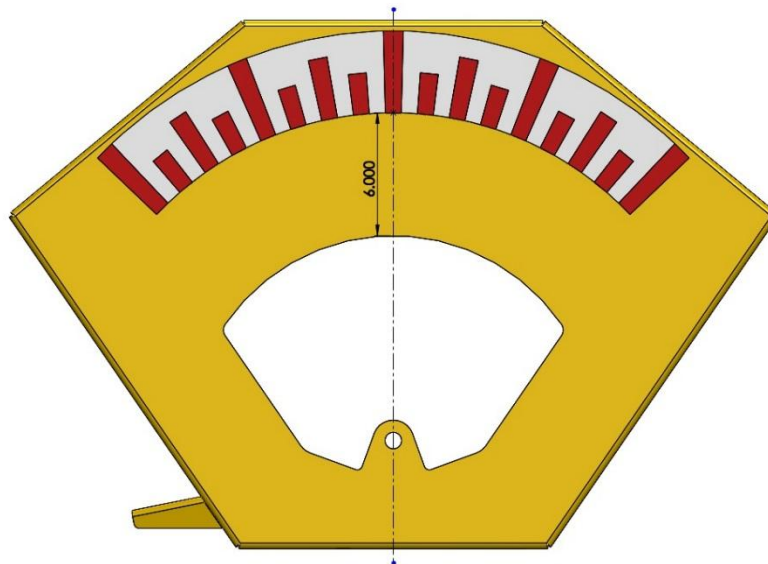

**PULLDOZER TRENCHER  
DEPTH INDICATOR**

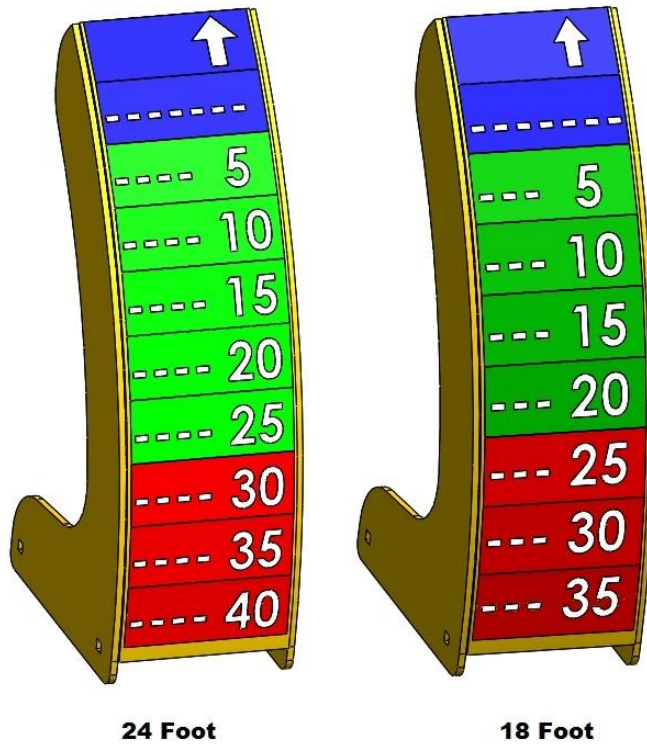

Pulldozer Hydraulic  
Hose Decal (33135)

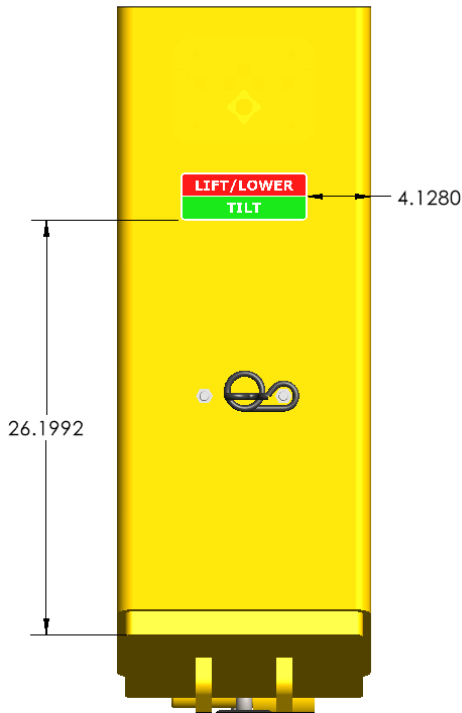

**- ASSEMBLY IS NOW COMPLETE -**



### FASTENER TORQUE CHARTS

DIAMETER & THREADS PER INCH	BOLT CLAMP LOADS Suggested Assembly Torque Values									
	USS/SAE GRADE 5					USS/SAE GRADE 8				
	TENSILE STRENGTH MIN. PSI	PROOF LOAD LB	CLAMP LOAD LB	TORQUE DRY FT LB	LUBRICATED FT LB	TENSILE STRENGTH MIN. PSI	PROOF LOAD LB	CLAMP LOAD LB	TORQUE DRY FT LB	LUBRICATED FT LB
1/4-20 28	120,000	2,700	2,020	8	6.3	150,000	3,800	2,850	12	9
	120,000	3,100	2,320	10	7.2	150,000	4,350	3,250	14	10
5/16-18 24	120,000	4,450	3,340	17	13	150,000	6,300	4,700	24	18
	120,000	4,900	3,700	19	14	150,000	6,950	5,200	27	20
3/8-16 24	120,000	6,600	4,950	30	23	150,000	9,300	6,980	45	35
	120,000	7,450	5,600	35	25	150,000	10,500	7,900	50	35
7/16-14 20	120,000	9,050	6,780	50	35	150,000	12,800	9,550	70	50
	120,000	10,100	7,570	55	40	150,000	14,200	10,650	80	60
1/2-13 20	120,000	12,100	9,050	75	55	150,000	17,000	12,750	110	80
	120,000	13,600	10,200	85	65	150,000	19,200	14,400	120	90
9/16-12 18	120,000	15,500	11,600	110	80	150,000	21,800	16,350	150	110
	120,000	17,300	12,950	120	90	150,000	24,400	18,250	170	130
5/8-11 18	120,000	19,200	14,400	150	110	150,000	27,100	20,350	210	160
	120,000	21,800	16,350	170	130	150,000	30,700	23,000	240	180
3/4-10 16	120,000	28,400	21,300	260	200	150,000	40,100	30,100	380	280
	120,000	31,700	23,780	300	220	150,000	44,800	33,500	420	310
7/8-9 14	120,000	39,300	29,450	430	320	150,000	55,400	41,600	600	450
	120,000	43,300	32,450	470	350	150,000	61,100	45,800	670	500
1-8 14	120,000	51,500	38,600	640	480	150,000	72,700	54,500	910	680
	120,000	57,700	43,300	720	540	150,000	81,500	61,100	1,020	760

When using anti-seize, reduce the lubed chart reading by 20% to properly torque. Always lubricate and use lubed torque values.

Torques for Grades 5 and 8 were calculated based on the following relationship:

$$T = R D P$$

- Where: T = Torque (ft lb)
- D = Nominal Diameter (in)
- P = Clamp Load (lb)
- R = Tightening Coefficient

The value of R is assumed to be equal to .20 for dry, unplated conditions and equal to .15 for lubricated, including plated, conditions. Actual values of R can vary between .05 and .35 for commonly encountered conditions.

**NOTES:**

The above recommended assembly torques are offered as a guide only. Torque specifications, especially for critical joints, should be determined under actual assembly conditions due to the many variables involved which are difficult to predict and do affect the torque-tension relationship.

The above recommended clamp loads are based on 75% of the minimum specified proof loads for each grade and size.

STRENGTH GRADE	APPLICABLE SIZES	PROOF LOAD STRESS (PSI)	YIELD STRENGTH MIN. STRESS (PSI)	TENSILE STRESS MIN. (PSI)
SAE Gr. 5	1/4 to 1" diameter over 1" diameter to 1-1/2 diameter	85,000	92,000	120,000
		74,000	81,000	105,000
SAE Gr. 8	1/4 to 1" diameter	120,000	130,000	150,000

Pounds to Inch Pound Conversion  
 lb x 12 = inch lb  
 Example: 9 lb x 12 = 108 inch lb

FRACTIONAL MEASUREMENT		
BOLT DIAMETER	CAP SCREW WRENCH SIZE	NUT WRENCH SIZE
1/4	7/16	7/16
5/16	1/2	1/2
3/8	9/16	9/16
7/16	5/8	11/16
1/2	3/4	3/4
9/16	13/16	7/8
5/8	15/16	15/16
3/4	1-1/8	1-1/8
7/8	1-5/16	1-5/16
1"	1-1/2	1-1/2
1-1/8	1-11/16	1-11/16
1-1/4	1-7/8	1-7/8
1-3/8	2-1/16	2-1/16
1-1/2	2-1/4	2-1/4
1-3/4	2-5/8	2-5/8
2"	3"	3"
2-1/4	3-3/8	3-3/8
2-1/2	3-3/4	3-3/4
2-3/4	4-1/8	4-1/8
3"	4-1/2	4-1/2

Imperial has made a concerted effort to provide accurate information in its catalog and on its website, however Imperial assumes no responsibility for the accuracy of the information. All information published by Imperial in its catalogs, marketing literature, and on its website is provided "as is" without warranty, expressed or implied. Imperial and its vendors disclaim all warranties, expressed or implied including, without limitation, warranties of merchantability and fitness for a particular purpose.



### FASTENER TORQUE CHARTS

GUIDE FOR PREVAILING-TORQUE LOCK NUT ASSEMBLY TORQUES (CAD AND WAX, GRADE B, C, AND GRADE G FLANGE NUTS) LOCK NUT STANDARDS FROM IFI-100 REQUIREMENTS

Torque-Tension Requirements

SIZE Threads Per Inch	GRADE B			GRADE C			GRADE G		
	CLAMP LOAD (Lb)	ASSEMBLY TORQUE MAX.	MIN.	CLAMP LOAD (Lb)	ASSEMBLY TORQUE MAX.	MIN.	CLAMP LOAD (Lb)	ASSEMBLY TORQUE MAX.	MIN.
1/4-20	2,000	85**	60**	2,850	125**	85**	2,850	150**	100**
1/4-28	2,300	90**	65**	3,250	125**	85**	3,250	160**	105**
5/16-18	3,350	150**	110**	4,700	190**	130**	4,700	240**	155**
5/16-24	3,700	160**	120**	5,200	200**	140**	5,200	230**	155**
3/8-16	4,950	20	14.5	6,950	28	20	6,950	32	21
3/8-24	5,600	22	16	7,900	29	21	7,900	33	22
7/16-14	6,800	32	23	9,600	43	31	9,600	51	34
7/16-20	7,550	34	24	10,700	43	31	10,700	60	40
1/2-13	9,050	50	37	12,800	62.5	45	12,800	85	55
1/2-20	10,200	52.5	37.5	14,440	70	50	14,440	89	59
9/16-12	11,600	70	50	16,400	95	70	16,400	120	80
9/16-18	13,000	77.5	57.5	18,300	95	70	18,300	132	88
5/8-11	14,500	95	70	20,300	122.5	90	20,300	143	95
5/8-18	16,300	97.5	72.5	23,000	125	90	23,000	175	115
3/4-10	21,300	165	125	30,100	210	155	30,100	240	160
3/4-16	23,800	165	120	33,600	210	155	33,600	270	170
7/8-9	29,500	250	185	41,600	312.5	225	41,600	360	260
7/8-14	32,400	270	200	45,800	312.5	225	45,800	402	247
1-8	38,700	375	275	54,600	462.5	360	54,600	530	410
1-12	42,300	395	290	59,750	490	360	59,750	—	—
1-14	43,000	400	300	61,100	500	362.5	61,100	645	398
1-1/8-7	42,100	404	294	69,000	585	454	69,000	—	—
1-1/8-12	47,500	437	327	76,800	622	453	76,800	—	—
1-1/4-7	53,500	513	375	87,000	736	573	87,000	—	—
1-1/4-12	59,700	549	412	96,600	782	570	96,600	—	—
1-3/8-6	63,800	612	445	104,000	880	685	104,000	—	—
1-3/8-12	72,900	670	503	118,000	955	696	118,000	—	—
1-1/2-6	77,600	745	545	127,000	1,075	837	127,000	—	—
1-1/2-12	87,700	807	605	142,000	1,150	837	142,000	—	—

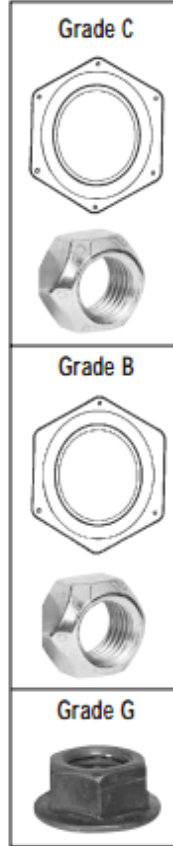

- Clamp loads for the Grade B lock nuts equal 75% of the bolt proof loads specified for SAE J-429 Grade 5, and ASTM A-449 bolts.
- Clamp loads for Grade C lock nuts equal 75% of the bolt proof loads specified for SAE J-429 Grade 8, and ASTM A-354 Grade BD bolts.
- IFI-100 does not govern lock nuts above 1". The values shown in the chart are to be used as a mid-range guideline.
- \*\* Torque values for 1/4" and 5/16" sizes are in inch lb. All other torque values are in foot lb.

#### METRIC TORQUE CHART FOR HEX HEAD CAP SCREWS

SIZE	CLASS	NEWTON METERS		FOOT POUNDS (APPROX.)		CLASS
		ZINC PLATED	UNPLATED	ZINC PLATED	UNPLATED	
M4 x .70 Pitch	8.8	3.1	2.2	2.30	1.65	8.8
M5 x .80 Pitch	8.8	6.1	5.5	4.58	4.13	
M6 x 1.00 Pitch	8.8	10.4	9.5	7.80	7.13	
M7 x 1.00 Pitch	8.8	17.0	15.5	12.75	11.63	
M8 x 1.25 Pitch	8.8	25.0	23.0	18.75	17.25	
M8 x 1.00 Pitch	8.8	27.0	24.5	20.25	18.38	
M10 x 1.50 Pitch	8.8	51.0	46.0	38.25	34.50	
M10 x 1.00 Pitch	8.8	57.0	52.0	42.75	39.00	
M10 x 1.25 Pitch	8.8	54.0	49.0	40.50	36.75	
M12 x 1.75 Pitch	8.8	87.0	79.0	65.25	59.25	
M12 x 1.25 Pitch	8.8	96.0	87.0	72.00	65.25	
M12 x 1.50 Pitch	8.8	92.0	83.0	69.00	62.25	
M14 x 2.00 Pitch	8.8	140.0	125.0	105.00	93.75	
M14 x 1.50 Pitch	8.8	150.0	135.0	112.50	101.25	
M16 x 2.00 Pitch	8.8	215.0	195.0	161.25	146.25	
M18 x 2.50 Pitch	8.8	300.0	280.0	225.00	210.00	
M20 x 2.50 Pitch	8.8	430.0	390.0	322.50	292.50	
M22 x 2.50 Pitch	8.8	580.0	530.0	435.00	397.50	
M24 x 3.00 Pitch	8.8	740.0	670.0	555.00	502.50	
M6 x 1.00 Pitch	10.9	15.5	14.0	11.63	10.50	10.9
M8 x 1.25 Pitch	10.9	37.0	34.0	27.75	25.50	
M10 x 1.50 Pitch	10.9	75.0	68.0	56.25	51.00	
M12 x 1.75 Pitch	10.9	160.0	117.0	97.50	87.75	
M14 x 2.00 Pitch	10.9	205.0	185.0	153.75	138.75	
M16 x 2.00 Pitch	10.9	310.0	280.0	232.50	210.00	

#### TORQUE CHART FOR STAINLESS STEEL CAP SCREWS

SIZE	316 INCH-LB	18/8 INCH-LB
6-32	10.1	9.6
6-40	12.7	12.1
8-32	20.7	19.8
8-36	23.0	22.0
10-24	23.8	22.8
10-32	33.1	31.7
1/4-20	78.8	75.2
1/4-28	99.0	94.0
5/16-18	138.0	132.0
5/16-24	147.0	142.0
3/8-16	247.0	236.0
3/8-24	271.0	259.0
7/16-14	393.0	376.0
7/16-20	418.0	400.0
1/2-13	542.0	517.0
1/2-20	565.0	541.0
9/16-12	713.0	682.0
9/16-18	787.0	752.0
5/8-11	1,160.0	1,110.0
5/8-18	1,301.0	1,244.0
3/4-10	1,582.0	1,530.0
3/4-16	1,558.0	1,490.0
7/8-9	2,430.0	2,328.0
7/8-14	2,420.0	2,318.0
1"-8	3,595.0	3,440.0
1"-14	3,250.0	3,110.0

PHONE: 1-800-558-2808

FAX: 1-800-553-8769

WEB: www.imperialsupplies.com



